

1902 - Serving Our Community for over 115 Years - 2020
WEST BAY SANITARY DISTRICT
AGENDA OF BUSINESS
REGULAR MEETING OF THE DISTRICT BOARD
WEDNESDAY, FEBRUARY 26, 2020 AT 7:00 P.M.
RONALD W. SHEPHERD ADMINISTRATION BUILDING,
500 LAUREL STREET, MENLO PARK, CALIFORNIA 94025

Board Members

Fran Dehn, President
David Walker, Secretary
Roy Thiele-Sardiña, Treasurer
Edward P. Moritz, Member
George Otte, Member

District Manager

Phil Scott

District Legal Counsel

Anthony Condotti, Esq.

AGENDA OF BUSINESS

NOTE: The Board may take action on any agenda item unless specifically designated a “discussion” item or a “report.”

1. Call to Order and Roll Call
2. Communications from the Public
3. District Manager’s Report Pg. 3-1
4. Consent Calendar
Matters listed under this item are considered routine and will be enacted by one motion. The motion, seconds, and vote are applicable to any included resolutions and recorded accordingly. There will be no separate discussion of these items unless specifically requested by a member of the Board.
 - A. Approval of Minutes for Regular meeting February 12, 2020 Pg. 4A-1
 - B. Approval of the Withdrawal Order Authorizing Payment of Certain Bills and Salaries and Consideration of Other Financial Matters for February 26, 2020 Pg. 4B-1
 - C. Bank of the West Monthly Investment Portfolio Statements Pg. 4C-1
 - D. Consideration of a Resolution of Intention to Annex Certain Territory (20 Navajo PI) to the West Bay Sanitary District On-Site Wastewater Disposal Zone and to Establish the Date and Time of Public Hearing Pg. 4D-1
5. Discussion and Direction on Recycled Water Projects - Sharon Heights & Bayfront, Including Project Status Pg. 5-1
6. Report & Discussion on South Bayside Waste Management Authority (SBWMA) Pg. 6-1
7. Report & Discussion on Silicon Valley Clean Water (SVCW), Discussion on SVCW CIP Program and Financing Pg. 7-1

8. Closed Session:
 - A. CONFERENCE WITH LEGAL COUNSEL – EXISTING LITIGATION
(Cal. Govt. Code §54956.9(d))
Name of Case: *1740 Oak Avenue, LP v. West Bay Sanitary District, et al.* – SM CSC
Case No. 18CIV02183
 - B. CONFERENCE WITH LABOR NEGOTIATORS
(Pursuant to Cal. Govt. Code §54957.6) Agency designated representatives: Legal Counsel
Unrepresented Employee: District Manager
 - C. PUBLIC EMPLOYMENT
(Pursuant to Cal. Govt. Code §54957)
Title: District Manager Recruitment
 - D. PUBLIC EMPLOYMENT
(Cal. Govt. Code §54957)
Title: Finance Manager
 - E. CONFERENCE WITH LEGAL COUNSEL—EXISTING LITIGATION
(Subdivision (a) of Section 54956.9)
Chan, Moreno, Vestnys, Pebbles v. WBSD – San Mateo County Court Case No. 19CIV07567
9. Comments or Reports from Members of the District Board and Consider Items to be Placed on Future Agenda
10. Adjournment

The West Bay Sanitary District does not discriminate against persons with disabilities. Upon request, the agenda and agenda packet can be provided in a format to accommodate special needs. If you require a copy of the agenda or related materials in an alternative format to accommodate a disability, or if you wish to attend this public meeting and will require special assistance or other special equipment, please call the District at (650) 321-0384 at least five days in advance and we will make every reasonable attempt to provide such an accommodation.



WEST BAY SANITARY DISTRICT AGENDA ITEM 3

To: *Board of Directors*

From: *Phil Scott, District Manager*

Subject: *District Manager's Report*

1) **CIP Project:**

- a. **Belle Haven III:** CIP construction began July 23. 99% complete.
- b. **Cleaning/TVing Large Diameter lines:** With Board approval Staff has obtained new heavy duty cleaning nozzle and large tractor for camera for televising large lines. The tractor, called the MudMaster, has now arrived and Staff will begin cleaning and televising lines full time once the MudMaster is connected and fully operational.

2) **Affiliate Agency/Association News:**

- a. **C/CAG:** DM gave a presentation on the Recycled Water Project – Sharon Heights to the City and County Association of Governments of San Mateo County on February 19.
- b. **WaterReuse– San Francisco Conference:** DM was asked to join West Yost Associates to present a paper on the Onsite Reuse Treatment Plant discharge permit process on March 16, 2020.
- c. **CWEA Annual Conference:** DM & W&C will present on Recycled Water Treatment Facility and the use of Time Lapse photography and Drone Video for construction documentation and messaging on April 3.
- d. **CMPK:** Met with City staff regarding Bayfront Recycled Water project and briefly discussed the Onetta Harris Community Center in regards to sewer main location and possibly vacating an easement. Also discussed was the Metal Building Planning review. One day later, emails began flowing from the City regarding the planning review.
- e. **San Mateo County Flood and Sea Level Rise Resiliency District:** On September 1, 2019, after the 30-day public review period, the Governor signed into law Assembly Bill 825, the Governor signed into law Assembly Bill 825 (“AB 825”), which renamed the District, expanded its scope to address and protect against the impacts of sea level rise, and, commencing January 1, 2020, changed the governance of the District from the San Mateo County Board of Supervisors sitting as the governing board to an independent board of directors. Therefore, the District has assumed the role of Lead Agency and authority to adopt the IS/MND.

3) **Upcoming Events:**

- a. **Board meetings:** Next meeting March 11, 2020.
- b. **Budget Workshop:** April 29, 2020 at 5 pm.

4) **Misc./Action Items from Previous Meeting:**

- a. **SSOs:** Zero SSO for January. 2020 Total = 0. 8 months in a row w/o SSO.
- b. **LAH:** 1 SSO for February. 39 gallons in total. **1st SSO in over 12 months.**

Report to the District Board for the Regular Meeting of February 26, 2020

Additional information or topics may be introduced by the DM verbally during the Board meeting.

THIS PAGE LEFT INTENTIONALLY BLANK



1902 - Serving Our Community for over 110 Years - 2020

**WEST BAY SANITARY DISTRICT
MINUTES OF THE REGULAR MEETING OF THE DISTRICT BOARD
WEDNESDAY, FEBRUARY 12, 2020 AT 7:00 P.M.**

1. Call to Order

President Dehn called the meeting to order at 7:04 PM

Roll Call

BOARD MEMBERS PRESENT: Dehn, Otte, , Walker, Moritz

BOARD MEMBERS ABSENT: Thiele-Sardiña

STAFF MEMBERS PRESENT: Scott, Condotti, FM Sturman

Others Present: HF&H - John Farnkopf and Gabe Sasser

2. Communications from the Public: Tom Carey was present for Item 8F but had no comments.

8. Consent Calendar

Motion to Approve by: Walker 2nd by: Moritz Vote: AYE: 4 NAY: 0 Abstain: 0

CONSIDERATION OF ITEM(S) REMOVED FROM THE CONSENT CALENDAR

Comments: None.

- A. Approval of Minutes for Regular meeting January 22, 2020
- B. Approval of the Withdrawal Order Authorizing Payment of Certain Bills and Salaries and Consideration of Other Financial Matters for February 12, 2020
- C. WBSD Operations and Maintenance Report – January 2020
- D. Town of Los Altos Hills Operations and Maintenance Report for Work Performed by WBSD – January 2020
- E. Consideration of Accepting the Work Pursuant to Class 3 Sewer Permit No. 1101 for the Access Path and Grading Around an Existing Manhole
- F. Consideration of Accepting Sewer Facilities Constructed Pursuant to Class 3 Sewer Permit No. 1075 for the Construction of the Gravity Main Extension for 105 & 109 Santa Maria, Portola Valley, California

3. **Public Hearing: Consideration to Approve a General Regulation Amending the Code of General Regulations for Section 406. Backflow Prevention Devices and Section 901. Sewer Connection Charges (03) Charges by Type of Connection – Accessory Dwelling Unit**

Motion to Open by: Moritz 2nd by: Otte Vote: AYE: 4 NAY: 0 Abstain: 0

Comments: None.

Motion to Close by: Moritz 2nd by: Otte Vote: AYE: 4 NAY: 0 Abstain: 0

4. **Consideration to Approve a General Regulation Amending the Code of General Regulations for Section 406. Backflow Prevention Devices and Section 901. Sewer Connection Charges (03) Charges by Type of Connection – Accessory Dwelling Unit**

Motion to Approve by: Moritz 2nd by: Otte Vote: AYE: 4 NAY: 0 Abstain: 0

Comments: DM Scott outlined the need for a code change for these two items.

5. **Consideration of the Establishment of a Public Hearing Date for Proposed Increase in Sewer Service Charges as Required by Proposition 218, Adopt the Updated Sewer Rate Study and Provide Staff Direction Regarding the Sewer Service Charge Rate Adjustment and the Mailing of the Proposition 218 Notice for a Public Hearing**

Motion to Approve by: Moritz 2nd by: Otte Vote: AYE: 4 NAY: 0 Abstain:

Comments: John Farnkopf of HF&H presented the draft rate study which included a 5-year revenue requirement projection. The revised rate model predicted rate increases for residential in the order of 4.0% in 2020-21. Approximately 79 homes in the Portola Valley area (located within the On-Site Wastewater Disposal Zone) pay higher charges for the maintenance of the STEP or Grinder Sewer Collection Systems that they require. The District currently charges an additional \$320 annually to maintain these collection systems. However, the current cost of service per account exceeds the current charge by \$599. To realign charges with the cost of service, charges for the maintenance of the STEP/Grinder Sewer Collection Systems are proposed to increase annually over the next five fiscal years. For fiscal year 2020/21, the proposed STEP/Grinder Sewer Collection System charge is \$470, an increase of \$150. A 4% increase in residential sewer service charges will result in annual sewer service rates for a single family home increasing from \$1,177 to \$1,224 per year. For homes (approximately 79 homes) within the OWDZ (Onsite Wastewater Disposal Zone), primarily in Portola Valley, the anticipated sewer service charge will increase from \$1,497 to \$1,694 per household. Overall, this equates to an increase in revenues of approximately \$1.2M per year.

6. **Consider to Approve Second Quarter Internal Financial Statements & Analysis of Financial Position as of Quarter End December 31, 2019**

Motion to Approve by: Moritz 2nd by: Walker Vote: AYE: 4 NAY: 0 Abstain: 0

Comments: None.

7. District Manager's Report

1) Comments: CIP Project:

- a. **Belle Haven III**: CIP construction began July 23. 99% complete.
- b. **Cleaning/TVing Large Diameter lines**: Staff has ordered new heavy duty cleaning nozzle and large tractor for camera for televising large lines. Crews have begun cleaning and tving some of the smaller of the large diameter lines but will be limited until the new equipment arrives. Staff will begin cleaning and televising lines full time once the tractor equipment arrives expected to arrive in about 2 weeks.

2) **Affiliate Agency/Association News**:

- a. **CWEA P3S Conference**: DM and W&C presented on time delay discharge at P3S conference January 28, 2020 in Long Beach.
- b. **WaterReuse– San Francisco Conference**: DM was asked to join West Yost Associates to present a paper on the Onsite Reuse Treatment Plant discharge permit process on March 16, 2020.
- c. **CWEA Annual Conference**: DM & W&C will present on Recycled Water Treatment Facility and the use of Time Lapse photography and Drone Video for construction documentation and messaging on April 3.
- d. **CMPK**: Met with City staff regarding Onetta Harris Community Center to discuss sewer main location and possibly vacating an easement. Also discussed Metal Building Planning review.

3) **Upcoming Events**:

- a. **Board meetings**: Next meeting February 26, 2020.
- b. **Sewer Service Charges Rate Study**: Rate study public hearing anticipated April 22, 2020.

4) **Misc./Action Items from Previous Meeting**:

- a. **SSOs**: Zero SSO for January. 2020 Total = 0. 8 months in a row w/o SSO.
- b. **LAH**: 1 SSO for February. 39 gallons in total. **1st SSO in over 12 months.**
- c. **Investment Reports**: DM would like to submit investments reports for Board approval quarterly instead of monthly. Monthly reports will still be provide for Board information purposes.
- d. **1540 El Camino Real Project**: An agreement has been made with the District.

8. Discussion and Direction on Recycled Water Projects - Sharon Heights & Bayfront, Including Project Status

Comments: DM Scott reported the forcemain through the Caltrans right-of-way is nearly complete and the connection at treatment facility has been made. He met with the City of Menlo Park regarding the Facebook facility and will also meet next week to work on costs of Bayfront Recycled Water facility. He is continuing to work on needed easements for Bayfront project.

9. Report & Discussion on South Bayside Waste Management Authority (SBWMA)

Comments: President Dehn reported that the Board of Supervisors are considering banning all single use containers. The Organics to Energy equipment has been installed. A transition is underway at SBWMA from a fiscal year budget to a calendar year budget with the budget approval in May or June for a 6 month budget and then approval for a 12-month calendar year budget.

11. Report, Discussion & Direction on Silicon Valley Clean Water (SVCW) and Discussion on SVCW CIP Program and Financing

Comments: Director Otte reported that there are two new Commission members. He recently was able to tour the tunnel part of the CIP.

12. Closed Session

- A. CONFERENCE WITH LEGAL COUNSEL – EXISTING LITIGATION
(Cal. Govt. Code §54956.9(d))
Name of Case: *1740 Oak Avenue, LP v. West Bay Sanitary District, et al.* – SM CSC
Case No. 18CIV02183

- B. CONFERENCE WITH LABOR NEGOTIATORS
(Pursuant to Cal. Govt. Code §54957.6) Agency designated representatives: Legal Counsel
Unrepresented Employee: District Manager

- C. PUBLIC EMPLOYMENT
(Pursuant to Cal. Govt. Code §54957)
Title: District Manager Recruitment

- D. CONFERENCE WITH LEGAL COUNSEL—EXISTING LITIGATION
(Subdivision (a) of Section 54956.9)
Chan, Moreno, Vestnys, Pebbles v. WBSD – San Mateo County Court Case No. 19CIV07567

Entered closed session at 9:00 p.m. Left closed session at 9:37 p.m.

Reportable action: None.

13. Comments or Reports from Members of the District Board and Consider Items to be Placed on Future Agenda

Comments: Director Mortiz has requested an April report on forecasted capital expenditures as well as a review of monthly or quarterly over-time for the last couple years.

14. Adjournment Time: The meeting was adjourned at 9:42 PM

WEST BAY SANITARY DISTRICT
WITHDRAWAL ORDER
As of February 17, 2020

CHECK	TO WHOM PAYABLE	PURPOSE	AMOUNT
66198	MATHESON TRI-GAS, INC.	Operating Supplies - Coll	50.71
66199	AMERICAN MESSAGING	Utilities - A&G	64.24
66200	BAY AREA PAVING CO. INC.	Operating Supplies - Coll	8,800.00
66201	CALIFORNIA WATER SERVICE	Utilities - Coll	18.39
66202	CINTAS CORP	Contract Services - Coll	885.16
66203	CUSI	Repairs & Maintenance - Coll	13,750.00
66204	DEWEY PEST CONTROL	Contract Services - Coll	8,367.00
66205	ALLIANT INSURANCE SERVICES INC	Insurance - A&G	168.00
66206	NAVIA BENEFIT SOLUTIONS	Employee Benefits - A&G	1,025.00
66207	HOME DEPOT CREDIT SERVICES	Operating Supplies - Coll	1,476.16
66208	IEDA	Professional Services - A&G	760.00
66209	JANI-KING OF CA, INC - SFR/OAK	Contract Services - A&G	743.31
66210	LOG ME IN	Repairs & Maintenance - Coll	65.72
66211	MENLO PARK CHAMBER OF COMMERCE	Memberships - A&G	475.00
66212	CITY OF MENLO PARK - Repair	Repairs & Maintenance - Coll	529.65
66213	CITY OF MENLO PARK-Fuel	Gasoline, Oil & Fuel - Coll	5,053.75
66214	PACIFIC GAS & ELECTRIC	Utilities - A&G	4,112.41
66215	ROBERTS & BRUNE CO	Operating Supplies - Coll	736.95
66216	SEEKZEN SYSTEMS	Professional Services - Coll	475.00
66217	SHAPE INCORPORATED	Pump Replacement	30,147.54
66218	SHARP BUSINESS SYSTEMS	Rents & Leases - Coll	1,036.78
66219	SHARP ELECTRONICS CORPORATION	Rents & Leases - Coll	69.83
66220	TELETRAC NAVMAN US LTD.	Contract Services - Coll	492.43
66221	VISION COMMUNICATIONS CO.	Rents & Leases - A&G	667.00
66222	SAN MATEO COUNTY CLERK	Other Operating Expenses - A&G	26.00
66223	PHIL SCOTT	Training, Meetings & Travel - A&G	191.15
66224	PHIL SCOTT	Travel, Meetings, & Travel - A&G	173.29
66225	PRECISE PRINTING AND MAILING	Printing and Publications - A&G	10,003.84
66226	SDU	Wage Garnishment	508.62
66227	FRANCHISE TAX BOARD	Wage Garnishment	250.00
66228	NAVIA BENEFIT SOLUTIONS	Employee Benefits	929.24
66229	BANKCARD CENTER	BoW Credit Card - Todd	2,436.61
66230	BANKCARD CENTER	BoW Credit Card - Phil	48.84
66231	BANKCARD CENTER	BoW Credit Card - Sergio	953.77
66232	GEORGE / KAREN MCCOWN	Other Operating Expense - A&G	2,996.72
66233	ATCHISON, BARISONE & CONDOTTI	Professional Services - A&G	7,518.29
66234	BAYSIDE EQUIPMENT COMPANY	Standby Generator	79,608.59
66235	CALPERS LONG-TERM CARE PROGRAM	LTC Withholding	35.36
66236	DU-ALL SAFETY, LLC	Professional Services - Coll	1,620.00
66237	THE ALMANAC	Printing & Publications - A&G	2,369.20
66238	FREYER & LAURETA	Professional Services & CIP: Levee Design & Construction Observation	39,041.92
66239	HACH COMPANY	Operating Supplies - Coll	854.36
66240	KONE INC.	Contract Services - A&G	259.34
66241	PREFERRED ALLIANCE	Professional Services - A&G	361.98
66242	SNAP ON INDUSTRIAL C/O	Operating Supplies - Coll	750.72
66243	WOODARD & CURRAN	Professional Services - A&G	4,177.62
66244	RUPERT SANDOVAL	Training, Meetings & Travel - Coll	116.55
66245	ANDERSON PACIFIC	CIP: SHGCC Recycled Water Project	573,396.29
		TOTAL CHECKS	808,598.33

WIRES

<u>TRANSFER DATE</u>	<u>PURPOSE</u>	
2/5/2020	PrimePay Fees	\$940.10
2/6/2020	Transfer to Money Market for Equipment Replacement Reserve	\$270,000.00
2/7/2020	CalPERS Medical	\$48,818.99
2/14/2020	Employee Payroll - Pay Period 01/31-02/14	\$101,380.77
2/14/2020	ICMA	\$11,181.80
2/14/2020	Federal Payroll Taxes	\$21,100.09
2/14/2020	State Payroll Taxes	\$6,931.32
	WIRE TRANSFERS FROM BoW CHECKING	<u>460,353.07</u>
2/13/2020	Recology Remittance	8,477.43
2/14/2020	SRF Reimbursement #17	\$400,943.00
	WIRE TRANSFERS TO BoW CHECKING	<u>8,477.43</u>

President

Secretary

**WITHDRAWAL ORDER
SUPPLEMENTAL PURCHASE REGISTER
02/17/2020**

OPERATING SUPPLIES & OFFICE EXPENSE

<u>CHECK</u>	<u>AMOUNT</u>	<u>VENDOR</u>	<u>DESCRIPTION</u>
66200	8,800.00	BAY AREA PAVING CO. INC.	Road Paving at N. Lemon & Santa Margarita
66217	30,147.54	SHAPE INCORPORATED	Pump Replacement at Willow & University Pump Stations
66225	10,003.84	PRECISE PRINTING AND MAILING	Annual Printing & Mailing of Easement Reminder Letters
66229	2,436.61	BANKCARD CENTER	Todd: FasTrack, Training, Meeting Expense
66230	48.84	BANKCARD CENTER	Phil: Commuter Parking
66231	953.77	BANKCARD CENTER	Sergio: CWEA Banquet Expense
66234	79,608.59	BAYSIDE EQUIPMENT COMPANY	Standby Generator

MISCELLANEOUS

<u>CHECK</u>	<u>AMOUNT</u>	<u>VENDOR</u>	<u>DESCRIPTION</u>
66203	13,750.00	CUSI	Annual Maintenance & Technical Support
66204	8,367.00	DEWEY PEST CONTROL	Pest & Rodent Control for Mainlines
66223	191.15	PHIL SCOTT	Reimbursement: CWEA P3S Conference - Presentation
66224	173.29	PHIL SCOTT	Reimbursement: CWEA TriState Conference - Board Meeting
66232	2,996.72	GEORGE / KAREN MCCOWN	Claim Payment - Parking Lot Incident
66237	2,369.20	THE ALMANAC	Annual Newsletter
66238	39,041.92	FREYER & LAURETA	Prof. Services - Levee Design, SHGCC Construction Observation, & Misc. Engineering
66243	4,177.62	WOODARD & CURRAN	As Needed Discharge Support
66244	116.55	RUPERT SANDOVAL	Reimbursement: Office Water Program Course
66245	573,396.29	ANDERSON PACIFIC	SHGCC Recycled Water Project

WEST BAY SANITARY DISTRICT

SUMMARY OF FY2019-20 PAYMENTS
(Through Withdrawal Order
01/14/2020 to 02/03/2020)

	TOTAL BY VENDOR - YTD 7/1/2019- 2/17/2020	WITHDRAWAL PERIOD 2/17/2020
REGULAR PAYABLES		
3T Equipment Company	28,368.28	-
A-A Lock & Alarm	1,444.70	-
AAA Rentals	11,819.27	-
A & B Trailer Hitch Inc.	13.06	-
Ace Fire Equipment & Service	972.11	-
Action Towing	487.50	-
Advanced Laser	2,843.89	-
Airgas USA, LLC	345.62	-
Alliant Insurance Services Inc	15,396.00	168.00
The Almanac	12,137.20	2,369.20
Alpha Analytical Laboratories	2,375.00	-
American Messaging	515.16	64.24
American Textile & Supply	171.48	-
American Water Services	228.84	-
Anderson Pacific	6,338,557.81	573,396.29
Aqua Natural Solutions	1,384.65	-
Aquality Water Management Inc.	8,865.86	-
AT&T	7,740.03	-
Atchison, Barisone & Condotti	40,424.77	7,518.29
Avery Associates, Inc.	8,900.00	-
Aztec Consultants	11,827.50	-
Baggengineers	1,660.00	-
Bankcard Center	33,910.85	3,439.22
Bay Alarm	8,413.84	-
Bay Area Air Quality Mgmt Dist	21,573.00	-
Bay Area Paving Co. Inc.	22,129.00	8,800.00
Bay Reprographic, Inc.	106.35	-
Bayside Equipment Company	116,663.89	79,608.59
Annette Bergeron	704.00	-
Jed M. Beyer	884.50	-
Beyond Components, Inc.	179.20	-
David D. Bohannon Org.	211,673.53	-
Bonny Doon Environmental	4,540.22	-
Buckles-Smith	251.60	-
CASA	13,370.00	-
CSDA	15,230.00	-
CUSI	13,750.00	13,750.00
CWEA-SCVS	1,180.00	-
CWEA	3,017.00	-
CWEA Membership	2,618.00	-
CSRMA C/O Alliant Insurance	298,653.00	-
Calif. Labor Law Poster Servic	152.00	-
California Concrete Pumping	774.00	-
California Water Service	10,137.10	18.39
CALPERS 1959 Survivor Billing	1,645.00	-
CALPERS - Unfunded Accrued Liability	334,727.00	-

WEST BAY SANITARY DISTRICT

SUMMARY OF FY2019-20 PAYMENTS
(Through Withdrawal Order
01/14/2020 to 02/03/2020)

	TOTAL BY VENDOR - YTD 7/1/2019- 2/17/2020	WITHDRAWAL PERIOD 2/17/2020
REGULAR PAYABLES		
CALPERS - Retirement	219,457.91	-
CALPERS - Health Premiums	321,344.20	48,818.99
Calpers Long-Term Care Program	451.65	35.36
Carrie Nevoli - Petty Cash	586.31	-
Cardiac Science Corp.	719.89	-
Center For Hearing Health Inc.	661.25	-
Chavan & Associates LLP	17,825.00	-
Chevron	67.00	-
Cintas Corp	27,352.47	885.16
Citibank	675.92	-
Comcast	2,225.33	-
Consolidated Parts, Inc	4,354.12	-
Costco Membership	60.00	-
CPS HR Consulting	18,484.86	-
Cropper Accountancy Corp.	2,700.00	-
Cues, Inc.	3,980.00	-
DMV	337.00	-
Dale Scott & Co., Inc.	4,000.00	-
Peggy Daniels	2,935.76	-
Das Manufacturing, Inc.	1,895.44	-
Davey Tree Expert Company	7,913.00	-
Dept. of Industrial Relations	675.00	-
Delta Diablo Sanitation District	8,567.61	-
Detection Instruments	327.79	-
Dewey Pest Control	8,531.00	8,367.00
Dolphin Graphics	4,329.50	-
Duke's Root Control, Inc	223,089.71	-
Du-All Safety, Llc	20,115.00	1,620.00
Elio D'Urzo	1,523.50	-
ENR	66.00	-
ESRI	7,200.00	-
East Bay Muni Utility District	2,425.00	-
Elite Parts LLC	1,233.65	-
Emergency Essentials	2,279.10	-
EnviroZyme	3,000.50	-
ErgoWorks	1,398.48	-
Express Safety, Inc.	773.32	-
Fast Response On-Site Testing	2,217.60	-
Federal Express	2,461.70	-
Fremont Urgent Care	1,692.00	-
Finishmaster Inc	837.56	-
Forestry Suppliers, Inc.	1,315.65	-
Formatop	1,387.48	-
Franchise Tax Board	4,250.00	250.00
Freyer & Laureta	254,017.01	39,041.92
Gary Pollack Construction	4,000.00	-
Goldstreet Design Agency, Inc.	2,751.50	-
Govconnection, Inc.	780.00	-
Governmentjobs.com dba NeoGov	6,633.00	-

WEST BAY SANITARY DISTRICT

SUMMARY OF FY2019-20 PAYMENTS
(Through Withdrawal Order
01/14/2020 to 02/03/2020)

	TOTAL BY VENDOR - YTD 7/1/2019- 2/17/2020	WITHDRAWAL PERIOD 2/17/2020
REGULAR PAYABLES		
Grainger	21,598.24	-
Granite Rock, Inc.	1,033.13	-
Hach Company	20,650.15	854.36
Hadronex, Inc.	34,919.44	-
Hansen Supply Company	4,710.58	-
Harben California	2,988.85	-
Harbor Ready-Mix	2,992.16	-
Harrington Industrial Plastics	192.59	-
HF&H Consultants, LLC	21,816.41	-
Hillyard/San Francisco	1,439.48	-
Home Depot Credit Services	9,312.11	1,476.16
Bob Hulsmann	1,274.26	-
IEDA	6,080.00	760.00
Innovyze, Inc	7,955.00	-
ISAC INC	6,581.50	-
J & B Corrosion Engineering	1,415.00	-
Jani-King of CA, Inc - SFR/OAK	5,829.51	743.31
Jensen Precast	2,454.32	-
KDS Communications	1,505.00	-
Kimball Midwest	4,666.61	-
Bill Kitajima	152.83	-
Kone Inc.	2,074.72	259.34
L & M Transmission	1,199.93	-
Lasky Trade Printing	141.38	-
Log Me In	2,132.98	65.72
Lucity, Inc.	20,741.42	-
Lyngso Garden Materials, Inc	356.78	-
Mail Finance	804.75	-
Mallory Co.	4,982.29	-
Matheson Tri-Gas, Inc.	390.73	50.71
Maxx Metals	138.00	-
George / Karen McCown	2,996.72	2,996.72
City of Menlo Park - Repair	33,999.92	529.65
City of Menlo Park-Fuel	41,979.29	5,053.75
City of Menlo Park - Water	5,971.80	-
City of Menlo Park - Permits	4,500.00	-
SDU	8,646.54	508.62
Medco Supply Company	396.05	-
Menlo Park Chamber of Commerce	475.00	475.00
Menlo Park Fire Protection	8,290.00	-
Menlo Park Hardware Co. #14016	1,096.21	-
Mid Peninsula Abstracts	810.00	-
Mission Clay Products LLC	3,486.92	-
Morse Hydraulics	673.62	-
Municipal Maintenance Equip.	1,667.98	-
National Auto Fleet	142,690.88	-
Navia Benefit Solutions	20,067.73	1,954.24
North Bay Pensions	1,500.00	-
Occasions, ETC.	75.35	-
Office of Water Programs	815.10	-

WEST BAY SANITARY DISTRICT

SUMMARY OF FY2019-20 PAYMENTS
(Through Withdrawal Order
01/14/2020 to 02/03/2020)

	TOTAL BY VENDOR - YTD 7/1/2019- 2/17/2020	WITHDRAWAL PERIOD 2/17/2020
REGULAR PAYABLES		
Office Team	8,072.00	-
Ogasawara Landscape Maint.	7,050.00	-
Omega Industrial Supply, Inc.	5,594.97	-
Pacific Gas & Electric	53,702.95	4,112.41
Palo Alto Staffing	1,309.60	-
Albert Patino	433.54	-
Peninsula Building Materials	2,941.01	-
Peninsula Property Group	1,602.75	-
Perotti and Carrade	750.00	-
Phil Scott	2,902.20	364.44
Pier 2 Marketing	1,950.00	-
PJ's Rebar Inc.	2,752.87	-
Ponton Industries, Inc.	18,515.35	-
Precise Printing and Mailing	14,386.07	10,003.84
Precision Engineering	312,189.19	-
Preferred Alliance	2,462.75	361.98
Principal Life Insurance Co.	39,170.77	-
Sergio Ramirez	5,458.31	-
R.A. Nosek Investigations	2,345.00	-
Ranger Pipelines	67,202.79	-
Readyrefresh By Nestle	2,374.83	-
Recology Peninsula Services	12,530.00	-
Red Wing Shoe Store	3,768.46	-
Redwood General Tire Co., Inc.	65.87	-
Reg Solutions	200.00	-
Rich Voss Trucking	2,405.00	-
Roberts & Brune Co	21,675.84	736.95
SVCW Bond - 2009 Bond	656,144.00	-
SVCW Bond - 2014 Bond	1,145,613.40	-
SVCW Bond - 2015 Bond	1,019,906.45	-
SVCW Bond - 2018 Bond	1,834,712.50	-
SVCW Cash Contribution on 2018 Bond	6,416,002.01	-
SVCW SRF Loan - WWTP Phase 1	506,765.20	-
SVCW - Monthly Operating Payment	4,432,729.00	-
SWRCB	14,557.00	-
Safety Center Inc	5,308.00	-
San Mateo County	18,263.00	-
San Mateo County Assessor	305.00	-
San Mateo County Clerk	759.00	26.00
San Mateo CO Health Dept	2,473.00	-
San Mateo County Tax Collector	924.30	-
Rupert Sandoval	1,113.46	116.55
Santa Clara County	587.00	-
Robert J. Scheidt	263.86	-
Seekzen Systems	14,300.00	475.00
Shape Incorporated	30,147.54	30,147.54
Sharp Business Systems	7,271.58	1,036.78
Sharp Electronics Corporation	947.96	69.83
Signa Mechanical	9,160.58	-
Sitech Norcal	460.95	-

WEST BAY SANITARY DISTRICT

SUMMARY OF FY2019-20 PAYMENTS
(Through Withdrawal Order
01/14/2020 to 02/03/2020)

	TOTAL BY VENDOR - YTD 7/1/2019- 2/17/2020	WITHDRAWAL PERIOD 2/17/2020
REGULAR PAYABLES		
Snap On Industrial C/O	750.72	750.72
Desiree S Slater	28.00	-
Solarwinds	57.00	-
Spartan Tool LLC	3,888.22	-
Staples Credit Plan	8,943.84	-
Stevens Creek Quarry, Inc.	692.99	-
Summit Aerial Services Inc	2,750.00	-
Sutter EAP	1,249.25	-
Target Specialty Products	444.52	-
Tap Plastics Inc.	419.65	-
Teamsters Local No. 350	7,530.00	-
Teletrac Navman US LTD.	1,477.29	492.43
The Concept Genie	1,879.70	-
TFS-Zoom Imaging Solutions Inc	802.99	-
Toshiba Financial Services	801.78	-
Towne Ford Sales	9,622.72	-
TPX Communications	16,012.06	-
Underground Service Alert	10,828.20	-
United Rentals Northwest, Inc.	1,082.58	-
US Bank	1,091.86	-
U.S. Jetting, LLC.	2,491.11	-
V & A Consulting Engineers	18,998.75	-
Valley Heating & Cooling	1,883.00	-
Verizon Wireless	14,223.64	-
Vision Communications Co.	11,306.67	667.00
V.W. Housen & Associates	47,709.50	-
Weco Industries, Inc.	73,699.07	-
West Yost & Associates	36,727.67	-
Wex Bank	309.93	-
Woodard & Curran	102,993.19	4,177.62
Zanker Recycling	3,451.58	-
Zip's AW Direct	118.31	-
Zoom Imaging Solutions, Inc.	1,215.54	-
TOTAL REGULAR PAYABLES	26,389,345.08	857,417.32
SALARIES/WAGES & W/H		
Salaries/Wages - Net Pay	1,430,544.24	101,380.77
Directors Fees - Net Pay	11,397.09	-
PrimePay Fees	4,624.45	940.10
IRS - Federal Payroll Taxes	285,872.57	21,100.09
EDD - State Payroll Taxes	101,474.52	6,931.32
ICMA	146,395.74	11,181.80
Performance Merit Program - Net Pay	124,143.65	-
TOTAL SALARIES RELATED	2,104,452.26	141,534.08
TOTAL PAYABLES	28,493,797.34	998,951.40
SUMMARY		
TOTAL CHECKS		808,598.33
TOTAL WIRES		<u>460,353.07</u>
TOTAL PAYABLES		<u><u>1,268,951.40</u></u>

WEST BAY SANITARY DISTRICT
Schedule of Cash Receipt Deposits
01/31/2020-02/14/2020

DEPOSIT DATE	RECEIPT NUMBER	DESCRIPTION	AMOUNT
2/14/2020	461041	\$1000 deposit for 1200 Chestnut; Connected to 4B Permit# 16660 (\$170)	\$1,000.00
2/14/2020	461041	Credit Card	\$170.00
2/14/2020	461042	Permit: 88 Irving Ave, ATH	\$355.00
2/14/2020	461043	Reimbursement for CWEA lunch	\$197.62
2/14/2020	461044	Invoice 2019/20-013	\$1,497.00
2/14/2020	461045	Permit: 23 Sunset Ln, MP	\$290.00
2/14/2020	461046	Permit: 900 Menlo Oaks Dr, MP	\$290.00
2/14/2020	461047	Permit: 150 Pineview Ln, MP	\$290.00
2/14/2020	461048	Permit: 170 Pineview Ln, MP	\$290.00
2/14/2020	461049	Permit: 1655 Magnolia Ct, MP	\$290.00
2/14/2020	461050	Permit: 530 Laurel Ave, MP	\$170.00
2/14/2020	461051	Permit: 2124 Ashton Ave, MP	\$290.00
2/14/2020	461052	Permit: 86 Mesa Ct, ATH	\$290.00
2/14/2020	461053	Invoice 2019/20-040	\$588.50
2/14/2020	461054	1A new open trench permit #16672 for 450 Golden Oak Dr, PV	\$290.00
2/14/2020	461055	Permit: 401 Olive St, MP	\$290.00
2/14/2020	461056	CCTV Permit: 340 Stevick Dr, ATH	\$95.00
2/14/2020	461057	1 year bond; 109 Santa Maria, PV; Check# 2660 *** VOID BOND RECEIVED	\$0.00
2/14/2020	461058	Permit: 527 Bay Rd, MP	\$290.00
2/14/2020	461059	Postage: \$0.50	\$0.50
2/14/2020	461060	Permit: 1055 Atkinson Ln. MP	\$290.00
2/14/2020	461061	Permit: 751 Menlo Oaks Dr, MP	\$170.00
2/14/2020	461062	Connection Fee: 450 Golden Oak Drive, PV	\$8,501.00
2/14/2020	461063	Permit: 336 Walsh Rd, MP	\$290.00
2/14/2020	461064	1B Permit: 695 Valparaiso Ave & 1A Permit: 985 Windsor Dr	\$580.00
2/14/2020	461065	Permit: 229 University Dr, MP	\$290.00
2/14/2020	461066	SRF Reimbursement #17	\$400,943.00
2/14/2020	461067	NR-0400 : 95 Mesa Ct, ATH	\$456.80
2/14/2020	461068	Dividend Share from FY 1986/87-2013/14	\$27,614.00
2/14/2020	461069	Permit: 440 Blake St, MP	\$290.00
Total Deposit			<u>\$446,398.42</u>

THIS PAGE LEFT INTENTIONALLY BLANK



**WEST BAY SANITARY DISTRICT
AGENDA ITEM 4C**

To: Board of Directors

From: Phil Scott, District Manager

Subject: Bank of the West Monthly Investment Portfolio Statements

Attached are the monthly statements indicating the amount of each reserve fund the District holds in the Bank of the West Investment Portfolio and the to-date market values.

Quarterly reports on the Investment Portfolio will include more details on the investments of each reserve.

Recommendation

The District Manager recommends the District Board review and accept these statements by affirming and approving the items listed in the Consent Calendar.



WBSD - EMERGENCY CAPITAL RESERVE

Account Number:
Statement Period: 01/01/20 -01/31/20

WEST BAY SANITARY DISTRICT
 ATTN: PHILLIP L. SCOTT
 500 LAUREL STREET
 MENLO PARK CA 94025

Fiduciary
 Chuen Ying Lee
 (408) 645-3234
Portfolio
 Michael D. Smith
 (408) 490-2079

Asset Allocation

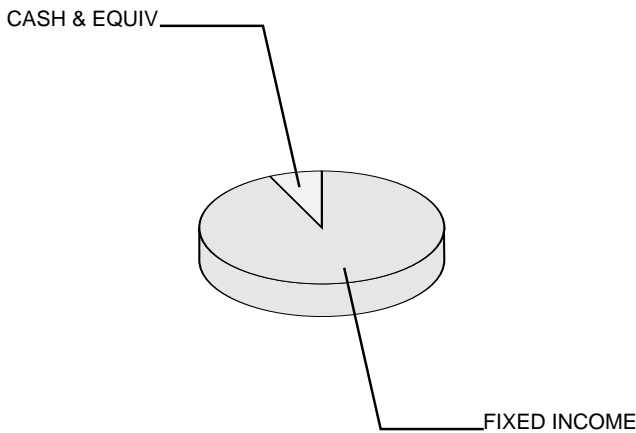

Asset Valuation

Description	Market Value	% of Account
Cash & Equiv	267,076.57	7.3%
Fixed Income	3,376,298.99	92.7%
Total Portfolio	\$ 3,643,375.56	100.0%
Accrued Income	16,408.62	
Total Valuation	\$ 3,659,784.18	

Market Reconciliation

	Current Period	Year To Date
Beginning Market Value	\$ 3,650,879.00	\$ 4,308,686.39
Income		
Interest.....	8,015.06	62,506.73
Purchased Income.....	-1,931.90	-2,923.75
Disbursements.....	-641.89	-1,700,215.06
Cash Transfers.....	0.00	8,700.00
Realized Gains/(Losses).....	-2,548.93	-22,400.91
Change In Accrued Income.....	-309.13	-8,400.74
Change In Market Appreciation/(Depreciation).....	5,148.63	31,270.40
Non-Cash Asset Changes.....	1,173.34	982,561.12
Ending Market Value	\$ 3,659,784.18	\$ 3,659,784.18



WBSD - EMERGENCY CAPITAL RESERVE

Account Number:
 Statement Period:

01/01/20 -
 01/31/20

Asset Position As of 01/31/20

Asset Description	Units	Market Value Cost	Est. Annual Income Accruals	Current Yield
Cash Equivalents				
Bank of The West Advantage Acct	267,076.570	267,076.57 267,076.57	4,059.00 465.42	1.52%
Total Cash Equivalents		\$ 267,076.57 \$ 267,076.57	4,059.00 465.42	1.52%
Fixed Income				
Federal Home Ln Mtg Corp Partn Gold Group #G13107 5.500% Dtd 03/01/2008 Due 07/01/2020 IPD14	81.510	81.55 180.04	4.00 0.37	5.50%
Federal Home Ln Mtg Corp Partn Gold Group #G11940 5.500% Dtd 03/01/2006 Due 05/01/2020 IPD14	114.020	114.07 221.11	6.00 0.52	5.50%
Federal Home Loan Bks Cons Bds Step Cpn Dtd 04/27/2017 Due 04/27/2022 Callable	120,000.000	122,443.20 119,730.00	2,760.00 720.66	2.25%
Federal Home Loan Bks Cons Bds 1.70% Dtd 07/27/2016 Due 07/27/2022 Callable	140,000.000	140,001.40 136,255.08	2,380.00 26.44	1.70%
Federal Farm Cr Bks Cons Systemwide Bds 1.90% Dtd 08/03/2017 Due 08/03/2022 Non-Callable	80,000.000	80,901.60 80,127.20	1,520.00 751.55	1.88%
Federal Farm Cr Bks Cons Systemwide Bds 1.64% Dtd 12/11/2019 Due 06/11/2021 Callable	110,000.000	110,002.20 110,000.00	1,804.00 250.55	1.64%
Federal Home Loan Bks Cons Bds 2.875% Dtd 08/27/2010 Due 09/11/2020 Non-Callable	80,000.000	80,616.80 81,129.60	2,300.00 894.44	2.85%
Federal Home Loan Bks Cons Bds 3.125% Dtd 11/17/2010 Due 12/11/2020 Non-Callable	110,000.000	111,534.50 111,474.66	3,437.00 486.97	3.08%
Federal Home Ln Mtg Corp 1.75% Dtd 12/30/2016 Due 12/30/2020 Callable	200,000.000	200,040.00 200,000.00	3,500.00 301.38	1.75%
Federal Home Ln Mtg Corp Medium Term Nts 1.625% Dtd 04/27/2017 Due 07/27/2020 Callable	40,000.000	40,013.60 40,000.00	650.00 169.72	1.62%



WBSD - EMERGENCY CAPITAL RESERVE

Account Number:
Statement Period:

01/01/20 -
01/31/20

Asset Position As of 01/31/20

Asset Description	Units	Market Value Cost	Est. Annual Income Accruals	Current Yield
Federal Home Ln Mtg Corp 1.65% Dtd 04/27/2017 Due 04/27/2020 Callable	150,000.000	150,061.50 149,652.69	2,475.00 646.25	1.65%
Federal Natl Mtg Assn 1.50% Dtd 04/27/2015 Due 06/22/2020 Non-Callable	25,000.000	24,991.75 25,053.00	375.00 40.62	1.50%
Federal Natl Mtg Assn 1.50% Dtd 10/19/2015 Due 11/30/2020 Non-Callable	275,000.000	274,953.25 274,592.75	4,125.00 698.95	1.50%
Federal Natl Mtg Assn 1.875% Dtd 11/16/2015 Due 12/28/2020 Non-Callable	40,000.000	40,154.00 40,254.80	750.00 68.74	1.87%
Federal Natl Mtg Assn 1.375% Dtd 02/05/2016 Due 02/26/2021 Non-Callable	60,000.000	59,945.40 59,816.45	825.00 355.20	1.38%
Federal Natl Mtg Assn 1.25% Dtd 08/19/2016 Due 08/17/2021 Non-Callable	130,000.000	129,790.70 129,088.85	1,625.00 740.27	1.25%
Federal Natl Mtg Assn 1.375% Dtd 10/07/2016 Due 10/07/2021 Non-Callable	60,000.000	60,001.80 59,661.49	825.00 261.25	1.37%
Federal Natl Mtg Assn 2.00% Dtd 01/09/2017 Due 01/05/2022 Non-Callable	60,000.000	60,720.00 60,142.80	1,200.00 86.66	1.98%
Federal Natl Mtg Assn 1.80% Dtd 10/26/2012 Due 10/26/2021 Callable	100,000.000	100,051.00 100,000.00	1,800.00 475.00	1.80%
Federal Natl Mtg Assn 1.50% Dtd 11/27/2012 Due 11/27/2020 Callable	200,000.000	199,848.00 197,747.43	3,000.00 533.33	1.50%
Federal Natl Mtg Assn 1.75% Dtd 09/28/2017 Due 09/28/2020 Callable	130,000.000	130,137.80 130,000.00	2,275.00 777.29	1.75%
Federal Home Ln Mtg Corp 2.375% Dtd 01/13/2012 Due 01/13/2022 Non-Callable	60,000.000	61,141.20 60,680.40	1,425.00 71.24	2.33%
Federal Home Ln Mtg Corp 1.375% Dtd 04/04/2013 Due 05/01/2020 Non-Callable	200,000.000	199,898.00 199,472.00	2,750.00 687.50	1.38%



WBSD - EMERGENCY CAPITAL RESERVE

Account Number:
Statement Period:

01/01/20 -
01/31/20

Asset Position As of 01/31/20

Asset Description	Units	Market Value Cost	Est. Annual Income Accruals	Current Yield
Federal Natl Mtg Assn Gtd Passthru CTF Pool #797828 5.000% Dtd 04/01/2005 Due 04/01/2020 IPD24	798.280	843.28 1,109.89	39.00 3.32	4.73%
Federal Natl Mtg Assn Gtd Passthru CTF Pool #819257 5.000% Dtd 05/01/2005 Due 04/01/2020 IPD24	744.360	743.70 1,104.72	37.00 3.10	5.00%
Home Depot Inc Sr Glbl Nt 2.00% Dtd 02/12/2016 Due 04/01/2021 Callable	60,000.000	60,319.80 59,878.80	1,200.00 399.99	1.99%
Indiana Univ Revs Student Fee Bds V Taxable 2.227% Dtd 10/26/2012 Due 08/01/2020 Callable	25,000.000	25,060.50 25,080.00	556.00 278.37	2.22%
Michigan St GO Ref Bds 2009a Taxable 6.95% Dtd 04/14/2009 Due 11/01/2020 Non-Callable	25,000.000	26,000.50 26,054.25	1,737.00 434.37	6.68%
New Hampshire Health & Ed Facs Taxable Univ Sys Issue B 2017 B Taxable 2.292% Dtd 12/06/2017 Due 07/01/2021 Non-Callable	25,000.000	25,189.50 25,158.75	573.00 47.75	2.27%
Pfizer Inc Sr Nt 5.20% Dtd 08/12/2015 Due 08/12/2020 Non-Callable	100,000.000	101,846.00 103,196.00	5,200.00 2,441.11	5.11%
San Francisco Calif City & Cnt Taxable Ref Bds 2019 A Taxable 1.814% Dtd 01/09/2020 Due 11/01/2020 Callable	50,000.000	50,037.50 50,025.00	907.00 55.42	1.81%
Small Business Admin Gtd Ln Pool Cfs 4.34% Dtd 03/17/2004 Due 03/01/2024	9,943.620	10,268.98 15,675.64	431.00 210.94	4.20%
Small Business Admin Gtd Ln Pool Cfs 4.084% Dtd 03/29/2011 Due 03/10/2021	5,645.420	5,762.56 6,741.83	230.00 122.34	4.00%
Starbucks Corp Sr Glbl 2.10% Dtd 02/04/2016 Due 02/04/2021 Callable	60,000.000	60,225.60 59,984.40	1,260.00 619.50	2.09%
3M Co Fr 2.00% Dtd 06/26/2012 Due 06/26/2022 Non-Callable	100,000.000	101,059.00 99,356.89	2,000.00 194.44	1.98%



WBSD - EMERGENCY CAPITAL RESERVE

Account Number:
Statement Period:

01/01/20 -
01/31/20

Asset Position As of 01/31/20

Asset Description	Units	Market Value Cost	Est. Annual Income Accruals	Current Yield
US Treasury Note 1.625% Dtd 11/30/2015 Due 11/30/2020	110,000.000	110,071.50 110,051.56	1,787.00 307.68	1.62%
US Treasury Note 0.125% Dtd 04/15/2016 Due 04/15/2021 Treasury Inflation Protection Security	108,525.000	108,286.25 108,262.16	135.00 40.40	0.13%
US Treasury Note 1.625% Dtd 03/15/2017 Due 03/15/2020	110,000.000	110,000.00 109,834.11	1,787.00 682.58	1.62%
US Treasury Note 2.75% Dtd 09/15/2018 Due 09/15/2021	100,000.000	102,166.00 99,695.31	2,750.00 1,050.13	2.69%
US Treasury Note 2.50% Dtd 01/31/2019 Due 01/31/2021	100,000.000	100,975.00 100,833.63	2,500.00 6.86	2.48%
Total Fixed Income		\$ 3,376,298.99 \$ 3,367,323.29	64,940.00 15,943.20	1.92%
Cash				
Principal Cash		0.00 0.00	0.00	0.00%
Income Cash		0.00 0.00	0.00	0.00%
Total Cash		\$ 0.00 \$ 0.00	0.00 0.00	0.00%
Total Market Value		\$ 3,643,375.56 \$ 3,634,399.86	68,999.00 16,408.62	1.89%
Total Market Value Plus Accruals		\$ 3,659,784.18		

Income Activity

	Date	Income Cash	Principal Cash
Interest Income			
Bank of The West Advantage Acct Int To 12/31/19	01/02/20		465.08
Federal Home Ln Mtg Corp Partn Gold Group #G13107 5.500% Dtd 03/01/2008 Due 07/01/2020 IPD14 Int For December 2019 on 138.15	01/15/20		0.63



WBSD - EMERGENCY CAPITAL RESERVE

Account Number:
 Statement Period:

01/01/20 -
 01/31/20

Income Activity			
	Date	Income Cash	Principal Cash
Federal Home Ln Mtg Corp Partn Gold Group #G11940 5.500% Dtd 03/01/2006 Due 05/01/2020 IPD14 Int For December 2019 on 190.31	01/15/20		0.87
Federal Home Loan Bks Cons Bds 2.00% Dtd 01/27/2016 Due 01/27/2021 Callable Int To 01/27/20 on 75,000	01/27/20		750.00
Federal Home Loan Bks Cons Bds 1.70% Dtd 07/27/2016 Due 07/27/2022 Callable Int To 01/27/20 on 140,000	01/27/20		1,190.00
Federal Home Ln Mtg Corp 2.00% Dtd 04/26/2017 Due 10/26/2021 Callable Interest At Full Call of	01/27/20		600.00
Federal Home Ln Mtg Corp 2.00% Dtd 10/12/2017 Due 10/12/2021 Callable Interest At Full Call of	01/13/20		500.00
Federal Natl Mtg Assn 2.00% Dtd 01/09/2017 Due 01/05/2022 Non-Callable Int To 01/05/20 on 60,000	01/06/20		600.00
Federal Home Ln Mtg Corp 2.375% Dtd 01/13/2012 Due 01/13/2022 Non-Callable Int To 01/13/20 on 60,000	01/13/20		712.50
Federal Home Ln Mtg Corp 1.50% Dtd 01/17/2017 Due 01/17/2020 Non-Callable Int To 01/17/20 on 250,000	01/17/20		1,875.00
Federal Natl Mtg Assn Gtd Passthru CTF Pool #797828 5.000% Dtd 04/01/2005 Due 04/01/2020 IPD24 Int For December 2019 on 1406.67	01/27/20		5.86
Federal Natl Mtg Assn Gtd Passthru CTF Pool #819257 5.000% Dtd 05/01/2005 Due 04/01/2020 IPD24 Int For December 2019 on 1114.24	01/27/20		4.64



WBSD - EMERGENCY CAPITAL RESERVE

Account Number:
 Statement Period:

01/01/20 -
 01/31/20

Income Activity			
	Date	Income Cash	Principal Cash
Small Business Admin Gtd Ln Pool Ctfs 7.59% Dtd 01/12/2000 Due 01/01/2020 Int To 01/01/20 on 1593.83	01/02/20		60.48
US Treasury Note 2.50% Dtd 01/31/2019 Due 01/31/2021 Int To 01/31/20 on 100,000	01/31/20		1,250.00
Total Interest Income		\$ 0.00	\$ 8,015.06
Purchased Income			
Federal Farm Cr Bks Cons Systemwide Bds 1.64% Dtd 12/11/2019 Due 06/11/2021 Callable Accrued Int To 01/28/20 Paid on Purchase of 110,000	01/28/20		-235.52
Federal Home Loan Bks Cons Bds 3.125% Dtd 11/17/2010 Due 12/11/2020 Non-Callable Accrued Int To 01/31/20 Paid on Purchase of 110,000	01/31/20		-477.43
Federal Natl Mtg Assn 1.80% Dtd 10/26/2012 Due 10/26/2021 Callable Accrued Int To 01/03/20 Paid on Purchase of 100,000	01/03/20		-335.00
Indiana Univ Revs Student Fee Bds V Taxable 2.227% Dtd 10/26/2012 Due 08/01/2020 Callable Accrued Int To 01/07/20 Paid on Purchase of 25,000	01/07/20		-239.71
Michigan St GO Ref Bds 2009a Taxable 6.95% Dtd 04/14/2009 Due 11/01/2020 Non-Callable Accrued Int To 01/06/20 Paid on Purchase of 25,000	01/06/20		-313.72
New Hampshire Health & Ed Facs Taxable Univ Sys Issue B 2017 B Taxable 2.292% Dtd 12/06/2017 Due 07/01/2021 Non-Callable Accrued Int To 01/07/20 Paid on Purchase of 25,000	01/07/20		-7.96



WBSD - EMERGENCY CAPITAL RESERVE

Account Number:
 Statement Period:

01/01/20 -
 01/31/20

Income Activity			
	Date	Income Cash	Principal Cash
US Treasury Note 1.625% Dtd 11/30/2015 Due 11/30/2020 Accrued Int To 01/27/20 Paid on Purchase of 110,000	01/27/20		-283.27
US Treasury Note 0.125% Dtd 04/15/2016 Due 04/15/2021 Treasury Inflation Protection Security Accrued Int To 01/29/20 Paid on Purchase of 108,529	01/29/20		-39.29
Total Purchased Income		\$ 0.00	\$ -1,931.90
Total Income		\$ 0.00	\$ 6,083.16

Disbursement Activity			
	Date	Income Cash	Principal Cash
Fees/Expenses			
Monthly Fee To 12/31/19	01/15/20		-641.89
Total Fees/Expenses		\$ 0.00	\$ -641.89
Total Disbursements		\$ 0.00	\$ -641.89

Purchase Activity			
	Date	Income Cash	Principal Cash
Bank of The West Advantage Acct Purchases (5) 01/01/20 To 01/31/20	01/31/20		-443,535.26
Federal Farm Cr Bks Cons Systemwide Bds 1.64% Dtd 12/11/2019 Due 06/11/2021 Callable Purchased 110000 01/27/20 From BOK Financial Securities, Inc. @ 100	01/28/20		-110,000.00
Federal Home Loan Bks Cons Bds 3.125% Dtd 11/17/2010 Due 12/11/2020 Non-Callable Purchased 110000 01/30/20 From Wells Fargo Securities, LLC @ 101.3406	01/31/20		-111,474.66



WBSD - EMERGENCY CAPITAL RESERVE

Account Number:
 Statement Period:

01/01/20 -
 01/31/20

Purchase Activity			
	Date	Income Cash	Principal Cash
Federal Natl Mtg Assn 1.80% Dtd 10/26/2012 Due 10/26/2021 Callable Purchased 100000 01/02/20 From Morgan Stanley & Co @ 100	01/03/20		-100,000.00
Indiana Univ Revs Student Fee Bds V Taxable 2.227% Dtd 10/26/2012 Due 08/01/2020 Callable Purchased 25000 01/03/20 From D A Davidson & Co @ 100.32	01/07/20		-25,080.00
Michigan St GO Ref Bds 2009a Taxable 6.95% Dtd 04/14/2009 Due 11/01/2020 Non-Callable Purchased 25000 01/02/20 From Headlands Holdings LLC @ 104.217	01/06/20		-26,054.25
New Hampshire Health & Ed Facs Taxable Univ Sys Issue B 2017 B Taxable 2.292% Dtd 12/06/2017 Due 07/01/2021 Non-Callable Purchased 25000 01/03/20 From D A Davidson & Co @ 100.635	01/07/20		-25,158.75
San Francisco Calif City & Cnt Taxable Ref Bds 2019 A Taxable 1.814% Dtd 01/09/2020 Due 11/01/2020 Callable Purchased 50000 01/02/20 From Tmc Bonds LLC @ 100.05	01/09/20		-50,025.00
US Treasury Note 1.625% Dtd 11/30/2015 Due 11/30/2020 Purchased 110000 01/24/20 From Wells Fargo Securities, LLC @ 100.046875	01/27/20		-110,051.56
US Treasury Note 0.125% Dtd 04/15/2016 Due 04/15/2021 Treasury Inflation Protection Security Purchased 108529 01/28/20 From Barclays Capital Inc Fixed Inc @ 99.7578125	01/29/20		-108,266.16
Total Purchases		\$ 0.00	\$ -1,109,645.64



WBSD - EMERGENCY CAPITAL RESERVE

Account Number:
 Statement Period:

01/01/20 -
 01/31/20

Sale Activity			
	Date	Proceeds	Realized Gain/Loss
Bank of The West Advantage Acct Sales (8) 01/01/20 To 01/31/20	01/31/20	556,499.34	
Federal Home Ln Mtg Corp Partn Gold Group #G13107 5.500% Dtd 03/01/2008 Due 07/01/2020 IPD14 Prin Pmt For December 2019	01/15/20	56.64	-68.46
Federal Home Ln Mtg Corp Partn Gold Group #G11940 5.500% Dtd 03/01/2006 Due 05/01/2020 IPD14 Prin Pmt For December 2019	01/15/20	76.29	-71.66
Federal Home Loan Bks Cons Bds 2.00% Dtd 01/27/2016 Due 01/27/2021 Callable Recd Proceeds on Full Call of 75,000 Par Value	01/27/20	75,000.00	731.46
Federal Home Ln Mtg Corp 2.00% Dtd 04/26/2017 Due 10/26/2021 Callable Recd Proceeds on Full Call of 120,000 Par Value	01/27/20	120,000.00	
Federal Home Ln Mtg Corp 2.00% Dtd 10/12/2017 Due 10/12/2021 Callable Recd Proceeds on Full Call of 100,000 Par Value	01/13/20	100,000.00	
Federal Home Ln Mtg Corp 1.50% Dtd 01/17/2017 Due 01/17/2020 Non-Callable Recd Proceeds on Maturity of 250,000 Par Value	01/17/20	250,000.00	
Federal Natl Mtg Assn Gtd Passthru CTF Pool #797828 5.000% Dtd 04/01/2005 Due 04/01/2020 IPD24 Prin Pmt For December 2019	01/27/20	608.39	-237.48
Federal Natl Mtg Assn Gtd Passthru CTF Pool #819257 5.000% Dtd 05/01/2005 Due 04/01/2020 IPD24 Prin Pmt For December 2019	01/27/20	369.88	-179.06



WBSD - EMERGENCY CAPITAL RESERVE

Account Number:
 Statement Period:

01/01/20 -
 01/31/20

Sale Activity			
	Date	Proceeds	Realized Gain/Loss
Small Business Admin Gtd Ln Pool Ctfs 7.59% Dtd 01/12/2000 Due 01/01/2020 Recd Proceeds on Maturity of 1,593.830 Par Value	01/02/20	1,593.83	-2,723.73
Total Sales		\$ 1,104,204.37	\$ -2,548.93

Non-Cash Activity		
	Date	Cost
Federal Home Loan Bks Cons Bds 2.00% Dtd 01/27/2016 Due 01/27/2021 Callable Accretion of Discount	01/27/20	365.72
Federal Home Loan Bks Cons Bds 1.70% Dtd 07/27/2016 Due 07/27/2022 Callable Accretion of Discount	01/27/20	748.98
Federal Home Ln Mtg Corp 1.65% Dtd 04/27/2017 Due 04/27/2020 Callable Accretion of Discount	01/31/20	119.74
Federal Natl Mtg Assn 1.375% Dtd 02/05/2016 Due 02/26/2021 Non-Callable Accretion of Discount	01/31/20	14.25
Federal Natl Mtg Assn 1.375% Dtd 10/07/2016 Due 10/07/2021 Non-Callable Accretion of Discount	01/31/20	16.71
Federal Natl Mtg Assn 2.00% Dtd 01/09/2017 Due 01/05/2022 Non-Callable Amortization of Premium	01/03/20	-34.80
Federal Natl Mtg Assn 1.50% Dtd 11/27/2012 Due 11/27/2020 Callable Accretion of Discount	01/31/20	91.00
Accretion of Discount	01/31/20	136.51



WBSD - EMERGENCY CAPITAL RESERVE

Account Number:
 Statement Period:

01/01/20 -
 01/31/20

Non-Cash Activity		
	Date	Cost
Federal Home Ln Mtg Corp 2.375% Dtd 01/13/2012 Due 01/13/2022 Non-Callable Amortization of Premium	01/13/20	-166.20
Federal Home Ln Mtg Corp 1.50% Dtd 01/17/2017 Due 01/17/2020 Non-Callable Amortization of Premium	01/17/20	-52.50
3M Co Fr 2.00% Dtd 06/26/2012 Due 06/26/2022 Non-Callable Accretion of Discount	01/31/20	22.27
US Treasury Note 0.125% Dtd 04/15/2016 Due 04/15/2021 Treasury Inflation Protection Security Inflationary Int Adjustment 01/30/20	01/30/20	-4.00
US Treasury Note 2.50% Dtd 01/31/2019 Due 01/31/2021 Amortization of Premium	01/31/20	-84.34
Total Non-Cash Transactions		\$ 1,173.34

SECURITY PRICES CONTAINED IN THIS STATEMENT ARE OBTAINED FROM THE MOST RELIABLE SOURCES AVAILABLE BUT ARE NOT GUARANTEED BY BANK OF THE WEST. QUOTED PRICES MAY NOT EQUAL ACTUAL PRICES BECAUSE OF SECURITY SIZE, MARKET PRICE, TERM AND DEMAND.



Electronic Funds Transfers

Preauthorized Transfers:

You may request an electronic fund transfer (EFT), such as an ACH transfer from or deposit to your account, by contacting your account Administrator. You may also preauthorize periodic EFTs by contacting your account Administrator. If you would like to know whether a preauthorized EFT has occurred, please contact your account Administrator at the phone number listed on the first page of your statement, or call 1-877-232-7321 (TTY 866-827-6167) between the hours of 8:00 A.M. to 5:00 P.M. Pacific Standard Time.

Error Resolution Notice:

If you think a statement or receipt is wrong or if you need more information about an EFT listed on a statement or receipt, telephone us at 1-877-232-7321 (TTY 866-827-6167) between the hours of 8:00 A.M. to 5:00 P.M. Pacific Standard Time, write to us at Bank of the West, 13300 Crossroads Parkway North, City of Industry, CA 91746, or e-mail us at WMGGIFSOoperations@bankofthewest.com as soon as possible. We must hear from you no later than 60 days after we sent the FIRST statement on which the problem or error appeared.

1. Tell us your name and account number (if any).
2. Tell us the dollar amount of the suspected error.
3. Describe the error or the transfer you are unsure about, and explain as clearly as you can why you believe it is an error or why you need more information.

If you contact us verbally, we may require that you send us your complaint or question in writing within 10 business days. We will investigate your complaint and will correct any error promptly. If we take more than 10 business days to do this, we will credit your account for the amount you think is in error, so that you will have the use of the money during the time it takes us to complete our investigation.



WBSD - CAPITAL PROJECT RESERVE

Account Number:
 Statement Period:

01/01/20 -
 01/31/20

WEST BAY SANITARY DISTRICT
 ATTN: PHILLIP L. SCOTT
 500 LAUREL STREET
 MENLO PARK CA 94025

Fiduciary
 Chuen Ying Lee
 (408) 645-3234
Portfolio
 Michael D. Smith
 (408) 490-2079

Asset Allocation

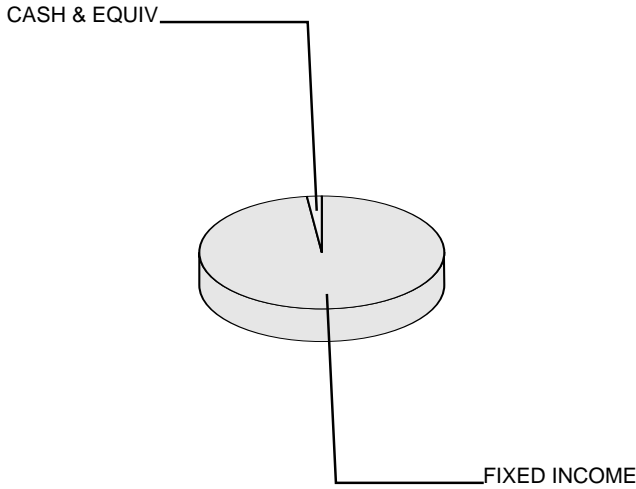

Asset Valuation

Description	Market Value	% of Account
Cash & Equiv	50,596.39	2.5%
Fixed Income	1,998,699.69	97.5%
Total Portfolio	\$ 2,049,296.08	100.0%
Accrued Income	10,228.78	
Total Valuation	\$ 2,059,524.86	

Market Reconciliation

	Current Period	Year To Date
Beginning Market Value	\$ 2,053,960.36	\$ 2,666,749.24
Income		
Interest.....	4,907.95	37,898.01
Purchased Income.....	-1,538.60	-2,530.45
Disbursements.....	-361.04	-640,731.17
Realized Gains/(Losses).....	-16.92	227.09
Change In Accrued Income.....	358.72	-5,505.56
Change In Market Appreciation/(Depreciation).....	2,619.35	10,418.56
Non-Cash Asset Changes.....	-404.96	-7,000.86
Ending Market Value	\$ 2,059,524.86	\$ 2,059,524.86



WBSD - CAPITAL PROJECT RESERVE

Account Number:
Statement Period:

01/01/20 -
01/31/20

Asset Position As of 01/31/20

Asset Description	Units	Market Value Cost	Est. Annual Income Accruals	Current Yield
Cash Equivalents				
Bank of The West Advantage Acct	50,596.390	50,596.39 50,596.39	769.00 247.87	1.52%
Total Cash Equivalents		\$ 50,596.39 \$ 50,596.39	769.00 247.87	1.52%
Fixed Income				
Federal Home Loan Bks Cons Bds Step Cpn Dtd 04/27/2017 Due 04/27/2022 Callable	50,000.000	51,018.00 49,887.50	1,150.00 300.27	2.25%
Federal Home Loan Bks Cons Bds 1.625% Dtd 09/30/2016 Due 09/30/2021 Callable	100,000.000	100,026.00 97,677.03	1,625.00 546.18	1.62%
Federal Farm Cr Bks Cons Systemwide Bds 1.55% Dtd 06/21/2016 Due 12/21/2020 Callable	32,000.000	31,962.88 32,000.00	496.00 55.11	1.55%
Federal Farm Cr Bks Cons Systemwide Bds 1.90% Dtd 07/19/2017 Due 07/19/2022 Non-Callable	60,000.000	60,670.80 60,145.80	1,140.00 38.00	1.88%
Federal Farm Cr Bks Cons Systemwide Bds 1.90% Dtd 08/03/2017 Due 08/03/2022 Non-Callable	60,000.000	60,676.20 60,095.40	1,140.00 563.66	1.88%
Federal Farm Cr Bks Cons Systemwide Bds 1.64% Dtd 12/11/2019 Due 06/11/2021 Callable	30,000.000	30,000.60 30,000.00	492.00 68.33	1.64%
Federal Home Loan Bks Cons Bds 4.625% Dtd 05/25/2005 Due 06/12/2020 Non-Callable	50,000.000	50,541.50 50,761.50	2,312.00 314.75	4.58%
Federal Farm Cr Bks Cons Systemwide Bds 4.75% Dtd 09/21/2005 Due 09/21/2020 Non-Callable	125,000.000	127,552.50 129,157.50	5,937.00 2,144.09	4.65%
Federal Home Loan Bks Cons Bds 2.875% Dtd 08/27/2010 Due 09/11/2020 Non-Callable	100,000.000	100,771.00 101,412.00	2,875.00 1,118.05	2.85%
Federal Home Ln Mtg Corp 1.50% Dtd 09/30/2016 Due 03/30/2021 Callable	50,000.000	50,004.50 50,000.00	750.00 252.08	1.50%



WBSD - CAPITAL PROJECT RESERVE

Account Number:
Statement Period:

01/01/20 -
01/31/20

Asset Position As of 01/31/20

Asset Description	Units	Market Value Cost	Est. Annual Income Accruals	Current Yield
Federal Home Ln Mtg Corp 1.75% Dtd 12/30/2016 Due 12/30/2020 Callable	180,000.000	180,036.00 180,000.00	3,150.00 271.25	1.75%
Federal Home Ln Mtg Corp 1.65% Dtd 04/27/2017 Due 04/27/2020 Callable	100,000.000	100,041.00 99,768.34	1,650.00 430.83	1.65%
Federal Natl Mtg Assn 1.50% Dtd 04/27/2015 Due 06/22/2020 Non-Callable	40,000.000	39,986.80 40,084.80	600.00 65.00	1.50%
Federal Natl Mtg Assn 1.50% Dtd 10/19/2015 Due 11/30/2020 Non-Callable	40,000.000	39,993.20 40,120.40	600.00 101.66	1.50%
Federal Natl Mtg Assn 1.875% Dtd 11/16/2015 Due 12/28/2020 Non-Callable	100,000.000	100,385.00 100,637.00	1,875.00 171.87	1.87%
Federal Natl Mtg Assn 1.375% Dtd 02/05/2016 Due 02/26/2021 Non-Callable	60,000.000	59,945.40 59,816.45	825.00 355.20	1.38%
Federal Natl Mtg Assn 1.375% Dtd 10/07/2016 Due 10/07/2021 Non-Callable	60,000.000	60,001.80 59,661.49	825.00 261.25	1.37%
Federal Natl Mtg Assn 2.00% Dtd 01/09/2017 Due 01/05/2022 Non-Callable	120,000.000	121,440.00 120,285.60	2,400.00 173.33	1.98%
Federal Natl Mtg Assn 1.875% Dtd 04/10/2017 Due 04/05/2022 Non-Callable	60,000.000	60,663.60 60,126.60	1,125.00 362.50	1.85%
Federal Natl Mtg Assn 1.80% Dtd 10/26/2012 Due 10/26/2021 Callable	100,000.000	100,051.00 100,000.00	1,800.00 475.00	1.80%
Federal Home Ln Mtg Corp 2.375% Dtd 01/13/2012 Due 01/13/2022 Non-Callable	120,000.000	122,282.40 121,360.80	2,850.00 142.50	2.33%
Federal Natl Mtg Assn Gtd Passthru CTF Pool #797828 5.000% Dtd 04/01/2005 Due 04/01/2020 IPD24	399.140	421.64 421.34	19.00 1.66	4.73%
Indiana Univ Revs Student Fee Bds V Taxable 2.227% Dtd 10/26/2012 Due 08/01/2020 Callable	25,000.000	25,060.50 25,080.00	556.00 278.37	2.22%



WBSD - CAPITAL PROJECT RESERVE

Account Number:
 Statement Period:

01/01/20 -
 01/31/20

Asset Position As of 01/31/20

Asset Description	Units	Market Value Cost	Est. Annual Income Accruals	Current Yield
Michigan St GO Ref Bds 2009a Taxable 6.95% Dtd 04/14/2009 Due 11/01/2020 Non-Callable	25,000.000	26,000.50 26,054.25	1,737.00 434.37	6.68%
New York St Dorm Auth St Pers Income Tax Rev Bds 2010c Taxable 4.554% Dtd 03/11/2010 Due 02/15/2021 Callable	25,000.000	25,649.00 25,685.75	1,138.00 524.98	4.44%
San Francisco Calif City & Cnt Taxable Ref Bds 2019 A Taxable 1.814% Dtd 01/09/2020 Due 11/01/2020 Callable	50,000.000	50,037.50 50,025.00	907.00 55.42	1.81%
US Treasury Note 1.625% Dtd 11/30/2015 Due 11/30/2020	30,000.000	30,019.50 30,014.06	487.00 83.90	1.62%
US Treasury Note 0.125% Dtd 04/15/2016 Due 04/15/2021 Treasury Inflation Protection Security	32,557.500	32,485.87 32,478.65	40.00 12.12	0.13%
US Treasury Note 1.625% Dtd 03/15/2017 Due 03/15/2020	60,000.000	60,000.00 59,925.30	975.00 372.32	1.62%
US Treasury Note 2.50% Dtd 01/31/2019 Due 01/31/2021	100,000.000	100,975.00 100,833.63	2,500.00 6.86	2.48%
Total Fixed Income		\$ 1,998,699.69 \$ 1,993,516.19	43,976.00 9,980.91	2.20%
Cash				
Principal Cash		0.00 0.00	0.00	0.00%
Income Cash		0.00 0.00	0.00	0.00%
Total Cash		\$ 0.00 \$ 0.00	0.00 0.00	0.00%
Total Market Value		\$ 2,049,296.08 \$ 2,044,112.58	44,745.00 10,228.78	2.18%
Total Market Value Plus Accruals		\$ 2,059,524.86		



WBSD - CAPITAL PROJECT RESERVE

Account Number:
Statement Period:

01/01/20 -
01/31/20

Income Activity			
	Date	Income Cash	Principal Cash
Interest Income			
Bank of The West Advantage Acct Int To 12/31/19	01/02/20		460.02
Federal Farm Cr Bks Cons Systemwide Bds 1.90% Dtd 07/19/2017 Due 07/19/2022 Non-Callable Int To 01/19/20 on 60,000	01/21/20		570.00
Federal Natl Mtg Assn 2.00% Dtd 01/09/2017 Due 01/05/2022 Non-Callable Int To 01/05/20 on 120,000	01/06/20		1,200.00
Federal Home Ln Mtg Corp 2.375% Dtd 01/13/2012 Due 01/13/2022 Non-Callable Int To 01/13/20 on 120,000	01/13/20		1,425.00
Federal Natl Mtg Assn Gtd Passthru CTF Pool #797828 5.000% Dtd 04/01/2005 Due 04/01/2020 IPD24 Int For December 2019 on 703.34	01/27/20		2.93
US Treasury Note 2.50% Dtd 01/31/2019 Due 01/31/2021 Int To 01/31/20 on 100,000	01/31/20		1,250.00
Total Interest Income		\$ 0.00	\$ 4,907.95
Purchased Income			
Federal Farm Cr Bks Cons Systemwide Bds 1.55% Dtd 06/21/2016 Due 12/21/2020 Callable Accrued Int To 01/28/20 Paid on Purchase of 32,000	01/28/20		-50.98
Federal Farm Cr Bks Cons Systemwide Bds 1.64% Dtd 12/11/2019 Due 06/11/2021 Callable Accrued Int To 01/28/20 Paid on Purchase of 30,000	01/28/20		-64.23
Federal Natl Mtg Assn 1.80% Dtd 10/26/2012 Due 10/26/2021 Callable Accrued Int To 01/03/20 Paid on Purchase of 100,000	01/03/20		-335.00



WBSD - CAPITAL PROJECT RESERVE

Account Number:
 Statement Period:

01/01/20 -
 01/31/20

Income Activity			
	Date	Income Cash	Principal Cash
Indiana Univ Revs Student Fee Bds V Taxable 2.227% Dtd 10/26/2012 Due 08/01/2020 Callable Accrued Int To 01/07/20 Paid on Purchase of 25,000	01/07/20		-239.71
Michigan St GO Ref Bds 2009a Taxable 6.95% Dtd 04/14/2009 Due 11/01/2020 Non-Callable Accrued Int To 01/06/20 Paid on Purchase of 25,000	01/06/20		-313.72
New York St Dorm Auth St Pers Income Tax Rev Bds 2010c Taxable 4.554% Dtd 03/11/2010 Due 02/15/2021 Callable Accrued Int To 01/07/20 Paid on Purchase of 25,000	01/07/20		-445.92
US Treasury Note 1.625% Dtd 11/30/2015 Due 11/30/2020 Accrued Int To 01/27/20 Paid on Purchase of 30,000	01/27/20		-77.25
US Treasury Note 0.125% Dtd 04/15/2016 Due 04/15/2021 Treasury Inflation Protection Security Accrued Int To 01/29/20 Paid on Purchase of 32,558.700	01/29/20		-11.79
Total Purchased Income		\$ 0.00	\$ -1,538.60
Total Income		\$ 0.00	\$ 3,369.35

Disbursement Activity			
	Date	Income Cash	Principal Cash
Fees/Expenses			
Monthly Fee To 12/31/19	01/15/20		-361.04
Total Fees/Expenses		\$ 0.00	\$ -361.04
Total Disbursements		\$ 0.00	\$ -361.04



WBSD - CAPITAL PROJECT RESERVE

Account Number:
 Statement Period:

01/01/20 -
 01/31/20

Purchase Activity			
	Date	Income Cash	Principal Cash
Bank of The West Advantage Acct Purchases (4) 01/01/20 To 01/31/20	01/31/20		-3,705.02
Federal Farm Cr Bks Cons Systemwide Bds 1.55% Dtd 06/21/2016 Due 12/21/2020 Callable Purchased 32000 01/27/20 From D A Davidson & Co @ 100	01/28/20		-32,000.00
Federal Farm Cr Bks Cons Systemwide Bds 1.64% Dtd 12/11/2019 Due 06/11/2021 Callable Purchased 30000 01/27/20 From BOK Financial Securities, Inc. @ 100	01/28/20		-30,000.00
Federal Natl Mtg Assn 1.80% Dtd 10/26/2012 Due 10/26/2021 Callable Purchased 100000 01/02/20 From Morgan Stanley & Co @ 100	01/03/20		-100,000.00
Indiana Univ Revs Student Fee Bds V Taxable 2.227% Dtd 10/26/2012 Due 08/01/2020 Callable Purchased 25000 01/03/20 From D A Davidson & Co @ 100.32	01/07/20		-25,080.00
Michigan St GO Ref Bds 2009a Taxable 6.95% Dtd 04/14/2009 Due 11/01/2020 Non-Callable Purchased 25000 01/02/20 From Headlands Holdings LLC @ 104.217	01/06/20		-26,054.25
New York St Dorm Auth St Pers Income Tax Rev Bds 2010c Taxable 4.554% Dtd 03/11/2010 Due 02/15/2021 Callable Purchased 25000 01/03/20 From D A Davidson & Co @ 102.743	01/07/20		-25,685.75
San Francisco Calif City & Cnt Taxable Ref Bds 2019 A Taxable 1.814% Dtd 01/09/2020 Due 11/01/2020 Callable Purchased 50000 01/02/20 From Tmc Bonds LLC @ 100.05	01/09/20		-50,025.00



WBSD - CAPITAL PROJECT RESERVE

Account Number:
 Statement Period:

01/01/20 -
 01/31/20

Purchase Activity			
	Date	Income Cash	Principal Cash
US Treasury Note 1.625% Dtd 11/30/2015 Due 11/30/2020 Purchased 30000 01/24/20 From Wells Fargo Securities, LLC @ 100.046875	01/27/20		-30,014.06
US Treasury Note 0.125% Dtd 04/15/2016 Due 04/15/2021 Treasury Inflation Protection Security Purchased 32558.700 01/28/20 From Barclays Capital Inc Fixed Inc @ 99.7578125	01/29/20		-32,479.85
Total Purchases		\$ 0.00	\$ -355,043.93

Sale Activity			
	Date	Proceeds	Realized Gain/Loss
Bank of The West Advantage Acct Sales (8) 01/01/20 To 01/31/20	01/31/20	351,731.42	
Federal Natl Mtg Assn Gtd Passthru CTF Pool #797828 5.000% Dtd 04/01/2005 Due 04/01/2020 IPD24 Prin Pmt For December 2019	01/27/20	304.20	-16.92
Total Sales		\$ 352,035.62	\$ -16.92

Non-Cash Activity		
	Date	Cost
Federal Farm Cr Bks Cons Systemwide Bds 1.90% Dtd 07/19/2017 Due 07/19/2022 Non-Callable Amortization of Premium	01/17/20	-28.20
Federal Home Ln Mtg Corp 1.65% Dtd 04/27/2017 Due 04/27/2020 Callable Accretion of Discount	01/31/20	79.82
Federal Natl Mtg Assn 1.375% Dtd 02/05/2016 Due 02/26/2021 Non-Callable Accretion of Discount	01/31/20	14.25



WBSD - CAPITAL PROJECT RESERVE

Account Number:
 Statement Period:

01/01/20 -
 01/31/20

Non-Cash Activity		
	Date	Cost
Federal Natl Mtg Assn 1.375% Dtd 10/07/2016 Due 10/07/2021 Non-Callable Accretion of Discount	01/31/20	16.71
Federal Natl Mtg Assn 2.00% Dtd 01/09/2017 Due 01/05/2022 Non-Callable Amortization of Premium	01/03/20	-69.60
Federal Home Ln Mtg Corp 2.375% Dtd 01/13/2012 Due 01/13/2022 Non-Callable Amortization of Premium	01/13/20	-332.40
US Treasury Note 0.125% Dtd 04/15/2016 Due 04/15/2021 Treasury Inflation Protection Security Inflationary Int Adjustment 01/30/20	01/30/20	-1.20
US Treasury Note 2.50% Dtd 01/31/2019 Due 01/31/2021 Amortization of Premium	01/31/20	-84.34
Total Non-Cash Transactions		\$ -404.96

SECURITY PRICES CONTAINED IN THIS STATEMENT ARE OBTAINED FROM THE MOST RELIABLE SOURCES AVAILABLE BUT ARE NOT GUARANTEED BY BANK OF THE WEST. QUOTED PRICES MAY NOT EQUAL ACTUAL PRICES BECAUSE OF SECURITY SIZE, MARKET PRICE, TERM AND DEMAND.



Electronic Funds Transfers

Preauthorized Transfers:

You may request an electronic fund transfer (EFT), such as an ACH transfer from or deposit to your account, by contacting your account Administrator. You may also preauthorize periodic EFTs by contacting your account Administrator. If you would like to know whether a preauthorized EFT has occurred, please contact your account Administrator at the phone number listed on the first page of your statement, or call 1-877-232-7321 (TTY 866-827-6167) between the hours of 8:00 A.M. to 5:00 P.M. Pacific Standard Time.

Error Resolution Notice:

If you think a statement or receipt is wrong or if you need more information about an EFT listed on a statement or receipt, telephone us at 1-877-232-7321 (TTY 866-827-6167) between the hours of 8:00 A.M. to 5:00 P.M. Pacific Standard Time, write to us at Bank of the West, 13300 Crossroads Parkway North, City of Industry, CA 91746, or e-mail us at WMGGIFSOperations@bankofthewest.com as soon as possible. We must hear from you no later than 60 days after we sent the FIRST statement on which the problem or error appeared.

1. Tell us your name and account number (if any).
2. Tell us the dollar amount of the suspected error.
3. Describe the error or the transfer you are unsure about, and explain as clearly as you can why you believe it is an error or why you need more information.

If you contact us verbally, we may require that you send us your complaint or question in writing within 10 business days. We will investigate your complaint and will correct any error promptly. If we take more than 10 business days to do this, we will credit your account for the amount you think is in error, so that you will have the use of the money during the time it takes us to complete our investigation.



WBSD - OPERATING RESERVE

Account Number:
 Statement Period:

01/01/20 -
 01/31/20

WEST BAY SANITARY DISTRICT
 ATTN: PHILLIP L. SCOTT
 500 LAUREL STREET
 MENLO PARK CA 94025

Fiduciary
 Chuen Ying Lee
 (408) 645-3234
Portfolio
 Michael D. Smith
 (408) 490-2079

Asset Allocation

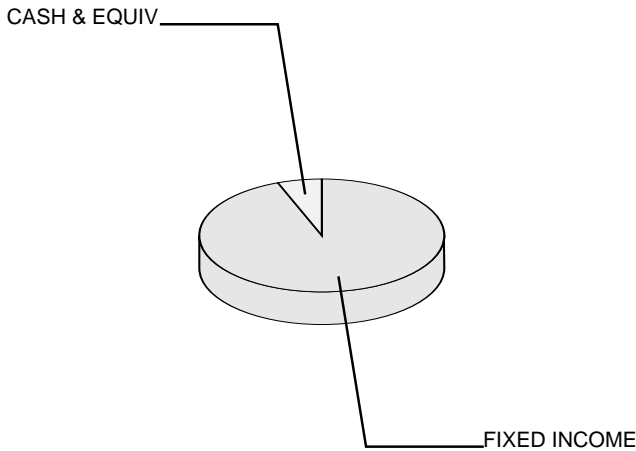

Asset Valuation

Description	Market Value	% of Account
Cash & Equiv	466,444.04	5.8%
Fixed Income	7,583,096.99	94.2%
Total Portfolio	\$ 8,049,541.03	100.0%
Accrued Income	38,443.28	
Total Valuation	\$ 8,087,984.31	

Market Reconciliation

	Current Period	Year To Date
Beginning Market Value	\$ 8,062,360.78	\$ 7,191,676.47
Income		
Interest.....	16,870.67	103,651.22
Purchased Income.....	-2,591.37	-4,575.06
Disbursements.....	-1,417.17	-1,403,194.63
Cash Transfers.....	0.00	9,000.00
Realized Gains/(Losses).....	-47.94	4,101.58
Change In Accrued Income.....	-385.82	420.43
Change In Market Appreciation/(Depreciation).....	14,442.17	34,756.14
Non-Cash Asset Changes.....	-1,247.01	2,152,148.16
Ending Market Value	\$ 8,087,984.31	\$ 8,087,984.31



WBSD - OPERATING RESERVE

Account Number:
Statement Period:

01/01/20 -
01/31/20

Asset Position As of 01/31/20

Asset Description	Units	Market Value Cost	Est. Annual Income Accruals	Current Yield
Cash Equivalents				
Bank of The West Advantage Acct	466,444.040	466,444.04 466,444.04	7,089.00 924.95	1.52%
Total Cash Equivalents		\$ 466,444.04 \$ 466,444.04	7,089.00 924.95	1.52%
Fixed Income				
Atlantic Richfield Co Deb 8.25% Dtd 02/01/1992 Due 02/01/2022 Non-Callable	15,000.000	16,772.70 17,030.70	1,237.00 618.75	7.38%
Capital One Bk USA Natl Assn CTF Dep 1.40% Dtd 09/28/2016 Due 09/28/2020 Non-Callable	100,000.000	99,764.00 100,000.00	1,400.00 483.28	1.40%
Constellation Brands Inc Sr Gbl Nt 2.25% Dtd 11/07/2017 Due 11/06/2020 Callable	75,000.000	75,262.50 74,824.50	1,687.00 398.43	2.24%
Federal Home Ln Mtg Corp Partn Gold Group #G13107 5.500% Dtd 03/01/2008 Due 07/01/2020 IPD14	81.140	81.18 85.25	4.00 0.37	5.50%
Federal Home Ln Mtg Corp Partn Gold Group #G11940 5.500% Dtd 03/01/2006 Due 05/01/2020 IPD14	116.600	116.65 123.02	6.00 0.53	5.50%
Federal Home Loan Bks Cons Bds 1.875% Dtd 11/30/2016 Due 11/29/2021 Non-Callable	200,000.000	201,778.00 198,439.73	3,750.00 645.83	1.86%
Federal Home Loan Bks Cons Bds 1.85% Dtd 08/15/2017 Due 08/15/2022 Non-Callable	235,000.000	237,589.70 236,142.10	4,347.00 2,004.68	1.83%
Federal Farm Cr Bks Cons Systemwide Bds 2.40% Dtd 06/17/2015 Due 06/17/2022 Non-Callable	235,000.000	240,273.40 238,546.15	5,640.00 689.33	2.35%
Federal Farm Cr Bks Cons Systemwide Bds 1.72% Dtd 07/26/2017 Due 07/26/2021 Non-Callable	235,000.000	236,271.35 235,277.30	4,042.00 56.13	1.71%
Federal Farm Cr Bks Cons Systemwide Bds 1.62% Dtd 09/11/2017 Due 09/11/2020 Callable	180,000.000	180,001.80 178,953.05	2,916.00 1,134.00	1.62%



WBSD - OPERATING RESERVE

Account Number:
Statement Period:

01/01/20 -
01/31/20

Asset Position As of 01/31/20

Asset Description	Units	Market Value Cost	Est. Annual Income Accruals	Current Yield
Federal Farm Cr Bks Cons Systemwide Bds 1.64% Dtd 12/11/2019 Due 06/11/2021 Callable	100,000.000	100,002.00 100,000.00	1,640.00 227.77	1.64%
Federal Home Loan Bks Cons Bds 4.625% Dtd 05/25/2005 Due 06/12/2020 Non-Callable	200,000.000	202,166.00 203,046.00	9,250.00 1,259.02	4.58%
Federal Home Loan Bks Cons Bds 2.875% Dtd 08/27/2010 Due 09/11/2020 Non-Callable	60,000.000	60,462.60 60,847.20	1,725.00 670.83	2.85%
Federal Home Loan Bks Cons Bds 1.625% Dtd 11/07/2012 Due 12/10/2021 Non-Callable	235,000.000	236,306.60 234,353.75	3,818.00 540.98	1.62%
Federal Home Loan Bks Cons Bds 1.75% Dtd 06/03/2013 Due 06/12/2020 Non-Callable	60,000.000	60,043.80 60,070.20	1,050.00 142.91	1.75%
Federal Home Ln Mtg Corp Step Cpn Dtd 09/30/2016 Due 09/30/2021 Callable	200,000.000	199,936.00 199,800.00	3,000.00 1,006.94	1.50%
Federal Home Ln Mtg Corp 1.75% Dtd 12/30/2016 Due 12/30/2020 Callable	120,000.000	120,024.00 120,000.00	2,100.00 180.83	1.75%
Federal Home Ln Mtg Corp Medium Term Nts 1.625% Dtd 04/27/2017 Due 07/27/2020 Callable	40,000.000	40,013.60 40,000.00	650.00 169.72	1.62%
Federal Home Ln Mtg Corp 1.60% Dtd 05/15/2017 Due 05/15/2020 Callable	240,000.000	240,014.40 240,000.00	3,840.00 810.66	1.60%
Federal Home Ln Mtg Corp 1.65% Dtd 01/27/2020 Due 04/27/2022 Callable	100,000.000	100,021.00 99,990.00	1,650.00 18.33	1.65%
Federal Natl Mtg Assn 1.50% Dtd 10/19/2015 Due 11/30/2020 Non-Callable	150,000.000	149,974.50 149,575.50	2,250.00 381.24	1.50%
Federal Natl Mtg Assn 1.875% Dtd 11/16/2015 Due 12/28/2020 Non-Callable	60,000.000	60,231.00 60,382.20	1,125.00 103.12	1.87%
Federal Natl Mtg Assn 1.375% Dtd 02/05/2016 Due 02/26/2021 Non-Callable	325,000.000	324,704.25 323,088.06	4,468.00 1,924.04	1.38%



WBSD - OPERATING RESERVE

Account Number:
Statement Period:

01/01/20 -
01/31/20

Asset Position As of 01/31/20

Asset Description	Units	Market Value Cost	Est. Annual Income Accruals	Current Yield
Federal Natl Mtg Assn 1.25% Dtd 05/16/2016 Due 05/06/2021 Non-Callable	290,000.000	289,498.30 288,681.13	3,625.00 855.90	1.25%
Federal Natl Mtg Assn 1.375% Dtd 10/07/2016 Due 10/07/2021 Non-Callable	325,000.000	325,009.75 323,331.38	4,468.00 1,415.10	1.37%
Federal Natl Mtg Assn 2.00% Dtd 01/09/2017 Due 01/05/2022 Non-Callable	505,000.000	511,060.00 505,826.61	10,100.00 729.44	1.98%
Federal Natl Mtg Assn 1.875% Dtd 04/10/2017 Due 04/05/2022 Non-Callable	160,000.000	161,769.60 160,892.80	3,000.00 966.66	1.85%
Federal Natl Mtg Assn 1.80% Dtd 10/26/2012 Due 10/26/2021 Callable	200,000.000	200,102.00 200,000.00	3,600.00 950.00	1.80%
Federal Home Ln Mtg Corp 2.375% Dtd 01/13/2012 Due 01/13/2022 Non-Callable	325,000.000	331,181.50 329,404.60	7,718.00 385.93	2.33%
Federal Home Ln Mtg Corp 1.375% Dtd 04/04/2013 Due 05/01/2020 Non-Callable	50,000.000	49,974.50 49,970.22	687.00 171.87	1.38%
Federal Natl Mtg Assn Gtd Passthru CTF Pool #797828 5.000% Dtd 04/01/2005 Due 04/01/2020 IPD24	852.810	900.88 900.25	42.00 3.55	4.73%
GE Capital Internotes Fr 5.50% Dtd 11/05/2009 Due 11/15/2021 Non-Callable	50,000.000	52,559.50 53,032.00	2,750.00 580.55	5.23%
Home Depot Inc Sr Gbl Nt 2.00% Dtd 02/12/2016 Due 04/01/2021 Callable	50,000.000	50,266.50 49,899.00	1,000.00 333.33	1.99%
Indiana Univ Revs Student Fee Bds V Taxable 2.227% Dtd 10/26/2012 Due 08/01/2020 Callable	25,000.000	25,060.50 25,080.00	556.00 278.38	2.22%
Michigan St GO Ref Bds 2009a Taxable 6.95% Dtd 04/14/2009 Due 11/01/2020 Non-Callable	25,000.000	26,000.50 26,054.25	1,737.00 434.36	6.68%
Ncua Guaran Nts Tr Ser 2010 R1 Cl I A Fltg Rate Dtd 10/27/2010 Due 10/07/2020	79,784.230	79,908.66 79,983.69	1,772.00 118.39	2.22%



WBSD - OPERATING RESERVE

Account Number:
Statement Period:

01/01/20 -
01/31/20

Asset Position As of 01/31/20

Asset Description	Units	Market Value Cost	Est. Annual Income Accruals	Current Yield
New Hampshire Health & Ed Facs Taxable Univ Sys Issue B 2017 B Taxable 2.292% Dtd 12/06/2017 Due 07/01/2021 Non-Callable	25,000.000	25,189.50 25,158.75	573.00 47.75	2.27%
New York St Dorm Auth St Pers Income Tax Rev Bds 2010c Taxable 4.554% Dtd 03/11/2010 Due 02/15/2021 Callable	25,000.000	25,649.00 25,685.75	1,138.00 524.97	4.44%
Philip Morris Intl Inc Sr Nt 4.50% Dtd 03/26/2010 Due 03/26/2020 Non-Callable	80,000.000	80,332.00 80,988.80	3,600.00 1,250.00	4.48%
Port Morrow Ore Transmission F Rev Bds Taxable 2.737% Dtd 08/26/2015 Due 09/01/2021 Callable	200,000.000	203,374.00 204,378.00	5,474.00 2,280.83	2.69%
San Francisco Calif City & Cnt Taxable Ref Bds 2019 A Taxable 1.814% Dtd 01/09/2020 Due 11/01/2020 Callable	50,000.000	50,037.50 50,025.00	907.00 55.42	1.81%
Starbucks Corp Sr Gbl 2.10% Dtd 02/04/2016 Due 02/04/2021 Callable	50,000.000	50,188.00 49,987.00	1,050.00 516.25	2.09%
3M Co Fr 2.00% Dtd 06/26/2012 Due 06/26/2022 Non-Callable	100,000.000	101,059.00 99,356.89	2,000.00 194.44	1.98%
US Treasury Note 1.625% Dtd 11/30/2015 Due 11/30/2020	425,000.000	425,276.25 421,285.94	6,906.00 1,188.78	1.62%
US Treasury Note 0.125% Dtd 04/15/2016 Due 04/15/2021 Treasury Inflation Protection Security	97,672.500	97,457.62 97,435.94	122.00 36.36	0.13%
US Treasury Note 2.00% Dtd 07/31/2013 Due 07/31/2020	40,000.000	40,079.60 39,898.24	800.00 2.19	2.00%
US Treasury Note 1.625% Dtd 03/15/2017 Due 03/15/2020	120,000.000	120,000.00 119,850.61	1,950.00 744.64	1.62%
US Treasury Note 2.75% Dtd 09/15/2018 Due 09/15/2021	100,000.000	102,166.00 99,695.31	2,750.00 1,050.13	2.69%
US Treasury Note 2.50% Dtd 01/31/2019 Due 01/31/2021	200,000.000	201,950.00 201,667.26	5,000.00 13.73	2.48%



WBSD - OPERATING RESERVE

Account Number:
Statement Period:

01/01/20 -
01/31/20

Asset Position As of 01/31/20

Asset Description	Units	Market Value Cost	Est. Annual Income Accruals	Current Yield
United Technologies Corp Sr Gbl 2.30% Dtd 05/04/2017 Due 05/04/2022 Callable	250,000.000	253,005.00 243,390.08	5,750.00 1,389.58	2.27%
Waco Tex Indpt Sch Dist Ref Bds Taxable 4.00% Dtd 12/01/2012 Due 02/15/2020 Non-Callable	270,000.000	270,172.80 273,588.30	10,800.00 4,980.00	4.00%
Wells Fargo & Co New Sr Gbl 2.50% Dtd 03/04/2016 Due 03/04/2021 Non-Callable	250,000.000	252,057.50 248,550.00	6,250.00 2,552.08	2.48%
Total Fixed Income		\$ 7,583,096.99 \$ 7,544,572.51	157,720.00 37,518.33	2.08%
Cash				
Principal Cash		0.00 0.00	0.00	0.00%
Income Cash		0.00 0.00	0.00	0.00%
Total Cash		\$ 0.00 \$ 0.00	0.00 0.00	0.00%
Total Market Value		\$ 8,049,541.03 \$ 8,011,016.55	164,809.00 38,443.28	2.05%
Total Market Value Plus Accruals		\$ 8,087,984.31		

Income Activity

	Date	Income Cash	Principal Cash
Interest Income			
Bank of The West Advantage Acct Int To 12/31/19	01/02/20		1,070.63
Federal Home Ln Mtg Corp Partn Gold Group #G13107 5.500% Dtd 03/01/2008 Due 07/01/2020 IPD14 Int For December 2019 on 137.53	01/15/20		0.63
Federal Home Ln Mtg Corp Partn Gold Group #G11940 5.500% Dtd 03/01/2006 Due 05/01/2020 IPD14 Int For December 2019 on 194.62	01/15/20		0.89



WBSD - OPERATING RESERVE

Account Number:
Statement Period:

01/01/20 -
01/31/20

Income Activity			
	Date	Income Cash	Principal Cash
Federal Farm Cr Bks Cons Systemwide Bds 1.72% Dtd 07/26/2017 Due 07/26/2021 Non-Callable Int To 01/26/20 on 235,000	01/27/20		2,021.00
Federal Home Ln Mtg Corp 2.00% Dtd 04/26/2017 Due 10/26/2021 Callable Interest At Full Call of	01/27/20		1,200.00
Federal Home Ln Mtg Corp 2.00% Dtd 10/12/2017 Due 10/12/2021 Callable Interest At Full Call of	01/13/20		600.00
Federal Natl Mtg Assn 2.00% Dtd 01/09/2017 Due 01/05/2022 Non-Callable Int To 01/05/20 on 505,000	01/06/20		5,050.00
Federal Home Ln Mtg Corp 2.375% Dtd 01/13/2012 Due 01/13/2022 Non-Callable Int To 01/13/20 on 325,000	01/13/20		3,859.37
Federal Natl Mtg Assn Gtd Passthru CTF Pool #797828 5.000% Dtd 04/01/2005 Due 04/01/2020 IPD24 Int For December 2019 on 1502.77	01/27/20		6.26
Ncua Guaran Nts Tr Ser 2010 R1 Cl I A Fltg Rate Dtd 10/27/2010 Due 10/07/2020 Int To 01/08/20 on 81643.94	01/08/20		161.89
US Treasury Note 2.00% Dtd 07/31/2013 Due 07/31/2020 Int To 01/31/20 on 40,000	01/31/20		400.00
US Treasury Note 2.50% Dtd 01/31/2019 Due 01/31/2021 Int To 01/31/20 on 200,000	01/31/20		2,500.00
Total Interest Income		\$ 0.00	\$ 16,870.67
Purchased Income			
Federal Farm Cr Bks Cons Systemwide Bds 1.64% Dtd 12/11/2019 Due 06/11/2021 Callable Accrued Int To 01/28/20 Paid on Purchase of 100,000	01/28/20		-214.11



WBSD - OPERATING RESERVE

Account Number:
 Statement Period:

01/01/20 -
 01/31/20

Income Activity			
	Date	Income Cash	Principal Cash
Federal Home Ln Mtg Corp 1.65% Dtd 01/27/2020 Due 04/27/2022 Callable Accrued Int To 01/29/20 Paid on Purchase of 100,000	01/29/20		-9.17
Federal Natl Mtg Assn 1.50% Dtd 10/19/2015 Due 11/30/2020 Non-Callable Accrued Int To 01/29/20 Paid on Purchase of 100,000	01/29/20		-245.83
Federal Natl Mtg Assn 1.80% Dtd 10/26/2012 Due 10/26/2021 Callable Accrued Int To 01/03/20 Paid on Purchase of 200,000	01/03/20		-670.00
Indiana Univ Revs Student Fee Bds V Taxable 2.227% Dtd 10/26/2012 Due 08/01/2020 Callable Accrued Int To 01/07/20 Paid on Purchase of 25,000	01/07/20		-239.72
Michigan St GO Ref Bds 2009a Taxable 6.95% Dtd 04/14/2009 Due 11/01/2020 Non-Callable Accrued Int To 01/06/20 Paid on Purchase of 25,000	01/06/20		-313.71
Ncua Guaran Nts Tr Ser 2010 R1 CI I A Fltg Rate Dtd 10/27/2010 Due 10/07/2020 Accrued Int To 01/07/20 Paid on Purchase of 81,643.940	01/07/20		-152.08
New Hampshire Health & Ed Facs Taxable Univ Sys Issue B 2017 B Taxable 2.292% Dtd 12/06/2017 Due 07/01/2021 Non-Callable Accrued Int To 01/07/20 Paid on Purchase of 25,000	01/07/20		-7.96
New York St Dorm Auth St Pers Income Tax Rev Bds 2010c Taxable 4.554% Dtd 03/11/2010 Due 02/15/2021 Callable Accrued Int To 01/07/20 Paid on Purchase of 25,000	01/07/20		-445.91



WBSD - OPERATING RESERVE

Account Number:
Statement Period:

01/01/20 -
01/31/20

Income Activity			
	Date	Income Cash	Principal Cash
US Treasury Note 1.625% Dtd 11/30/2015 Due 11/30/2020 Accrued Int To 01/27/20 Paid on Purchase of 100,000	01/27/20		-257.52
US Treasury Note 0.125% Dtd 04/15/2016 Due 04/15/2021 Treasury Inflation Protection Security Accrued Int To 01/29/20 Paid on Purchase of 97,676.100	01/29/20		-35.36
Total Purchased Income		\$ 0.00	\$ -2,591.37
Total Income		\$ 0.00	\$ 14,279.30

Disbursement Activity			
	Date	Income Cash	Principal Cash
Fees/Expenses			
Monthly Fee To 12/31/19	01/15/20		-1,417.17
Total Fees/Expenses		\$ 0.00	\$ -1,417.17
Total Disbursements		\$ 0.00	\$ -1,417.17

Purchase Activity			
	Date	Income Cash	Principal Cash
Bank of The West Advantage Acct Purchases (6) 01/01/20 To 01/31/20	01/31/20		-274,160.35
Federal Farm Cr Bks Cons Systemwide Bds 1.64% Dtd 12/11/2019 Due 06/11/2021 Callable Purchased 100000 01/27/20 From BOK Financial Securities, Inc. @ 100	01/28/20		-100,000.00
Federal Home Ln Mtg Corp 1.65% Dtd 01/27/2020 Due 04/27/2022 Callable Purchased 100000 01/28/20 From Wells Fargo Securities, LLC @ 99.99	01/29/20		-99,990.00



WBSD - OPERATING RESERVE

Account Number:
 Statement Period:

01/01/20 -
 01/31/20

Purchase Activity			
	Date	Income Cash	Principal Cash
Federal Natl Mtg Assn 1.50% Dtd 10/19/2015 Due 11/30/2020 Non-Callable Purchased 100000 01/28/20 From BNY Mellon/Toronto Dominion Sec @ 99.882	01/29/20		-99,882.00
Federal Natl Mtg Assn 1.80% Dtd 10/26/2012 Due 10/26/2021 Callable Purchased 200000 01/02/20 From Morgan Stanley & Co @ 100	01/03/20		-200,000.00
Indiana Univ Revs Student Fee Bds V Taxable 2.227% Dtd 10/26/2012 Due 08/01/2020 Callable Purchased 25000 01/03/20 From D A Davidson & Co @ 100.32	01/07/20		-25,080.00
Michigan St GO Ref Bds 2009a Taxable 6.95% Dtd 04/14/2009 Due 11/01/2020 Non-Callable Purchased 25000 01/02/20 From Headlands Holdings LLC @ 104.217	01/06/20		-26,054.25
Ncua Guaran Nts Tr Ser 2010 R1 CI I A Fltg Rate Dtd 10/27/2010 Due 10/07/2020 Purchased 81643.940 01/03/20 From D A Davidson & Co @ 100.25	01/07/20		-81,848.05
New Hampshire Health & Ed Facs Taxable Univ Sys Issue B 2017 B Taxable 2.292% Dtd 12/06/2017 Due 07/01/2021 Non-Callable Purchased 25000 01/03/20 From D A Davidson & Co @ 100.635	01/07/20		-25,158.75
New York St Dorm Auth St Pers Income Tax Rev Bds 2010c Taxable 4.554% Dtd 03/11/2010 Due 02/15/2021 Callable Purchased 25000 01/03/20 From D A Davidson & Co @ 102.743	01/07/20		-25,685.75



WBSD - OPERATING RESERVE

Account Number:
 Statement Period:

01/01/20 -
 01/31/20

Purchase Activity			
	Date	Income Cash	Principal Cash
San Francisco Calif City & Cnt Taxable Ref Bds 2019 A Taxable 1.814% Dtd 01/09/2020 Due 11/01/2020 Callable Purchased 50000 01/02/20 From Tmc Bonds LLC @ 100.05	01/09/20		-50,025.00
US Treasury Note 1.625% Dtd 11/30/2015 Due 11/30/2020 Purchased 100000 01/24/20 From Wells Fargo Securities, LLC @ 100.046875	01/27/20		-100,046.88
US Treasury Note 0.125% Dtd 04/15/2016 Due 04/15/2021 Treasury Inflation Protection Security Purchased 97676.100 01/28/20 From Barclays Capital Inc Fixed Inc @ 99.7578125	01/29/20		-97,439.54
Total Purchases		\$ 0.00	\$ -1,205,370.57

Sale Activity			
	Date	Proceeds	Realized Gain/Loss
Bank of The West Advantage Acct Sales (7) 01/01/20 To 01/31/20	01/31/20	829,864.36	
Federal Home Ln Mtg Corp Partn Gold Group #G13107 5.500% Dtd 03/01/2008 Due 07/01/2020 IPD14 Prin Pmt For December 2019	01/15/20	56.39	-2.85
Federal Home Ln Mtg Corp Partn Gold Group #G11940 5.500% Dtd 03/01/2006 Due 05/01/2020 IPD14 Prin Pmt For December 2019	01/15/20	78.02	-4.29
Federal Home Ln Mtg Corp 2.00% Dtd 04/26/2017 Due 10/26/2021 Callable Recd Proceeds on Full Call of 240,000 Par Value	01/27/20	240,000.00	



WBSD - OPERATING RESERVE

Account Number:
 Statement Period:

01/01/20 -
 01/31/20

Sale Activity			
	Date	Proceeds	Realized Gain/Loss
Federal Home Ln Mtg Corp 2.00% Dtd 10/12/2017 Due 10/12/2021 Callable Recd Proceeds on Full Call of 120,000 Par Value	01/13/20	120,000.00	
Federal Natl Mtg Assn Gtd Passthru CTF Pool #797828 5.000% Dtd 04/01/2005 Due 04/01/2020 IPD24 Prin Pmt For December 2019	01/27/20	649.96	-36.15
Ncua Guaran Nts Tr Ser 2010 R1 Cl I A Fltg Rate Dtd 10/27/2010 Due 10/07/2020 Prin Pmt For 01/08/20	01/08/20	1,859.71	-4.65
Total Sales		\$ 1,192,508.44	\$ -47.94

Non-Cash Activity		
	Date	Cost
Federal Farm Cr Bks Cons Systemwide Bds 1.72% Dtd 07/26/2017 Due 07/26/2021 Non-Callable Amortization of Premium	01/24/20	-84.60
Federal Natl Mtg Assn 1.375% Dtd 02/05/2016 Due 02/26/2021 Non-Callable Accretion of Discount	01/31/20	21.38
Federal Natl Mtg Assn 1.25% Dtd 05/16/2016 Due 05/06/2021 Non-Callable Accretion of Discount	01/31/20	43.35
Federal Natl Mtg Assn 1.375% Dtd 10/07/2016 Due 10/07/2021 Non-Callable Accretion of Discount	01/31/20	25.07
Federal Natl Mtg Assn 2.00% Dtd 01/09/2017 Due 01/05/2022 Non-Callable Amortization of Premium	01/03/20	-52.20
Amortization of Premium	01/03/20	-378.35
Accretion of Discount	01/31/20	45.06



WBSD - OPERATING RESERVE

Account Number:
 Statement Period:

01/01/20 -
 01/31/20

Non-Cash Activity		
	Date	Cost
Federal Home Ln Mtg Corp 2.375% Dtd 01/13/2012 Due 01/13/2022 Non-Callable		
Amortization of Premium	01/13/20	-249.30
Amortization of Premium	01/13/20	-822.50
Federal Home Ln Mtg Corp 1.375% Dtd 04/04/2013 Due 05/01/2020 Non-Callable		
Accretion of Discount	01/31/20	9.74
3M Co Fr 2.00% Dtd 06/26/2012 Due 06/26/2022 Non-Callable		
Accretion of Discount	01/31/20	22.27
US Treasury Note 0.125% Dtd 04/15/2016 Due 04/15/2021 Treasury Inflation Protection Security		
Inflationary Int Adjustment 01/30/20	01/30/20	-3.60
US Treasury Note 2.00% Dtd 07/31/2013 Due 07/31/2020		
Accretion of Discount	01/31/20	101.74
US Treasury Note 2.50% Dtd 01/31/2019 Due 01/31/2021		
Amortization of Premium	01/31/20	-168.67
United Technologies Corp Sr Glbl 2.30% Dtd 05/04/2017 Due 05/04/2022 Callable		
Accretion of Discount	01/31/20	243.60
Total Non-Cash Transactions		\$ -1,247.01

SECURITY PRICES CONTAINED IN THIS STATEMENT ARE OBTAINED FROM THE MOST RELIABLE SOURCES AVAILABLE BUT ARE NOT GUARANTEED BY BANK OF THE WEST. QUOTED PRICES MAY NOT EQUAL ACTUAL PRICES BECAUSE OF SECURITY SIZE, MARKET PRICE, TERM AND DEMAND.



Electronic Funds Transfers

Preauthorized Transfers:

You may request an electronic fund transfer (EFT), such as an ACH transfer from or deposit to your account, by contacting your account Administrator. You may also preauthorize periodic EFTs by contacting your account Administrator. If you would like to know whether a preauthorized EFT has occurred, please contact your account Administrator at the phone number listed on the first page of your statement, or call 1-877-232-7321 (TTY 866-827-6167) between the hours of 8:00 A.M. to 5:00 P.M. Pacific Standard Time.

Error Resolution Notice:

If you think a statement or receipt is wrong or if you need more information about an EFT listed on a statement or receipt, telephone us at 1-877-232-7321 (TTY 866-827-6167) between the hours of 8:00 A.M. to 5:00 P.M. Pacific Standard Time, write to us at Bank of the West, 13300 Crossroads Parkway North, City of Industry, CA 91746, or e-mail us at WMGGIFSOperations@bankofthewest.com as soon as possible. We must hear from you no later than 60 days after we sent the FIRST statement on which the problem or error appeared.

1. Tell us your name and account number (if any).
2. Tell us the dollar amount of the suspected error.
3. Describe the error or the transfer you are unsure about, and explain as clearly as you can why you believe it is an error or why you need more information.

If you contact us verbally, we may require that you send us your complaint or question in writing within 10 business days. We will investigate your complaint and will correct any error promptly. If we take more than 10 business days to do this, we will credit your account for the amount you think is in error, so that you will have the use of the money during the time it takes us to complete our investigation.



WBSD - RATE STABILIZATION RESERVE

Account Number:
 Statement Period:

01/01/20 -
 01/31/20

WEST BAY SANITARY DISTRICT
 RATE STABILIZATION RESERVE
 500 LAUREL STREET
 MENLO PARK CA 94025

Fiduciary
 Chuen Ying Lee
 (408) 645-3234
Portfolio
 Michael D. Smith
 (408) 490-2079

Asset Allocation

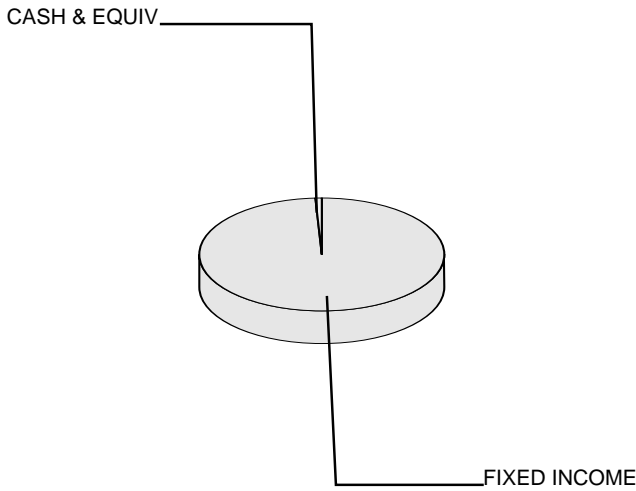

Asset Valuation

Description	Market Value	% of Account
Cash & Equiv	14,551.47	1.1%
Fixed Income	1,359,495.17	98.9%
Total Portfolio	\$ 1,374,046.64	100.0%
Accrued Income	19,480.30	
Total Valuation	\$ 1,393,526.94	

Market Reconciliation

	Current Period	Year To Date
Beginning Market Value	\$ 1,389,906.04	\$ 6,081,980.07
Income		
Interest.....	1,522.49	74,168.67
Purchased Income.....	-92.34	-588.26
Disbursements.....	-242.47	-1,559,621.14
Cash Transfers.....	0.00	-17,700.00
Realized Gains/(Losses).....	0.00	-5,003.35
Change In Accrued Income.....	2,378.92	-24,489.95
Change In Market Appreciation/(Depreciation).....	134.46	16,181.48
Non-Cash Asset Changes.....	-80.16	-3,171,400.58
Ending Market Value	\$ 1,393,526.94	\$ 1,393,526.94



WBSD - RATE STABILIZATION RESERVE

Account Number:
 Statement Period:

01/01/20 -
 01/31/20

Asset Position As of 01/31/20

Asset Description	Units	Market Value Cost	Est. Annual Income Accruals	Current Yield
Cash Equivalents				
Bank of The West Advantage Acct	14,551.470	14,551.47 14,551.47	221.00 43.43	1.52%
Total Cash Equivalents		\$ 14,551.47 \$ 14,551.47	221.00 43.43	1.52%
Fixed Income				
Federal Farm Cr Bks Cons Systemwide Bds 1.90% Dtd 07/19/2017 Due 07/19/2022 Non-Callable	80,000.000	80,894.40 80,194.40	1,520.00 50.66	1.88%
Federal Farm Cr Bks Cons Systemwide Bds 1.90% Dtd 08/03/2017 Due 08/03/2022 Non-Callable	85,000.000	85,957.95 85,135.15	1,615.00 798.52	1.88%
Federal Farm Cr Bks Cons Systemwide Bds 1.64% Dtd 12/11/2019 Due 06/11/2021 Callable	10,000.000	10,000.20 10,000.00	164.00 22.77	1.64%
Federal Home Ln Mtg Corp 1.50% Dtd 09/30/2016 Due 03/30/2021 Callable	90,000.000	90,008.10 90,000.00	1,350.00 453.75	1.50%
Federal Home Ln Mtg Corp 1.60% Dtd 05/15/2017 Due 05/15/2020 Callable	40,000.000	40,002.40 40,000.00	640.00 135.11	1.60%
Federal Natl Mtg Assn 1.875% Dtd 04/10/2017 Due 04/05/2022 Non-Callable	95,000.000	96,050.70 95,200.45	1,781.00 573.95	1.85%
Federal Natl Mtg Assn 1.80% Dtd 10/26/2012 Due 10/26/2021 Callable	20,000.000	20,010.20 20,000.00	360.00 95.00	1.80%
Silicon Vy Clean Wtr Calif Was Rev Bds 5.00% Dtd 11/24/2015 Due 08/01/2020 Non-Callable --- 650,000 Restricted ---	650,000.000	663,858.00 675,010.00	32,500.00 16,250.00	4.90%
US Treasury Note 1.625% Dtd 11/30/2015 Due 11/30/2020	150,000.000	150,097.50 148,264.18	2,437.00 419.56	1.62%
US Treasury Note 0.125% Dtd 04/15/2016 Due 04/15/2021 Treasury Inflation Protection Security	10,852.500	10,828.62 10,826.22	13.00 4.04	0.13%



WBSD - RATE STABILIZATION RESERVE

Account Number:
Statement Period:

01/01/20 -
01/31/20

Asset Position As of 01/31/20

Asset Description	Units	Market Value Cost	Est. Annual Income Accruals	Current Yield
US Treasury Note 2.75% Dtd 09/15/2018 Due 09/15/2021	60,000.000	61,299.60 59,817.19	1,650.00 630.08	2.69%
US Treasury Note 2.50% Dtd 01/31/2019 Due 01/31/2021	50,000.000	50,487.50 50,416.82	1,250.00 3.43	2.48%
Total Fixed Income		\$ 1,359,495.17 \$ 1,364,864.41	45,280.00 19,436.87	3.33%
Cash				
Principal Cash		0.00 0.00	0.00	0.00%
Income Cash		0.00 0.00	0.00	0.00%
Total Cash		\$ 0.00 \$ 0.00	0.00 0.00	0.00%
Total Market Value		\$ 1,374,046.64 \$ 1,379,415.88	45,501.00 19,480.30	3.31%
Total Market Value Plus Accruals		\$ 1,393,526.94		

Income Activity

	Date	Income Cash	Principal Cash
Interest Income			
Bank of The West Advantage Acct Int To 12/31/19	01/02/20		137.49
Federal Farm Cr Bks Cons Systemwide Bds 1.90% Dtd 07/19/2017 Due 07/19/2022 Non-Callable Int To 01/19/20 on 80,000	01/21/20		760.00
US Treasury Note 2.50% Dtd 01/31/2019 Due 01/31/2021 Int To 01/31/20 on 50,000	01/31/20		625.00
Total Interest Income		\$ 0.00	\$ 1,522.49



WBSD - RATE STABILIZATION RESERVE

Account Number:
 Statement Period:

01/01/20 -
 01/31/20

Income Activity			
	Date	Income Cash	Principal Cash
Purchased Income			
Federal Farm Cr Bks Cons Systemwide Bds 1.64% Dtd 12/11/2019 Due 06/11/2021 Callable Accrued Int To 01/28/20 Paid on Purchase of 10,000	01/28/20		-21.41
Federal Natl Mtg Assn 1.80% Dtd 10/26/2012 Due 10/26/2021 Callable Accrued Int To 01/03/20 Paid on Purchase of 20,000	01/03/20		-67.00
US Treasury Note 0.125% Dtd 04/15/2016 Due 04/15/2021 Treasury Inflation Protection Security Accrued Int To 01/29/20 Paid on Purchase of 10,852.900	01/29/20		-3.93
Total Purchased Income		\$ 0.00	\$ -92.34
Total Income		\$ 0.00	\$ 1,430.15

Disbursement Activity			
	Date	Income Cash	Principal Cash
Fees/Expenses			
Monthly Fee To 12/31/19	01/15/20		-242.47
Total Fees/Expenses		\$ 0.00	\$ -242.47
Total Disbursements		\$ 0.00	\$ -242.47



WBSD - RATE STABILIZATION RESERVE

Account Number:
 Statement Period:

01/01/20 -
 01/31/20

Purchase Activity			
	Date	Income Cash	Principal Cash
Bank of The West Advantage Acct Purchases (3) 01/01/20 To 01/31/20	01/31/20		-1,522.49
Federal Farm Cr Bks Cons Systemwide Bds 1.64% Dtd 12/11/2019 Due 06/11/2021 Callable Purchased 10000 01/27/20 From BOK Financial Securities, Inc. @ 100	01/28/20		-10,000.00
Federal Natl Mtg Assn 1.80% Dtd 10/26/2012 Due 10/26/2021 Callable Purchased 20000 01/02/20 From Morgan Stanley & Co @ 100	01/03/20		-20,000.00
US Treasury Note 0.125% Dtd 04/15/2016 Due 04/15/2021 Treasury Inflation Protection Security Purchased 10852.900 01/28/20 From Barclays Capital Inc Fixed Inc @ 99.7578125	01/29/20		-10,826.62
Total Purchases		\$ 0.00	\$ -42,349.11

Sale Activity			
	Date	Proceeds	Realized Gain/Loss
Bank of The West Advantage Acct Sales (4) 01/01/20 To 01/31/20	01/31/20	41,161.43	
Total Sales		\$ 41,161.43	\$ 0.00

Non-Cash Activity		
	Date	Cost
Federal Farm Cr Bks Cons Systemwide Bds 1.90% Dtd 07/19/2017 Due 07/19/2022 Non-Callable Amortization of Premium	01/17/20	-37.60



WBSD - RATE STABILIZATION RESERVE

Account Number:
Statement Period:

01/01/20 -
01/31/20

Non-Cash Activity		
	Date	Cost
US Treasury Note 0.125% Dtd 04/15/2016 Due 04/15/2021 Treasury Inflation Protection Security Inflationary Int Adjustment 01/30/20	01/30/20	-0.40
US Treasury Note 2.50% Dtd 01/31/2019 Due 01/31/2021 Amortization of Premium	01/31/20	-42.16
Total Non-Cash Transactions		\$ -80.16

SECURITY PRICES CONTAINED IN THIS STATEMENT ARE OBTAINED FROM THE MOST RELIABLE SOURCES AVAILABLE BUT ARE NOT GUARANTEED BY BANK OF THE WEST. QUOTED PRICES MAY NOT EQUAL ACTUAL PRICES BECAUSE OF SECURITY SIZE, MARKET PRICE, TERM AND DEMAND.



Electronic Funds Transfers

Preauthorized Transfers:

You may request an electronic fund transfer (EFT), such as an ACH transfer from or deposit to your account, by contacting your account Administrator. You may also preauthorize periodic EFTs by contacting your account Administrator. If you would like to know whether a preauthorized EFT has occurred, please contact your account Administrator at the phone number listed on the first page of your statement, or call 1-877-232-7321 (TTY 866-827-6167) between the hours of 8:00 A.M. to 5:00 P.M. Pacific Standard Time.

Error Resolution Notice:

If you think a statement or receipt is wrong or if you need more information about an EFT listed on a statement or receipt, telephone us at 1-877-232-7321 (TTY 866-827-6167) between the hours of 8:00 A.M. to 5:00 P.M. Pacific Standard Time, write to us at Bank of the West, 13300 Crossroads Parkway North, City of Industry, CA 91746, or e-mail us at WMGGIFSOperations@bankofthewest.com as soon as possible. We must hear from you no later than 60 days after we sent the FIRST statement on which the problem or error appeared.

1. Tell us your name and account number (if any).
2. Tell us the dollar amount of the suspected error.
3. Describe the error or the transfer you are unsure about, and explain as clearly as you can why you believe it is an error or why you need more information.

If you contact us verbally, we may require that you send us your complaint or question in writing within 10 business days. We will investigate your complaint and will correct any error promptly. If we take more than 10 business days to do this, we will credit your account for the amount you think is in error, so that you will have the use of the money during the time it takes us to complete our investigation.



WBSD - RECYCLED WATER CASH FLOW

Account Number:
 Statement Period:

01/01/20 -
 01/31/20

WEST BAY SANITARY DISTRICT
 RECYCLED WATER CASH FLOW
 500 LAUREL STREET
 MENLO PARK CA 94025

Fiduciary
 Chuen Ying Lee
 (408) 645-3234
Portfolio
 Michael D. Smith
 (408) 490-2079

Asset Allocation

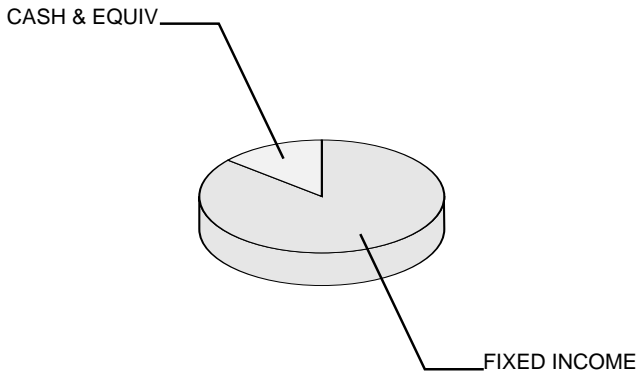

Asset Valuation

Description	Market Value	% of Account
Cash & Equiv	31,937.16	14.2%
Fixed Income	193,427.64	85.8%
Total Portfolio	\$ 225,364.80	100.0%
Accrued Income	468.95	
Total Valuation	\$ 225,833.75	

Market Reconciliation

	Current Period	Year To Date
Beginning Market Value	\$ 225,478.97	\$ 223,524.55
Income		
Interest.....	908.12	3,149.47
Purchased Income.....	-233.39	-729.31
Disbursements.....	-39.68	-266.71
Realized Gains/(Losses).....	0.00	0.00
Change In Accrued Income.....	-337.26	-62.06
Change In Market Appreciation/(Depreciation).....	100.55	261.37
Non-Cash Asset Changes.....	-43.56	-43.56
Ending Market Value	\$ 225,833.75	\$ 225,833.75



WBSD - RECYCLED WATER CASH FLOW

Account Number:
Statement Period:

01/01/20 -
01/31/20

Asset Position As of 01/31/20

Asset Description	Units	Market Value Cost	Est. Annual Income Accruals	Current Yield
Cash Equivalents				
Bank of The West Advantage Acct	31,937.160	31,937.16 31,937.16	485.00 142.58	1.52%
Total Cash Equivalents		\$ 31,937.16 \$ 31,937.16	485.00 142.58	1.52%
Fixed Income				
Federal Farm Cr Bks Cons Systemwide Bds 1.64% Dtd 12/11/2019 Due 06/11/2021 Callable	40,000.000	40,000.80 40,000.00	656.00 91.10	1.64%
Federal Natl Mtg Assn 1.80% Dtd 10/26/2012 Due 10/26/2021 Callable	40,000.000	40,020.40 40,000.00	720.00 190.00	1.80%
San Francisco Calif City & Cnt Taxable Ref Bds 2019 A Taxable 1.814% Dtd 01/09/2020 Due 11/01/2020 Callable	25,000.000	25,018.75 25,012.50	453.00 27.71	1.81%
US Treasury Note 0.125% Dtd 04/15/2016 Due 04/15/2021 Treasury Inflation Protection Security	37,983.750	37,900.19 37,891.75	47.00 14.13	0.13%
US Treasury Note 2.50% Dtd 01/31/2019 Due 01/31/2021	50,000.000	50,487.50 50,416.82	1,250.00 3.43	2.48%
Total Fixed Income		\$ 193,427.64 \$ 193,321.07	3,126.00 326.37	1.62%
Cash				
Principal Cash		0.00 0.00	0.00	0.00%
Income Cash		0.00 0.00	0.00	0.00%
Total Cash		\$ 0.00 \$ 0.00	0.00 0.00	0.00%
Total Market Value		\$ 225,364.80 \$ 225,258.23	3,611.00 468.95	1.60%
Total Market Value Plus Accruals		\$ 225,833.75		



WBSD - RECYCLED WATER CASH FLOW

Account Number:
 Statement Period:

01/01/20 -
 01/31/20

Income Activity			
	Date	Income Cash	Principal Cash
Interest Income			
Bank of The West Advantage Acct Int To 12/31/19	01/02/20		283.12
US Treasury Note 2.50% Dtd 01/31/2019 Due 01/31/2021 Int To 01/31/20 on 50,000	01/31/20		625.00
Total Interest Income		\$ 0.00	\$ 908.12
Purchased Income			
Federal Farm Cr Bks Cons Systemwide Bds 1.64% Dtd 12/11/2019 Due 06/11/2021 Callable Accrued Int To 01/28/20 Paid on Purchase of 40,000	01/28/20		-85.64
Federal Natl Mtg Assn 1.80% Dtd 10/26/2012 Due 10/26/2021 Callable Accrued Int To 01/03/20 Paid on Purchase of 40,000	01/03/20		-134.00
US Treasury Note 0.125% Dtd 04/15/2016 Due 04/15/2021 Treasury Inflation Protection Security Accrued Int To 01/29/20 Paid on Purchase of 37,985.150	01/29/20		-13.75
Total Purchased Income		\$ 0.00	\$ -233.39
Total Income		\$ 0.00	\$ 674.73

Disbursement Activity			
	Date	Income Cash	Principal Cash
Fees/Expenses			
Monthly Fee To 12/31/19	01/15/20		-39.68
Total Fees/Expenses		\$ 0.00	\$ -39.68
Total Disbursements		\$ 0.00	\$ -39.68



WBSD - RECYCLED WATER CASH FLOW

Account Number:
 Statement Period:

01/01/20 -
 01/31/20

Purchase Activity			
	Date	Income Cash	Principal Cash
Bank of The West Advantage Acct Purchases (2) 01/01/20 To 01/31/20	01/31/20		-908.12
Federal Farm Cr Bks Cons Systemwide Bds 1.64% Dtd 12/11/2019 Due 06/11/2021 Callable Purchased 40000 01/27/20 From BOK Financial Securities, Inc. @ 100	01/28/20		-40,000.00
Federal Natl Mtg Assn 1.80% Dtd 10/26/2012 Due 10/26/2021 Callable Purchased 40000 01/02/20 From Morgan Stanley & Co @ 100	01/03/20		-40,000.00
San Francisco Calif City & Cnt Taxable Ref Bds 2019 A Taxable 1.814% Dtd 01/09/2020 Due 11/01/2020 Callable Purchased 25000 01/02/20 From Tmc Bonds LLC @ 100.05	01/09/20		-25,012.50
US Treasury Note 0.125% Dtd 04/15/2016 Due 04/15/2021 Treasury Inflation Protection Security Purchased 37985.150 01/28/20 From Barclays Capital Inc Fixed Inc @ 99.7578125	01/29/20		-37,893.15
Total Purchases		\$ 0.00	\$ -143,813.77

Sale Activity			
	Date	Proceeds	Realized Gain/Loss
Bank of The West Advantage Acct Sales (5) 01/01/20 To 01/31/20	01/31/20	143,178.72	
Total Sales		\$ 143,178.72	\$ 0.00



WBSD - RECYCLED WATER CASH FLOW

Account Number:
Statement Period:

01/01/20 -
01/31/20

Non-Cash Activity		
	Date	Cost
US Treasury Note 0.125% Dtd 04/15/2016 Due 04/15/2021 Treasury Inflation Protection Security Inflationary Int Adjustment 01/30/20	01/30/20	-1.40
US Treasury Note 2.50% Dtd 01/31/2019 Due 01/31/2021 Amortization of Premium	01/31/20	-42.16
Total Non-Cash Transactions		\$ -43.56

SECURITY PRICES CONTAINED IN THIS STATEMENT ARE OBTAINED FROM THE MOST RELIABLE SOURCES AVAILABLE BUT ARE NOT GUARANTEED BY BANK OF THE WEST. QUOTED PRICES MAY NOT EQUAL ACTUAL PRICES BECAUSE OF SECURITY SIZE, MARKET PRICE, TERM AND DEMAND.



Electronic Funds Transfers

Preauthorized Transfers:

You may request an electronic fund transfer (EFT), such as an ACH transfer from or deposit to your account, by contacting your account Administrator. You may also preauthorize periodic EFTs by contacting your account Administrator. If you would like to know whether a preauthorized EFT has occurred, please contact your account Administrator at the phone number listed on the first page of your statement, or call 1-877-232-7321 (TTY 866-827-6167) between the hours of 8:00 A.M. to 5:00 P.M. Pacific Standard Time.

Error Resolution Notice:

If you think a statement or receipt is wrong or if you need more information about an EFT listed on a statement or receipt, telephone us at 1-877-232-7321 (TTY 866-827-6167) between the hours of 8:00 A.M. to 5:00 P.M. Pacific Standard Time, write to us at Bank of the West, 13300 Crossroads Parkway North, City of Industry, CA 91746, or e-mail us at WMGGIFSOoperations@bankofthewest.com as soon as possible. We must hear from you no later than 60 days after we sent the FIRST statement on which the problem or error appeared.

1. Tell us your name and account number (if any).
2. Tell us the dollar amount of the suspected error.
3. Describe the error or the transfer you are unsure about, and explain as clearly as you can why you believe it is an error or why you need more information.

If you contact us verbally, we may require that you send us your complaint or question in writing within 10 business days. We will investigate your complaint and will correct any error promptly. If we take more than 10 business days to do this, we will credit your account for the amount you think is in error, so that you will have the use of the money during the time it takes us to complete our investigation.



WBSD - RECYCLED WATER SRF RESERVE

Account Number:
 Statement Period:

01/01/20 -
 01/31/20

WEST BAY SANITARY DISTRICT
 RECYCLED WATER SRF RESERVE
 500 LAUREL STREET
 MENLO PARK CA 94025

Fiduciary
 Chuen Ying Lee
 (408) 645-3234
Portfolio
 Michael D. Smith
 (408) 490-2079

Asset Allocation

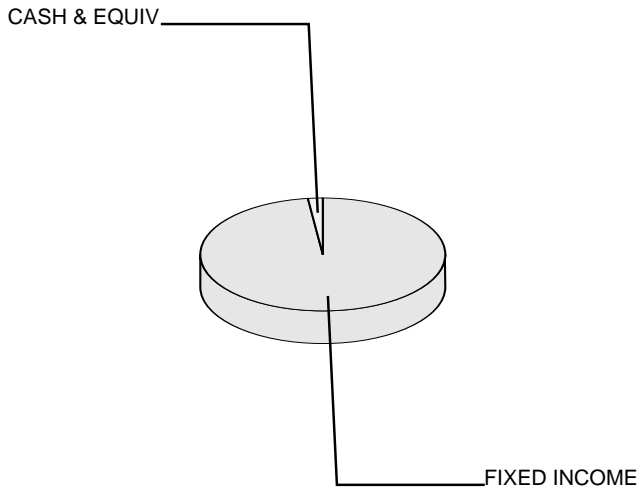

Asset Valuation

Description	Market Value	% of Account
Cash & Equiv	20,269.04	2.4%
Fixed Income	822,154.12	97.6%
Total Portfolio	\$ 842,423.16	100.0%
Accrued Income	6,116.50	
Total Valuation	\$ 848,539.66	

Market Reconciliation

	Current Period	Year To Date
Beginning Market Value	\$ 847,229.27	\$ 838,864.78
Income		
Interest.....	842.78	11,765.31
Purchased Income.....	-184.68	-680.61
Disbursements.....	-148.77	-998.63
Realized Gains/(Losses).....	0.00	1,658.63
Change In Accrued Income.....	1,106.77	1,194.73
Change In Market Appreciation/(Depreciation).....	-334.01	-3,919.79
Non-Cash Asset Changes.....	28.30	655.24
Ending Market Value	\$ 848,539.66	\$ 848,539.66



WBSD - RECYCLED WATER SRF RESERVE

Account Number:
 Statement Period:

01/01/20 -
 01/31/20

Asset Position As of 01/31/20

Asset Description	Units	Market Value Cost	Est. Annual Income Accruals	Current Yield
Cash Equivalents				
Bank of The West Advantage Acct	20,269.040	20,269.04 20,269.04	308.00 85.63	1.52%
Total Cash Equivalents		\$ 20,269.04 \$ 20,269.04	308.00 85.63	1.52%
Fixed Income				
Federal Farm Cr Bks Cons Systemwide Bds 1.64% Dtd 12/11/2019 Due 06/11/2021 Callable	20,000.000	20,000.40 20,000.00	328.00 45.55	1.64%
Federal Farm Cr Bks Cons Systemwide Bds 3.65% Dtd 12/21/2010 Due 12/21/2020 Non-Callable	96,000.000	97,787.52 97,032.00	3,504.00 389.33	3.58%
Federal Natl Mtg Assn 1.80% Dtd 10/26/2012 Due 10/26/2021 Callable	40,000.000	40,020.40 40,000.00	720.00 190.00	1.80%
Federal Natl Mtg Assn 1.55% Dtd 10/28/2016 Due 10/28/2021 Callable	80,000.000	80,014.40 78,507.77	1,240.00 320.33	1.55%
San Francisco Calif City & Cnt Taxable Ref Bds 2019 A Taxable 1.814% Dtd 01/09/2020 Due 11/01/2020 Callable	25,000.000	25,018.75 25,012.50	453.00 27.71	1.81%
US Treasury Note 1.375% Dtd 04/30/2015 Due 04/30/2020	140,000.000	139,916.00 139,289.06	1,925.00 491.82	1.38%
US Treasury Note 3.625% Dtd 02/15/2010 Due 02/15/2020	186,000.000	186,120.90 187,434.12	6,742.00 3,114.74	3.62%
US Treasury Note 0.125% Dtd 04/15/2016 Due 04/15/2021 Treasury Inflation Protection Security	21,705.000	21,657.25 21,652.43	27.00 8.08	0.13%
US Treasury Note 2.00% Dtd 09/30/2013 Due 09/30/2020	20,000.000	20,055.80 19,916.13	400.00 135.51	1.99%
US Treasury Note 2.75% Dtd 09/30/2018 Due 09/30/2020	140,000.000	141,075.20 140,536.49	3,850.00 1,304.37	2.73%
US Treasury Note 2.50% Dtd 01/31/2019 Due 01/31/2021	50,000.000	50,487.50 50,416.82	1,250.00 3.43	2.48%



WBSD - RECYCLED WATER SRF RESERVE

Account Number:
 Statement Period:

01/01/20 -
 01/31/20

Asset Position As of 01/31/20

Asset Description	Units	Market Value Cost	Est. Annual Income Accruals	Current Yield
Total Fixed Income		\$ 822,154.12 \$ 819,797.32	20,439.00 6,030.87	2.49%
Cash				
Principal Cash		0.00 0.00	0.00	0.00%
Income Cash		0.00 0.00	0.00	0.00%
Total Cash		\$ 0.00 \$ 0.00	0.00 0.00	0.00%
Total Market Value		\$ 842,423.16 \$ 840,066.36	20,747.00 6,116.50	2.46%
Total Market Value Plus Accruals		\$ 848,539.66		

Income Activity

	Date	Income Cash	Principal Cash
Interest Income			
Bank of The West Advantage Acct Int To 12/31/19	01/02/20		217.78
US Treasury Note 2.50% Dtd 01/31/2019 Due 01/31/2021 Int To 01/31/20 on 50,000	01/31/20		625.00
Total Interest Income		\$ 0.00	\$ 842.78
Purchased Income			
Federal Farm Cr Bks Cons Systemwide Bds 1.64% Dtd 12/11/2019 Due 06/11/2021 Callable Accrued Int To 01/28/20 Paid on Purchase of 20,000	01/28/20		-42.82
Federal Natl Mtg Assn 1.80% Dtd 10/26/2012 Due 10/26/2021 Callable Accrued Int To 01/03/20 Paid on Purchase of 40,000	01/03/20		-134.00



WBSD - RECYCLED WATER SRF RESERVE

Account Number:
 Statement Period:

01/01/20 -
 01/31/20

Income Activity			
	Date	Income Cash	Principal Cash
US Treasury Note 0.125% Dtd 04/15/2016 Due 04/15/2021 Treasury Inflation Protection Security Accrued Int To 01/29/20 Paid on Purchase of 21,705.800	01/29/20		-7.86
Total Purchased Income		\$ 0.00	\$ -184.68
Total Income		\$ 0.00	\$ 658.10

Disbursement Activity			
	Date	Income Cash	Principal Cash
Fees/Expenses			
Monthly Fee To 12/31/19	01/15/20		-148.77
Total Fees/Expenses		\$ 0.00	\$ -148.77
Total Disbursements		\$ 0.00	\$ -148.77

Purchase Activity			
	Date	Income Cash	Principal Cash
Bank of The West Advantage Acct Purchases (2) 01/01/20 To 01/31/20	01/31/20		-842.78
Federal Farm Cr Bks Cons Systemwide Bds 1.64% Dtd 12/11/2019 Due 06/11/2021 Callable Purchased 20000 01/27/20 From BOK Financial Securities, Inc. @ 100	01/28/20		-20,000.00
Federal Natl Mtg Assn 1.80% Dtd 10/26/2012 Due 10/26/2021 Callable Purchased 40000 01/02/20 From Morgan Stanley & Co @ 100	01/03/20		-40,000.00



WBSD - RECYCLED WATER SRF RESERVE

Account Number:
 Statement Period:

01/01/20 -
 01/31/20

Purchase Activity			
	Date	Income Cash	Principal Cash
San Francisco Calif City & Cnt Taxable Ref Bds 2019 A Taxable 1.814% Dtd 01/09/2020 Due 11/01/2020 Callable Purchased 25000 01/02/20 From Tmc Bonds LLC @ 100.05	01/09/20		-25,012.50
US Treasury Note 0.125% Dtd 04/15/2016 Due 04/15/2021 Treasury Inflation Protection Security Purchased 21705.800 01/28/20 From Barclays Capital Inc Fixed Inc @ 99.7578125	01/29/20		-21,653.23
Total Purchases		\$ 0.00	\$ -107,508.51

Sale Activity			
	Date	Proceeds	Realized Gain/Loss
Bank of The West Advantage Acct Sales (5) 01/01/20 To 01/31/20	01/31/20	106,999.18	
Total Sales		\$ 106,999.18	\$ 0.00

Non-Cash Activity		
	Date	Cost
Federal Natl Mtg Assn 1.55% Dtd 10/28/2016 Due 10/28/2021 Callable Accretion of Discount	01/31/20	71.27
US Treasury Note 0.125% Dtd 04/15/2016 Due 04/15/2021 Treasury Inflation Protection Security Inflationary Int Adjustment 01/30/20	01/30/20	-0.80
US Treasury Note 2.50% Dtd 01/31/2019 Due 01/31/2021 Amortization of Premium	01/31/20	-42.17
Total Non-Cash Transactions		\$ 28.30



BANK OF THE WEST
BNP PARIBAS
WEALTH MANAGEMENT

WBSD - RECYCLED WATER SRF RESERVE

Account Number:
Statement Period:

01/01/20 -
01/31/20

SECURITY PRICES CONTAINED IN THIS STATEMENT ARE OBTAINED FROM THE MOST RELIABLE SOURCES AVAILABLE BUT ARE NOT GUARANTEED BY BANK OF THE WEST. QUOTED PRICES MAY NOT EQUAL ACTUAL PRICES BECAUSE OF SECURITY SIZE, MARKET PRICE, TERM AND DEMAND.



Electronic Funds Transfers

Preauthorized Transfers:

You may request an electronic fund transfer (EFT), such as an ACH transfer from or deposit to your account, by contacting your account Administrator. You may also preauthorize periodic EFTs by contacting your account Administrator. If you would like to know whether a preauthorized EFT has occurred, please contact your account Administrator at the phone number listed on the first page of your statement, or call 1-877-232-7321 (TTY 866-827-6167) between the hours of 8:00 A.M. to 5:00 P.M. Pacific Standard Time.

Error Resolution Notice:

If you think a statement or receipt is wrong or if you need more information about an EFT listed on a statement or receipt, telephone us at 1-877-232-7321 (TTY 866-827-6167) between the hours of 8:00 A.M. to 5:00 P.M. Pacific Standard Time, write to us at Bank of the West, 13300 Crossroads Parkway North, City of Industry, CA 91746, or e-mail us at WMGGIFSOoperations@bankofthewest.com as soon as possible. We must hear from you no later than 60 days after we sent the FIRST statement on which the problem or error appeared.

1. Tell us your name and account number (if any).
2. Tell us the dollar amount of the suspected error.
3. Describe the error or the transfer you are unsure about, and explain as clearly as you can why you believe it is an error or why you need more information.

If you contact us verbally, we may require that you send us your complaint or question in writing within 10 business days. We will investigate your complaint and will correct any error promptly. If we take more than 10 business days to do this, we will credit your account for the amount you think is in error, so that you will have the use of the money during the time it takes us to complete our investigation.



WEST BAY SANITARY DISTRICT AGENDA ITEM 4D

To: *Board of Directors*

From: *Bill Kitajima, Projects & IT Manager*
Jonathan Werness, Engineering Technician

Subject: *Consideration of a Resolution of Intention to Annex Certain Territory (20 Navajo Pl) to the West Bay Sanitary District On-Site Wastewater Disposal Zone and to Establish the Date and Time of Public Hearing*

Background

This property will utilize a Grinder pump system; consequently this property must be annexed into the District's On-Site Wastewater Disposal Zone. The proponent shall be required to install a force main extension on Navajo Place that will eventually connect to the existing force main along Meadowood Drive.

Notice of the Public Hearing is required in accordance with the Government Code and during the notice period, staff shall seek written approval for the proposed annexation from all affected agencies.

Analysis

During the notice period staff shall work with the proponent to obtain design, easement and other approvals, which shall be presented to the Board when the Class 3 Permit is issued.

Fiscal Impact

None.

Recommendation

The Projects and IT Manager recommends that the District Board adopt the attached Resolution of Intention to Annex Certain Territory to the West Bay Sanitary District On-Site Wastewater Disposal Zone and request April 22, 2020 as the date of the public hearing.

Attachments: Resolution, Exhibit A, Exhibit B

RESOLUTION NO. _____(2020)

**RESOLUTION OF INTENTION TO ANNEX CERTAIN TERRITORY TO THE WEST BAY
SANITARY DISTRICT ON-SITE WASTEWATER DISPOSAL ZONE**

Lands of Sick

The District Board of West Bay Sanitary District finds and determines as follows:

A. This Resolution of Intention is adopted pursuant to the District's "Zone Master Annexation Resolution" ("ZOMAR"), which was adopted by the District Board August 12, 1996. The provisions of ZOMAR are incorporated by reference into this Resolution of Intention.

B. The District has received an application to annex a parcel of real property (the "Parcel") to the District's On-Site Wastewater Disposal Zone (the "Zone"). The Parcel is described in Exhibit "A" attached to this Resolution of Intention and the description contained in the Exhibits are incorporated by reference. The name and address of the applicants and the number, type, volume and location of on-site wastewater disposal systems which are proposed to operate on the parcels to be annexed are described in Exhibit "B" attached to this Resolution of Intention and the information contained in the Exhibit are incorporated by reference.

C. The applicants have demonstrated to the satisfaction of the District Board that the Parcel constitutes "real property" for the purposes of Section 2(b) of ZOMAR in that:

All of the conditions described in Subsections i., ii., iii., iv. and v. of ZOMAR Section 2(b) are satisfied; or

Other conditions exist which demonstrate that the Parcel will benefit directly or indirectly from the activities of the Zone. If applicable, those conditions are also set forth in Exhibit "B" and are incorporated by reference.

D. All of the conditions and requirements of ZOMAR Sections 2(a), 2(c), 2(d) and 2(e) have been fully satisfied.

In consideration of the foregoing findings and determinations,

IT IS RESOLVED by the District Board as follows:

1. It is the intention of the District Board to annex the Parcel to the Zone pursuant to the provisions of ZOMAR and applicable provisions of law.
2. In conjunction with a meeting of the District Board to be duly and regularly called and conducted, the Board will conduct a Public Hearing for the purpose of considering all matters pertaining to this Resolution of Intention.

The time, date and place of the Public Hearing are:

Date: April 22, 2020
Time: 7:00 PM
Place: West Bay Sanitary District Offices
500 Laurel Street
Menlo Park, CA 94025

At the Public Hearing, all interested persons will be heard.

3. This Resolution of Intention shall be published and copies shall be delivered to the persons and entities as specified in ZOMAR Section 2(e)(i.).
4. A true copy of this Resolution of Intention shall promptly be filed for record in the office of the County Recorder of the County of San Mateo.
5. The District Manager shall cause the matters set forth in Sections 3 and 4 of this Resolution of Intention to be completed as directed.

Passed and adopted by the District Board of the West Bay Sanitary District at a regular meeting thereof held on the 26th day of February, 2020 by the following vote:

AYES:

NOES:

ABSTAIN:

ABSENT:

President of the District Board of the
West Bay Sanitary District of San Mateo
County, State of California

Attest:

Secretary of the District Board of the
West Bay Sanitary District of San Mateo
County, State of California

ANNEXATION TO WEST BAY SANITARY DISTRICT
GEOGRAPHIC DESCRIPTION

All that certain real property situate in the Town of Portola Valley, County of San Mateo, State of California, being Lot 30 in Block 1 along with Navajo Place, all as shown on that certain map entitled "TRACT NO. 774 ARROWHEAD MEADOWS UNIT NO. 4, BEING A PORTION OF THE RANCHO EL CORTE MADERA" filed on March 17, 1959 in Volume 50 of Maps at Pages 45-48, Records of the County of San Mateo, State of California, and being more particularly described as follows:

Beginning at the centerline intersection of Meadowood Drive and Navajo Place;

Thence (1) South 73°45'00" E, 25.00 feet to the intersection of the centerline of Navajo Place and the easterly line of Meadowood Drive and the TRUE POINT OF BEGINNING of this description:

Thence (2) along said easterly line of Meadowood Drive, North 16°15'00" East, 45.00 feet;

Thence leaving said easterly line, (3) southeasterly on the arc of a curve concave northeasterly, the center of which bears South 73°45'00" East, having a radius of 20.00 feet, a chord length of 28.28 feet, a central angle of 90°00'00" and length of 31.42 feet;

Thence (4) South 73°45'00" East, 305.31 feet;

Thence (5) on the arc of a tangent curve concave northerly, having a radius of 20.00 feet, a chord length of 14.14 feet, a central angle of 41°24'35" and length of 14.45 feet;

Thence (6) on the arc of a reverse curve concave southwesterly, having a radius of 40.00 feet, a chord length of 79.47 feet, a central angle of 193°09'35" and length of 134.85 feet;

Thence (7) South 31°58'11" East, 297.09 feet;

Thence (8) North 89°00'00" West, 60.00 feet;

Thence (9) North 78°30'00" West, 260.00 feet;

Thence (10) North 24°47'01" East, 248.24 feet;

Thence (11) North 73°45'00" West, 305.31 feet;

APPROVED
SAN MATEO LOCAL AGENCY
FORMATION COMMISSION
455 COUNTY CENTER
REDWOOD CITY, CA 94063

EXHIBIT A PAGE 1 OF 3

Thence (12) on the arc of a tangent curve concave southeasterly, having a radius of 20.00 feet, a chord length of 28.28 feet, a central angle of 90°00'00" and length of 31.42 feet;

Thence (13) North 16°15'00" East, 45.00 feet to the TRUE POINT OF BEGINNING.

Containing 1.51 acres, more or less.

For assessment purposes only. This description of land is not a legal property description as defined in the Subdivision Map Act and may not be used as the basis for an offer for sale of the land described.



APPROVED
SAN MATEO LOCAL AGENCY
FORMATION COMMISSION
455 COUNTY CENTER
REDWOOD CITY, CA 94063

EXHIBIT A PAGE 2 OF 3

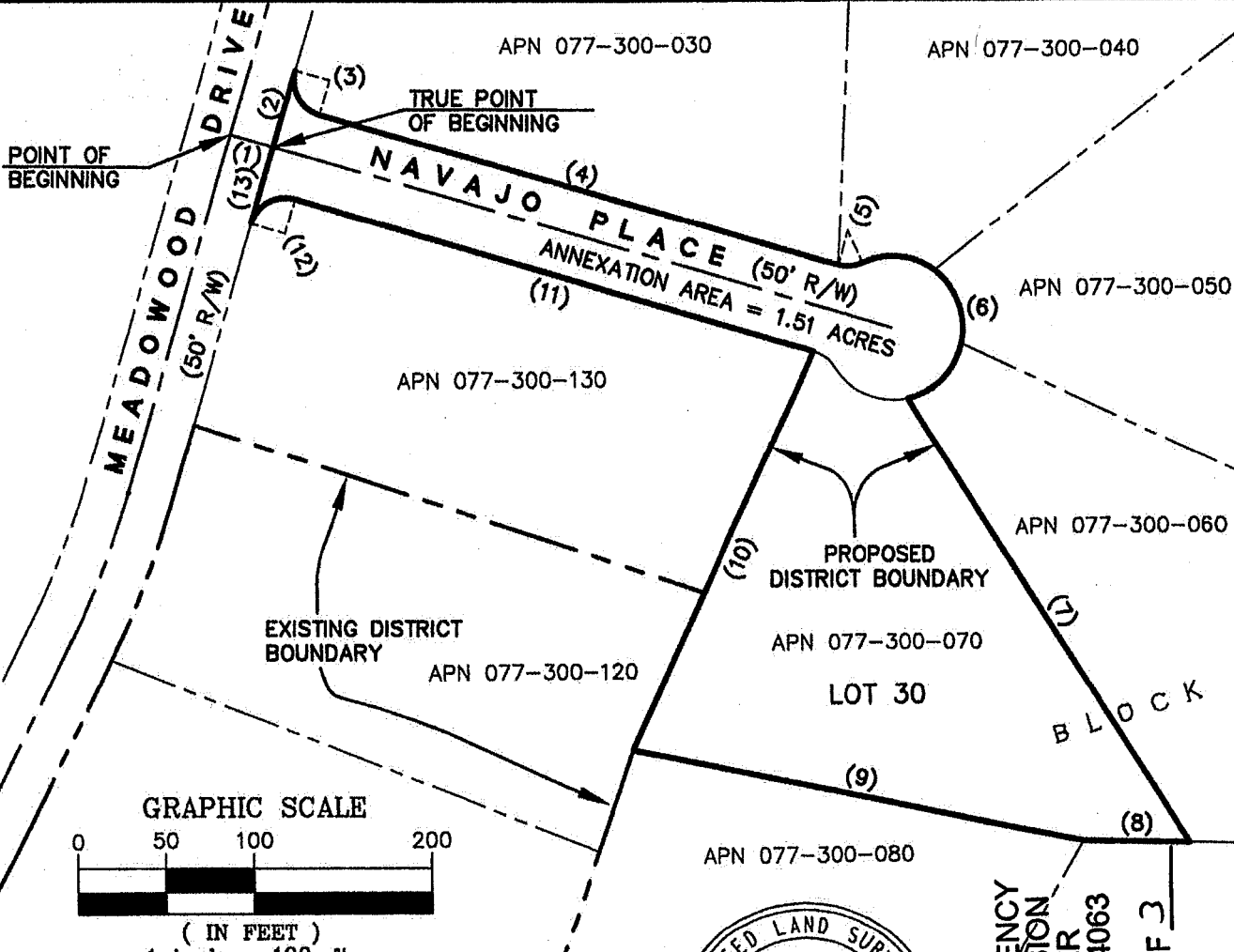

DISCLAIMER:

FOR ASSESSMENT PURPOSES ONLY. THIS DESCRIPTION OF LAND IS NOT A LEGAL PROPERTY DESCRIPTION AS DEFINED IN THE SUBDIVISION MAP ACT AND MAY NOT BE USED AS THE BASIS FOR AN OFFER FOR SALE OF THE LAND DESCRIBED.

LICENSED LAND SURVEYOR
WAYNE HAAS
No. LS 7701
Exp. 12-31-20
STATE OF CALIFORNIA

Wayne Haas

APPROVED LOCAL AGENCY
SAN MATEO LOCAL AGENCY
FORMATION COMMISSION
455 COUNTY CENTER
REDWOOD CITY, CA 94063

EXHIBIT A PAGE 3 OF 3

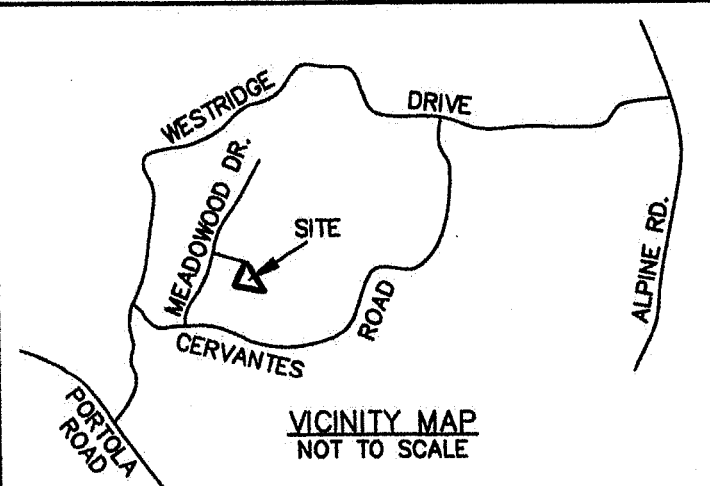

11-13-19

COURSE					
1	S 73°45'00"	E	25.00'		
2	N 16°15'00"	E	45.00'		
3	R = 20.00'	CH = 28.28'		Δ = 90°00'00"	L = 31.42'
4	S 73°45'00"	E	305.31'		
5	R = 20.00'	CH = 14.14'		Δ = 41°24'35"	L = 17.45'
6	R = 40.00'	CH = 79.47'		Δ = 193°09'35"	L = 134.85'
7	S 31°58'11"	E	297.09'		
8	N 89°00'00"	W	60.00'		
9	N 78°30'00"	W	260.00'		
10	N 24°47'01"	E	248.24'		
11	N 73°45'00"	W	305.31'		
12	R = 20.00'	CH = 28.28'		Δ = 90°00'00"	L = 31.42'
13	N 16°15'00"	E	45.00'		

B & H SURVEYING, INC. 901 WALTERMIRE ST., BELMONT, CA 94002 (650) 637-1590

TITLE: ANNEXATION OF A PORTION OF THE RANCHO EL CORTE MADERA
TOWN: PORTOLA VALLEY COUNTY: SAN MATEO COUNTY CALIFORNIA

SURV:	SCALE: 1" = 100'	FOR:	JOB NO. 7441-19
PLAT:	DATE: OCTOBER, 2019		DWG NO. 7441-ANNEX



WEST BAY SANITARY DISTRICT
EXHIBIT "B"
SITE LOCATION
20 NAVAJO PLACE
PORTOLA VALLEY, CA
GRINDER PUMP SYSTEM

(1) Grinder Pump System
200 Gallons Per Day (GPD)
APN: 077-300-070
Lands of Sick
20 Navajo Place
Portola Valley, CA
Location of System: Front of property

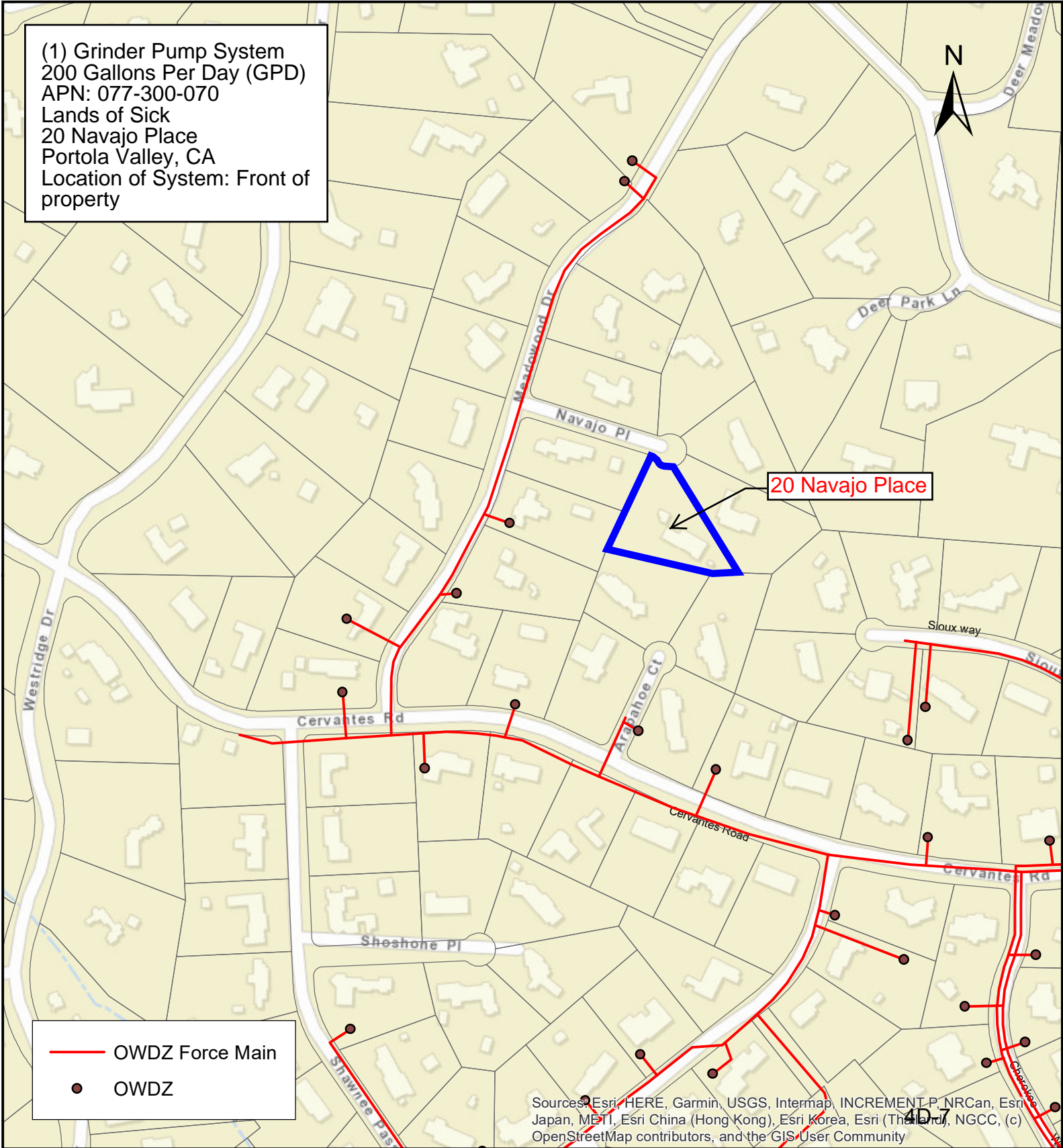

Sources: Esri, HERE, Garmin, USGS, Intermap, INCREMENT P, NRCan, Esri Japan, METI, Esri China (Hong Kong), Esri Korea, Esri (The Netherlands), NGCC, (c) OpenStreetMap contributors, and the GIS User Community

**RESOLUTION OF THE LOCAL AGENCY FORMATION COMMISSION
OF THE COUNTY OF SAN MATEO
MAKING DETERMINATIONS, APPROVING LAFCO FILE 19-09 -
ANNEXATION OF 20 NAVAJO PLACE, PORTOLA VALLEY (APN 077-300-070)
TO THE WEST BAY SANITARY DISTRICT,
WAIVING CONDUCTING AUTHORITY PROCEEDINGS
AND ORDERING SAID ANNEXATION
AND SUBSEQUENT ANNEXATION TO THE 'ZONE'**

RESOLVED, by the Local Agency Formation Commission of the County of San Mateo, State of California, that

WHEREAS, a proposal for the annexation of certain territory to the West Bay Sanitary District in the County of San Mateo was heretofore filed with the Executive Officer of this Local Agency Formation Commission pursuant to Title 5, Division 3, commencing with Section 56000 of the Government Code; and

WHEREAS, the Executive Officer has reviewed the proposal and prepared a report, including the recommendations thereon, the proposal and report having been presented to and considered by this Commission; and

WHEREAS, it appears to the satisfaction of this Commission that all owners of the land included in the proposal consent to the proceeding; and

WHEREAS, a public hearing by this Commission was held on the proposal and at the hearing this Commission heard and received all oral and written protests, objections and evidence which were made, presented or filed, and all persons present were given an opportunity to hear and be heard with respect to the proposal and the Executive Officer's report; and

WHEREAS, the landowners and District have requested that the Commission waive conducting authority proceedings pursuant to government code Section 56837(c); and

WHEREAS, the proposal is categorically exempt from the environmental review requirements of the



LOCAL AGENCY FORMATION COMMISSION

455 COUNTY CENTER, 2ND FLOOR • REDWOOD CITY, CA 94063-1663 • PHONE (650) 363-4224 • FAX (650) 363-4849

CERTIFICATE OF COMPLETION

Pursuant to Government Code Section 57200, this Certificate is issued by the Executive Officer of the Local Agency Formation Commission of San Mateo County, California.

1. The short-form designation, as determined by LAFCo, is Annexation of 20 Navajo Place, Portola Valley (APN 077-300-070) to the West Bay Sanitary District.
2. The name of each district or city involved in this change of organization or reorganization and the kind or type of change of organization ordered for each city or district are as follows:

<u>City or District</u>	<u>Type of Change of Organization</u>
-------------------------	---------------------------------------

West Bay Sanitary District	Annexation
----------------------------	------------

3. The above-listed cities and/or districts are located within the following counties: San Mateo County only.
4. A description of the boundaries of the above-cited change of organization or reorganization is shown on the attached map, marked Exhibit A and by reference incorporated herein.
5. The territory involved in this change of organization or reorganization is uninhabited.
6. This change of organization has been approved subject to the following terms and conditions, if any: None.
7. The resolution confirming this change of organization was adopted on September 18, 2019 by LAFCo, is marked Exhibit B, and by reference incorporated herein.

I hereby certify that I have examined the above-cited resolution, including any terms and conditions, and the map description and have found these documents to be in compliance with Resolution 1243, adopted on September 18, 2019.

Dated: November 18, 2019

Martha Poyatos
Executive Officer

COMMISSIONERS: ANN DRAPER, CHAIR, PUBLIC • JOSHUA COSGROVE, VICE CHAIR, SPECIAL DISTRICT • RICH GARBARINO, City • DON HORSLEY, COUNTY • MIKE O'NEILL, CITY • WARREN SLOCUM, County • VACANT, SPECIAL DISTRICT

ALTERNATES: KATI MARTIN, SPECIAL DISTRICT • HARVEY RARBACK, CITY • JAMES O'NEILL, PUBLIC • DAVE PINE, COUNTY

STAFF: MARTHA POYATOS, EXECUTIVE OFFICER • REBECCA ARCHER, LEGAL COUNSEL • ROB BARTOLI, MANAGEMENT ANALYST

California Environmental Quality Act (CEQA) exempt under State CEQA Guidelines Section 15319(a) & (b) (Annexations of Existing Facilities and Lots for Exempt Facilities); and

NOW, THEREFORE, the Local Agency Formation Commission of the County of San Mateo DOES HEREBY RESOLVE, DETERMINE AND ORDER as follows:

Section 1. This proposal is approved, subject to the following conditions: none.

Section 2. The boundaries as set forth in the application are hereby approved as submitted and are as described in Exhibit "A" attached hereto and by this reference incorporated herein.

Section 3. The territory consists of 1.5 acres, is found to be uninhabited, and is assigned the following distinctive short form designation: Annexation of 20 Navajo Place, Portola Valley (APN 077-300-070) to the West Bay Sanitary District.

Section 4. Conducting authority proceedings are hereby waived in accordance with Government Code Section 56663 and this annexation is hereby ordered.

Section 5. Subsequent annexation to the On-Site Wastewater Disposal Zone is hereby approved.

APPROVED
SAN MATEO LOCAL AGENCY
FORMATION COMMISSION
455 COUNTY CENTER
REDWOOD CITY, CA 94063

EXHIBIT D PAGE 2 OF 3

Regularly passed and adopted this 18th day of September 2019.

Ayes and in favor of said resolution:

APPROVED
SAN MATEO LOCAL AGENCY
FORMATION COMMISSION
455 COUNTY CENTER
REDWOOD CITY, CA 94063

EXHIBIT B PAGE 3 OF 3

Commissioners: Ann Draper, Chair
Don Horsley
Ric Lohman
Kati Martin (Alternate)
Harvey Rarback (Alternate)
Warren Slocum

Noes and against said resolution:

None

Commissioners Absent ~~and/or Abstentions~~

Commissioners: Joshua Cosgrove, Rich Garbarino, Mike O'Neill

Ann Draper
Chair
Local Agency Formation Commission
County of San Mateo
State of California

ATTEST:

Man Poyat
Executive Officer
Local Agency Formation Commission

Date: 9/23/19

I certify that this is a true and correct copy of the resolution above set forth.

Date: 9/23/19

Rich Garbarino
Clerk to the Commission
Local Agency Formation Commission

THIS PAGE LEFT INTENTIONALLY BLANK



**WEST BAY SANITARY DISTRICT
AGENDA ITEM 5**

To: Board of Directors

From: Phil Scott, District Manager

Subject: Discussion and Direction on Recycled Water Projects – Sharon Heights and Bayfront, Including Project Status

A discussion will be held on the Recycled Water Projects – Sharon Heights and Bayfront Facility and other events related to the recycled water project including financing, design/build issues and grant applications. The Board will have opportunity to provide direction to staff and legal counsel.

The following is a disclosure statement required for any document, written report or brochure prepared in whole or in part pursuant to the Finance Agreement with the State Water Resources Control Board for the West Bay Sanitary District Recycled Water Project - Sharon Heights:

Funding for this project has been provided in full or in part through an agreement with the State Water Resources Control Board. California's Clean Water State Revolving Fund is capitalized through a variety of funding sources, including grants from the United States Environmental Protection Agency and state bond proceeds. The contents of this document do not necessarily reflect the views and policies of the foregoing, nor does mention of trade names or commercial products constitute endorsement or recommendation for use.

THIS PAGE LEFT INTENTIONALLY BLANK



**WEST BAY SANITARY DISTRICT
AGENDA ITEM 6**

To: Board of Directors

From: Phil Scott, District Manager

Subject: Report & Discussion on South Bayside Waste Management Authority (SBWMA)

The District's representative to South Bayside Waste Management Authority (SBWMA), President Fran Dehn, will report on any pertinent items regarding SBWMA business.

THIS PAGE LEFT INTENTIONALLY BLANK



**WEST BAY SANITARY DISTRICT
AGENDA ITEM 7**

To: Board of Directors

From: Phil Scott, District Manager

**Subject: Report & Discussion on Silicon Valley Clean Water (SVCW),
Including Discussion on SVCW CIP Program and Financing**

The District's representative to Silicon Valley Clean Water (SVCW), George Otte, will report on as any pertinent items regarding SVCW including Operations, CIP and Finance.

THIS PAGE LEFT INTENTIONALLY BLANK