

**Attachment S**

**Final Facility Plan Report**



Photo courtesy Javed Karim via Pexels

# West Bay Sanitary District **Recycled Water Facilities Plan**



**WEST BAY**  
SANITARY DISTRICT



Final - August 2015

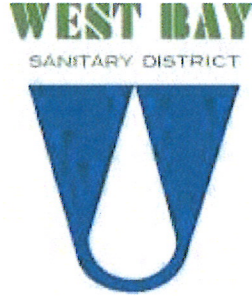

# Recycled Water Facilities Plan Final Report

Prepared by:

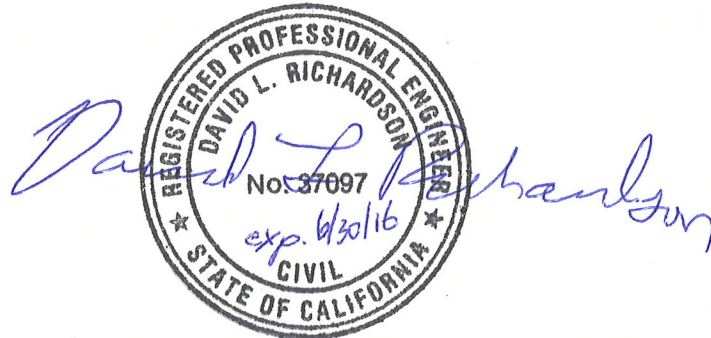

August 2015

**Table of Contents**

<b>Chapter 1</b>	<b>Introduction .....</b>	<b>1-1</b>
1.1	Background .....	1-1
1.2	Feasibility Study and Facilities Plan Objectives and Approach .....	1-3
1.3	Stakeholder Involvement .....	1-3
<b>Chapter 2</b>	<b>Study Area Characteristics .....</b>	<b>2-1</b>
2.1	Study Area.....	2-1
2.2	Water Demand .....	2-1
2.3	Water Supply.....	2-2
2.3.1	Water Supply.....	2-2
2.3.2	Groundwater Basin Characterization .....	2-2
<b>Chapter 3</b>	<b>Market Assessment.....</b>	<b>3-1</b>
3.1	Potential User Base and Demand Assessment .....	3-1
3.1.1	Potential Uses .....	3-1
3.1.2	Refinement of Potential Recycled Water Demands .....	3-2
3.1.3	Refinement of Potential Customers.....	3-3
3.1.4	Refinement of Potential Recycled Water Demands .....	3-6
<b>Chapter 4</b>	<b>Recycled Water Supply Characteristics.....</b>	<b>4-1</b>
4.1	Recycled Water Quality Requirements .....	4-1
4.1.1	Irrigation Water Quality Requirements .....	4-1
<b>Chapter 5</b>	<b>Wastewater Characteristics and Facilities.....</b>	<b>5-1</b>
5.1	Preliminary Wastewater Characteristics.....	5-1
5.2	Available Wastewater Flows .....	5-5
<b>Chapter 6</b>	<b>Treatment Requirements for Reuse .....</b>	<b>6-1</b>
6.1	Recycled Water Treatment Requirements .....	6-1
6.2	Treatment Alternatives .....	6-1
6.2.1	Membrane Bioreactor .....	6-1
6.2.2	Sequencing Batch Reactor with Filtration .....	6-3
6.2.3	Disinfection Alternatives .....	6-7
<b>Chapter 7</b>	<b>Project Alternatives.....</b>	<b>7-1</b>
7.1	Planning and Design Assumptions.....	7-1
7.1.1	Cost Estimate Basis .....	7-1
7.1.2	Unit Costs and Assumptions .....	7-2
7.2	Recycled Water Project Alternatives .....	7-3
7.2.1	Alternative A – Baseline Project .....	7-3
7.2.2	Alternative B – Baseline Project Plus SLAC.....	7-6
7.2.3	Alternative C – Baseline Project Plus Other Users .....	7-9
7.2.4	Alternatives Comparison .....	7-11
<b>Chapter 8</b>	<b>Recommended Project .....</b>	<b>8-1</b>
8.1	Facilities .....	8-1
8.2	Recommended Project Cost Estimate .....	8-5
8.3	Comparison to No Project Alternative (SFPUC Supply).....	8-6
<b>Chapter 9</b>	<b>Implementation Plan .....</b>	<b>9-1</b>
9.1	Institutional Needs.....	9-1
9.2	Financing Plan.....	9-1
9.2.1	Funding Opportunities .....	9-2
9.2.2	Funding Opportunity Summary .....	9-5
9.2.3	Construction Financing and Cash Flow.....	9-5
9.3	Preliminary Environmental Review.....	9-6
9.4	Design .....	9-6

9.5	Implementation Schedule .....	9-6
<b>Chapter 10</b>	<b>Conclusion.....</b>	<b>10-1</b>
<b>References</b>	<b>.....</b>	<b>.....</b>

**List of Tables**

<b>Table 2-1: Current and Projected Water Demands</b>	<b>2-2</b>
<b>Table 3-1: Standard Peaking Factors</b>	<b>3-3</b>
<b>Table 3-2: Potential Recycled Water Customers</b>	<b>3-4</b>
<b>Table 4-1: Landscape Irrigation Water Quality Comparison</b>	<b>4-1</b>
<b>Table 5-1: Water Quality Sampling Results</b>	<b>5-2</b>
<b>Table 5-2: Sand Hill Road Water Quality Sampling Summary</b>	<b>5-3</b>
<b>Table 5-3: Alpine Road Water Quality Sampling Summary</b>	<b>5-4</b>
<b>Table 5-4: Oak Ave Wastewater Flow Summary (June-July 2015)</b>	<b>5-6</b>
<b>Table 6-1: Water Quality Requirements for Title 22 Disinfected Tertiary Recycled Water</b>	<b>6-1</b>
<b>Table 6-2: Membrane Bioreactor Advantages and Disadvantages compared to a Sequencing Batch Reactor</b>	<b>6-3</b>
<b>Table 6-3: SBR Advantages and Disadvantages Compared to MBR</b>	<b>6-4</b>
<b>Table 6-4: Continuous Backwash Sand Filtration Evaluation</b>	<b>6-6</b>
<b>Table 6-5: Cloth Media Filtration Advantages and Disadvantages</b>	<b>6-7</b>
<b>Table 7-1: Facilities Development Criteria and Hydraulic Criteria</b>	<b>7-1</b>
<b>Table 7-2: O&amp;M Cost Assumptions</b>	<b>7-2</b>
<b>Table 7-3: Construction Unit Costs</b>	<b>7-2</b>
<b>Table 7-4: Alternative A Users</b>	<b>7-4</b>
<b>Table 7-5: Alternative A Main Facilities</b>	<b>7-4</b>
<b>Table 7-6: Alternative A Cost Estimate</b>	<b>7-6</b>
<b>Table 7-7: Alternative B Users</b>	<b>7-7</b>
<b>Table 7-8: Alternative B Main Facilities</b>	<b>7-8</b>
<b>Table 7-9: Alternative B Cost Estimate</b>	<b>7-9</b>
<b>Table 7-10: Alternative C Users</b>	<b>7-10</b>
<b>Table 7-11: Alternative C Main Facilities</b>	<b>7-10</b>
<b>Table 7-12: Alternative C Cost Estimate</b>	<b>7-11</b>
<b>Table 7-13: Alternatives Comparison</b>	<b>7-12</b>
<b>Table 8-1: Recommended Project Recycled Water Customers</b>	<b>8-1</b>
<b>Table 8-2: Design Criteria for Recommended Project</b>	<b>8-5</b>
<b>Table 8-3: Recommended Project Costs (April 2015 Dollars)</b>	<b>8-6</b>
<b>Table 8-4: Recommended Recycled Water Project vs. No Project Alternative (SFPUC Supply)</b>	<b>8-7</b>
<b>Table 9-1: Summary of Funding Opportunities</b>	<b>9-6</b>

**List of Figures**

<b>Figure 1-1: Project Location</b>	<b>1-2</b>
<b>Figure 2-1: Project Study Area</b>	<b>2-1</b>
<b>Figure 2-2: District Boundary and Groundwater Subbasins</b>	<b>2-3</b>
<b>Figure 2-3: San Francisquito Cone Area (USGS, 2002)</b>	<b>2-4</b>
<b>Figure 3-1: Accepted Treatment Levels for Water Reuse under California’s Title 22</b>	<b>3-2</b>
<b>Figure 3-2: Potential Recycled Water Customers and Demand Estimates</b>	<b>3-5</b>
<b>Figure 5-1: Water Quality Sampling Locations</b>	<b>5-1</b>
<b>Figure 5-2: Oak Avenue Flow Monitoring Location</b>	<b>5-5</b>

Figure 5-3: Wastewater Flow Diurnal Curve at Oak Avenue, Manhole 66 (June-July 2015)	5-6
Figure 5-4: District Collection System in Sharon Heights G&CC Area and Average Flow	5-7
Figure 6-1: MBR Process Flow Diagram	6-2
Figure 6-2: MBR Process Schematic	6-3
Figure 6-3: SBR Process Schematic	6-4
Figure 6-4: Continuous Backwash Sand Filter (Parkson Corporation DynaSand®)	6-5
Figure 6-5: Cloth Media Filter (Aqua Aerobic Systems AquaDisk®)	6-7
Figure 7-1: Alternatives Major Facilities	7-13
Figure 8-1: Recommended Project Facility-Planning Level Satellite Treatment Layout	8-2
Figure 8-2: Recommended Project Recycled Water Customers and Facilities	8-3
Figure 8-3: Influent Pump Station Configuration	8-4
Figure 9-1: Prop 84 Grant Process	9-3
Figure 9-2: Facilities Construction Grants and Loans Process	9-4
Figure 9-3: Cash Flow Chart	9-5
Figure 9-4: Design-Build Implementation Schedule	9-7

## **Appendices**

Appendix A -	Sand Hill Road Water Quality Data
Appendix B -	Alpine Road Water Quality Data
Appendix C -	Flow Monitoring Data
Appendix D -	Project Alternative Cost Estimates
Appendix E -	Environmental Checklist
Appendix F -	WBSD and Sharon Heights MOU

List of Abbreviations

AFY	acre feet per year
BAIRWMP	San Francisco Bay Area IRWM Plan
BOD	Biochemical Oxygen Demand
CCF	hundred cubic feet
CDPH	California Department of Public Health
CEQA	California Environmental Quality Act
CWSRF	Clean Water State Revolving Fund
DAC	disadvantaged community
DDW	Division of Drinking Water
DWR	Department of Water Resources
gpd	gallons per day
gpm	gallons per minute
hp	horsepower
IRWM	Integrated Regional Water Management
IS/MND	Initial Study/Mitigated Negative Declaration
ISRF	Infrastructure State Revolving Fund
LF	lineal feet
Market Survey	Recycled Water Market Survey
MBR	Membrane Bioreactor
MDD	maximum day demand
mg/L	milligrams per liter
mgd	million gallons per day
mJ/cm <sup>2</sup>	millijoule per square centimeter
mm	millimeter
MPMWD	Menlo Park Municipal Water District
MPN	most probable number
NEPA	National Environmental Policy Act
NTU	Nephelometric Turbidity Units
PEIR	Program Environmental Impact Report
PHD	peak hour demand
Plan	Recycled Water Facility Plan
Project	Recycled Water Project
psi	pounds per square inch
RWQCB	Regional Water Quality Control Board
SBR	Sequencing Batch Reactor
scfm	standard cubic feet per minute
SF	square feet
SFPUC	San Francisco Public Utilities Commission
Sharon Heights G&CC	Sharon Heights Golf & Country Club
SLAC	Stanford Linear Accelerator Center
SRF	State Revolving Fund

SVCW	Silicon Valley Clean Water
SWRCB	State Water Resource Control Board
TDS	total dissolved solids
Title 22	Title 22 California Code of Regulations
TKN	Total Kjeldahl Nitrogen
TN	Total Nitrogen
TSS	total suspended solids
USBR	US Bureau of Reclamation
UV	Ultraviolet
UWMP	Urban Water Management Plan
WBSD	West Bay Sanitary District
WRFP	Water Recycling Funding Program
WSIP	Water System Improvement Program



## Chapter 1 Introduction

West Bay Sanitary District (WBSD) is embarking on a critical water supply evaluation which will help the District define its role in utilizing its wastewater resource now and into the future. This Recycled Water Facility Plan (Plan) documents the District's efforts to begin to define this important role.

This chapter of the report includes background on the District and the Recycled Water Facility Plan, documentation of the goals and drivers for considering implementation of a Recycled Water Project (Project) in the service area, discussion of the Plan objectives and approach, description of stakeholder involvement during the course of the Plan, and summary of the report organization.

### 1.1 Background

West Bay Sanitary District (WBSD) maintains and operates over 200 miles of main line sewer in the City of Menlo Park and portions of the Cities of East Palo Alto, Redwood City, the Towns of Atherton, Woodside and Portola Valley and portions of Unincorporated San Mateo and Santa Clara Counties. The raw wastewater collected by WBSD is conveyed to Silicon Valley Clean Water (SVCW) where the wastewater is treated and discharged or reused. Figure 1-1 illustrates the WBSD boundaries and project location.

In 2014, WBSD completed a Recycled Water Market Survey (Market Survey) (RMC 2014), including preliminary market and recycled water supply assessment and evaluation of three conceptual alternatives to serve recycled water customers to assess overall feasibility of expanding the service area water supply portfolio to include recycled water.

The WBSD decided to further evaluate a satellite treatment plant at Sharon Heights Golf & Country Club (Sharon Heights G&CC) and recycled water use at the golf course and other potential users in the vicinity of the golf course.

Figure 1-1: Project Location

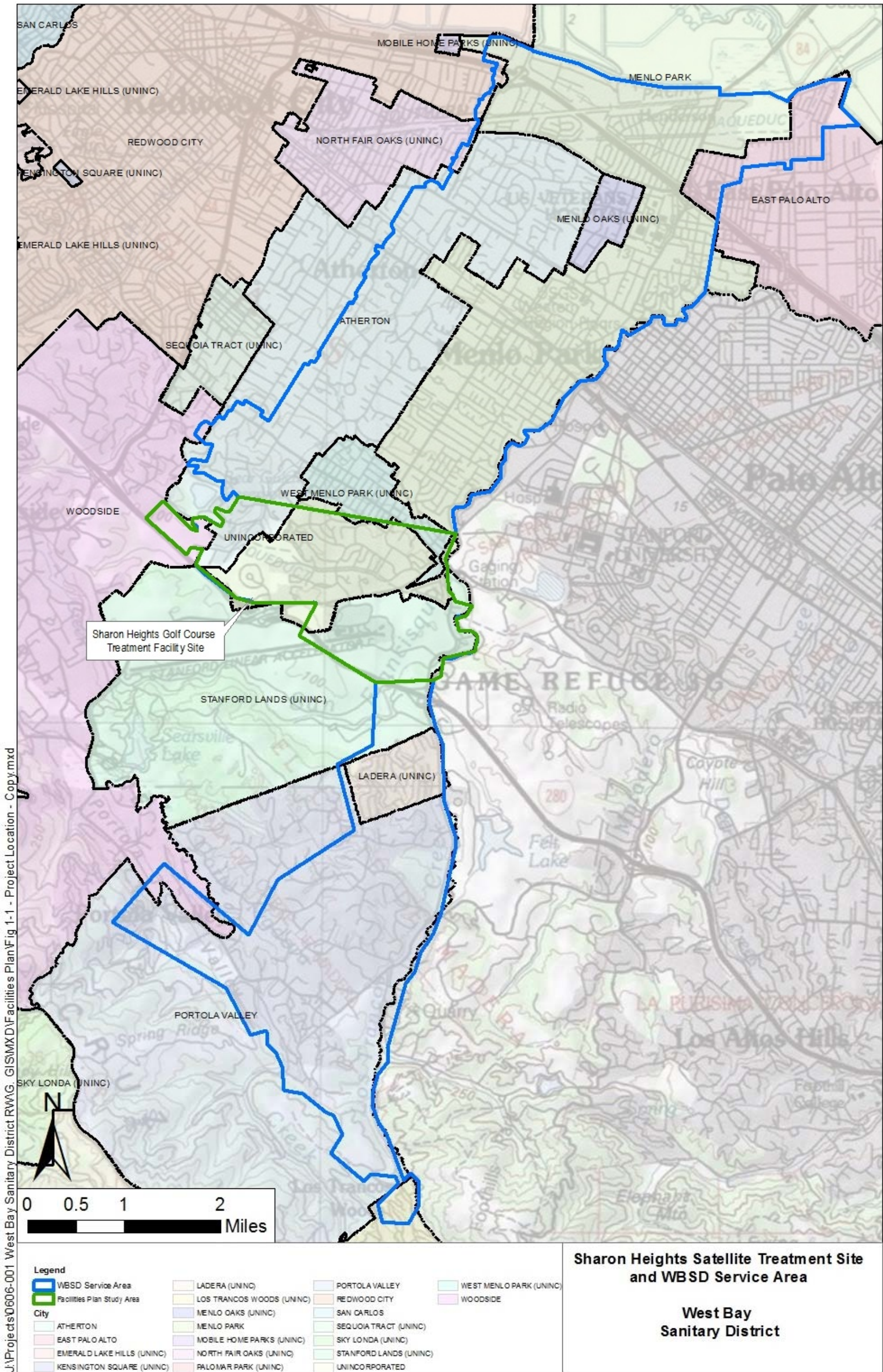

J:\Projects\0606-001 West Bay Sanitary District RWG\_GIS\MXD\Facilities Plan\Fig 1-1 - Project Location - Copy.mxd

## 1.2 Feasibility Study and Facilities Plan Objectives and Approach

The objectives of this Study and Plan are:

1. Refine the recycled water market assessment in the vicinity of Sharon Heights GC&CC;
2. Evaluate wastewater diversion pump station locations, treatment alternatives, and distribution alternatives;
3. Identify a recommended project, including target customers, planning-level design criteria, and planning-level cost estimate;
4. Prepare an implementation plan for the recommended project, including implementation schedule, construction financing plan and preliminary environmental checklist

## 1.3 Stakeholder Involvement

During the preparation of this Plan, stakeholder involvement and outreach focused on individual meetings with Sharon Heights G&CC and Stanford Linear Accelerator (SLAC) National Accelerator Laboratory. Should WBSD decide to move forward with a recycled water project, it would initiate more extensive public involvement – at a minimum, through the environmental review and public project approval process.

## Chapter 2 Study Area Characteristics

This chapter provides additional background information on the characteristics of the WBSD Study Area including a discussion of water demand and supply, and a characterization of the underlying groundwater basin.

### 2.1 Study Area

The Study Area for this Plan is defined as the estimated 2.5-square-miles shown on Figure 2-1 including Sharon Heights G&CC and potential users in the WBSD service area. The majority of Study Area is situated in the City of Menlo Park. Wastewater in the Study Area flows in from the upper watershed from Portola Valley. Potable water in this portion of Menlo Park is supplied by the Menlo Park Municipal Water District (MPMWD) (water retailer) and the San Francisco Public Utilities Commission (SFPUC) (water wholesaler).

Figure 2-1: Project Study Area

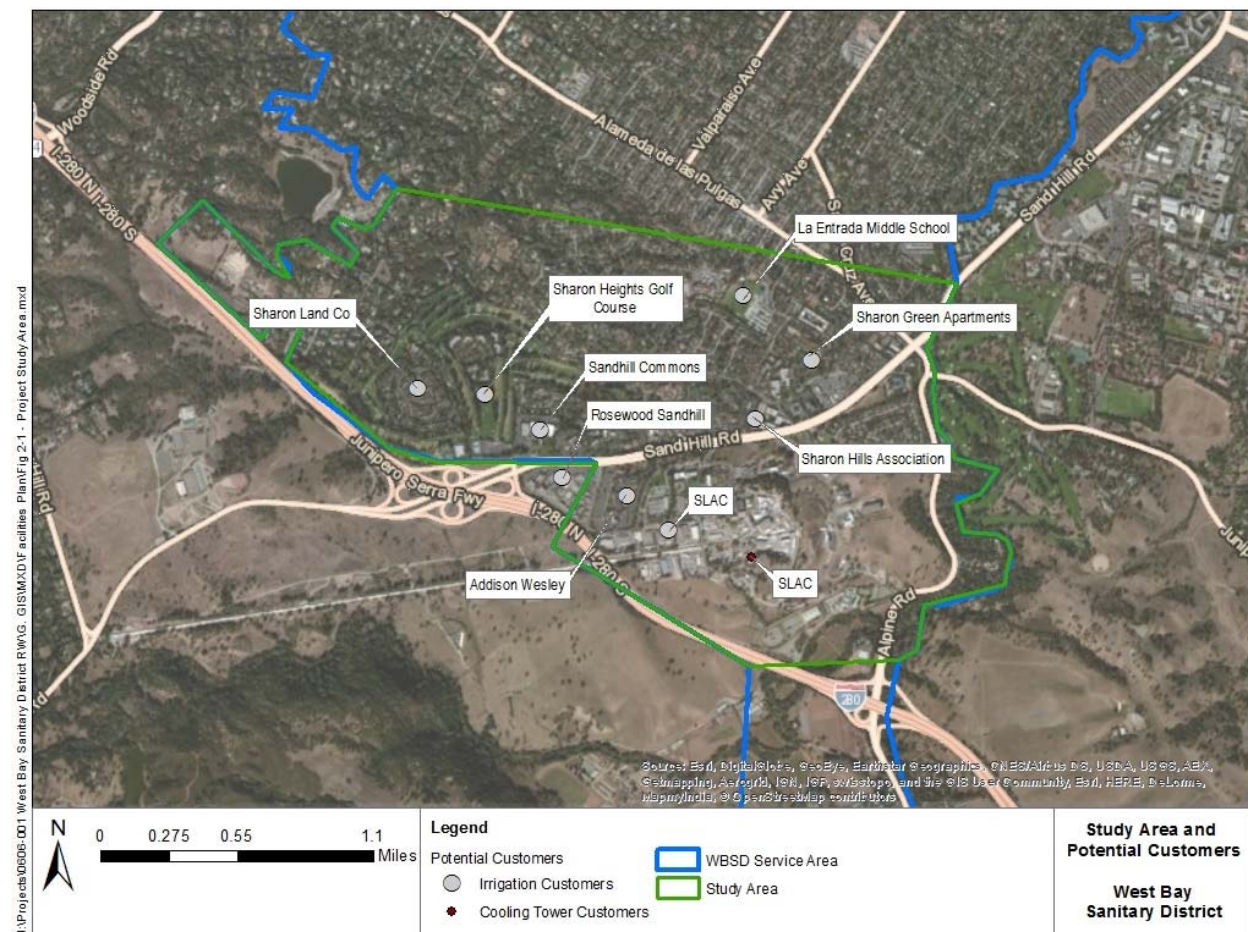

### 2.2 Water Demand

The population of the City of Menlo Park served by the MPMWD is expected to increase by approximately 8.6% between 2015 and 2035. In addition to residential growth, the City is anticipating commercial development in the near-term. Table 2-1 is a summary of the current and projected water demands in the MPMWD service area between 2005 and 2035 from the *Final 2010 Urban Water Management Plan and Update to the Water Shortage Contingency Plan (Amended June 2014)* prepared

by Winzler & Kelly for the City of Menlo Park. Projected water demands take into account per capita demand reductions required by Senate Bill x7-7 and planned growth. Values are shown as acre-foot per year (AFY).

**Table 2-1: Current and Projected Water Demands**

	2005	2010	2015	2020	2025	2030	2035
Demand (AFY)	4,004	3,391	3,745	3,400	3,471	3,549	3,630

Source: UWMP, 2010 (Amended 2014)

## 2.3 Water Supply

With increasing water demands forecasted over the next 20 years and the Study Area's exclusive dependence on the SFPUC water, adequate water supply for the region is an issue that recycled water could help address.

### 2.3.1 Water Supply

Since the 1960's, the City's sole source of potable water has been the City and County of San Francisco's regional system, operated by the SFPUC. The SFPUC system supply is predominantly snowmelt from the Sierra Nevada Mountains, delivered through the Hetch Hetchy aqueducts. The SFPUC wholesales water to MPMWD which is the water retailer for customers within the City.

The MPMWD's dependence on SFPUC for potable water supplies leads to several potential issues that may be addressed or reduced by the use of recycled water in the City:

- **Water Supply Availability during Average Year.** Per the MPMWD's contract with SFPUC, the MPMWD has an Individual Supply Guarantee of approximately 4,993 AFY through 2034.
- **Water Supply Reliability during Periods of Drought.** The majority of SFPUC water supplies are surface water and susceptible to drought conditions. Supplying recycled water to non-potable demands would dampen drought impacts on potable water supply.
- **Water Supply Reliability during Service Disruptions.** The majority of SFPUC water supplies are piped in from outside the City's immediate area. The City's exclusive dependence on the SFPUC for potable water leaves the City in a vulnerable position to service disruptions and outages if an event (e.g. earthquake) damages the transmission system. To address this issue, SFPUC is in the midst of undertaking the WSIP to address reliability, and seismic protection in their system. In addition, recycled water would allow for the use of a local, reliable water supply for non-potable demands in the event of service disruptions.
- **Water Supply Cost.** In addition to the consumption charge, there is a capital surcharge and a fixed monthly service charge based on meter size. Current water costs for Sharon Heights G&CC range based on usage, however on recent bills (July 2015 and March 2015) which included water basic charges, water consumption, services fees and user taxes equated to approximately \$2,611 - 2,713/AF. Consumption charges are based on four tiers ranging from \$2.68/CCF to \$5.39/CCF. The majority (> 93%) of Sharon Heights G&CC is from the most expensive tier, Tier 4.

### 2.3.2 Groundwater Basin Characterization

The majority of the District's service area overlies the San Mateo Plain groundwater subbasin, as shown on Figure 2-2. The San Mateo subbasin borders the Santa Clara Valley subbasin along its eastern boundary where it follows the county-line along San Francisquito Creek.

Figure 2-2: District Boundary and Groundwater Subbasins

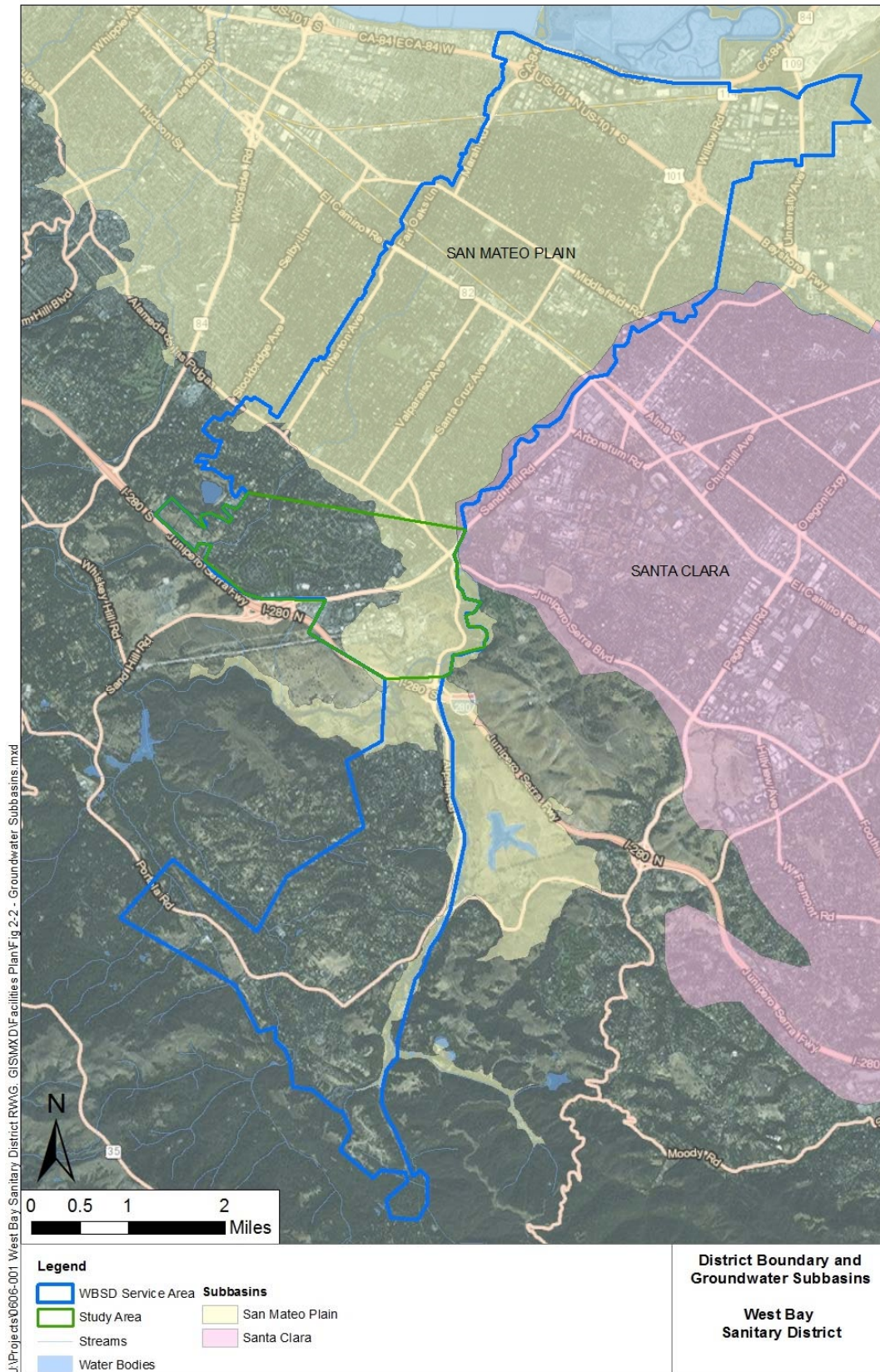

This area is also known as the San Francisquito Cone, San Francisquito Creek subbasin, or San Francisquito Creek alluvial fan, shown in Figure 2-3.

**Figure 2-3: San Francisquito Cone Area (USGS, 2002)**

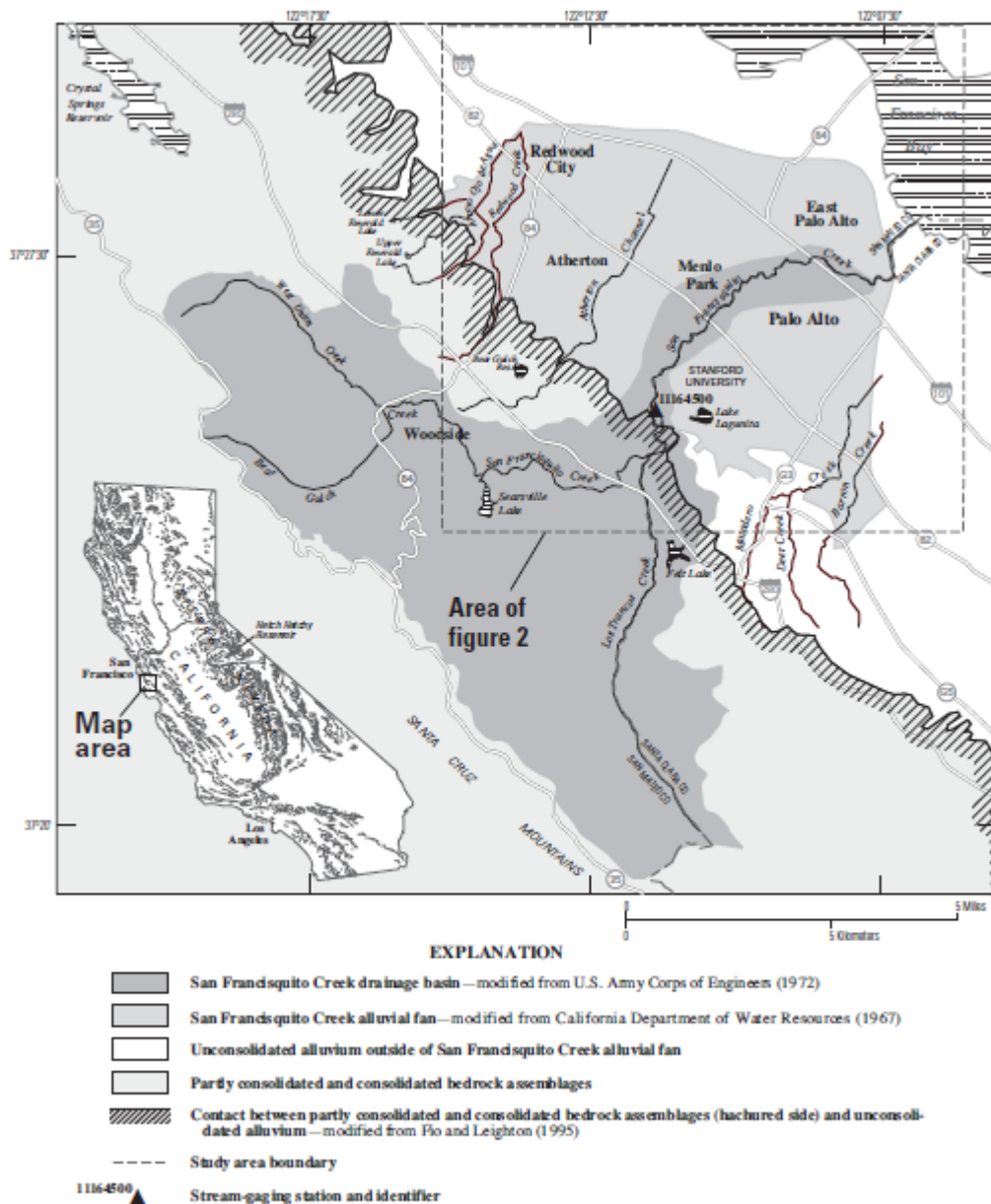

Currently, there is no Groundwater Management Plan or groundwater managing authority within the San Mateo Plain basin, which is dissimilar to the highly managed, neighboring Santa Clara Valley Groundwater subbasin. The City of East Palo Alto is beginning a Groundwater Management Plan process for areas within the jurisdiction of the City; and there is an active stakeholder group for groundwater management of the San Francisquito Creek subbasin operating under a draft Memorandum of Understanding.

Beneficial uses of the groundwater subbasin include irrigation, public and private drinking water. Of the wells installed within the basin, approximately 90% are solely used for irrigation purposes (RWQCB,

2003). In the area underlying the District's service area, two aquifer systems are present; a shallow aquifer located up to 120 feet below ground surface (ft bgs) and a deeper aquifer located between 200-400 ft bgs (RWQCB, 2003). The densest clustering of wells is within Atherton and Menlo Park, and these wells are typically installed within the deeper aquifer, where the more northern wells are generally installed within the shallow aquifer (RWQCB, 2003). During the 1987-92 drought, over 100 residential wells were installed in the town of Atherton, raising concerns related to overpumping such as land subsidence and salt-water intrusion (USGS, 1997).



## Chapter 3 Market Assessment

A preliminary recycled water market assessment was conducted as part of the *Recycled Water Market Survey*. The assessment consisted of three major tasks: preliminary demand assessment, preliminary water supply assessment, and preliminary water quality assessment.

For the purpose of this Plan, the preliminary recycled water market assessment will be refined as follows:

- **Refine customer demand estimates and identify demand characteristic, and identify other potential customers near Sharon Heights G&CC** – the Market Survey only considered the largest existing potable water customers. Other potential customers (existing and future) in the Study Area will be considered.
- **Confirm/refine the water quality needs** – the Market Survey identified cursory water quality needs based on typical water quality objectives for certain category of customers; this assessment will be refined based on additional monitoring and will consider both planned treated water quality and an identification of customer needs related to water quality.

This refined market assessment will form the basis for evaluating recycled water distribution alternatives.

### 3.1 Potential User Base and Demand Assessment

Based on discussions with Sharon Heights management, WBSD has decided to further develop the “Near-Term Conceptual Project – Sharon Heights Satellite Treatment” identified in the *Market Survey*. Refinements to potential uses, customers and recycled water demands discussed in the following sections apply specifically to the development of a satellite treatment plant at Sharon Heights.

#### 3.1.1 Potential Uses

A list of potential uses was developed in the Market Survey based on recyclable water uses allowable under Title 22 of the California Code of Regulations with disinfected tertiary recycled water as the target level of treatment. A preliminary database of potential recycled water customers based on the identified uses was developed in the Market Survey. No other uses other than those identified in the Market Survey were considered herein.

Figure 3-1 includes a list of potential recycled water uses allowed by the Department of Drinking Water (DDW) (formerly the Department of Public Health) for various levels of treatment, with disinfected tertiary recycled water highlighted as the target level of treatment for this project. Potential uses in WBSD’s service area are categorized as irrigation and commercial cooling tower uses.

**Figure 3-1: Accepted Treatment Levels for Water Reuse under California’s Title 22**

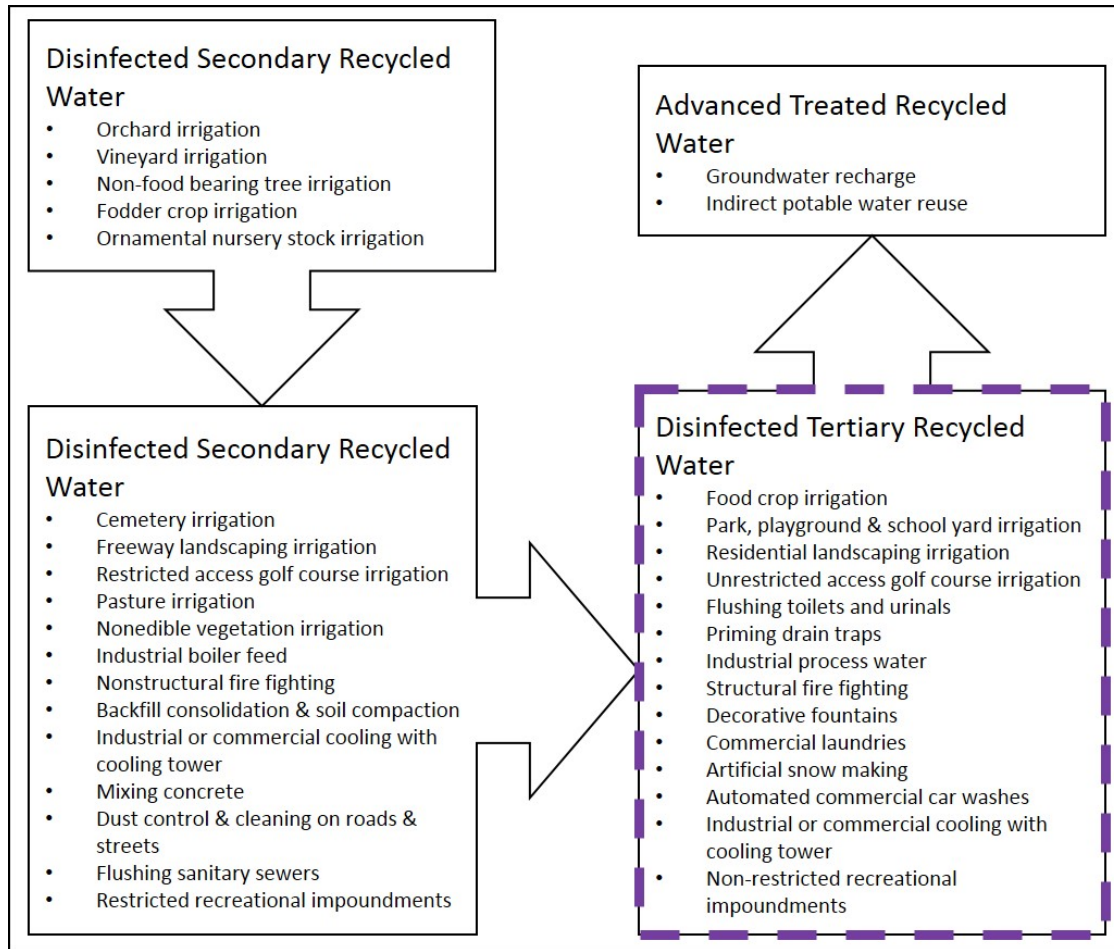

Notes:

1. “Disinfected Tertiary Recycled Water” is the category most commonly referred to as recycled water in California under Title 22.

This figure does not represent an all-inclusive list of recycled water uses. See Statutes for Regulations Related to Recycled Water, (SWRCB, 2015) for requirements for impoundment, cooling and other uses:

([http://www.waterboards.ca.gov/drinking\\_water/certlic/drinkingwater/documents/lawbook/RWregulations\\_20150625.pdf](http://www.waterboards.ca.gov/drinking_water/certlic/drinkingwater/documents/lawbook/RWregulations_20150625.pdf)).

### 3.1.2 Refinement of Potential Recycled Water Demands

Facilities for conveying treated recycled water are sized based on peak demand periods. Two peak flow situations were defined as criteria for development of the recycled water distribution system in the market assessment: maximum day demand (MDD) and peak hour demand (PHD). MDD is defined as the average daily demand of a customer during the peak month of the year. PHD is defined as the maximum anticipated flow rate delivered to a customer (in gallons per minute) during MDD conditions. MDD and PHD factors were updated from the market assessment based on use type and are discussed below. Revised MDD and PHD values are summarized in Table 3-1.

#### Irrigation Demand Peaking Demand Factors

Based on data from the Western Regional Climate Center, July is the peak demand month for the WBSD service area for irrigation users. The following describes refinements to irrigation MDD and PHD factors:

- Maximum day demand – The irrigation MDD was refined using data from the MPMWD monthly irrigation water records for Sharon Heights G&CC in 2013. A monthly peaking factor was estimated at 2.5. MDD was estimated at 20 percent more than the monthly peaking factor for a value of 3.0.
- Peak hour demand – Irrigation-only customers typically operate at night for an 8-hour irrigation period. Therefore, the PHD factor was estimated at 3.0 (24-hour/8-hour irrigation = 3.0). This value did not change from the market assessment.

**Cooling Demand Peaking Demand Factors**

Cooling Tower MDD and PHD were provided by SLAC and are shown in Table 3-1.

**Table 3-1: Standard Peaking Factors**

Peaking Factors	Type of Use			
	Prelim. Irrigation Factors	Revised Irrigation Factors	Prelim. Cooling Tower Factors	Revised Cooling Tower Factors <sup>1</sup>
Max Day Demand to Avg. Annual Demand Factor	2.0	3.0 <sup>1</sup>	1.0	2.3
Peak Hour Demand to Max Day Demand Factor	3.0	3.0 <sup>1</sup>	1.0	1.7
Peak Hour Demand to Avg. Annual Demand Factor	6.0	9.0 <sup>1</sup>	1.0	4.0

Footnotes:

1. Estimated from 2013 monthly irrigation meter data for Sharon Heights G&CC
2. Peaking factors provided by SLAC

**3.1.3 Refinement of Potential Customers**

In the Market Survey, Sharon Heights was the sole targeted user for the Near-Term Conceptual Project. As part of this Plan, the list of potential recycled water customers was extended to include customers in the preliminary database in the vicinity of Sharon Heights. Potential users are summarized in Table 3-2 and shown in Figure 3-2.

Table 3-2: Potential Recycled Water Customers

Customer Name	Customer Type	Recycled Water Use Type	Prelim. Average Demand (AFY)	Revised Planning Demand (AFY)
Sharon Heights Golf Course	Farm – Irrigation	Irrigation	152	152
SLAC National Accelerator Laboratory	Commercial – Industrial	Cooling Tower	N/A	59 <sup>1</sup>
SLAC National Accelerator Laboratory	Commercial – Industrial	Irrigation	N/A	25 <sup>1</sup>
La Entrada Middle School	Commercial – Business	Irrigation	28	28
Rosewood Sand Hill	Commercial – Business	Irrigation	46	24
Sand Hill Commons	Commercial – Business	Irrigation	22	11
Addison Wesley	Commercial – Business	Irrigation	10	10
Sharon Land Co	Commercial – Business	Irrigation	10	10
Sharon Green Apartments	Residential – Multi	Irrigation	4	6
Sharon Hills Association	Residential – Multi	Irrigation	2	2

Footnotes:

1. Based on assumed seven months of recycled water delivery

Figure 3-2: Potential Recycled Water Customers and Demand Estimates

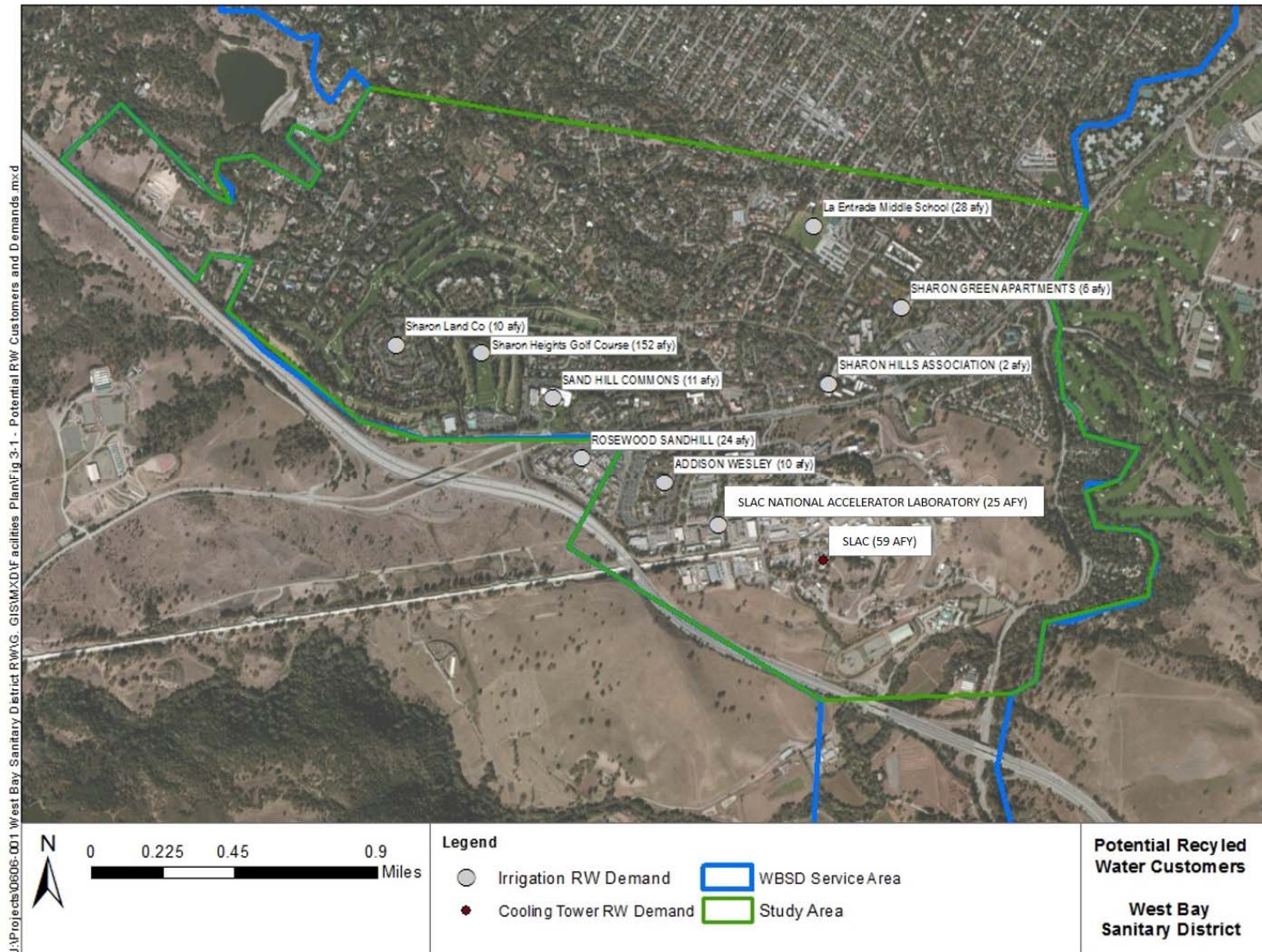

### **3.1.4 Refinement of Potential Recycled Water Demands**

The recycled water demand methodologies described in the market assessment were refined by a reexamination of the City of Menlo Park meter data from 2011 to 2013 for the extended list of potential users and are described below. All recycled water demand except for a portion of SLAC's demand for its cooling towers was assumed as irrigation demand.

To determine average annual demand for each user, monthly records for each applicable meter were summed together for yearly totals and converted from hundred cubic feet (CCF) units to acre-feet per year (AFY). Yearly totals were averaged to determine average annual demand. Revised annual demands are summarized in Table 3-2.

#### **Sharon Heights and Rosewood Sand Hill**

Irrigation meter data were separated from commercial meter data. Demand for Sharon Heights and Rosewood Sand Hill was estimated based on the assumption that 100 percent of their water use recorded on the separate irrigation meters could be converted to recycled water.

#### **SLAC**

Cooling tower demands were provided by SLAC. Irrigation demand was estimated based on the assumption that 50 percent of the difference between total potable demand (estimated from meter data) and cooling tower demand could be converted to recycled water.

#### **Other Users**

Irrigation demand for the remaining commercial and multi-family residential users were based on the assumptions that 50 percent and 10 percent, respectively, of water use could be converted to recycled water.

## Chapter 4 Recycled Water Supply Characteristics

This section describes the potential recycled water supplies available for production of recycled water generated in the WBSD service area.

### 4.1 Recycled Water Quality Requirements

Potential irrigation customers have different water quality needs according to their intended use. The following section describes water quality guidelines for landscape irrigation, the primary type of demand within WBSD. The section also describes the recommended level of treatment based on these requirements.

#### 4.1.1 Irrigation Water Quality Requirements

Water quality guidelines for landscape use are well established. Table 4-1 characterizes three degrees of restriction (none, slight to moderate and severe) for use of recycled water in landscaped irrigation based on various water quality constituents (although specific requirements vary depending on the type of plant) and provides a comparison to the proposed satellite treatment plant tertiary effluent water quality.

**Table 4-1: Landscape Irrigation Water Quality Comparison**

Constituent	Units	Degree of Restriction on Use <sup>1</sup>		
		None	Slight to Moderate	Severe
<b>Salinity</b>				
TDS	mg/L	< 450	450 - 2,000	> 2,000
<b>Specific Ion Toxicity</b>				
Sodium (Na) <sup>2,3</sup>	mg/L	< 70	> 70	
Chloride (Cl) <sup>2,3</sup>	mg/L	< 100	> 100	
Boron (B)	mg/L	< 0.7	0.7 - 3.0	> 3.0
<b>Miscellaneous Effects</b>				
pH	-		6.5 - 8.4	
Total Nitrogen <sup>4</sup>	mg/L	< 5	5 - 30	> 30
Bicarbonate <sup>5</sup>	mg/L	< 90	90 - 500	> 500

Footnotes:

1. Adapted from Metcalf and Eddy, 2007
2. Values apply to most tree crops and woody ornamentals which are sensitive to sodium and chloride
3. With overhead sprinkler irrigation and low humidity (< 30%), sodium or chloride levels greater than 70 or 100 mg/L, respectively, have resulted in excessive leaf adsorption and crop damage to sensitive crops
4. Total nitrogen should include nitrate-nitrogen, ammonia-nitrogen, and organic-nitrogen. Although forms of nitrogen in wastewater vary, the irrigated plant responds to the total nitrogen
5. Overhead sprinkling only

With the exception of nitrogen, the constituents in Table 4-1 are not removed by conventional wastewater or tertiary treatment processes. Therefore, recycled water constituent levels are likely to similar to the source wastewater constituent levels. Based on preliminary water quality monitoring data presented in Section 5.1, sodium and chloride levels in the influent wastewater to the Sharon Heights satellite plant fall within the “None or No Problem” guideline category.

Sodium and chloride are of primary concern when woody ornamentals or trees are the irrigated plant species, causing ion toxicity resulting in problems with root absorption of water. This may result in stunted growth, wilting, leaf burn, leaf drop and maybe plant death. However, there are multiple management strategies that parks and other facilities can implement (see discussion below).

For the Sharon Heights satellite treatment concept, no adverse effects to turf would be anticipated based on the chloride and sodium levels in the WBSD recycled water, although turf used for golf greens can be more sensitive to water quality because the grass is stressed due to being cut very short.



## Chapter 5 Wastewater Characteristics and Facilities

Sharon Heights G&CC has an available site for a satellite treatment facility and is the target facility location. Sharon Heights G&CC managers have previously investigated alternative sources of water for irrigation at the course and have a high desire to use recycled water as an alternative to the Hetch-Hetchy water supply.

### 5.1 Preliminary Wastewater Characteristics

Water quality has been investigated at several locations throughout the WBSD service area including Portola Valley at the 36-inch sewer in Alpine Road, 10-inch sewer in Sand Hill Road at Leland Avenue, and at the Main Meter Effluent location. Figure 5-1 shows the 36-inch Alpine Road and 10-inch Sand Hill Road sampling locations. The Main Meter Effluent sampling location is located at the downstream end of the WBSD collection system near Marsh Road and is not shown on Figure 5-1.

Figure 5-1: Water Quality Sampling Locations

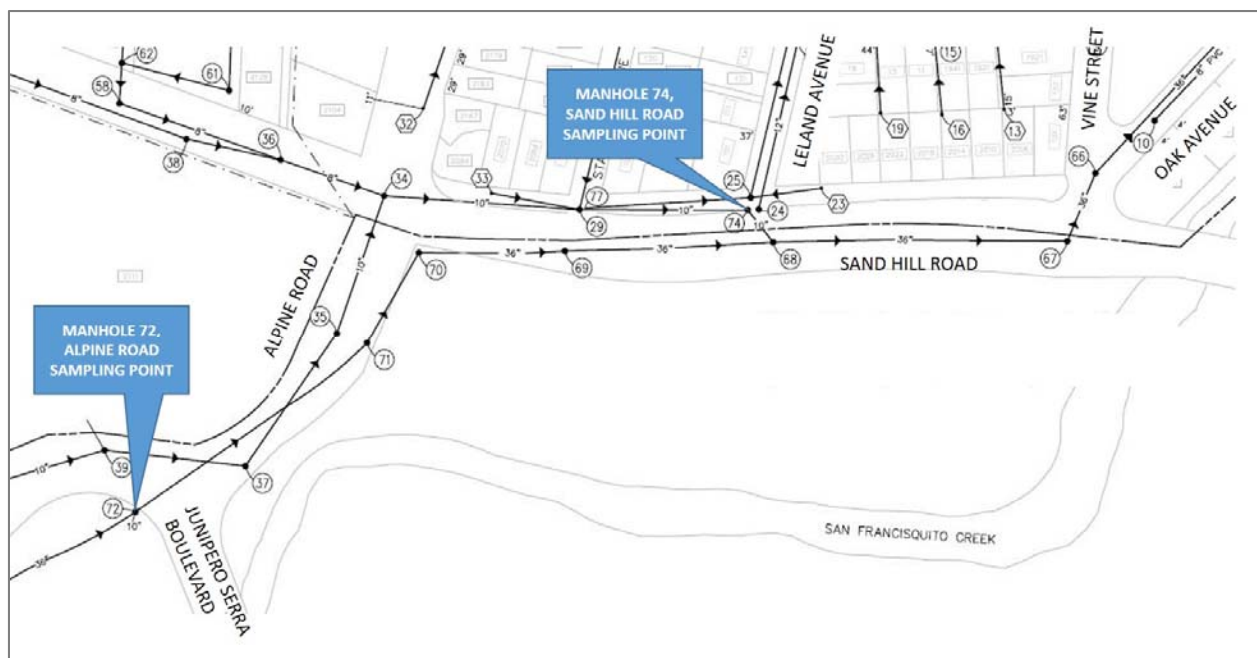

Table 5-1 summarizes the average of the analysis results from three sampling events in May 2014 at Alpine Road and at the Main Meter Effluent sampling location. Table 5-2 and Table 5-3 summarize the water quality results from sampling events in December 2014 and in April and May 2015 at Sand Hill Road and Alpine Road, respectively.

**Table 5-1: Water Quality Sampling Results**

Constituent	Unit	Alpine Road at Junipero Serra Boulevard	Main Meter Effluent Location
Silica	mg/L	8.2	11
Sodium	mg/L	51	333
Chloride	mg/L	43	647
Alkalinity	mg/L as CaCO <sub>3</sub>	320	327
Bicarbonate Alkalinity	mg/L as CaCO <sub>3</sub>	320	327
Total Dissolved Solids (TDS)	mg/L	320	1,500
Total Nitrogen (TN)	mg/L	66	50

Table 5-1 shows a significant difference between Portola Valley wastewater and the District's Main Meter wastewater salinity (TDS, chloride, and sodium) levels. It is believed that majority of the salinity increase is due to infiltration from saline groundwater into the collection system in the lower elevation portions of the system near San Francisco Bay.

Table 5-2 shows the minimum, maximum and average values for constituents from sampling events in December 2014 and April and May 2015 at Sand Hill Road. Water quality sampling data at Sand Hill Road are included in Appendix A. An elevated salinity level occurred on December 12, 2014 and is attributed to a cooling tower blowdown event by SLAC. SLAC is required to notify WBSD of all blowdown events.

**Table 5-2: Sand Hill Road Water Quality Sampling Summary**

Constituent	Unit	Minimum	Maximum	Average
Boron	mg/L	0.12	0.32	0.21
Calcium	mg/L	15	54	23
Magnesium	mg/L	5.3	27	12
Sodium	mg/L	41	220	72
Ammonia as NH <sub>3</sub>	mg/L	22	150	60
Biochemical Oxygen Demand (BOD)	mg/L	220	460	332
Total Dissolved Solids (TDS)	mg/L	320	870	423
Total Suspended Solids (TSS)	mg/L	160	560	362
Silica	mg/L	13	22	18
Total Kjeldahl Nitrogen (TKN)	mg/L	38	83	65
Total Nitrogen (TN)	mg/L	39	83	65
Phosphorus	mg/L	4.1	9.7	7.1
Chloride	mg/L	0.82	310	72
Nitrate	mg/L	ND	1.1	NA
Nitrite	mg/L	ND	ND	NA

## Notes:

1. Composite samples were collected on 12/10/14-12/11/14, 4/16/15, 4/21/15-4/22/15, 5/6/15-5/11/15, 5/14/15-5/19/15 at Manhole 74 in Sand Hill Road
2. NA: not applicable
3. ND: Non-detect

Table 5-3 shows the minimum, maximum and average values for constituents from sampling events in December 2014 and April and May 2015 at Alpine Road. Water quality sampling data at Alpine Road are included in Appendix B.

Table 5-3: Alpine Road Water Quality Sampling Summary

Constituent	Unit	Minimum	Maximum	Average
Boron	mg/L	0.14	0.32	0.24
Calcium	mg/L	11	51	29
Magnesium	mg/L	5.6	23	9
Sodium	mg/L	48	280	79
Ammonia as NH <sub>3</sub>	mg/L	22	290	74
Biochemical Oxygen Demand (BOD)	mg/L	230	1,500	492
Total Dissolved Solids (TDS)	mg/L	310	1,000	443
Total Suspended Solids (TSS)	mg/L	230	3,300	804
Silica	mg/L	13	22	18
Total Kjeldahl Nitrogen (TKN)	mg/L	46	110	76
Total Nitrogen (TN)	mg/L	46	110	76
Phosphorus	mg/L	5.0	15	9
Chloride	mg/L	47	380	92
Nitrate	mg/L	ND	0.83	NA
Nitrite	mg/L	ND	ND	NA

## Notes:

1. Composite samples were collected on 12/10/14-12/11/14, 4/16/15, 4/21/15-4/22/15, 5/6/15-5/11/15, 5/14/15-5/19/15 at Manhole 72 in Alpine Road
2. NA: not applicable
3. ND: Non-detect

The 10-inch sewer in Sand Hill Road and 36-inch sewer in Alpine Road intersect at Manhole 58 where the combined flow continues north in a 36-inch sewer in Oak Avenue. The proposed influent pump station (discussed in Section 8.1) would divert flow from the 36-inch sewer in Oak Avenue.

The preliminary Sand Hill Road and Alpine Road sampling results for the 10-inch and 36-inch sewers, respectively, show that TDS and chloride fall within the “No Use Restriction” guideline categories listed in Table 4-1. Average sodium values for the two locations are slightly higher than the “No Use Restriction” value of less-than 70 mg/L. For the Sharon Heights satellite plant, no adverse effects to turf would be anticipated based on the TDS, chloride and sodium levels found during preliminary sampling of the proposed influent wastewater flows.

## 5.2 Available Wastewater Flows

The satellite treatment project requires diversion of wastewater flow from the existing collection system to the new treatment facilities. As the Sharon Heights G&CC treatment facility is located at the upper end of the WBSD collection system, there is minimal flow available adjacent to the facility. Therefore, wastewater needs to be diverted from a trunk line further downstream where adequate flows are available to support the project. Figure 5-4 shows the Sharon Heights treatment location and the existing collection system. Figure 5-4 also shows average wastewater flows determined from the sewer system model prepared in May 2014 for the Market Survey. Based on the model results, the 36-inch trunk line located in Oak Avenue was identified as the target line from which to divert flow.

Flow monitoring was conducted by WBSD in June and July 2015 at Manhole 66 in the 36-inch sewer in Oak Avenue. Figure 5-2 shows the Oak Avenue flow monitoring location.

**Figure 5-2: Oak Avenue Flow Monitoring Location**

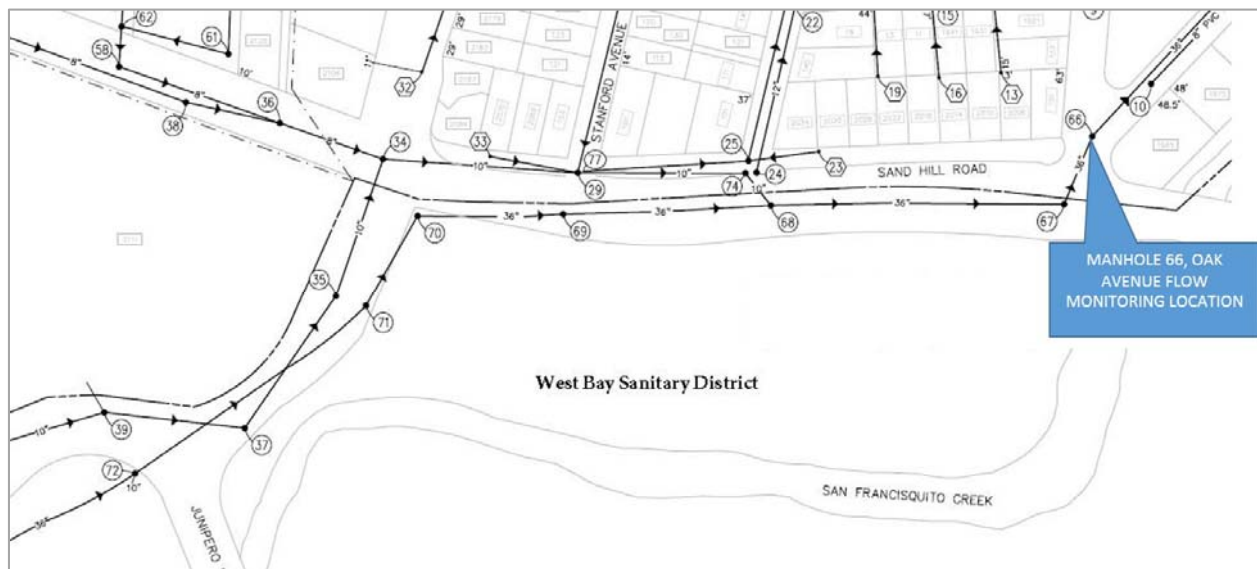

Preliminary flow monitoring at Oak Avenue occurred between 6/12/15 and 7/9/15. Figure 5-3 shows the average hourly diurnal curve over the monitoring period. The diurnal curve was created from hourly data between 6/12/15 and 6/28/15 and 15-minute data between 6/29/15 and 7/9/15. Data are included in Appendix C.

**Figure 5-3: Wastewater Flow Diurnal Curve at Oak Avenue, Manhole 66 (June-July 2015)**

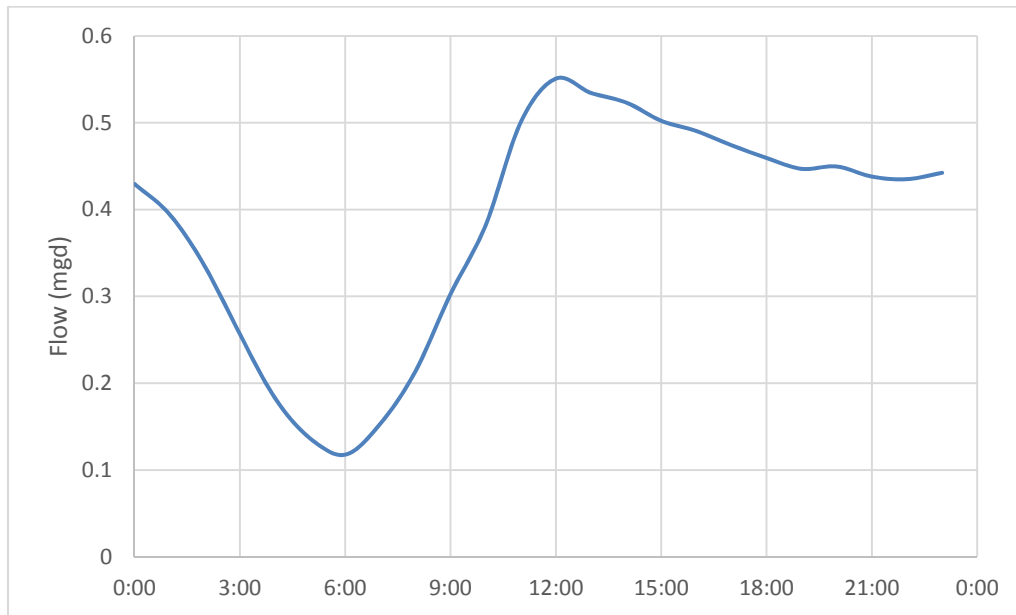

Notes:

1. Curve was created from hourly data between 6/12/15 and 6/28/15 and 15-minute data between 6/29/15 and 7/9/15

Table 5-4 summarizes preliminary data for the average daily flow, average minimum hourly flow and average maximum hourly flow from the June-July 2015 flow monitoring at Oak Avenue. Average daily flow was calculated at less than 0.4 mgd which is approximately 0.1 mgd less than determined in the May 2014 sewer model.

**Table 5-4: Oak Ave Wastewater Flow Summary (June-July 2015)**

Flow	June-July 2015 Preliminary Flow Monitoring Results
Average Daily Flow (mgd)	0.38
Average Minimum Hourly Flow (mgd)	0.12
Average Maximum Hourly Flow (mgd)	0.55

Figure 5-4 shows flow contribution in each line from sewer modeling conducted in May 2014. These flows are being verified with monitoring currently underway. A small reduction in flow is expected with the increased focus on conservation in California due to the ongoing drought, however, many conservation measures target outdoor water use and therefore do not significantly affect flow available in the sewer.

Figure 5-4: District Collection System in Sharon Heights G&CC Area and Average Flow

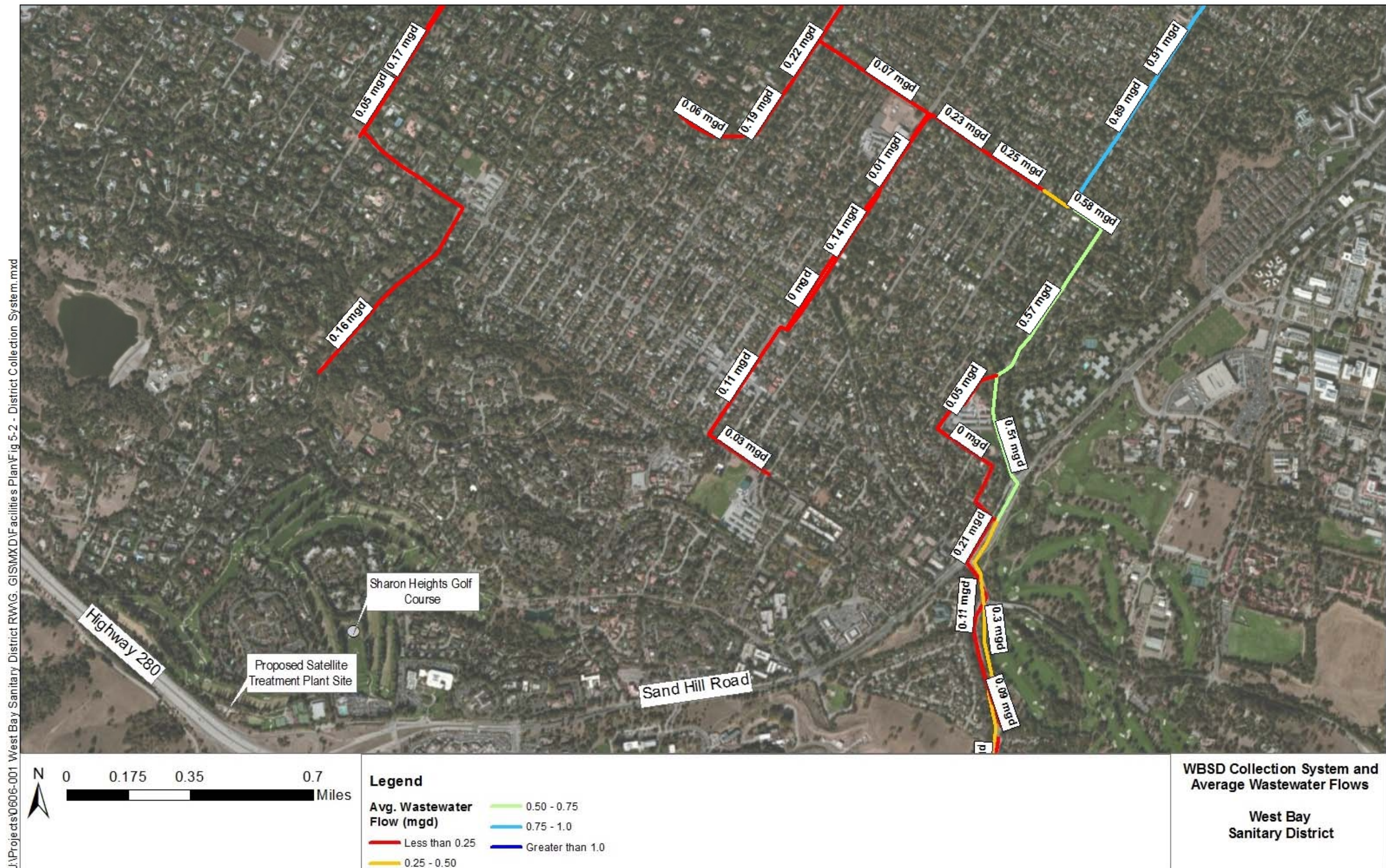

## Chapter 6 Treatment Requirements for Reuse

### 6.1 Recycled Water Treatment Requirements

Based on the target uses, the treatment facilities would need to meet Title 22 Disinfected Tertiary Recycled Water requirements. Table 6-1 summarizes the water quality requirements which varies depending on the type of filtration technology used.

The levels of constituents of concern to landscape irrigation and cooling tower customers within WBSD are not high enough to warrant additional treatment (e.g., advanced oxidation, reverse osmosis, etc.) beyond that required by Title 22 for “disinfected tertiary recycled water”.

**Table 6-1: Water Quality Requirements for Title 22 Disinfected Tertiary Recycled Water**

Process	Requirement
<b>Filtration Method</b>	
Coagulated <sup>1</sup> and passed through a bed of filter media	<ol style="list-style-type: none"> <li>1) Rate does not exceed 5 gallons per minute per square foot of surface area in mono, dual or mixed media gravity, upflow or pressure filtration systems</li> <li>1) Turbidity of the filtered wastewater does not exceed any of the following:               <ol style="list-style-type: none"> <li>a. An average of 2 NTU within a 24-hour period;</li> <li>b. 5 NTU more than 5 percent of the time within a 24-hour period; and</li> <li>c. 10 NTU at any time</li> </ol> </li> </ol>
Microfiltration, Ultrafiltration	<p>Turbidity does not exceed any of the following:</p> <ol style="list-style-type: none"> <li>1) 0.2 NTU more than 5 percent of the time within a 24-hour period; and</li> <li>2) 0.5 NTU at any time</li> </ol>
<b>Disinfection</b>	
UV	<ol style="list-style-type: none"> <li>2) A disinfection process that, when combined with filtration, has been demonstrated to achieve 5-log inactivation of virus</li> <li>3) The median concentration of total coliform bacteria measured in the disinfected effluent does not exceed a most probable number (MPN) of 2.2 per 100 milliliters utilizing the bacteriological results of the last seven days for which analyses have been completed and the number of total coliform bacteria does not exceed an MPN of 23 per 100 milliliters in more than one sample in any 30 day period. No sample shall exceed an MPN of 240 total coliform bacteria per 100 milliliters.</li> </ol>

Notes:

1. NTU: Nephelometric Turbidity Units

Footnotes:

1. Coagulation need not be used as part of the treatment process provided that the filter effluent turbidity does not exceed 2 NTU, the turbidity of the influent to the filters is continuously measured, the influent turbidity does not exceed 5 NTU for more than 15 minutes and never exceeds 10 NTU, and that there is the capability to automatically activate chemical addition or divert the wastewater should the filter influent turbidity exceed 5 NTU for more than 15 minutes.

### 6.2 Treatment Alternatives

The satellite treatment facility will need to include influent grit removal and screening to protect downstream equipment in addition to secondary treatment, filtration and disinfection to meet Title 22 disinfected tertiary recycled water requirements.

#### 6.2.1 Membrane Bioreactor

A membrane bioreactor (MBR) combines secondary treatment with ultrafiltration (UF) or microfiltration (MF) membranes (ranging in size from 0.01 to 0.4 micron) to produce a filtered effluent meeting recycled



water requirements. The secondary biological process of an MBR can be designed to meet a wide range to target water quality requirements including various nutrient water quality objectives (e.g., ammonia, total nitrogen, total phosphorous), and the membranes are provided, in lieu of secondary clarification to provide solids liquid separation. Figure 6-1 shows an example flow diagram for an MBR process.

**Figure 6-1: MBR Process Flow Diagram**

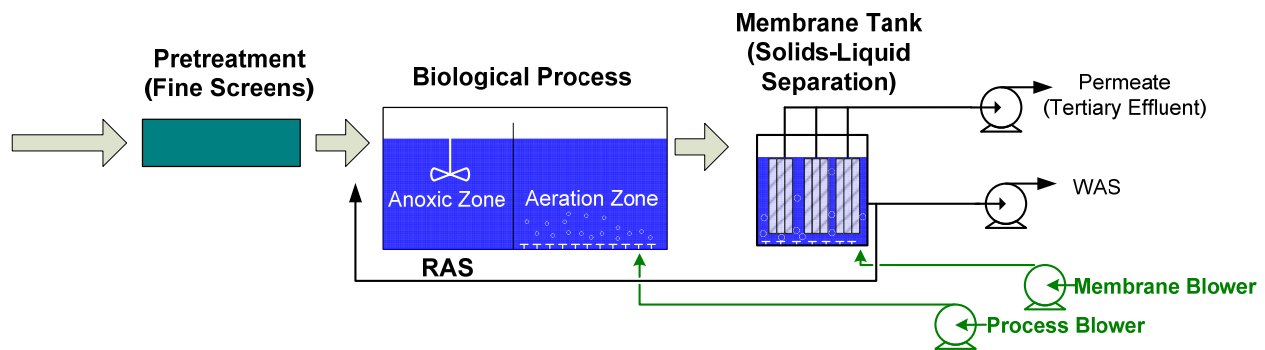

MBR facilities are advantageous when land is limited due to their compact footprint. By using membranes for solids-liquid separation, the MBR combines secondary clarification and tertiary filtration which reduces the facility footprint. Additionally, an MBR has the ability to operate at a higher mixed liquor concentration because solids liquid separation does not depend on gravity settling in a secondary clarifier.

An MBR membrane can either be a hollow fiber or flat plate membrane. Hollow fiber membrane systems typically require fine screening (2 mm screens or less) at the headworks for large and small debris removal (e.g. hair) that can foul and damage the membranes. The flat plate membranes do not typically require as fine of screen (3 mm or less) because the flat plate screens do not foul as easily. The screening requirements in front of the membranes vary by manufacturer.

MBR systems are typically designed with coarse bubble aeration in the membrane tanks. The purpose of the coarse bubble aeration is to provide agitation at the surface of the membrane and carry solids away from the membrane surface to minimize fouling and increase the permeability of the membrane. The coarse bubble aeration represents an additional aeration/energy demand of the MBR system.

Submerged membranes are subject to organic and inorganic fouling and are maintained by chemical cleaning. Typical chemicals include citric acid and sodium hypochlorite for organic and inorganic fouling, respectively. Maintenance cleaning is performed 1-2 times per week and includes the backpulse of chemical solution through the membranes. Recovery cleaning is performed 1-4 times per year and includes soaking the membranes in chemical solution.

The majority of municipal MBR systems in operation in the United States have the membranes submerged in the mixed liquor and permeate is either pulled through the membranes (vacuum pressure) or permeate is pushed through the membranes by gravity. MBR manufacturers with installations in California include GE/Zenon, Koch Membranes, Ovivo, and Evoqua. The specific sizing and operating details of an MBR system vary by manufacturer. Advantages and disadvantages of the MBR process are provided in Table 6-2.

**Table 6-2: Membrane Bioreactor Advantages and Disadvantages compared to a Sequencing Batch Reactor**

Advantages	Disadvantages
Compact footprint	High capital and operating costs associated with membrane maintenance and replacement
High quality tertiary effluent for recycled water use allows for lower UV dose for disinfection	Additional maintenance required for automated valve maintenance, compared with a Sequencing Batch Reactor (SBR)
Combines secondary treatment with tertiary treatment which minimizes facilities to operate	Requires fine screening upstream of the MBR, creating a larger solid stream to be disposed of
Eliminates operational issues associated with poor sludge settleability since MBRs do not rely on gravity settlement	

Figure 6-2 shows the process schematic for MBR treatment facilities including headworks, ultraviolet (UV) disinfection and effluent pumping.

**Figure 6-2: MBR Process Schematic**

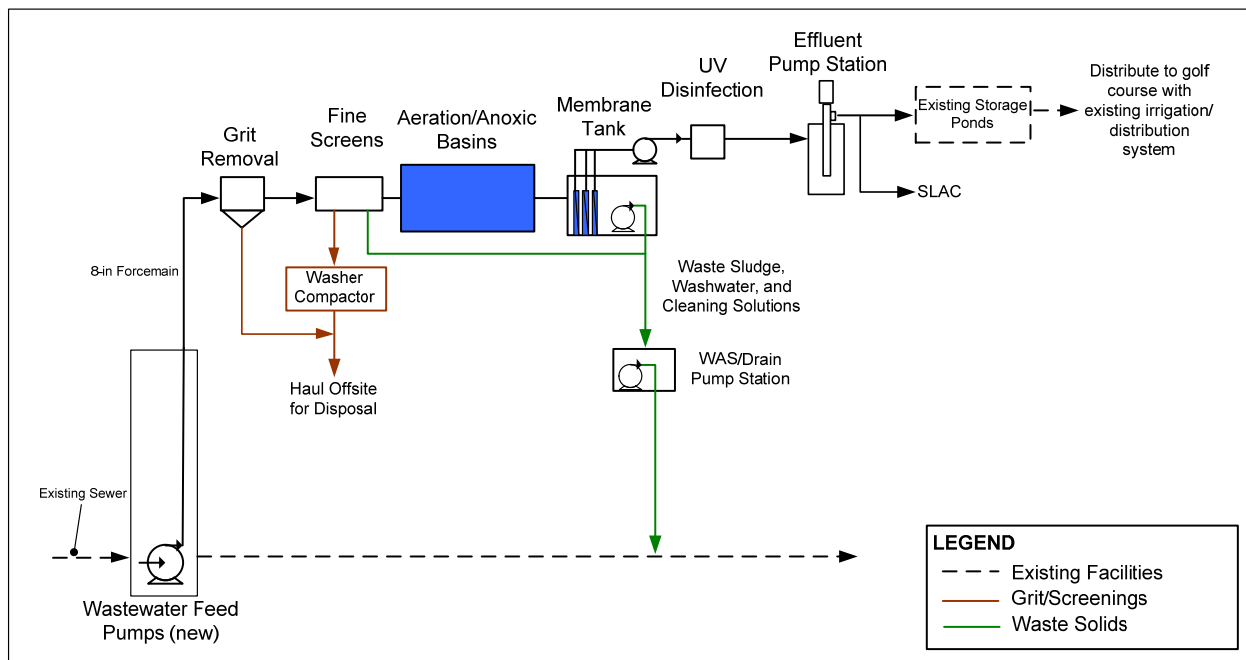

### 6.2.2 Sequencing Batch Reactor with Filtration

#### Sequencing Batch Reactor

A sequencing batch reactor (SBR) performs equalization, biological treatment, and secondary clarification in one basin versus separate basins for each process. The consolidation of processes allows for complete treatment on a small footprint and provides for potential capital cost savings by eliminating individual process tanks and equipment (clarifiers, etc.). A SBR facility would include two process trains to handle continuous wastewater flow.

A typical SBR process includes multiple operational modes including filling, reaction, settling, and decant. An advantage of SBR is that the reactor acts as an equalization basin as it fills such that peak flows can be absorbed without disrupting the treatment processes. Reactor filling has three variations

(static, mixed, aerated) that depend on the operating strategy, particularly the desired food to microorganism ratio and if aerobic or anoxic conditions are desired for nitrogen removal.

During the reaction mode, raw wastewater is mixed with biomass without aeration to achieve denitrification. The basin is then aerated to promote aerobic stabilization. During this aeration period biochemical oxygen demand (BOD) is consumed and ammonia is converted to nitrate.

The reaction process is followed by a settling period where biomass settles to the bottom of the tank. During this period excess biomass will be wasted from the SBR and would be discharged to the sewer.

Following the settling period, treated effluent is discharged from the basin through a decanter. Typical decanters include floating types and fixed types which vary by manufacturer. Floating decanters are generally preferred due to their operational flexibility. Manufacturers of SBR equipment include Sanitaire, Aqua Aerobics and Evoqua. Advantages and disadvantages of the SBR process are provided in Table 6-3.

**Table 6-3: SBR Advantages and Disadvantages Compared to MBR**

Advantages	Disadvantages
Simple process suitable for smaller sized facilities	May require more operational oversight to monitor sludge settleability
Lower capital and O&M costs than MBR facility	Need secondary effluent storage to equalize decant mode
Process is capable of producing tertiary effluent suitable for reuse	
Compact footprint	
Influent equalization built into process basin	

Figure 6-3 shows the process schematic for SBR facilities including headworks, filtration, UV disinfection and effluent pumping.

**Figure 6-3: SBR Process Schematic**

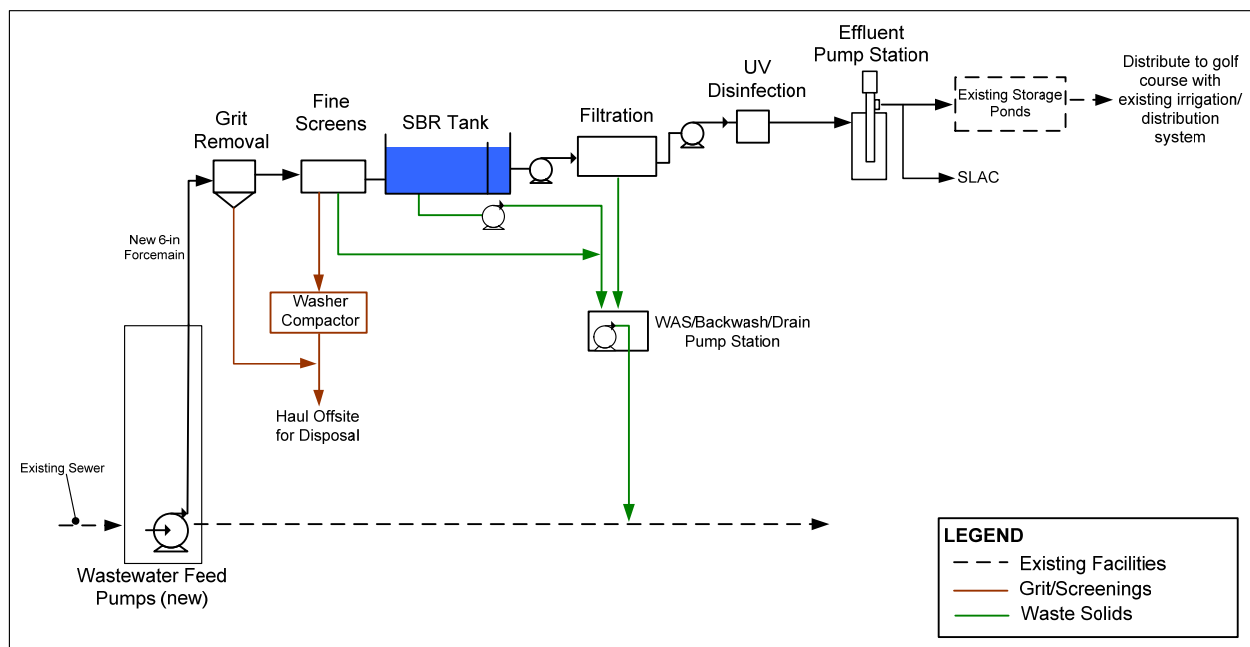

### Continuous Backwash Sand Filters

A continuous backwashing filter is an upflow granular media filter that provides continuous filtration while simultaneously backwashing the media and producing a side waste stream. As shown in Figure 6-4, filter influent enters the filter through a supply pipe that distributes the flow in an upward direction through the filter media. Ultimately, the filtered water flows over the effluent weir prior to flowing into the effluent discharge pipeline. While filtration is occurring, granular media is continuously extracted from the bottom of the filter and scoured with air and water. The washwater is captured and the media settles to the top of the filter bed. Key components of a continuous backwash sand filter include:

- Filter internal parts (including cone and central column)
- Sand media
- Air compressor system

**Figure 6-4: Continuous Backwash Sand Filter (Parkson Corporation DynaSand®)**

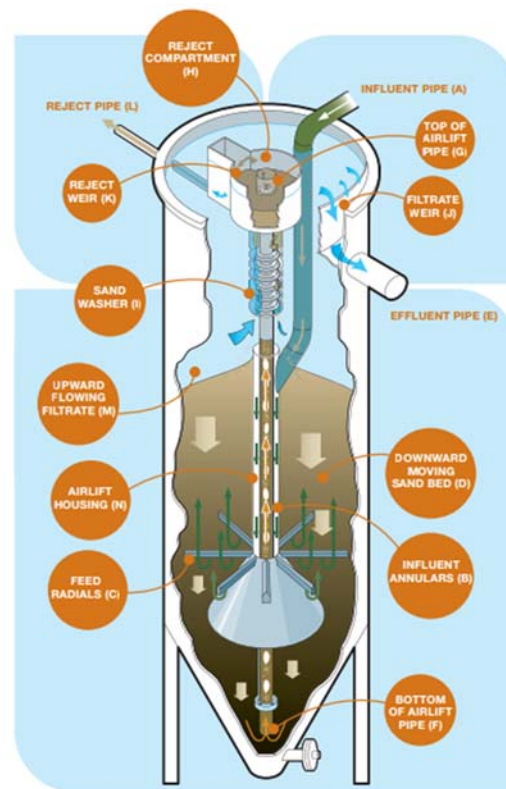

Several deep bed continuous backwash sand filters are Title 22-approved. The DynaSand filter is a proprietary upflow deep bed continuous backwash filter manufactured by the Parkson Corporation. The DynaSand is used in multiple Title 22 water reclamation projects across California. Other Title 22-approved continuous backwash filters include the SuperSand™ by WesTech, the Hydrasand by Andritz and the Centra-flo® by Blue Water Technologies. Advantages and disadvantages of continuous backwash sand filtration are summarized in Table 6-4.

**Table 6-4: Continuous Backwash Sand Filtration Evaluation**

Advantages	Disadvantages
Robust system compared to cloth media which can be subject to tearing	Higher headloss compared to cloth media filter
Continuous operation does not require stoppages for backwashing	Taller facility may create a visual impact
Compact footprint	Higher backwash rate (up to 10% of effluent flow) compared to cloth media filter

### Cloth Media Filtration

Cloth media filters utilize random weave fabric, nylon mesh or stainless steel mesh with nominal pore sizes ranging from 5 to 10 microns to filter particles from wastewater. There are currently eight cloth media filter manufacturers approved by the Department of Drinking Water (DDW) (formerly the Department of Public Health): Alfa Laval Ashbrook Simon-Hartley, Aqua-Aerobic Systems, Entex Technologies, Five Star Filtration, I. Kruger, Nordic Water, Sanitaire a Xylem Brand and Evoqua Water Technologies.

The configuration of each manufacturer's filter is unique; however the overall concept and treatment process are similar. In general, six pie-shaped sections of the filter media make up one disk, which is mounted vertically, along with other disks, on a tube inside a tank or basin. Tanks may be constructed out of concrete or stainless steel. Wastewater enters the tank or basin and passes by gravity through the cloth membrane. The solids accumulate on the cloth, forming a mat and causing the liquid levels within the basin to increase. Heavier solids settle to the bottom of the tank and are intermittently wasted. The filtered water enters the internal portion of the disk where it is discharged. The filters are designed to backwash automatically based upon a predetermined water level differential and are able to maintain constant filtration during backwash. The disks will only rotate during the backwash process, during which solids are backwashed from the surface of each disk by liquid suction from both sides of the disk. Key components of these filters include:

- Filter parts (including discs and center tube)
- Cloth media
- Drive system
- Backwash system

Figure 6-5 shows a general arrangement drawing for the Aqua Aerobic Systems AquaDisk® Cloth Media Filter. Filtration occurs as wastewater enters the basin or tank and passes through the cloth media. The filtered effluent enters the internal portion of the disk where it is directed to final discharge through the center shaft.

Figure 6-5: Cloth Media Filter (Aqua Aerobic Systems AquaDisk®)

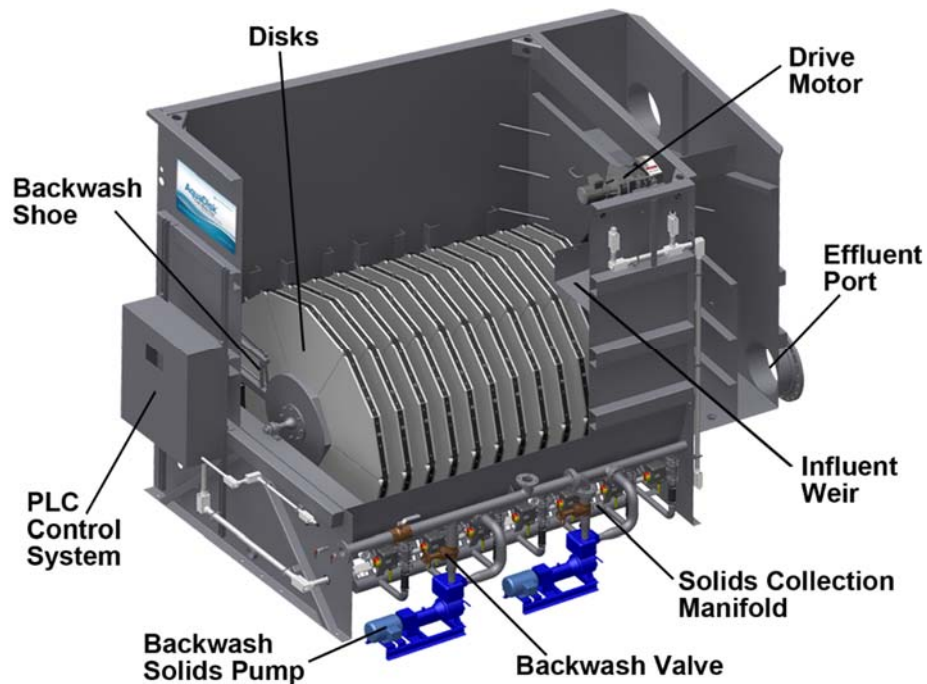

The AquaDisk® filter has been used for water reuse applications in California, with facilities in operation in Chiquita, Fort Irwin, Jackson Rancheria, Manteca, Merced, Moreno Valley, Perris Valley, San Bernardino, and Williams. Advantages and disadvantages of cloth media filtration are summarized in Table 6-5.

Table 6-5: Cloth Media Filtration Advantages and Disadvantages

Advantages	Disadvantages
Lower headloss than sand filters	Susceptible to tears in cloth resulting in filter down time
Continuous operation does not require stoppages for backwashing	Cost of media replacement
Compact footprint	
Modular design allows for additional disks to be added for additional capacity	

### 6.2.3 Disinfection Alternatives

Ultraviolet disinfection (UV) was selected as the disinfection process to minimize the footprint of the facility and minimize chemical transportation and delivery. A chlorine disinfection process would be the alternative and would require a much larger footprint and would require more chemical use and delivery.

During UV disinfection, filtered wastewater is passed through a closed vessel with lamps that emit UV light. Viruses and bacteria become deactivated upon exposure to high doses of UV energy at wavelengths between 250-270 nanometers (nm). The required UV design dose varies depending on the type of filtration process. For granular filters or cloth filters, the UV dose is 100 millijoules per square centimeter (mJ/cm<sup>2</sup>) and a UV transmittance of 55%. For membrane filtration the design dose is 80 mJ/cm<sup>2</sup> and a UV transmittance of 65%.

The most efficient type of UV system is the low-pressure, high intensity system. These systems emit a monochromatic light of 253.7 nm, the most effective wavelength for inactivation of bacteria and viruses. Lamps are typically controlled to generate a UV dose that is paced to the transmittance through the water (UV Transmittance, UVT) and flow rate. Performance of UV systems are usually affected by lamp age, degree of lamp fouling (reduced transmittance of UV light by biofilm, scaling, metal deposits on the lamp sleeve), and UVT. Lamp fouling is typically managed by an automated mechanical or mechanical/chemical cleaning of the UV lamp sleeves. UVT is measured by an on-line monitor, which can be input directly into a control loop and/or SCADA system

Major manufacturers of UV systems are Trojan Technologies Inc (Trojan), Infilco Degremont Inc (IDI), and Wedeco Inc (Wedeco). All three manufacturers supply low pressure, high intensity systems and have installations in California. UV systems typically include power distribution centers, system control centers, lamp ballasts, UV lamps and assemblies, interconnecting wiring, and in some cases a building to house the associated instrumentation and controls.

## Chapter 7 Project Alternatives

This Chapter documents the Project recycled water production assumptions, development of project alternatives and the process of determining the Recommended Project.

### 7.1 Planning and Design Assumptions

Table 7-1 summarizes design criteria used to size infrastructure for the various alternatives.

**Table 7-1: Facilities Development Criteria and Hydraulic Criteria**

Item	Value	Units/Notes
<b>Wastewater Pump Station</b>		
Pump Efficiency	75	%
Design Flow	Varies by Alternative	Peak Hour Demand (PHD)
<b>Wastewater Conveyance</b>		
Design Flow	Varies by Alternative	Peak Hour Demand (PHD)
Max Velocity for Sizing	5	ft/sec
C Coefficient for Headloss	130	(no units) Assuming PVC pipe
<b>Treatment</b>		
Treatment Capacity	Varies by Alternative	mgd
Solids Handling		Discharge to sewer
<b>Storage</b>		
No new recycled water storage is included in the alternatives. Sharon Heights Golf Course Storage of 2 MG would be used for Golf Course operations and to support delivery of water to the golf course over a 20 hour period.		
<b>Distribution Pump Station</b>		
Pump Efficiency	75	%
Design Flow	Varies by Alternative	Peak hour demand (PHD)
<b>Distribution Conveyance</b>		
Design Flow	Varies by Alternative	Peak hour demand (PHD)
Max Velocity for Sizing	5	ft/sec
C Coefficient for Headloss	130	(no units) Assuming PVC pipe
Delivery Pressure	75	psi

#### 7.1.1 Cost Estimate Basis

Cost estimates were prepared to evaluate and compare project alternatives and to support the alternative selection/decision process. The final costs of the project will depend on a variety factors, including but not limited to, actual labor and material costs, competitive market conditions, actual site conditions, final project scope, and implementation schedule.

The capital cost estimates for the alternatives were developed based other similar recycled water projects, cost quotations from treatment suppliers, industry publications, and typical pipeline installation costs in terms of cost per inch of pipeline length and inch diameter. Depending on the stage of the project and the level of detail understood, different estimating accuracies can be assumed. Since the Recycled Water Facility Plan is a preliminary planning phase project, these estimates are considered Class 5 estimates based on the AACE International Recommended Practice No. 18R-97, Cost Estimate Classification System – As Applied in Engineering, Procurement, and Construction for the Process Industries (2005). Class 5 estimates are based on a level of project definition of 0 to 2 percent and are suitable for alternatives analysis. The typical accuracy ranges for a Class 5 estimate is -20 to -50 percent on the low end, and +30 to +100 on the high end. In addition, the capital costs include the following contingency and markups:



- 30 percent construction contingency to account for unknown or unforeseen construction costs.
- Implementation costs allowances for environmental documentation, permits, design, construction management and financing.
- 5 percent project contingency to account for the current level of alternative detail.

Estimated costs are referenced to the April 2015 Engineering Construction Cost Index (ENR CCI) for San Francisco 11162.57.

O&M costs are the recurring annual expense to operate and maintain the facilities after construction is completed. The O&M cost elements include items such as power, operation and maintenance labor, and replacement of consumables (instruments, pumps, electrical equipment). The O&M cost estimates for the alternatives are developed based on similar recycled water projects, replacement equipment costs, industry publications, and pumping estimates. A contingency is not applied to O&M costs. Table 7-2 summarizes O&M cost assumptions.

**Table 7-2: O&M Cost Assumptions**

O&M Costs	Unit	Value
Equipment Consumables	-	2% of Equipment Costs
Electrical Consumables	-	2% of Electrical Costs
Instrumentation Consumables	-	2% of Instrumentation Costs
Pipeline Consumables	-	0.5% of Pipeline Costs
Power Costs	\$ per kwh	\$0.15
Labor Costs	\$ per hour	\$100

### 7.1.2 Unit Costs and Assumptions

Table 7-3 summarizes unit costs developed for common infrastructure for recycled water projects. Unit costs were developed based on RMC estimates from recent recycled water projects in California.

**Table 7-3: Construction Unit Costs**

Item	Unit Cost	Units/Notes
Pipelines		
6-inch diameter PVC	\$120	per LF (installed cost)
8-inch diameter PVC	\$160	per LF (installed cost)
10-inch diameter PVC	\$200	per LF (installed cost)
12-inch diameter PVC	\$240	per LF (installed cost)
Pump Stations <sup>1</sup>	\$6,500	hp (based on peak flow)

Footnotes:

1. Pump station unit cost includes all equipment (pumps, motors, variable frequency drives (VFDs), and electrical panels), building, and yard piping.

### Treatment Facilities Costs

Treatment equipment costs were developed based on the following sources:

- Project specific equipment vendor quotes – For the major treatment processes, MBR, SBR, cloth media filtration and granular media filtration, RMC coordinated with vendors (GE/Zenon for MBR, Sanitaire for SBR and Five Star Filtration for filtration options) to get project-specific budget quotes for the various capacities included in the conceptual projects.

- Previous project experience – RMC has recent project experience planning and designing several aspects of the treatment systems included in the conceptual projects, including MBR, concrete construction, headworks, UV disinfection, pumps, mixers, and blowers, and other items. These previous examples were used to estimate the unit costs included in this planning level estimate.
- Preliminary process sizing and layouts –Process facilities were preliminary sized and a preliminary layout was developed to identify space needed for the treatment plant and to develop quantities for the cost estimate (e.g., concrete, excavation, etc.).

### Capital Financing Assumptions

The State Water Resource Control Board (SWRCB) Clean Water State Revolving Fund (SRF) offers low interest financing for recycled water projects. The SRF program offers 30-year financing at an interest rate of ½ the most recent General Obligation (GO) Bond Rate at time of funding approval. The interest rate has ranged from 1.7% to 3.0% over the last 10 years.

SRF financing assumptions used to annualize capital costs are:

- Annual Interest rate - 2.0%
- Term of Financing - 30 years

The rates for SRF financing does change based on the current market conditions, so actually project financing rate will likely differ from the assumption above.

## 7.2 Recycled Water Project Alternatives

Based on the results from the market assessment and proximity analysis, three Project Alternatives were developed and evaluated:

- **Alternative A, also referred to as Baseline Project**, which would serve Sharon Heights G&CC only whose demand was considered large enough to constitute a project on its own. This Project was developed based on information from the Market Survey, and through consultation with the WBSD and Sharon Heights G&CC. In Alternative A, WBSD would install recycled water treatment facilities at the golf course to serve only the demand from Sharon Heights G&CC.
- **Alternative B, also referred to as Baseline plus SLAC Project**, which would serve Sharon Heights G&CC and the irrigation and cooling tower demands of SLAC.
- **Alternative C, also referred to as Baseline plus Other Users Project**, which would serve Sharon Heights G&CC, Sharon Land Co., Sand Hill Commons and Rosewood Sand Hill.

The three alternatives are discussed in the following sections. MBR treatment and SBR with granular media filtration are compared for each Alternative.

### 7.2.1 Alternative A – Baseline Project

Alternative A is the Baseline Project and involves the construction of satellite treatment facilities, a wastewater pump station and forcemain to divert flow to the treatment facility and a solids discharge pipeline to convey waste sludge to an existing WBSD sewer. Grit and screenings would be collected in a dumpster and hauled offsite for disposal. Table 7-4 summarizes the customers and demands served by Alternative A. Table 7-5 summarizes the facilities needed for Alternative A.

For this Alternative, Sharon Heights G&CC is the sole targeted user. Sharon Heights G&CC is interested in implementing this project on a short time schedule. Distributing recycled water from the satellite plant would require the City of Menlo Park to allow WBSD to be the recycled water distributor within the City's water service area. Menlo Park has expressed support of this action.

Table 7-4: Alternative A Users

Customer Name	Type of Use	Average Annual Demand (AFY)	Max Day Demand (mgd)	Peak Hour Demand (gpm)
Sharon Heights Golf & Country Club	Irrigation	152	0.4	839

Table 7-5: Alternative A Main Facilities

Component	MBR			SBR + Granular Media Filtration		
	Value	Units	Notes	Value	Units	Notes
Influent Pump Station						
Design Flow	0.8	mgd	Peak hour wastewater flow	0.8	mgd	Peak hour wastewater flow
No. of Pumps	2	-	1 Duty, 1 Standby	2	-	1 Duty, 1 Standby
TDH	300	ft		300	ft	
hp per Pump	45	hp		45	hp	
Influent Pipeline						
8" Pipe	10,560	LF		10,560	LF	
Treatment Facilities						
Grit Removal	0.8	mgd		0.8	mgd	
Fine Screens	2	mm		3	mm	
MBR System – Biological Trains	2	-		N/A		
MBR System Flow	0.4	mgd	Max day wastewater flow			
MBR System – Membrane Tanks	2	-	Two cassettes per tank	N/A		
SBR System Flow				0.4	mgd	Max day wastewater flow
SBR System – Trains	N/A			2	-	
UV Disinfection	0.4	mgd		0.4	mgd	
Solids Discharge Pipeline						
6" Pipe	1,580	LF		1,580	LF	
Distribution Pump Station to Storage Ponds						
Design Flow	1.2	mgd	Peak hour irrigation demand	1.2	mgd	Peak hour irrigation demand
No. of Pumps	2	-		2	-	
TDH	30	ft		30	ft	
hp per Pump	10	hp		10	hp	

### Pipeline Critical Crossings

Alternative A requires one major crossing – an east to west crossing of the Hetch-Hetchy right-of-way by the influent forcemain. Utilities crossing SFPUC pipelines must have a minimum clearance of 12-inches for open excavation, 24-inches for directional boring operation. All crossings must be as close to perpendicular as possible. All sewer and recycled water crossings must comply with Division of Drinking Water (DDW) requirements:

- When a sewage forcemain must cross a water main, the crossing should be as close as practical to the perpendicular. The sewage force main should be at least one foot below the water main.
- When a new sewage forcemain crosses under an existing water main, and a one-foot vertical separation cannot be provided, all portions of the sewage force main within eight feet

(horizontally) of the outside walls of the water main should be enclosed in a continuous sleeve. In these cases, a minimum vertical separation distance of 4 inches should be maintained between the outside edge of the bottom of the water main and the top of the continuous sleeve.

### **Treatment Facilities**

Based on discussions with Sharon Heights G&CC, a section of the golf course near Highway 280 is undeveloped and available for the satellite treatment plant. The influent pump station will be sized to pump the peak hour available wastewater flow of 0.8 mgd. The satellite plant would be sized to treat the max day demand flow of 0.4 mgd. Because the facility would operate as a dry weather satellite plant, it is assumed that it would operate at a constant flow rate over 24 hours a day for 8 months of the year and operate at half capacity for 4 months of wet weather to maintain the biological processes.

Irrigation demands were assumed to occur over an 8-hour period. Storage would be provided for recycled water that is produced during the times when there is no demand (e.g. during the 12 to 16-hour window when irrigation demands do not occur) at the existing two million gallon golf course reservoir located near Sharon Park Drive. It was assumed that existing pipeline will be utilized to convey recycled water to the reservoir.

Raw wastewater would be pumped from a new manhole at Oak Avenue and Sand Hill Road which would divert flow from the existing 36-inch sewer to the satellite treatment plant. It was assumed that grit and screenings produced at the facility would be washed, compacted and hauled offsite for disposal and that waste sludge would be discharged by gravity to an existing 8-inch sewer lateral running along the southwest boundary of the golf course to be conveyed to SVCW. Headworks facilities (screening and grit removal) and biological tanks would have an odor control system. Biological tanks would be constructed below grade.

Table 7-6: Alternative A Cost Estimate

Description	MBR	SBR + Granular Media Filtration
Influent Pump Station	\$614,000	\$614,000
Influent Pipeline	\$1,774,000	\$1,774,000
Treatment Facilities	\$6,768,000	\$5,643,000
Distribution Pump Station	\$375,000	\$375,000
Distribution Pipeline		
<b>Raw Construction Cost</b>	<b>\$9,351,000</b>	<b>\$8,406,000</b>
Construction Contingency (30% of Raw Construction Cost)	\$2,859,000	\$2,522,000
<b>Total Construction Cost</b>	<b>\$12,390,000</b>	<b>\$10,928,000</b>
Implementation Cost	\$2,600,000	\$2,600,000
Project Contingency (5% of Total Construction Cost)	\$620,000	\$547,000
<b>Total Capital Cost</b>	<b>\$15,610,000</b>	<b>\$14,075,000</b>
Annualized Capital Costs <sup>1</sup>	\$697,000	\$628,000
Annual O&M Costs	\$233,000	\$198,000
Total Annualized Cost <sup>2</sup>	\$930,000	\$826,000
Estimated Recycled Water Yield (AFY)	152	152
<b>Unit Cost, Annualized (\$/AFY)</b>	<b>\$6,100</b>	<b>\$5,400</b>

Footnotes:

1. Planning level estimate; costs are in April 2015 dollars
2. Annualized at 30 years, 2.0%

### 7.2.2 Alternative B – Baseline Project Plus SLAC

Alternative B involves the same facilities as Alternative A with the addition of a recycled water distribution pipeline and pump station to deliver water to SLAC. Table 7-7 summarizes the demands served by Alternative B. Table 7-8 summarizes the facilities needed for Alternative B.

SLAC was targeted as a user for Alternative B because of its cooling tower and irrigation demands and proximity to Sharon Heights G&CC. The recycled water demand for Sharon Heights G&CC alone is relatively low (152 AFY) for a new satellite treatment plant. Including SLAC as a user would increase the overall recycled water project yield and decrease the unit cost of recycled water. Preliminary wastewater flow monitoring at the proposed influent pump station location has indicated inadequate flows to meet SLAC's irrigation and cooling tower demand year-round in addition to Sharon Heights G&CC's demands. Therefore, it is assumed that SLAC will be served for seven months of the year from approximately October to April.

Table 7-7: Alternative B Users

Customer Name	Type of Use	Average Annual Demand (AFY)	Max Day Demand (mgd)	Peak Hour Demand (gpm)
Sharon Heights Golf & Country Club	Irrigation	152	0.4	839
SLAC	Irrigation	25 <sup>1</sup>	0.11	237
SLAC	Cooling Tower	59 <sup>1</sup>	0.18	213

Footnotes:

1. Based on assumed seven months of recycled water delivery.

**Table 7-8: Alternative B Main Facilities**

Component	MBR			SBR + Granular Media Filtration		
	Value	Units	Notes	Value	Units	Notes
<b>Influent Pump Station</b>						
Design Flow	0.8	mgd	Peak hour wastewater flow	0.8	mgd	Peak hour wastewater flow
No. of Pumps	2	-	1 Duty, 1 Standby	2	-	1 Duty, 1 Standby
TDH	300	ft		300	ft	
hp per Pump	45	hp		45	hp	
<b>Influent Pipeline</b>						
8" Pipe	10,560	LF		10,560	LF	
<b>Treatment Facilities</b>						
Grit Removal	0.8	mgd		0.8	mgd	
Fine Screens	2	mm		3	mm	
MBR System – Biological Trains	2	-		N/A		
MBR System Flow	0.5	mgd	Max day wastewater flow			
MBR System – Membrane Tanks	2	-	Two cassettes per tank	N/A		
SBR System Flow				0.5	mgd	Max day wastewater flow
SBR System – Trains	N/A			2	-	
UV Disinfection	0.5	mgd	Max day wastewater flow	0.5	mgd	Max day wastewater flow
<b>Solids Discharge Pipeline</b>						
6" Pipe	1,580	LF		1,580	LF	
<b>Distribution Pump Station to Storage Ponds</b>						
Design Flow	1.2	mgd	Peak hour irrigation demand	1.2	mgd	Peak hour irrigation demand
No. of Pumps	2	-		2	-	
TDH	30	ft		30	ft	
hp per Pump	10	hp		10	hp	
<b>Distribution Pump Station to SLAC</b>						
Design Flow	0.34	mgd	Peak hour irrigation demand	0.34	mgd	Peak hour irrigation demand
No. of Pumps	2	-	1 Duty, 1 Standby	2	-	1 Duty, 1 Standby
TDH	240	ft		240	ft	
hp per Pump	20	hp		20	hp	
Discharge Pressure	70	psi		70	psi	
<b>Distribution Pipeline to SLAC</b>						
6" Pipe	5,300	LF		5,300	LF	

**Pipeline Critical Crossings**

There are no critical crossings in addition to the crossings for Alternative A discussed in Section 7.2.1.

### Treatment Facilities

The influent pump station will be sized to pump the peak hour available wastewater flow of 0.8 mgd. The satellite plant would be sized to treat the max day available wastewater flow of 0.5 mgd.

In addition to the treatment facilities described for Alternative A, Alternative B will include a recycled water distribution pipeline and pump station to convey recycled water to SLAC. It is assumed that SLAC will provide its own on-site storage facilities.

**Table 7-9: Alternative B Cost Estimate**

Description	MBR	SBR + Granular Media Filtration
Influent Pump Station	\$614,000	\$614,000
Influent Pipeline	\$1,774,000	\$1,774,000
Treatment Facilities	\$6,768,000	\$5,699,000
Distribution Pump Station	\$454,000	\$454,000
Distribution Pipeline	\$665,000	\$665,000
<b>Raw Construction Cost</b>	<b>\$10,275,000</b>	<b>\$9,207,000</b>
Construction Contingency (30% of Raw Construction Cost)	\$3,083,000	\$2,762,000
<b>Total Construction Cost</b>	<b>\$13,358,000</b>	<b>\$11,969,000</b>
Implementation Cost	\$3,100,000	\$3,100,000
Project Contingency (5% of Total Construction Cost)	\$668,000	\$599,000
<b>Total Capital Cost</b>	<b>\$17,126,000</b>	<b>\$15,668,000</b>
Annualized Capital Costs <sup>1</sup>	\$765,000	\$700,000
Annual O&M Costs	\$258,000	\$219,000
Total Annualized Cost <sup>2</sup>	\$1,023,000	\$919,000
Estimated Recycled Water Yield (AFY)	236	236
<b>Unit Cost, Annualized (\$/AFY)</b>	<b>\$4,300</b>	<b>\$3,900</b>

Footnotes:

1. Planning level estimate; costs are in April 2015 dollars
2. Annualized at 30 years, 2.0%

### **7.2.3 Alternative C – Baseline Project Plus Other Users**

Alternative C involves the same facilities as Alternative A with the addition of a recycled water distribution pipeline and pump station to deliver water to Sharon Land Co., Sand Hill Commons and the Rosewood Sand Hill. Table 7-10 summarizes the customers and demands served by Alternative C. Table 7-11 summarizes the facilities needed for Alternative C.

Sharon Land Co., Sand Hill Commons and the Rosewood Sand Hill were targeted as users for Alternative C because of their proximity to Sharon Heights G&CC and combined demand. The recycled water demand for Sharon Heights G&CC alone is relatively low (152 AFY) for a new satellite treatment plant and including the three additional users would increase the overall recycled water project yield and decrease the unit cost of recycled water.



Table 7-10: Alternative C Users

Customer Name	Type of Use	Average Annual Demand (AFY0)	Max Day Demand (mgd)	Peak Hour Demand (gpm)
Sharon Heights Golf & Country Club	Irrigation	152	0.4	839
Sharon Land Co.	Irrigation	10	0.03	53
Sand Hill Commons	Irrigation	11	0.03	61
Rosewood Sand Hill	Irrigation	24	0.06	135

Table 7-11: Alternative C Main Facilities

Component	MBR			SBR + Granular Media Filtration		
	Value	Units	Notes	Value	Units	Notes
Influent Pump Station						
Design Flow	0.8	mgd	Peak hour wastewater flow	0.8	mgd	Peak hour wastewater flow
No. of Pumps	2	-	1 Duty, 1 Standby	2	-	1 Duty, 1 Standby
TDH	300	ft		300	ft	
hp per Pump	45	hp		45	hp	
Influent Pipeline						
8" Pipe	10,560	LF		10,560	LF	
Treatment Facilities						
Grit Removal	0.8	mgd		0.8	mgd	
Fine Screens	2	mm		3	mm	
MBR System – Biological Trains	2	-		N/A		
MBR System Flow	0.5	mgd	Max day wastewater flow			
MBR System – Membrane Tanks	2	-	Two cassettes per tank	N/A		
SBR System Flow				0.5	Mgd	Max day wastewater flow
SBR System – Trains	N/A			2	-	
UV Disinfection	0.5	mgd		0.5	mgd	
Solids Discharge Pipeline						
6" Pipe	1,580	LF		1,580	LF	
Distribution Pump Station to Storage Ponds						
Design Flow	1.2	mgd	Peak hour irrigation demand	1.2	mgd	Peak hour irrigation demand
No. of Pumps	2	-		2	-	
TDH	30	ft		30	ft	
hp per Pump	10	hp		10	hp	
Distribution Pump Station to Other Users						
Design Flow	0.3	mgd	Peak hour irrigation demand	0.3	mgd	Peak hour irrigation demand
No. of Pumps	2	-	1 Duty, 1 Standby	2	-	1 Duty, 1 Standby
TDH	210	ft		210	ft	
hp per Pump	15	hp		15	hp	
Discharge Pressure	70	psi		70	psi	

Component	MBR			SBR + Granular Media Filtration		
	Value	Units	Notes	Value	Units	Notes
Distribution Pipeline						
6" Pipe	6,400	LF		6,400	LF	

### Pipeline Critical Crossings

There are no critical crossings in addition to the crossings for Alternative A discussed in Section 7.2.1.

### Treatment Facilities

The influent pump station will be sized to pump the peak hour available wastewater flow of 0.8 mgd. The satellite plant would be sized to treat the max day available wastewater flow of 0.5 mgd to serve Sharon Heights G&CC, Sharon Land Co., Sand Hill Commons and Rosewood Sand Hill.

In addition to the treatment facilities described for Alternative A, Alternative C will include a recycled water distribution pipelines and pump station.

**Table 7-12: Alternative C Cost Estimate**

Description	MBR	SBR + Granular Media Filtration
Influent Pump Station	\$614,000	\$614,000
Influent Pipeline	\$1,774,000	\$1,774,000
Treatment Facilities	\$6,768,000	\$5,699,000
Distribution Pump Station	\$454,000	\$454,000
Distribution Pipeline	\$798,000	\$798,000
<b>Raw Construction Cost</b>	<b>\$10,408,000</b>	<b>\$9,340,000</b>
Construction Contingency (30% of Raw Construction Cost)	\$3,122,000	\$2,802,000
<b>Total Construction Cost</b>	<b>\$13,530,000</b>	<b>\$12,142,000</b>
Implementation Cost	\$3,000,000	\$3,000,000
Project Contingency (5% of Total Construction Cost)	\$677,000	\$607,000
<b>Total Capital Cost</b>	<b>\$17,207,000</b>	<b>\$15,749,000</b>
Annualized Capital Costs <sup>1</sup>	\$768,000	\$703,000
Annual O&M Costs	\$248,000	\$210,000
Total Annualized Cost <sup>2</sup>	\$1,016,000	\$913,000
Estimated Recycled Water Yield (AFY)	197	197
<b>Unit Cost, Annualized (\$/AFY)</b>	<b>\$5,200</b>	<b>\$4,600</b>

Footnotes:

1. Planning level estimate; costs are in April 2015 dollars
2. Annualized at 30 years, 2.0%

### **7.2.4 Alternatives Comparison**

Table 7-13 summarizes the advantages and disadvantages between MBR and SBR with granular media filtration and the costs between the three Alternatives. Figure 7-1 shows the locations of the major facilities for the three alternatives.

Table 7-13: Alternatives Comparison

Description	MBR	SBR + Granular Media Filtration
<b>Advantages</b>	<ul style="list-style-type: none"> <li>• Compact footprint</li> <li>• High quality tertiary effluent for recycled water use and discharge during wet weather season</li> <li>• Combines secondary treatment with tertiary treatment which minimizes facilities to operate</li> <li>• Eliminates operational issues associated with poor sludge settleability since MBRs do not rely on gravity sedimentation</li> </ul>	<ul style="list-style-type: none"> <li>• Compact footprint</li> <li>• Process is capable of producing tertiary effluent suitable for reuse</li> <li>• Simple process suitable for smaller sized facilities</li> <li>• Lower capital and O&amp;M costs than MBR facility</li> </ul>
<b>Disadvantages</b>	<ul style="list-style-type: none"> <li>• High capital and operating costs associated with membrane maintenance and replacement</li> <li>• Additional maintenance required for automated valve maintenance, compared with an SBR</li> <li>• Requires fine screening upstream of the MBR, creating a solids stream to be disposed of</li> </ul>	<ul style="list-style-type: none"> <li>• May require more operational oversight to monitor sludge settleability</li> </ul>
<b>Alternative A</b>		
Total Capital Cost	<b>\$15,610,000</b>	<b>\$14,020,000</b>
Annual O&M Costs	\$233,000	\$197,000
Total Annualized Cost	\$930,000	\$823,000
Estimated Recycled Water Yield (AFY)	152	152
Unit Cost, Annualized (\$/AFY)	<b>\$6,100</b>	<b>\$5,400</b>
<b>Alternative B</b>		
Total Capital Cost	<b>\$17,126,000</b>	<b>\$15,668,000</b>
Annual O&M Costs	\$258,000	\$219,000
Total Annualized Cost	\$1,023,000	\$919,000
Estimated Recycled Water Yield (AFY)	236	236
Unit Cost, Annualized (\$/AFY)	<b>\$4,300</b>	<b>\$3,900</b>
<b>Alternative C</b>		
Total Capital Cost	<b>\$17,207,000</b>	<b>\$15,749,000</b>
Annual O&M Costs	\$248,000	\$210,000
Total Annualized Cost	\$1,016,000	\$913,000
Estimated Recycled Water Yield (AFY)	197	197
Unit Cost, Annualized (\$/AFY)	<b>\$5,200</b>	<b>\$4,600</b>

Figure 7-1: Alternatives Major Facilities

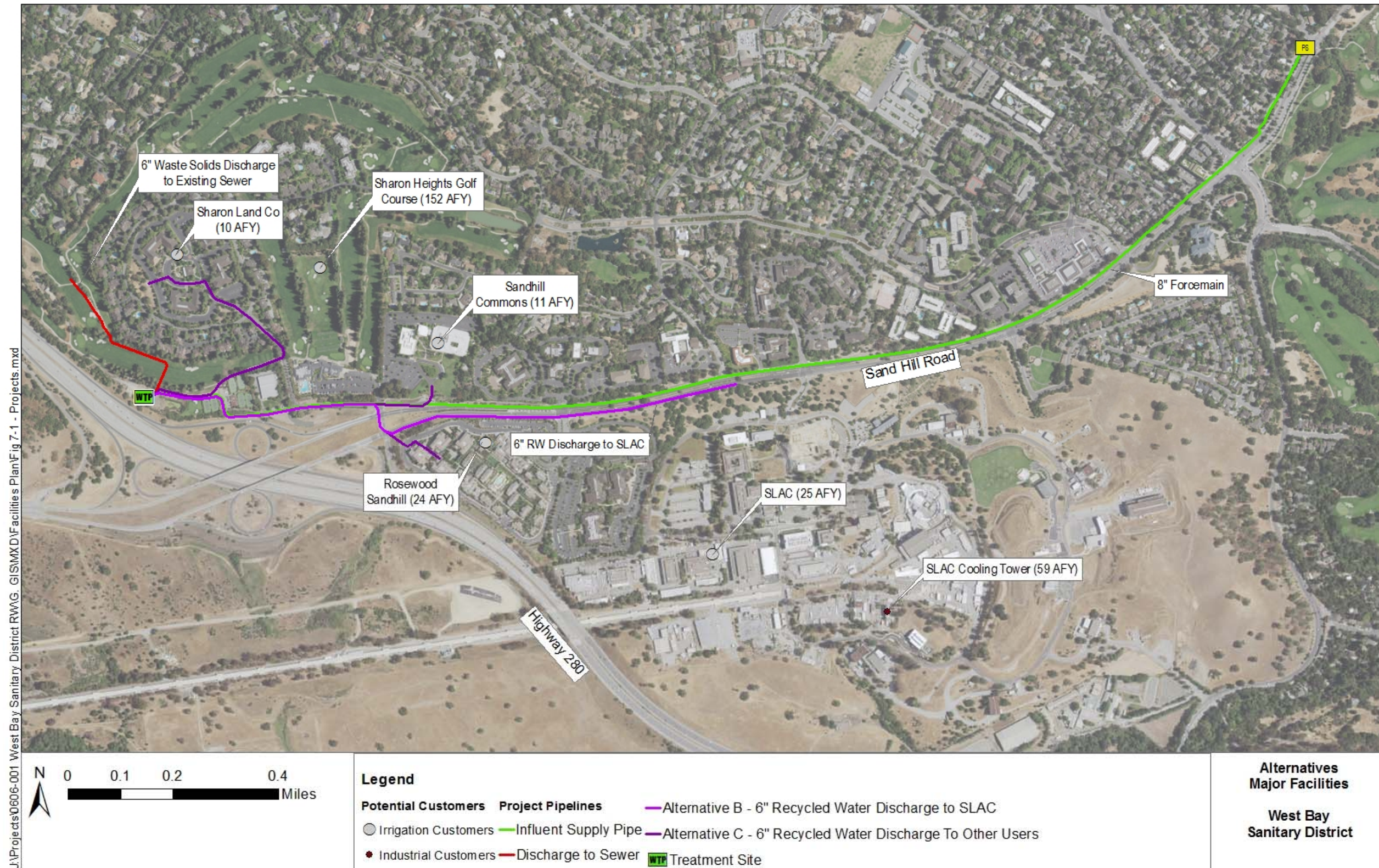

## **Conclusions**

Based on discussions with WBSD, Alternative B was recommended:

- Incremental construction cost of \$1,556,000 compared to the Baseline Project would bring an additional 144 AFY of recycled water use.
- Compared to SBR, MBR provides high quality tertiary effluent for recycled water use
- MBR eliminates operational issues associated with poor sludge settleability since MBRs do not rely on gravity sedimentation
- Includes a year-round demand

## Chapter 8 Recommended Project

This chapter describes the Recommended Recycled Water Project (Recommended Project) and includes target customers, project facilities descriptions, cost estimates, project benefits and an implementation plan (including construction financing plan).

### 8.1 Facilities

The Recommended Project involves the construction of satellite treatment facilities designed to treat a max day flow of 0.5 mgd, a wastewater pump station to divert flow to the treatment facility, 1,580 LF of pipeline to discharge solids to an existing sewer, and 5,300 LF of distribution pipeline to SLAC. The Project would deliver an estimated 236 AFY of recycled water, including 152 AFY to Sharon Heights G&CC through the year and approximately 84 AFY over seven months to SLAC for irrigation and cooling tower uses. Table 8-1 provides the estimated average annual demand for each customer.

**Table 8-1: Recommended Project Recycled Water Customers**

Customer Name	Primary Type of Use	Average Annual Demand (AFY)	Max Day Demand (mgd)	Peak Hour Demand (gpm)
Sharon Heights Golf Course	Golf Course Irrigation	152	0.4	839
SLAC	Irrigation	25 <sup>1</sup>	0.11	237
SLAC	Cooling Tower	59 <sup>1</sup>	0.18	213

Footnotes:

1. Based on assumed seven months of recycled water delivery.

The Project begins with diverting wastewater flow from the 36-inch sewer at the intersection of Sand Hill and Oak Avenue. Wastewater would be pumped to Sharon Heights G&CC along Sand Hill Road through an Influent Pump Station where it arrives at the Satellite Treatment Facility. At the treatment facility, the first step is grit removal and fine screening (2 mm fine screen). The screened wastewater will then flow to biological reactor tanks, MBR treatment system, through a UV disinfection unit and to a recycled water clearwell. The recycled water clearwell would be used as the distribution pump station for SLAC and to deliver recycled water to the two million gallon Sharon Heights G&CC storage pond.

Figure 8-1 illustrates the recommended, planning-level layout for the new recycled water treatment facilities at Sharon Heights.

Distribution from the satellite plant to SLAC will be through one 6-inch pipeline. Grit and screenings will be collected in a common dumpster and hauled offsite for disposal. Solids produced from the MBR system will be discharged by gravity through a 6-inch pipeline to an existing 8-inch sewer lateral located near the southwest boundary of the golf course.

Figure 8-2 illustrates the recommended recycled water target customers and major facilities. Figure 8-3 illustrates the influent pump station configuration.

Figure 8-1: Recommended Project Facility-Planning Level Satellite Treatment Layout



Figure 8-2: Recommended Project Recycled Water Customers and Facilities

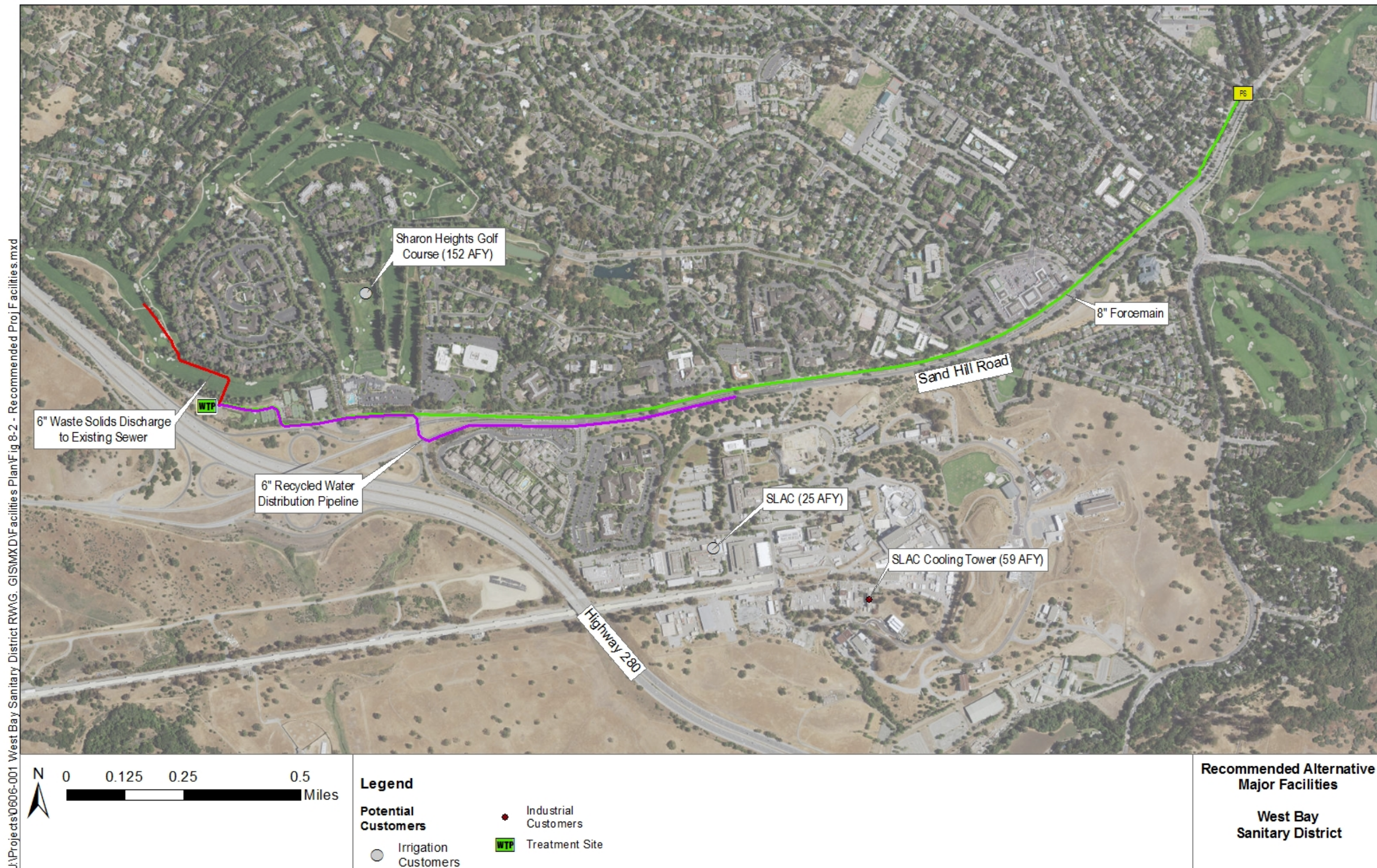



Figure 8-3: Influent Pump Station Configuration



Table 8-2 is a summary of key planning-level design criteria for the recommended facilities.

**Table 8-2: Design Criteria for Recommended Project**

Component	MBR		
	Value	Units	Notes
<b>Influent Pump Station</b>			
Design Flow	0.8	mgd	Peak hour wastewater flow
No. of Pumps	2	-	1 Duty, 1 Standby
TDH	300	ft	
hp per Pump	45	hp	
<b>Influent Pipeline</b>			
8" Pipe	10,560	LF	
<b>Treatment Facilities</b>			
Grit Removal	0.8	mgd	
Fine Screens	2	mm	
MBR System – Biological Trains	2	-	
MBR System Flow	0.5	mgd	Max day wastewater flow
MBR System – Membrane Tanks	2	-	Two cassettes per tank
SBR System Flow			
SBR System – Trains	N/A		
UV Disinfection	0.5	mgd	Max day wastewater flow
<b>Solids Discharge Pipeline</b>			
6" Pipe	1,580	LF	
<b>Distribution Pump Station to Storage Ponds</b>			
Design Flow	1.2	mgd	Peak hour irrigation demand
No. of Pumps	2	-	
TDH	30	ft	
hp per Pump	10	hp	
<b>Distribution Pump Station to SLAC</b>			
Design Flow	0.34	mgd	Peak hour irrigation demand
No. of Pumps	2	-	1 Duty, 1 Standby
TDH	240	ft	
hp per Pump	20	hp	
Discharge Pressure	70	psi	
<b>Distribution Pipeline</b>			
6" Pipe	5,300	LF	

## 8.2 Recommended Project Cost Estimate

Table 8-3 summarizes the estimated cost for the Recommended Project. See Appendix D for detailed cost information.

Table 8-3: Recommended Project Costs (April 2015 Dollars)

Description	MBR Facility Cost	Treatment
Influent Pump Station	\$614,000	
Influent Pipeline	\$1,774,000	
Treatment Facilities	\$6,768,000	
Distribution Pump Station	\$454,000	
Distribution Pipeline	\$665,000	
<b>Raw Construction Cost</b>	<b>\$10,275,000</b>	
Construction Contingency (30% of Raw Construction Cost)	\$3,064,000	
<b>Total Construction Cost</b>	<b>\$13,358,000</b>	
Implementation Cost	\$3,100,000	
Project Contingency (5% of Total Construction Cost)	\$668,000	
<b>Total Capital Cost</b>	<b>\$17,126,000</b>	
Annualized Capital Costs <sup>1</sup>	\$765,000	
Annual O&M Costs	\$258,000	
Total Annualized Cost <sup>2</sup>	\$1,023,000	
Estimated Recycled Water Yield (AFY)	236	
<b>Unit Cost, Annualized (\$/AFY)</b>	<b>\$4,300</b>	

Footnotes:

1. Planning level estimate; costs are in April 2015 dollars
2. Annualized at 30 years, 2.0%

### 8.3 Comparison to No Project Alternative (SFPUC Supply)

Without the Project, existing demands would continue to be met using SFPUC supply through the MPMWD. Table 8-4 is a comparison between the Recommended Recycled Water Project and the No Project Alternative (continued use of SFPUC water for irrigation).

**Table 8-4: Recommended Recycled Water Project vs. No Project Alternative (SFPUC Supply)**

Criteria	Recommended Recycled Water Project	No Project –Continued SFPUC Supply
<b>Summary</b>		
Description	Development of treatment and distribution systems to provide recycled water for irrigation and cooling tower use	Status quo. No additional facilities required.
Water Supply	Recycled water from the Sharon Heights Satellite Treatment Plant, treated to Title 22 standards for “Disinfected Tertiary Recycled Water”	
<b>Benefits</b>		
Diversifying Water Sources	236 AFY of drought-proof locally controlled water supply for non-potable uses	
Sustainability	Conserves potable water for its highest beneficial use	
<b>Costs</b>		
Capital Cost	\$17.1 million (April 2015 dollars)	None
Unit Cost (\$/AF)	\$4,300/AF (delivered)	\$2,713/AF in 2014/15 (wholesale – see Chapter 2)
Other Potential Future Costs/Risks	Other users reduced need for irrigation water if turf replaced with zero-water landscaping elements	<ul style="list-style-type: none"> <li>• Risk of unavailable supplies during periods of drought</li> <li>• Risk of supply interruption following a catastrophic event (e.g. earthquake)</li> <li>• Risk of additional future cost increases</li> </ul>

## Chapter 9 Implementation Plan

The following sections evaluate various institutional, financing and environmental areas of the recommended project.

### 9.1 Institutional Needs

#### Water Use Commitments

WBSD has developed an MOU with Sharon Heights G&CC, to partner in developing and funding the project, and also to be the primary user of the recycled water produced. A market assurance from SLAC could take the form of a letter of intent or user agreement and can be modeled after relevant portions of the SH G&CC MOU. The MOU is included in Appendix F.

#### Water Rights

No water rights issues were identified. WBSD does not currently have an NPDES permit as its wastewater is diverted to SVCW for treatment and discharge to the Bay at the Redwood City facility. Because SVCW is a bay discharger, they do not need a Petition for Change to be filed with the SWRCB due to the change in wastewater discharge volume associated with effluent diverted to the project.

#### Permitting and Agreements

Several permits were identified as necessary for the implementation of the recommended project. Foremost, WBSD would need to obtain a water recycled permit to serve recycled water. WBSD currently operates its sewers under the collection system general order, and would need to enroll in the newly adopted General Water Discharge Requirements for Recycled Water Use (General Order, WQ 2014-0900-DWQ). Standard construction permits including encroachment and air quality permits would also be required.

One interagency agreement was identified. A recycled water agreement with the City to serve recycled water to MPMWD customers is required to avoid duplication of service issues within the City's jurisdiction. WBSD has been working with the City and MPMWD on developing an MOU, and the City is supportive of recycled water. No recycled water service will be provided to Cal Water customers as part of the recommended project, so a recycled water agreement with Cal Water is not needed at this time.

Lastly, WBSD will curtail the sewer flow diverted to SVCW by 0.5 mgd however no formal agreement is required to reduce the flow to SVCW. The flow reduction will result in a slightly reduced flow charge to WBSD.

#### Right of Way Acquisition

No right of way acquisition was identified, however WBSD will need to coordinate ROW crossing with SFPUC for the crossing of the Hetch-Hetchy aqueduct in Sand Hill Road, and also coordinate to use the City's ROW to construct the pipeline along Sand Hill Road.

#### Unresolved Issues

WBSD is still in discussions regarding recycled water purveyor and conveyance rights with the City and MPMWD. Resolution is expected in the late July 2015 timeframe.

### 9.2 Financing Plan

This section discusses potential funding sources for the project, the construction financing plan and associated cash flow over the implementation period. Typically, recycled water projects are financed through a combination of grants, partnerships relative to project benefits, and the State Water Resource Control Board (SWRCB) State Revolving Fund (SRF).

### 9.2.1 Funding Opportunities

A variety of funding opportunities are possible for this project, including the following:

- Integrated Regional Water Management (IRWM) Program Funding
- US Bureau of Reclamation (USBR) Title XVI Funding
- SWRCB Recycled Water Funding
- California Infrastructure and Economic Development Bank (I-Bank) Infrastructure SRF Program

Each of these funding opportunities is described in further detail in the following sections.

#### **Integrated Regional Water Management (IRWM) Program Funding**

The Integrated Regional Water Management (IRWM) Program, administered by the California Department of Water Resources (DWR), provides planning and implementation grants to prepare and update IRWM Plans and to implement integrated, regional water resources related projects.

Funding is currently available through Proposition 84 (Prop 84), the Safe Drinking Water, Water Quality and Supply, Flood Control, River and Coastal Protection Act of 2006. Additional funding will become available from Proposition 1 in mid to late 2016 with draft guidelines expected in January of 2016.

IRWM program funding is awarded through a competitive grants program, in which approved IRWM Regions submit application packages for funding multiple projects within their regions. In order for a project to be eligible for IRWM funding, it must be included in an IRWM Region's IRWM Plan and preferably be ready to be implemented. This project falls within the San Francisco Bay Area IRWM Region, and therefore must be included within the San Francisco Bay Area IRWM Plan (BAIRWMP) to be eligible for IRWM funding. IRWM funding requires a 25% match for the entire grant proposal, which typically includes multiple projects from different sponsors. It is expected that this same model will be used when Prop 1 funding takes effect.

To prepare for the upcoming application process, the San Francisco Bay Area IRWM Region will issue a call for projects by the subregions. Prior to submitting the projects for consideration by the subregions, they must be submitted for inclusion in the Bay Area IRWM Plan. This can be done at any time through submittal to an online database.

Figure 9-1 illustrates the steps of the IRWM funding process from project submittal into the BAIRWMP to the subregional ranking to the final project proposal package. It is anticipated that Proposition 1 IRWM funding will carry similar requirements to Proposition 84 IRWM funding, and will be distributed through competitive grants in a similar manner following exhaustion of Proposition 84 funding. Additional information about the IRWM grant program can be accessed here: <http://www.water.ca.gov/irwm/grants/index.cfm>

Figure 9-1: Prop 84 Grant Process



### **US Bureau of Reclamation (USBR) Title XVI – Grant Funding**

Processed through the USBR, the Title XVI grant program is focused on identifying and investigating opportunities for water reclamation and reuse. Funding is made available for the planning, design, and construction of water recycling treatment and conveyance facilities and structured to cover 25% of the total project costs (up to \$20 million), with project proponents contributing 75% or more of total project costs. Proposal requirements include technical and budgetary components, as well as a completed Title XVI Feasibility Study, which must be submitted to USBR for review and approval. While compliance with the National Environmental Policy Act (NEPA) is not required during the proposal phase, it is required prior to the receipt and expenditure of Federal funds. Additionally, in order to be eligible to receive Title XVI funding, a project must be congressionally authorized.

Based on communication with USBR staff, USBR may replace the grant program with a low-interest (1 percent), 30-year loan program. Alternatively, it may create a joint-grant and loan program. The timing or certainty of these changes are currently unknown. More information is available from USBR’s website here: <http://www.usbr.gov/lc/socal/titlexvi.html/>

### **State Water Resources Control Board Recycled Water Funding**

The SWRCB administers three types of recycled water funding: recycled water facilities planning grants, construction implementation grants and loans, and clean water state revolving fund loans. Construction grants and loans specific to recycled water programs fall under the Water Recycling Funding Program (WRFP) and follow the clean water state revolving fund policy. With the Facilities Plan in place, WBSD can focus on obtaining grants or low interest loans to cover the construction implementation costs.

#### ***Facility Construction Grants***

The SWRCB currently administers a grants program to cover construction of recycled water facilities. Funding will come from the Proposition 1 grant passed in November 2014 and makes available \$725 million for recycled water and desalination projects. At the writing of this plan, it is estimated that \$100 million will go towards desalination projects administered through the Department of Water Resources and \$625 million will be available through SWRCB for planning and facilities construction grants and low interest loans.

The State Board’s Water Recycling Funding Program Guidelines adopted on June 16, 2015, provide a construction grant that will cover 35% of actual eligible construction costs up to \$15 million, including construction allowances. Eligible costs include construction allowances which may include engineering during construction, construction management, and contingencies limited to 15% of the construction grant value. To be eligible to receive grant funds, at least a 50% local cost share match must be provided.

#### ***Clean Water State Revolving Fund (CWSRF) Loans***

The SWRCB administers the Clean Water State Revolving Fund (CWSRF) Loan Program. This Program offers low-interest loans to eligible applicants for construction of publicly-owned facilities including wastewater treatment, local sewers, sewer interceptors, water reclamation facilities, and stormwater

treatment. Funding under this Program is also available for expanded use projects including implementation of nonpoint source projects or programs, and development and implementation of estuary comprehensive conservation and management plans.

The process for securing funds includes submitting a CWSRF application, in addition to additional water recycling project-specific application items. CWSRF loans typically have a lower interest rate than bonds, at half of the General Obligation bond (typically 2.5% to 3%, currently 2.1%) at the time of the Preliminary Funding Commitment. Loans are paid back over 20 or 30 years. Annually, the CWSRF program disburses \$200 million to \$300 million to agencies in California. There is no award maximum, but a maximum allocation of \$50 million per year per agency exists. Repayment begins one year after construction is complete. SWRCB funds projects on a readiness-to-proceed basis. The application process can take up to 6 months; SWRCB recommends collecting required information and applying once the draft California Environmental Quality Act (CEQA) and additional federal requirements (i.e. CEQA+) documents, required resolutions, and financial package are completed. Historically, SWRCB has offered up to \$3 million in principal forgiveness (PF) (i.e. grants) to applicants if the project directly benefits a disadvantaged community (DAC). It is anticipated PF/grants will be made available to DACs in the future. Guidelines for the amounts of PF/grants available to DACs are outlined in the annual Intended Use Plan released by SWRCB each year.

In March of 2014, in response to the Drought Emergency issued by Governor Brown, \$800 million in 1 percent loans was offered to water recycling projects. The WRFPL Loans are available at 1-percent interest until December 2, 2015.

Projects may receive a combination of grant and low interest construction financing. The application process for construction grants and loans is the same and involves completion of an application package consisting of four separate applications to document general project information, financial security, technical project information, and environmental documentation and placement on the competitive funding list. The process is summarized in Figure 9-2.

**Figure 9-2: Facilities Construction Grants and Loans Process**

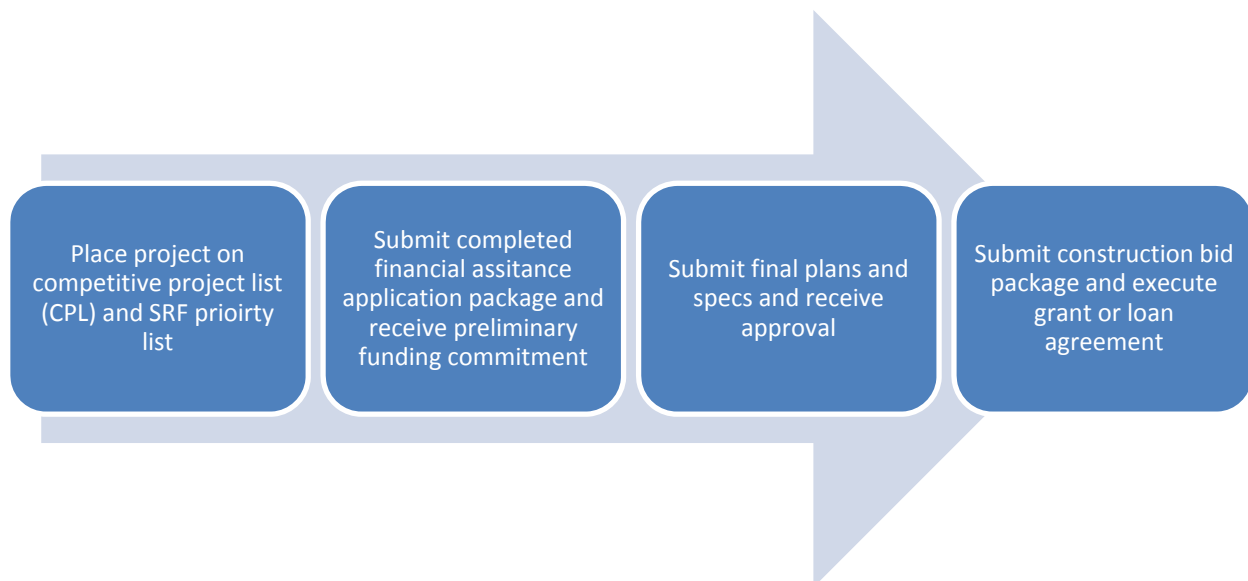

More information about the SWRCB CWSRF Program can be found here: [http://www.waterboards.ca.gov/water\\_issues/programs/grants\\_loans/srf/srf\\_forms.shtml](http://www.waterboards.ca.gov/water_issues/programs/grants_loans/srf/srf_forms.shtml).



**Infrastructure SRF Program – I-Bank**

The Infrastructure SRF (ISRF) Program provides low-interest loan financing to public agencies for a wide variety of infrastructure projects such as water supply, parks and recreation facilities, sewage collection and treatment, and water treatment and distribution projects. Funding is available in amounts up to \$25 million with loan terms up to 30 years. The interest rate is set at the time the loan is approved. Eligible applicants include cities, counties, special districts, assessment districts, joint powers authorities, and nonprofit organizations. Applicants must demonstrate project readiness and feasibility to complete construction within two years after I-Bank loan approval. Additionally, eligible projects must promote economic development and attract, create, and sustain long-term employment opportunities. There is no required match; however, there is a one-time origination fee of 1% of the ISRF financing amount or \$10,000, whichever is greater. Applications are accepted on continuous basis. The I-Bank recommends applications are submitted upon completion of design, as construction must begin within 6 months of the I-Bank’s loan commitment.

More information about the ISRF Program can be found here:  
[http://www.ibank.ca.gov/infrastructure\\_loans.htm](http://www.ibank.ca.gov/infrastructure_loans.htm)

**9.2.2 Funding Opportunity Summary**

There are multiple options to pursue outside funding. Table 9-1 summarizes the funding opportunities deadlines and current grant amounts.

**9.2.3 Construction Financing and Cash Flow**

Figure 9-3 demonstrates cash flow over the implementation period of the recommended project. Costs were summarized as part of Chapter 8, and the unit cost for water at this feasibility level is \$5000/AF. As grants and loans become available to the project, rates and charges will be further refined. Figure 9-3 is an example cash flow chart.

**Figure 9-3: Cash Flow Chart**

West Bay Sanitary District Recycled Water Project											
Design and Construction Cash Flow Analysis <sup>1</sup>											
Year	Quarter	2015				2016				2017	
		Q2	Q3	Q4	Q1	Q2	Q3	Q4	Q1	Q2	Q3
<b>DESIGN/CONSTRUCTION COSTS<sup>2</sup></b>											
Eligible Design/Construction Costs											
CEQA Plus	\$	123,000	\$ 41,000.00	\$ 41,000.00	\$ 41,000.00	\$ -	\$ -	\$ -	\$ -	\$ -	\$ -
State Revolving Fund Activities	\$	100,000	\$ 10,000.00	\$ 30,000.00	\$ 30,000.00	\$ 30,000	\$ -	\$ -	\$ -	\$ -	\$ -
Preliminary Design/DB Procurement Package	\$	437,500	\$ -	\$ -	\$ 54,600	\$ 104,003	\$ 104,003	\$ 54,600	\$ -	\$ -	\$ -
Design Build	\$	16,330,500	\$ -	\$ -	\$ -	\$ -	\$ 1,361,542	\$ 4,004,025	\$ 4,004,025	\$ 4,004,025	\$ 1,361,542
Engineers Report and RW Permit	\$	127,000	\$ -	\$ -	\$ -	\$ -	\$ -	\$ 47,625	\$ 47,625	\$ 31,750	\$ -
<b>TOTAL</b>	<b>\$</b>	<b>17,126,000</b>	<b>\$ 51,000</b>	<b>\$ 71,000</b>	<b>\$ 125,688</b>	<b>\$ 194,063</b>	<b>\$ 1,525,604</b>	<b>\$ 4,139,313</b>	<b>\$ 4,132,250</b>	<b>\$ 4,132,250</b>	<b>\$ 1,393,292</b>
<b>PAYMENTS FROM PROJECT ACCOUNT</b>											
Design/Construction Payment	\$	17,126,000	\$ 51,000	\$ 71,000	\$ 125,688	\$ 194,063	\$ 1,525,604	\$ 4,139,313	\$ 4,132,250	\$ 4,132,250	\$ 1,393,292
<b>TOTAL</b>	<b>\$</b>	<b>17,126,000</b>	<b>\$ 51,000</b>	<b>\$ 71,000</b>	<b>\$ 125,688</b>	<b>\$ 194,063</b>	<b>\$ 1,525,604</b>	<b>\$ 4,139,313</b>	<b>\$ 4,132,250</b>	<b>\$ 4,132,250</b>	<b>\$ 1,393,292</b>

Notes:  
 1. Cash flow analysis does not consider the financing costs, which would be paid back over a period longer than project implementation, so the financing mechanism (e.g. bonds, SRF, etc.) is not considered here.  
 2. Costs based on Facilities Plan cost estimate in April 2015 dollars.

**Table 9-1: Summary of Funding Opportunities**

Opportunity	Application Dates	Grant Amounts
Title XVI – Construction Grants	Unknown	Up to 25% of construction cost with a maximum of \$20M for federal funds
IRWM –Prop 1	Mid-Late 2016	\$2.7 M (SF Bay Region), Prop 1: \$625M available statewide for water recycling projects
SWRCB Facilities Construction Grants	Anticipated late 2015	\$625 M (statewide)
Clean Water SRF Loans	On-going	\$50 M/yr. at 1% - 3% interest rates (statewide)
WRFP SRF Loans	Apply prior to Dec 2, 2015	\$282 M at 1% interest (statewide)
I-Bank SRF Loans	On-going	\$25 M at variable interest rates (statewide)

### 9.3 Preliminary Environmental Review

An Initial Study/Mitigated Negative Declaration (IS/MND) is being prepared to meet California Environmental Quality Act (CEQA) requirements. The IS/MND is expected to be completed by the end of 2015, and as early as October. Included herein, as Appendix E is a preliminary evaluation of expected environmental impacts from implementation (construction and operation) of the Recommended Project. These topics described will be further explored in the IS/MND being prepared.

### 9.4 Design

#### Design-Build

Design-build was selected as the delivery method for the Recommended Project to meet the one-year design and construction schedule discussed in Section 9.5. Following completion and approval of this Plan, WBSD could commence on the pre-design of the satellite treatment plant facilities to finalize the treatment processes, sizing and layout to be used in the final design. Additionally, WBSD will commence on the pre-design of the distribution system to finalize the pipeline alignments, materials, sizing, and customer connections. The pre-design information would be needed to complete the IS/MND.

Upon completion of pre-design and financing package, WBSD could issue a request for proposal to initiate a competitive design-build process. Design-build could allow WBSD and Sharon Heights G&CC to meet the desired one year design and construction schedule

#### Design-Bid-Build

Design-bid-build was considered as a delivery method for the Recommended Project but was not selected because it cannot meet the one-year design and construction schedule.

### 9.5 Implementation Schedule

Planning on the recycled water project began in June 2014, and is proceeding with the development of this Facilities Plan. Moving forward, CEQA is underway and will be followed by design then construction. An implementation schedules for the design-build approach is included as Figure 9-4.

Figure 9-4: Design-Build Implementation Schedule

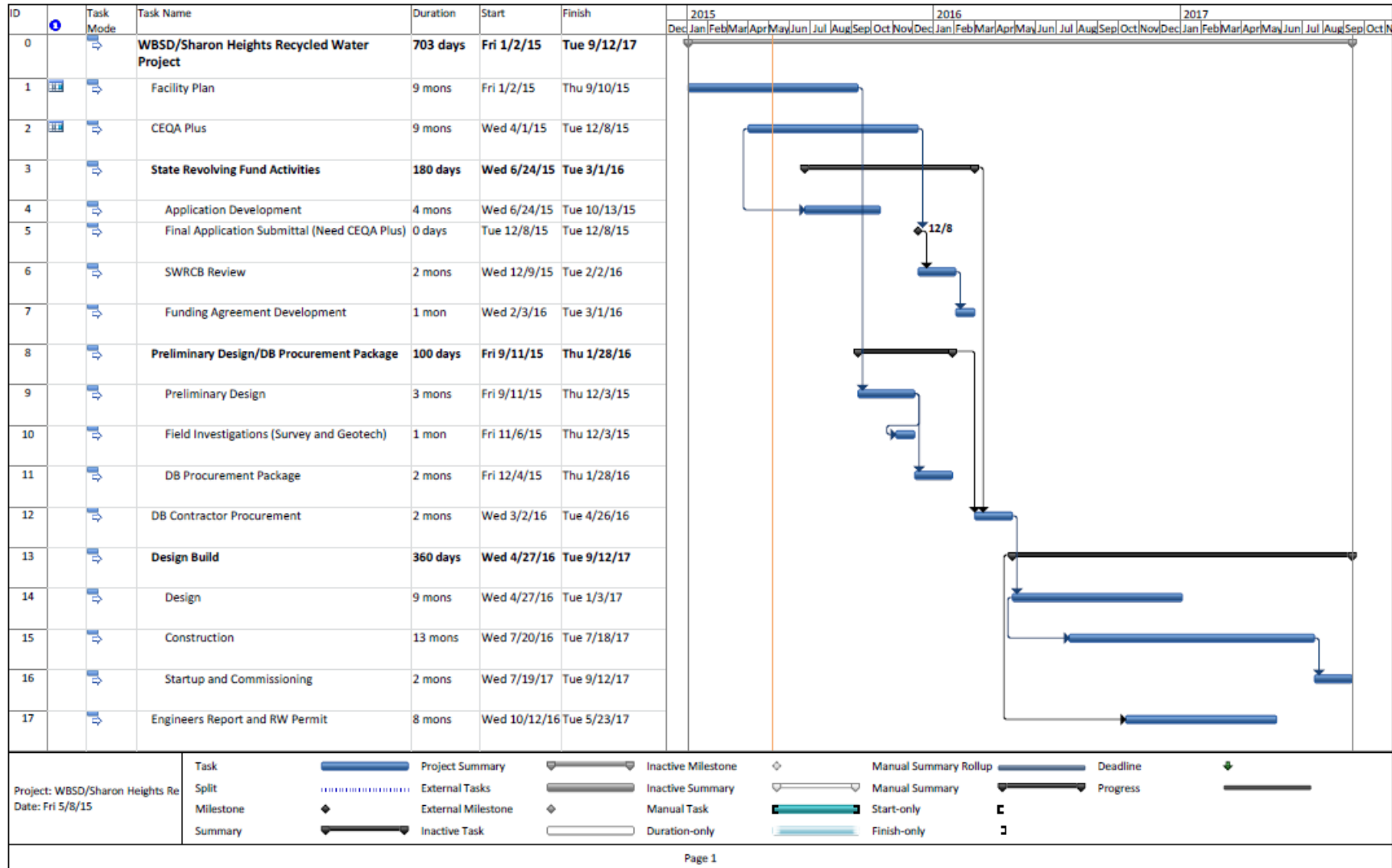

## Chapter 10 Conclusion

Planning on the recycled water project began in June 2014 with the initiation of the Market Survey and is now nearing the design stage with the completion of the Facilities Plan and progress on CEQA. A recommended project has been identified to serve both the Sharon Heights G&CC and SLAC. A strong partnership has been developed by WBSD and Sharon Heights G&CC where the treatment facility will be located. Additionally, SLAC is an enthusiastic recycled water customer and has been very engaged in the last couple months on the project. The City has also expressed support for the recycled water project, and WBSD is in discussions with the City and MPMWD on recycled water purveyorship and conveyance rights. The primary benefit of the recommended project is that SLAC demands are largely outside of the peak irrigation season, allowing recycled water to be produced and served year round. By serving both users the overall cost of the project per unit of water will be less; and more potable water within the SFPUC Hetch Hetchy system will be offset.

## References

Bartle Wells, 2010. City of Menlo Park Water Rate Study, Final Report, April 2010. Bartle Wells Associates, 2010.

RWQCB, 2003. Comprehensive Groundwater Protection Evaluation for the South San Francisco Bay Basins; Groundwater Committee of the California RWQCB San Francisco Bay Region, in cooperation with Alameda County Water District, Santa Clara Valley Water District, and San Mateo County Environmental Health Services Division.

RWQCB, 2014. Alternative Treatment Technology Report for Recycled Water, State Water Resources Control Board Division of Drinking Water, September 2014.

SWRCB, 2015. Regulations Related to Recycled Water, Division of Drinking Water. [http://www.waterboards.ca.gov/drinking\\_water/certlic/drinkingwater/documents/lawbook/RWregulations\\_20150625.pdf](http://www.waterboards.ca.gov/drinking_water/certlic/drinkingwater/documents/lawbook/RWregulations_20150625.pdf). June 25, 2015

Todd, 2005. Final Feasibility of Supplemental Groundwater Resources Development, Menlo Park and East Palo Alto, California. Todd Engineers, August 2005.

USGS, 1997. Ground-Water Development and the Effects on Ground-Water Levels and Water Quality in the Town of Atherton, San Mateo County, California. United States Geological Survey, by Loren Metzger and John Fio. Water Resources Investigations Report 97-4033. 1997.

USGS, 2002. Streamflow Gains and Losses along San Francisquito Creek and Characterization of Surface-Water and Ground-Water Quality, Southern San Mateo and Northern Santa Clara Counties, California. United States Geological Survey, Loren Metzger and John Fio. Water-Resources Investigations Report 02-4078. 2002.

USGS, 1995. Geologic Framework, Historical Development of the Groundwater System, and General Hydrologic and Water Quality Conditions in 1990, South San Francisco Bay and Peninsula Area, California. United States Geological Survey, John Fio and David Leighton. Open File Report 94-357. 1995.

Winzler & Kelly, 2010 (Amended 2014). Final 2010 Urban Water Management Plan and Update to the Water Shortage Contingency Plan, June 2011, Amended November 2014. Winzler & Kelly, 2011.

## **Appendix A - Sand Hill Road Water Quality Data**



## **Appendix B - Alpine Road Water Quality Data**

---





## **Appendix C - Oak Avenue Flow Data**

---

Time	06/12/15	06/13/15	06/14/15	06/15/15	06/16/15	06/17/15	06/18/15	06/19/15	06/20/15	06/21/15
0:00		0.462	0.368	0.412	0.422	0.427	0.443	0.435	0.487	0.365
1:00		0.390	0.350	0.408	0.378	0.427	0.428	0.444	0.444	0.365
2:00		0.384	0.317	0.403	0.328	0.384	0.354	0.387	0.406	0.302
3:00		0.287	0.307	0.350	0.297	0.360	0.246	0.290	0.208	0.238
4:00		0.174	0.183	0.182	0.227	0.287	0.219	0.214	0.124	0.178
5:00		0.137	0.135	0.112	0.138	0.174	0.117	0.166	0.087	0.124
6:00		0.107	0.120	0.067	0.114	0.104	0.117	0.129	0.096	0.091
7:00		0.107	0.120	0.092	0.114	0.104	0.117	0.129	0.087	0.091
8:00		0.107	0.120	0.123	0.114	0.104	0.127	0.166	0.087	0.091
9:00		0.199	0.139	0.258	0.188	0.160	0.153	0.226	0.146	0.129
10:00		0.222	0.215	0.308	0.228	0.277	0.258	0.275	0.193	0.143
11:00	0.337	0.265	0.314	0.559	0.438	0.492	0.492	0.532	0.313	0.236
12:00	0.414	0.419	0.429	0.639	0.505	0.505	0.492	0.540	0.355	0.405
13:00	0.363	0.419	0.477	0.657	0.461	0.505	0.492	0.597	0.361	0.466
14:00	0.373	0.360	0.451	0.593	0.456	0.482	0.586	0.532	0.361	0.471
15:00	0.342	0.530	0.451	0.598	0.457	0.388	0.453	0.482	0.364	0.471
16:00	0.442	0.498	0.425	0.524	0.580	0.382	0.453	0.518	0.324	0.511
17:00	0.538	0.459	0.414	0.494	0.525	0.379	0.444	0.486	0.345	0.507
18:00	0.559	0.451	0.438	0.395	0.497	0.389	0.404	0.235	0.354	0.445
19:00	0.496	0.448	0.421	0.323	0.496	0.399	0.343	0.314	0.374	0.404
20:00	0.496	0.436	0.438	0.319	0.463	0.408	0.317	0.458	0.376	0.389
21:00	0.491	0.441	0.236	0.323	0.472	0.451	0.312	0.343	0.384	0.389
22:00	0.491	0.425	0.463	0.399	0.394	0.408	0.314	0.345	0.377	0.407
23:00	0.462	0.383	0.434	0.445	0.472	0.457	0.321	0.489	0.367	0.424

Note:

1. Flow monitored hourly between 6/12/15 and 6/29/15
2. Flow monitored at 15-minute intervals Between 6/29/15 and 7/9/15. Data in table averaged to hourly values.

Time	06/22/15	06/23/15	06/24/15	06/25/15	06/26/15	06/27/15	06/28/15	06/29/15	06/30/15	07/01/15
0:00	0.430	0.453	0.431	0.442	0.434	0.444	0.409	0.532	0.537	0.450
1:00	0.427	0.414	0.419	0.436	0.434	0.423	0.429	0.467	0.489	0.361
2:00	0.407	0.317	0.388	0.434	0.346	0.423	0.429	0.422	0.336	0.221
3:00	0.252	0.341	0.238	0.321	0.321	0.306	0.372	0.260	0.281	0.179
4:00	0.192	0.239	0.166	0.273	0.279	0.230	0.202	0.224	0.227	0.150
5:00	0.185	0.235	0.149	0.132	0.198	0.151	0.189	0.149	0.166	0.123
6:00	0.133	0.117	0.097	0.115	0.139	0.093	0.123	0.149	0.223	0.118
7:00	0.133	0.115	0.097	0.115	0.139	0.093	0.123	0.149	0.287	0.215
8:00	0.133	0.115	0.097	0.132	0.139	0.093	0.123	0.168	0.471	0.411
9:00	0.219	0.136	0.162	0.134	0.219	0.139	0.161	0.266	0.533	0.497
10:00	0.398	0.414	0.423	0.211	0.525	0.183	0.255	0.326	0.533	0.497
11:00	0.574	0.640	0.517	0.490	0.591	0.273	0.260	0.452	0.662	0.576
12:00	0.620	0.640	0.542	0.511	0.662	0.456	0.469	0.631	0.662	0.678
13:00	0.503	0.640	0.387	0.511	0.711	0.593	0.478	0.631	0.619	0.613
14:00	0.545	0.576	0.369	0.604	0.505	0.646	0.633	0.488	0.570	0.528
15:00	0.540	0.461	0.308	0.482	0.471	0.499	0.588	0.581	0.595	0.625
16:00	0.531	0.430	0.307	0.395	0.583	0.524	0.530	0.558	0.620	0.582
17:00	0.516	0.405	0.447	0.468	0.583	0.550	0.528	0.515	0.227	0.422
18:00	0.461	0.411	0.479	0.468	0.481	0.577	0.526	0.469	0.446	0.459
19:00	0.446	0.388	0.451	0.440	0.479	0.550	0.474	0.493	0.472	0.500
20:00	0.446	0.378	0.451	0.440	0.418	0.550	0.474	0.500	0.507	0.472
21:00	0.516	0.378	0.440	0.434	0.409	0.435	0.468	0.519	0.481	0.567
22:00	0.296	0.419	0.436	0.434	0.421	0.435	0.508	0.519	0.406	0.489
23:00	0.296	0.431	0.432	0.434	0.435	0.393	0.600	0.552	0.456	0.405

Note:

1. Flow monitored hourly between 6/12/15 and 6/29/15
2. Flow monitored at 15-minute intervals Between 6/29/15 and 7/9/15. Data in table averaged to hourly values.

Time	07/02/15	07/03/15	07/04/15	07/05/15	07/06/15	07/07/15	07/08/15	07/09/15
0:00	0.394	0.423	0.361	0.317	0.411	0.475	0.404	0.427
1:00	0.340	0.366	0.300	0.309	0.341	0.340	0.338	0.385
2:00	0.324	0.277	0.200	0.248	0.265	0.258	0.223	0.260
3:00	0.194	0.179	0.193	0.167	0.169	0.207	0.168	0.201
4:00	0.100	0.132	0.109	0.153	0.127	0.125	0.104	0.113
5:00	0.115	0.106	0.104	0.111	0.100	0.103	0.098	0.085
6:00	0.115	0.098	0.104	0.111	0.081	0.096	0.129	0.191
7:00	0.333	0.141	0.108	0.126	0.245	0.253	0.303	0.202
8:00	0.434	0.267	0.219	0.175	0.427	0.416	0.442	0.470
9:00	0.520	0.405	0.358	0.339	0.617	0.588	0.585	0.695
10:00	0.557	0.619	0.530	0.386	0.682	0.344	0.770	0.545
11:00	0.594	0.663	0.566	0.582	0.668	0.712	0.720	
12:00	0.582	0.406	0.651	0.603	0.660	0.697	0.704	
13:00	0.594	0.577	0.612	0.576	0.639	0.613	0.337	
14:00	0.548	0.557	0.533	0.518	0.610	0.599	0.638	
15:00	0.572	0.548	0.506	0.465	0.602	0.552	0.634	
16:00	0.496	0.452	0.483	0.532	0.566	0.533	0.465	
17:00	0.481	0.579	0.504	0.482	0.508	0.499	0.499	
18:00	0.503	0.579	0.476	0.437	0.458	0.513	0.494	
19:00	0.510	0.519	0.452	0.443	0.447	0.496	0.492	
20:00	0.452	0.519	0.483	0.442	0.465	0.535	0.510	
21:00	0.471	0.451	0.385	0.435	0.480	0.535	0.578	
22:00	0.501	0.425	0.385	0.459	0.440	0.574	0.575	
23:00	0.472	0.454	0.395	0.461	0.497	0.465	0.510	

Note:

1. Flow monitored hourly between 6/12/15 and 6/29/15
2. Flow monitored at 15-minute intervals Between 6/29/15 and 7/9/15. Data in table averaged to hourly values.

## **Appendix D - Project Alternative Cost Estimates**



Project:

West Bay Sanitary District RW Facilities Plan

Aspect:

Cost Estimate - Satellite Treatment Plant Options

Estimate Type:

Divisions	1A - Sharon Heights Golf Course ONLY -MBR	2A - Sharon Heights Golf Course + SLAC - MBR	3A - Sharon Heights Golf Course + Other Users - MBR	1B - Sharon Heights Golf Course ONLY - SBR + Cloth Media Filtration	2B - Sharon Heights Golf Course + SLAC - SBR + Cloth Media Filtration	3B - Sharon Heights Golf Course + Other Users - SBR + Cloth Media Filtration	1C - Sharon Heights Golf Course ONLY - SBR + Sand Filtration	2C - Sharon Heights Golf Course + SLAC - SBR + Sand Filtration	3C - Sharon Heights Golf Course + Other Users - SBR + Sand Filtration
Influent Pump Station	\$614,000	\$614,000	\$614,000	\$614,000	\$614,000	\$614,000	\$614,000	\$614,000	\$614,000
Influent Pipeline	\$1,774,000	\$1,774,000	\$1,774,000	\$1,774,000	\$1,774,000	\$1,774,000	\$1,774,000	\$1,774,000	\$1,774,000
Treatment Facilities	\$6,768,000	\$6,768,000	\$6,768,000	\$5,469,000	\$5,526,000	\$5,526,000	\$5,643,000	\$5,699,000	\$5,699,000
Distribution Pump Station	\$375,000	\$454,000	\$454,000	\$375,000	\$454,000	\$391,000	\$375,000	\$454,000	\$454,000
Distribution Pipeline	\$0	\$665,000	\$798,000	\$0	\$665,000	\$798,000	\$0	\$665,000	\$798,000
<b>Subtotal Raw Construction Cost</b>	<b>\$9,531,000</b>	<b>\$10,275,000</b>	<b>\$10,408,000</b>	<b>\$8,232,000</b>	<b>\$9,033,000</b>	<b>\$9,144,000</b>	<b>\$8,406,000</b>	<b>\$9,207,000</b>	<b>\$9,340,000</b>
Construction Contingency	\$2,859,000	\$3,083,000	\$3,122,000	\$2,470,000	\$2,710,000	\$2,743,000	\$2,522,000	\$2,762,000	\$2,802,000
<b>Base Construction Cost</b>	<b>\$12,390,000</b>	<b>\$13,358,000</b>	<b>\$13,530,000</b>	<b>\$10,702,000</b>	<b>\$11,743,000</b>	<b>\$11,887,000</b>	<b>\$10,928,000</b>	<b>\$11,969,000</b>	<b>\$12,142,000</b>
Implementation Costs	\$2,600,000	\$3,100,000	\$3,000,000	\$2,600,000	\$3,100,000	\$3,000,000	\$2,600,000	\$3,100,000	\$3,000,000
Project Contingency	\$620,000	\$668,000	\$677,000	\$535,000	\$587,000	\$595,000	\$547,000	\$599,000	\$607,000
<b>Total Estimated Capital Cost</b>	<b>\$15,610,000</b>	<b>\$17,126,000</b>	<b>\$17,207,000</b>	<b>\$13,837,000</b>	<b>\$15,430,000</b>	<b>\$15,482,000</b>	<b>\$14,075,000</b>	<b>\$15,668,000</b>	<b>\$15,749,000</b>
<b>Annual Costs</b>									
Annual Cost of Consumables	\$ 97,000	\$ 105,000	\$ 106,000	\$ 76,000	\$ 38,000	\$ 83,000	\$ 80,000	\$ 85,000	\$ 86,000
Annual Cost of Power	\$ 82,000	\$ 99,000	\$ 88,000	\$ 62,000	\$ 78,000	\$ 68,000	\$ 66,000	\$ 82,000	\$ 72,000
Annual Cost of Chemicals	\$ 2,000	\$ 2,000	\$ 2,000	\$ 300	\$ 300	\$ 300	\$ 300	\$ 300	\$ 300
Annual Labor Costs	\$ 52,000	\$ 52,000	\$ 52,000	\$ 52,000	\$ 52,000	\$ 52,000	\$ 52,000	\$ 52,000	\$ 52,000
<b>Total Annual O&amp;M</b>	<b>\$ 233,000</b>	<b>\$ 258,000</b>	<b>\$ 248,000</b>	<b>\$ 190,000</b>	<b>\$ 168,000</b>	<b>\$ 203,000</b>	<b>\$ 198,000</b>	<b>\$ 219,000</b>	<b>\$ 210,000</b>
<b>Annualized Capital Costs</b>									
Annualized Capital Costs	\$ 697,000	\$ 765,000	\$ 768,000	\$ 618,000	\$ 689,000	\$ 691,000	\$ 628,000	\$ 700,000	\$ 703,000
<b>Total Annualized Cost</b>	<b>\$ 930,000</b>	<b>\$ 1,023,000</b>	<b>\$ 1,016,000</b>	<b>\$ 808,000</b>	<b>\$ 857,000</b>	<b>\$ 894,000</b>	<b>\$ 826,000</b>	<b>\$ 919,000</b>	<b>\$ 913,000</b>
<b>Project Unit Costs</b>									
Project Recycled Water Yield (AFY)	152	236	197	152	236	197	152	236	197
Project Unit Cost (\$/AFY)	\$ 6,100	\$ 4,300	\$ 5,200	\$ 5,300	\$ 3,600	\$ 4,500	\$ 5,400	\$ 3,900	\$ 4,600
Project Unit Cost without Capital Cost (\$/AFY)	\$ 1,500	\$ 1,100	\$ 1,300	\$ 1,300	\$ 700	\$ 1,000	\$ 1,300	\$ 900	\$ 1,100

Notes:

1. Annualized cost are based on a State Revolving Fund Financing of 30 years at 2.0% interest rate.

**Project:** West Bay Sanitary District RW Facilities Plan  
**Alternative:** 1A - Sharon Heights Golf Course ONLY  
**Treatment:** MBR

Date: June 12, 2015  
Project Number: 606-001

Prepared by: SAM  
Checked by:

Avg Annual Demand (AFY)

152

Estimate Type: Conceptual Design

**Process Cost Summary by Division**

Spec. Division	Subtotal	Notes
2 - Sitework	\$ 2,606,211	
3 - Concrete	\$ 2,469,750	
5 - Metals	\$ 30,000	
9 - Finishes	\$ 20,000	
11 - Equipment	\$ 2,910,000	
15 - Mechanical	\$ 40,000	
16 - Electrical	\$ 873,000	
17- I&C	\$ 582,000	
	<b>RAW CONSTRUCTION COST \$ 9,531,000</b>	
	Construction Contingency 30% \$ 2,859,000	
	<b>BASE CONSTRUCTION COST \$ 12,390,000</b>	
	Environmental \$ 123,000	
	Permitting \$ 127,000	
	Design for PS, WW FM, Plant \$ 1,500,000	
	Design for Distribution Pipeline \$ -	
	CM for PS and coveyance FM \$ 250,000	
	CM for Treatment Plant \$ 500,000	
	CM for Distribution Pipeline \$ -	
	Financing \$ 100,000	
	<b>IMPLEMENTATION COST \$ 2,600,000</b>	
	5% \$ 620,000	
	<b>PROJECT CONTINGENCY \$ 620,000</b>	
	<b>TOTAL PROJECT COST \$ 15,610,000</b>	

Spec. Division	Item	Size	Units	Quantity	Unit	Unit Cost	Total Cost	Notes
<b>2 - Sitework</b>							<b>\$ 2,606,211</b>	
	Influent Pump Station Mobilization/Demobilization			585,000		5%	\$ 29,250	
	Influent Pipeline Mobilization/Demobilization			1,689,600		5%	\$ 84,480	
	Treatment Facilities Mobilization/Demobilization			6,445,505		5%	\$ 322,275	
	Distribution Pump Station Mobilization/Demobilization			357,000		5%	\$ 17,850	
	<b>Influent Pump Station</b>						\$ -	
	<b>Influent Pipeline</b>						\$ 1,689,600	
	8" Pipe, Forcemain from collection system	8	in	10,560	LF	\$ 160	\$ 1,689,600	Conveys raw wastewater to site
	<b>Treatment Facilities</b>						\$ 462,755	
	Site Cleaning			1	Days	\$ 5,000	\$ 5,000	
	Excavation for Treatment Structure			9,000	CY	\$ 10	\$ 90,000	108 ft x 57 ft x 20 ft, 1:1 excavation
	Excavation for Effluent Pump Station			2,200	CY	\$ 10	\$ 22,000	57 ft x 28 ft x 13 ft, 1:1 excavation
	Backfill			5,300	CY	\$ 7	\$ 39,436	
	Offhaul			11,200	CY	\$ 11	\$ 118,759	Assumes all excavation is offhauled
	Dewatering			1	LS	\$ 20,000	\$ 20,000	
	Landscaping Allowance			1	LS	\$ 10,000	\$ 10,000	
	Misc site work			1	LS	\$ 15,000	\$ 15,000	
	6" Pipe, Solids discharge to existing sewer	6	in	1,584	LF	\$ 90	\$ 142,560	Connects to existing sewer
<b>3 - Concrete</b>							<b>\$ 2,469,750</b>	
	<b>Influent Pump Station</b>						\$ -	
	<b>Influent Pipeline</b>						\$ -	
	<b>Treatment Facilities</b>						\$ 2,172,750	
	Treatment Structure Slab			700	CY	\$ 600	\$ 420,000	109 ft x 58 ft, 3 ft thick
	Treatment Structure Elevated slab			370	CY	\$ 850	\$ 314,500	5000 sf, 2 ft thick
	Treatment Structure Walls			540	CY	\$ 1,200	\$ 648,000	18 ft high, 1.5 ft thick
	Treatment Building			6322	SF	\$ 125	\$ 790,250	109 ft x 58 ft, Pre-fabricated structure
	<b>Distribution Pump Station</b>						\$ 297,000	
	Slab			190	CY	\$ 600	\$ 114,000	58 ft x 29 ft, 3 ft thick
	Elevated slab			60	CY	\$ 850	\$ 51,000	57 ft x 28 ft, 1 ft thick
	Walls			110	CY	\$ 1,200	\$ 132,000	12 ft high, 1.5 ft thick
	<b>Distribution Pipeline</b>						\$ -	
<b>5 - Metals</b>							<b>\$ 30,000</b>	
	<b>Influent Pump Station</b>						\$ -	
	<b>Influent Pipeline</b>						\$ -	
	<b>Treatment Facilities</b>						\$ 30,000	
	Misc Metals			1	LS	\$ 30,000	\$ 30,000	
	<b>Distribution Pump Station</b>						\$ -	
	<b>Distribution Pipeline</b>						\$ -	
<b>9 - Finishes</b>							<b>\$ 20,000</b>	
	<b>Influent Pump Station</b>						\$ -	
	<b>Influent Pipeline</b>						\$ -	
	<b>Treatment Facilities</b>						\$ 20,000	
	Finishes Allowance			1	LS	\$ 20,000	\$ 20,000	
	<b>Distribution Pump Station</b>						\$ -	
	<b>Distribution Pipeline</b>						\$ -	
<b>11 - Equipment</b>							<b>\$ 2,910,000</b>	
	<b>Influent Pump Station</b>						\$ 390,000	
	Submersible Pumps	30	hp	2	EA	\$ 6,500	\$ 390,000	Estimate for complete pump station
	<b>Influent Pipeline</b>						\$ -	
	<b>Treatment Facilities</b>						\$ 2,480,000	
	Grit Removal			1	LS	\$ 150,000	\$ 150,000	Includes allowance for installation
	Screens and Washer Compactor			1	LS	\$ 340,000	\$ 340,000	Includes allowance for installation
	MBR Package			1	LS	\$ 1,280,000	\$ 1,280,000	Vendor quote
	MBR Equipment Installation			1	LS	\$ 320,000	\$ 320,000	25% of equipment cost
	UV Disinfection			1	LS	\$ 300,000	\$ 300,000	Includes allowance for installation
	Odor Control			1	LS	\$ 90,000	\$ 90,000	Includes allowance for installation
	<b>Distribution Pump Station</b>						\$ 40,000	
	Vertical Turbine Pumps (RW to Storage Ponds)			2	EA	\$ 20,000	\$ 40,000	
	<b>Distribution Pipeline</b>						\$ -	
<b>15 - Mechanical</b>							<b>\$ 40,000</b>	
	<b>Influent Pump Station</b>						\$ -	
	<b>Influent Pipeline</b>						\$ -	
	<b>Treatment Facilities</b>						\$ 40,000	
	Misc. Mechanical			1	LS	\$ 40,000	\$ 40,000	
	<b>Distribution Pump Station</b>						\$ -	
	<b>Distribution Pipeline</b>						\$ -	
<b>16 - Electrical</b>							<b>\$ 873,000</b>	
	<b>Influent Pump Station</b>						\$ 117,000	
	Electrical Allowance					30%	\$ 117,000	30% of Division 11 (Equipment)
	<b>Influent Pipeline</b>						\$ -	
	<b>Treatment Facilities</b>						\$ 744,000	



Electrical Allowance				30%	\$	744,000	30% of Division 11 (Equipment)
<b>Distribution Pump Station</b>					\$	<b>12,000</b>	
Electrical Allowance				30%	\$	12,000	30% of Division 11 (Equipment)
<b>Distribution Pipeline</b>							
<b>17 - I&amp;C</b>					\$	<b>582,000</b>	
<b>Influent Pump Station</b>					\$	<b>78,000</b>	
I&C Allowance				20%	\$	78,000	20% of Division 11 (Equipment)
<b>Influent Pipeline</b>					\$		
<b>Treatment Facilities</b>					\$	<b>496,000</b>	
I&C Allowance				20%	\$	496,000	20% of Division 11 (Equipment)
<b>Distribution Pump Station</b>					\$	<b>8,000</b>	
I&C Allowance				20%	\$	8,000	20% of Division 11 (Equipment)
<b>Distribution Pipeline</b>							
<b>ANNUAL O&amp;M COSTS</b>							
		<b>Amount</b>	<b>Unit</b>		<b>Value</b>	<b>Cost</b>	
<b>Consumables</b>					Total Consumables	\$	<b>97,000</b>
Equipment Consumables		\$ 2,910,000			2%	\$	58,200 2% of Equipment
Electrical Consumables		\$ 873,000			2%	\$	17,460 2% of Electrical
Instrumentation Consumables		\$ 582,000			2%	\$	11,640 2% of Instrumentation
Pipeline Consumables		\$ 1,874,928			0.5%	\$	9,375 0.5% of Pipeline
<b>Power Costs</b>					Total Power	\$	<b>82,000</b>
WW Pump Station		75,848	kwh	\$	0.15	\$	11,377
<b>Headworks Screen</b>							
Grit Screw		2722	kwh	\$	0.15	\$	408
Grit Conveyor		227	kwh	\$	0.15	\$	34
Headworks Screen		490	kwh	\$	0.15	\$	73
<b>MBR</b>							
Permeate Pumps		13335	kwh	\$	0.15	\$	2,000
Recirculation Pumps		73189	kwh	\$	0.15	\$	10,978
Denitrification Pumps		16079	kwh	\$	0.15	\$	2,412
Membrane Blowers		27218	kwh	\$	0.15	\$	4,083
Process Blowers		81654	kwh	\$	0.15	\$	12,248
Anoxic Mixers		68045	kwh	\$	0.15	\$	10,207
LUV		27218	kwh	\$	0.15	\$	4,083
<b>Effluent Pumping</b>							
To Storage Pond		7290	kwh	\$	0.15	\$	1,094
<b>Chemicals</b>							
Hypochlorite Dosing		5444	kwh	\$	0.15	\$	817
Citric Acid Dosing		227	kwh	\$	0.15	\$	34
<b>Odor Control</b>							
Odor Control Fans		108872	kwh	\$	0.15	\$	16,331
Site Electrical		36500	kwh	\$	0.15	\$	5,475
<b>Chemicals</b>					Total Chemicals	\$	<b>2,000</b>
Hypochlorite		255	gal	\$	1	\$	255
Citric Acid		165	gal	\$	4	\$	660
Caustic		3	dry ton	\$	450	\$	1,350
<b>Labor Costs</b>					Total Labor	\$	<b>52,000</b>
	Total # Operators	1	number				
	Average Annual Hours per operator	520	hrs/yr				Assume 16 hrs/wk, 6 mo of the year & 4 hrs/wk, 6 mo of the year
	Total Operators per year	520	Total hrs	\$	100	\$	<b>52,000</b>
<b>TOTAL ANNUAL O&amp;M COSTS</b>						\$	<b>233,000</b>

Project: West Bay Sanitary District RW Facilities Plan  
 Alternative: 2A - Sharon Heights Golf Course + SLAC  
 Treatment: MBR

Date: June 12, 2015  
 Project Number: 606-001

Prepared by: SAM  
 Checked by:

Avg Annual Demand (AFY)

236

Estimate Type: Conceptual Design

Process Cost Summary by Division

Spec. Division	Subtotal	Notes
2 - Sitework	\$ 3,275,241	
3 - Concrete	\$ 2,469,750	
5 - Metals	\$ 30,000	
9 - Finishes	\$ 20,000	
11 - Equipment	\$ 2,960,000	
15 - Mechanical	\$ 40,000	
16 - Electrical	\$ 888,000	
17 - I&C	\$ 592,000	
	<b>RAW CONSTRUCTION COST \$ 10,275,000</b>	
	Construction Contingency 30% \$ 3,083,000	
	<b>BASE CONSTRUCTION COST \$ 13,360,000</b>	
	Environmental \$ 123,000	
	Permitting \$ 127,000	
	Design for PS, WW FM, Plant \$ 1,500,000	
	Design for Distribution Pipeline \$ 250,000	
	CM for PS and conveyance FM \$ 250,000	
	CM for Treatment Plant \$ 500,000	
	CM for Distribution Pipeline \$ 250,000	
	Financing \$ 100,000	
	<b>IMPLEMENTATION COST \$ 3,100,000</b>	
	5% \$ 668,000	
	<b>PROJECT CONTINGENCY \$ 668,000</b>	
	<b>TOTAL PROJECT COST \$ 17,126,000</b>	

Spec. Division	Item	Size	Units	Quantity	Unit	Unit Cost	Total Cost	Notes
2 - Sitework							\$ 3,275,241	
	Influent Pump Station Mobilization/Demobilization			585,000		5%	\$ 29,250	
	Influent Pipeline Mobilization/Demobilization			1,689,600		5%	\$ 84,480	
	Treatment Facilities Mobilization/Demobilization			6,445,505		5%	\$ 322,275	
	Distribution Pump Station Mobilization/Demobilization			432,000		5%	\$ 21,600	
	Distribution Pipeline Mobilization/Demobilization			633,600		5%	\$ 31,680	
	<b>Influent Pump Station</b>						\$ -	
	<b>Influent Pipeline</b>						\$ 1,689,600	
	8" Pipe, Forcemain from collection system	8	in	10,560	LF	\$ 160	\$ 1,689,600	Conveys raw wastewater to site
	<b>Treatment Facilities</b>						\$ 462,755	
	Site Clearing			1	Days	\$ 5,000	\$ 5,000	
	Excavation for Treatment Structure			9,000	CY	\$ 10	\$ 90,000	108 ft x 57 ft x 20 ft, 1:1 excavation
	Excavation for Effluent Pump Station			2,200	CY	\$ 10	\$ 22,000	57 ft x 28 ft x 13 ft, 1:1 excavation
	Backfill			5,300	CY	\$ 7	\$ 39,436	
	Offhaul			11,200	CY	\$ 11	\$ 118,759	Assumes all excavation is offhauled
	Dewatering			1	LS	\$ 20,000	\$ 20,000	
	Landscaping Allowance			1	LS	\$ 10,000	\$ 10,000	
	Misc site work			1	LS	\$ 15,000	\$ 15,000	
	6" Pipe, Solids discharge to existing sewer	6	in	1,584	LF	\$ 90	\$ 142,560	Connects to existing sewer
	<b>Distribution Pump Station</b>						\$ -	
	<b>Distribution Pipeline</b>						\$ 633,600	
	Recycled water to SLAC	6	in	5,280	LF	\$ 120	\$ 633,600	
3 - Concrete							\$ 2,469,750	
	<b>Influent Pump Station</b>						\$ -	
	<b>Influent Pipeline</b>						\$ -	
	<b>Treatment Facilities</b>						\$ 2,172,750	
	Treatment Structure Slab			700	CY	\$ 600	\$ 420,000	109 ft x 58 ft, 3 ft thick
	Treatment Structure Elevated slab			370	CY	\$ 850	\$ 314,500	5000 sf, 2 ft thick
	Treatment Structure Walls			540	CY	\$ 1,200	\$ 648,000	18 ft high, 1.5 ft thick
	Treatment Building			6322	SF	\$ 125	\$ 790,250	109 ft x 58 ft, Pre-fabricated structure
	<b>Distribution Pump Station</b>						\$ 297,000	
	Slab			190	CY	\$ 600	\$ 114,000	58 ft x 29 ft, 3 ft thick
	Elevated slab			60	CY	\$ 850	\$ 51,000	57 ft x 28 ft, 1 ft thick
	Walls			110	CY	\$ 1,200	\$ 132,000	12 ft high, 1.5 ft thick
	<b>Distribution Pipeline</b>						\$ -	
5 - Metals							\$ 30,000	
	<b>Influent Pump Station</b>						\$ -	
	<b>Influent Pipeline</b>						\$ -	
	<b>Treatment Facilities</b>						\$ 30,000	
	Misc Metals			1	LS	\$ 30,000	\$ 30,000	
	<b>Distribution Pump Station</b>						\$ -	
	<b>Distribution Pipeline</b>						\$ -	
9 - Finishes							\$ 20,000	
	<b>Influent Pump Station</b>						\$ -	
	<b>Influent Pipeline</b>						\$ -	
	<b>Treatment Facilities</b>						\$ 20,000	
	Finishes Allowance			1	LS	\$ 20,000	\$ 20,000	
	<b>Distribution Pump Station</b>						\$ -	
	<b>Distribution Pipeline</b>						\$ -	
11 - Equipment							\$ 2,960,000	
	<b>Influent Pump Station</b>						\$ 390,000	
	Submersible Pumps	30	hp	2	EA	\$ 6,500	\$ 390,000	Estimate for complete pump station
	<b>Influent Pipeline</b>						\$ -	
	<b>Treatment Facilities</b>						\$ 2,480,000	
	Grit Removal			1	LS	\$ 150,000	\$ 150,000	Includes allowance for installation
	Screens and Washer Compactor			1	LS	\$ 340,000	\$ 340,000	Includes allowance for installation
	MBR Package			1	LS	\$ 1,280,000	\$ 1,280,000	Vendor quote
	MBR Equipment Installation			1	LS	\$ 320,000	\$ 320,000	25% of equipment cost
	UV Disinfection			1	LS	\$ 300,000	\$ 300,000	Includes allowance for installation
	Odor Control			1	LS	\$ 90,000	\$ 90,000	Includes allowance for installation
	<b>Distribution Pump Station</b>						\$ 90,000	
	Vertical Turbine Pumps (RW to Storage Ponds)			2	EA	\$ 20,000	\$ 40,000	
	Vertical Turbine Pumps (RW to Other Users)			2	EA	\$ 25,000	\$ 50,000	
	<b>Distribution Pipeline</b>						\$ -	
15 - Mechanical							\$ 40,000	
	<b>Influent Pump Station</b>						\$ -	
	<b>Influent Pipeline</b>						\$ -	
	<b>Treatment Facilities</b>						\$ 40,000	
	Misc. Mechanical			1	LS	\$ 40,000	\$ 40,000	
	<b>Distribution Pump Station</b>						\$ -	
	<b>Distribution Pipeline</b>						\$ -	
16 - Electrical							\$ 888,000	
	<b>Influent Pump Station</b>						\$ 117,000	
	Electrical Allowance					30%	\$ 117,000	30% of Division 11 (Equipment)
	<b>Influent Pipeline</b>						\$ -	
	<b>Treatment Facilities</b>						\$ 744,000	

	Electrical Allowance			30%	\$	744,000	30% of Division 11 (Equipment)
	<b>Distribution Pump Station</b>				\$	<b>27,000</b>	
	Electrical Allowance			30%	\$	27,000	30% of Division 11 (Equipment)
	<b>Distribution Pipeline</b>				\$	-	
<b>17 - I&amp;C</b>					\$	<b>592,000</b>	
	<b>Influent Pump Station</b>				\$	<b>78,000</b>	
	I&C Allowance			20%	\$	78,000	20% of Division 11 (Equipment)
	<b>Influent Pipeline</b>				\$	-	
	<b>Treatment Facilities</b>				\$	<b>496,000</b>	
	I&C Allowance			20%	\$	496,000	20% of Division 11 (Equipment)
	<b>Distribution Pump Station</b>				\$	<b>18,000</b>	
	Electrical Allowance			20%	\$	18,000	20% of Division 11 (Equipment)
	<b>Distribution Pipeline</b>				\$	-	
<b>ANNUAL O&amp;M COSTS</b>							
		<b>Amount</b>	<b>Unit</b>		<b>Value</b>		<b>Cost</b>
<b>Consumables</b>					<b>Total Consumables</b>	\$	<b>105,000</b>
	Equipment Consumables	\$ 2,960,000			2%	\$	59,200
	Electrical Consumables	\$ 888,000			2%	\$	17,760
	Instrumentation Consumables	\$ 592,000			2%	\$	11,840
	Pipeline Consumables	\$ 3,205,488			0.5%	\$	16,027
					<b>Total Power</b>	\$	<b>99,000</b>
<b>Power Costs</b>						\$	
	WW Pump Station	147,704	kwh	\$	0.15	\$	22,156
	<b>Headworks Screen</b>						
	Grit Screw	2722	kwh	\$	0.15	\$	408
	Grit Conveyor	227	kwh	\$	0.15	\$	34
	Headworks Screen	490	kwh	\$	0.15	\$	73
	<b>MBR</b>						
	Permeate Pumps	24799	kwh	\$	0.15	\$	3,720
	Recirculation Pumps	73189	kwh	\$	0.15	\$	10,978
	Denitrification Pumps	16079	kwh	\$	0.15	\$	2,412
	Membrane Blowers	27218	kwh	\$	0.15	\$	4,083
	Process Blowers	81654	kwh	\$	0.15	\$	12,248
	Anoxic Mixers	68045	kwh	\$	0.15	\$	10,207
	UV	27218	kwh	\$	0.15	\$	4,083
	<b>Effluent Pumping</b>						
	To Storage Pond	7290	kwh	\$	0.15	\$	1,094
	To SLAC	34,474	kwh	\$	0.15	\$	5,171
	<b>Chemicals</b>						
	Hypochlorite Dosing	5444	kwh	\$	0.15	\$	817
	Citric Acid Dosing	227	kwh	\$	0.15	\$	34
	<b>Odor Control</b>						
	Odor Control Fans	108872	kwh	\$	0.15	\$	16,331
	Site Electrical	36500	kwh	\$	0.15	\$	5,475
<b>Chemicals</b>					<b>Total Chemicals</b>	\$	<b>2,000</b>
	Hypochlorite	255	gal		\$1	\$	255
	Citric Acid	165	gal		\$4	\$	660
	Caustic	3	dry ton		\$450	\$	1,350
<b>Labor Costs</b>					<b>Total Labor</b>	\$	<b>52,000</b>
	Total # Operators	1	number				
	Average Annual Hours per operator	520	hrs/yr				Assume 16 hrs/wk, 6 mo of the year & 4 hrs/wk, 6 mo of the year
	Total Operators per year	520	Total hrs	\$	100	\$	<b>52,000</b>
<b>TOTAL ANNUAL O&amp;M COSTS</b>						<b>\$</b>	<b>258,000</b>



<b>16 - Electrical</b>					<b>\$ 888,000</b>		
	Influent Pump Station				\$ 117,000		
	Electrical Allowance	30%			\$ 117,000	30% of Division 11 (Equipment)	
	Influent Pipeline				\$ -		
	Treatment Facilities				\$ 744,000		
	Electrical Allowance	30%			\$ 744,000	30% of Division 11 (Equipment)	
	Distribution Pump Station				\$ 27,000		
	Electrical Allowance	30%			\$ 27,000	30% of Division 11 (Equipment)	
	Distribution Pipeline				\$ -		
<b>17 - I&amp;C</b>					<b>\$ 592,000</b>		
	Influent Pump Station				\$ 78,000		
	I&C Allowance	20%			\$ 78,000	20% of Division 11 (Equipment)	
	Influent Pipeline				\$ -		
	Treatment Facilities				\$ 496,000		
	I&C Allowance	20%			\$ 496,000	20% of Division 11 (Equipment)	
	Distribution Pump Station				\$ 18,000		
	Electrical Allowance	20%			\$ 18,000	20% of Division 11 (Equipment)	
	Distribution Pipeline				\$ -		
<b>ANNUAL O&amp;M COSTS</b>							
		<b>Amount</b>	<b>Unit</b>	<b>Value</b>	<b>Cost</b>		
<b>Consumables</b>					<b>Total Consumables</b>	<b>\$ 106,000</b>	
	Equipment Consumables	\$ 2,960,000			2%	\$ 59,200	2% of Equipment
	Electrical Consumables	\$ 888,000			2%	\$ 17,760	2% of Electrical
	Instrumentation Consumables	\$ 592,000			2%	\$ 11,840	2% of Instrumentation
	Pipeline Consumables	\$ 3,370,224			0.5%	\$ 16,851	0.5% of Pipeline
<b>Power Costs</b>					<b>Total Power</b>	<b>\$ 88,000</b>	
	WW Pump Station	98,263	kwh	\$	0.15	\$ 14,739	
	<b>Headworks Screen</b>						
	Grit Screw	2722	kwh	\$	0.15	\$ 408	
	Grit Conveyor	227	kwh	\$	0.15	\$ 34	
	Headworks Screen	490	kwh	\$	0.15	\$ 73	
	<b>MBR</b>						
	Permeate Pumps	17716	kwh	\$	0.15	\$ 2,657	
	Recirculation Pumps	73189	kwh	\$	0.15	\$ 10,978	
	Denitrification Pumps	16079	kwh	\$	0.15	\$ 2,412	
	Membrane Blowers	27218	kwh	\$	0.15	\$ 4,083	
	Process Blowers	81654	kwh	\$	0.15	\$ 12,248	
	Anoxic Mixers	68045	kwh	\$	0.15	\$ 10,207	
	UV	27218	kwh	\$	0.15	\$ 4,083	
	<b>Effluent Pumping</b>						
	To Storage Pond	7290	kwh	\$	0.15	\$ 1,094	
	To Sharon Land Co	2,961	kwh	\$	0.15	\$ 444	
	To Rosewood Sandhill and Sandhill Commons	12,856	kwh	\$	0.15	\$ 1,928	
	<b>Chemicals</b>						
	Hypochlorite Dosing	5444	kwh	\$	0.15	\$ 817	
	Citric Acid Dosing	227	kwh	\$	0.15	\$ 34	
	<b>Odor Control</b>						
	Odor Control Fans	108872	kwh	\$	0.15	\$ 16,331	
	Site Electrical	36500	kwh	\$	0.15	\$ 5,475	
<b>Chemicals</b>					<b>Total Chemicals</b>	<b>\$ 2,000</b>	
	Hypochlorite	255	gal		\$1	\$ 255	
	Citric Acid	165	gal		\$4	\$ 660	
	Caustic	3	dry ton		\$450	\$ 1,350	
<b>Labor Costs</b>					<b>Total Labor</b>	<b>\$ 52,000</b>	
	Total # Operators	1	number				
	Average Annual Hours per operator	520	hrs/yr				Assume 16 hrs/wk, 6 mo of the year & 4 hrs/wk, 6 mo of the year
	Total Operators per year	520	Total hrs	\$	100	\$ 52,000	
<b>TOTAL ANNUAL O&amp;M COSTS</b>						<b>\$ 248,000</b>	



<b>Treatment Facilities</b>					<b>\$ 516,750</b>	
	Electrical Allowance			30%	\$ 516,750	30% of Division 11 (Equipment)
<b>Distribution Pump Station</b>					<b>\$ 12,000</b>	
	Electrical Allowance			30%	\$ 12,000	30% of Division 11 (Equipment)
<b>Distribution Pipeline</b>						
<b>17 - I&amp;C</b>					<b>\$ 430,500</b>	
<b>Influent Pump Station</b>					<b>\$ 78,000</b>	
	I&C Allowance			20%	\$ 78,000	20% of Division 11 (Equipment)
<b>Influent Pipeline</b>						
<b>Treatment Facilities</b>					<b>\$ 344,500</b>	
	I&C Allowance			20%	\$ 344,500	20% of Division 11 (Equipment)
<b>Distribution Pump Station</b>					<b>\$ 8,000</b>	
	I&C Allowance			20%	\$ 8,000	20% of Division 11 (Equipment)
<b>Distribution Pipeline</b>						
<b>ANNUAL O&amp;M COSTS</b>		<b>Amount</b>	<b>Unit</b>		<b>Value</b>	<b>Cost</b>
<b>Consumables</b>					<b>Total Consumables \$ 76,000</b>	
	Equipment Consumables	\$ 2,152,500			2%	\$ 43,050 2% of Equipment
	Electrical Consumables	\$ 645,750			2%	\$ 12,915 2% of Electrical
	Instrumentation Consumables	\$ 430,500			2%	\$ 8,610 2% of Instrumentation
	Pipeline Consumables	\$ 2,381,808			0.5%	\$ 11,909 0.5% of Pipeline
<b>Power Costs</b>					<b>Total Power \$ 62,000</b>	
	WW Pump Station	75,848	kwh	\$	0.15	\$ 11,377
<b>Headworks Screen</b>						
	Grit Screw	2722	kwh	\$	0.15	\$ 408
	Grit Conveyor	227	kwh	\$	0.15	\$ 34
	Headworks Screen	490	kwh	\$	0.15	\$ 73
<b>SBR</b>						
	Mixers	25,517	kwh	\$	0.15	\$ 3,828
	Blowers	90,727	kwh	\$	0.15	\$ 13,609
	Transfer Pumps	3,442	kwh	\$	0.15	\$ 516
<b>Cloth Media Filtration</b>						
	Filter Drive	150	kwh	\$	0.15	\$ 22
	Filter Backwash Pumps	1,578	kwh	\$	0.15	\$ 237
	UV	27,218	kwh	\$	0.15	\$ 4,083
<b>Effluent Pumping</b>						
	To Storage Pond	7290	kwh	\$	0.15	\$ 1,094
<b>Chemicals</b>						
	Hypochlorite Dosing	5,444	kwh	\$	0.15	\$ 817
<b>Odor Control</b>						
	Odor Control Fans	136090	kwh	\$	0.15	\$ 20,414
	Site Electrical	36500	kwh	\$	0.15	\$ 5,475
<b>Chemicals</b>					<b>Total Chemicals \$ 300</b>	
	Hypochlorite	255	gal		\$1	\$ 255
<b>Labor Costs</b>					<b>Total Labor \$ 52,000</b>	
	Total # Operators	1	number			
	Average Annual Hours per operator	520	hrs/yr			Assume 16 hrs/wk, 6 mo of the year & 4 hrs/wk, 6 mo of the year
	Total Operators per year	520	Total hrs	\$	100	\$ 52,000
<b>TOTAL ANNUAL O&amp;M COSTS</b>					<b>\$</b>	<b>190,300</b>

**Project:** West Bay Sanitary District RW Facilities Plan  
**Alternative:** 2B - Sharon Heights Golf Course + SLAC  
**Treatment:** SBR + Cloth Media Filtration

Date: June 12, 2015  
 Project Number: 606-001

Prepared by: SAM  
 Checked by:

Avg Annual Demand (AFY) 236

Estimate Type: Conceptual Design

**Process Cost Summary by Division**

Spec. Division	Subtotal	Notes
2 - Sitework	\$ 3,209,194	
3 - Concrete	\$ 2,430,500	
5 - Metals	\$ 30,000	
9 - Finishes	\$ 20,000	
11 - Equipment	\$ 2,202,500	
15 - Mechanical	\$ 40,000	
16 - Electrical	\$ 660,750	
17- I&C	\$ 440,500	
	<b>RAW CONSTRUCTION COST \$ 9,033,000</b>	
	Construction Contingency 30% \$ 2,710,000	
	<b>BASE CONSTRUCTION COST \$ 11,740,000</b>	
	Environmental \$ 123,000	
	Permitting \$ 127,000	
	Design for PS, WW FM, Plant \$ 1,500,000	
	Design for Distribution Pipeline \$ 250,000	
	CM for PS and coveyance FM \$ 250,000	
	CM for Treatment Plant \$ 500,000	
	CM for Distribution Pipeline \$ 250,000	
	Financing \$ 100,000	
	<b>IMPLEMENTATION COST \$ 3,100,000</b>	
	5% \$ 587,000	
	<b>PROJECT CONTINGENCY \$ 587,000</b>	
	<b>TOTAL PROJECT COST \$ 15,430,000</b>	

Spec. Division	Item	Size	Units	Quantity	Unit	Unit Cost	Total Cost	Notes
<b>2 - Sitework</b>							<b>\$ 3,209,194</b>	
	Influent Pump Station Mobilization/Demobilization			\$ 585,000		5%	\$ 29,250	
	Influent Pipeline Mobilization/Demobilization			\$ 1,689,600		5%	\$ 84,480	
	Treatment Facilities Mobilization/Demobilization			\$ 5,263,080		5%	\$ 263,154	
	Distribution Pump Station Mobilization/Demobilization			\$ 432,000		5%	\$ 21,600	
	Distribution Pipeline Mobilization/Demobilization			\$ 633,600		5%	\$ 31,680	
	<b>Influent Pump Station</b>						\$ -	
	<b>Influent Pipeline</b>						\$ 1,689,600	
	8" Pipe, Forcemain from collection system	8	in	10,560	LF	\$ 160	\$ 1,689,600	Conveys raw wastewater to site
	<b>Treatment Facilities</b>						\$ 455,830	
	Site Clearing			1	Days	\$ 5,000	\$ 5,000	
	Excavation for SBR tanks			8,700	CY	\$ 10	\$ 87,000	89 ft x 62 ft x 10 ft, assume using existing pond.
	Excavation for effluent pump station wet well			2,200	CY	\$ 10	\$ 22,000	10 ft x 11 ft x 14 ft, assume 1:1 excavation
	Backfill			5,200	CY	\$ 7	\$ 36,692	
	Offhaul			10,900	CY	\$ 11	\$ 115,578	
	Dewatering			1	LS	\$ 20,000	\$ 20,000	
	Landscaping Allowance			1	LS	\$ 10,000	\$ 10,000	
	Misc site work			1	LS	\$ 15,000	\$ 15,000	
	Waste flows to sewer system, within Golf Course property	6	in	1,584	LF	\$ 90	\$ 142,560	Connects to existing sewer
	<b>Distribution Pump Station</b>						\$ -	
	<b>Distribution Pipeline</b>						\$ 633,600	
	Recycled water to SLAC	6	in	5,280	LF	\$ 120	\$ 633,600	
<b>3 - Concrete</b>							<b>\$ 2,430,500</b>	
	<b>Influent Pump Station</b>						\$ -	
	<b>Influent Pipeline</b>						\$ -	
	<b>Treatment Facilities</b>						\$ 2,133,500	
	SBR Tanks Slab			680	CY	\$ 600	\$ 408,000	92 ft x 67 ft, 3 ft thick
	SBR Tanks Elevated slab			460	CY	\$ 850	\$ 391,000	6200 sf, 2 ft thick
	SBR Tanks Walls			470	CY	\$ 1,200	\$ 564,000	18 ft high, 1.5 ft thick
	Treatment Building			6,164	SF	\$ 125	\$ 770,500	92 ft x 67 ft
	<b>Distribution Pump Station</b>						\$ 297,000	
	Slab			190	CY	\$ 600	\$ 114,000	58 ft x 29 ft, 3 ft thick
	Elevated slab			60	CY	\$ 850	\$ 51,000	57 ft x 28 ft, 1 ft thick
	Walls			110	CY	\$ 1,200	\$ 132,000	12 ft high, 1.5 ft thick
	<b>Distribution Pipeline</b>						\$ -	
<b>5 - Metals</b>							<b>\$ 30,000</b>	
	<b>Influent Pump Station</b>						\$ -	
	<b>Influent Pipeline</b>						\$ -	
	<b>Treatment Facilities</b>						\$ 30,000	
	Misc Metals			1	LS	\$ 30,000	\$ 30,000	
	<b>Distribution Pump Station</b>						\$ -	
	<b>Distribution Pipeline</b>						\$ -	
<b>9 - Finishes</b>							<b>\$ 20,000</b>	
	<b>Influent Pump Station</b>						\$ -	
	<b>Influent Pipeline</b>						\$ -	
	<b>Treatment Facilities</b>						\$ 20,000	
	Finishes Allowance			1	LS	\$ 20,000	\$ 20,000	
	<b>Distribution Pump Station</b>						\$ -	
	<b>Distribution Pipeline</b>						\$ -	
<b>11 - Equipment</b>							<b>\$ 2,202,500</b>	
	<b>Influent Pump Station</b>						\$ 390,000	
	Submersible Pumps	30	hp	2	EA	\$ 6,500	\$ 390,000	Estimate for complete pump station
	<b>Influent Pipeline</b>						\$ -	
	<b>Treatment Facilities</b>						\$ 1,722,500	
	Grit Removal			1	LS	\$ 150,000	\$ 150,000	Includes allowance for installation
	Screens and Washer Compactor			1	LS	\$ 300,000	\$ 300,000	Includes allowance for installation
	SBR Equipment Package			1	LS	\$ 540,000	\$ 540,000	Vendor quote
	Equipment Installation			1	LS	\$ 135,000	\$ 135,000	25% of equipment cost
	Sodium Hypochlorite Pump			1	EA	\$ 7,500	\$ 7,500	
	Cloth Media Filter			1	LS	\$ 200,000	\$ 200,000	Vendor quote
	UV Disinfection			1	LS	\$ 300,000	\$ 300,000	Includes allowance for installation
	Odor Control			1	LS	\$ 90,000	\$ 90,000	Includes allowance for installation
	<b>Distribution Pump Station</b>						\$ 90,000	
	Vertical Turbine Pumps (RW to Storage Ponds)			2	EA	\$ 20,000	\$ 40,000	
	Vertical Turbine Pumps (RW to SLAC)			2	EA	\$ 25,000	\$ 50,000	
	<b>Distribution Pipeline</b>						\$ -	
<b>15 - Mechanical</b>							<b>\$ 40,000</b>	
	<b>Influent Pump Station</b>						\$ -	
	<b>Influent Pipeline</b>						\$ -	
	<b>Treatment Facilities</b>						\$ 40,000	
	Misc. Mechanical			1	LS	\$ 40,000	\$ 40,000	
	<b>Distribution Pump Station</b>						\$ -	
	<b>Distribution Pipeline</b>						\$ -	
<b>16 - Electrical</b>							<b>\$ 660,750</b>	
	<b>Influent Pump Station</b>						\$ 117,000	
	Electrical Allowance					30%	\$ 117,000	30% of Division 11 (Equipment)



	Influent Pipeline			\$	-		
	Treatment Facilities			\$	516,750		
	Electrical Allowance			30% \$	516,750	30% of Division 11 (Equipment)	
	Distribution Pump Station			\$	27,000		
	Electrical Allowance			30% \$	27,000	30% of Division 11 (Equipment)	
	Distribution Pipeline			\$	-		
<b>17 - I&amp;C</b>				\$	<b>440,500</b>		
	Influent Pump Station			\$	78,000		
	I&C Allowance			20% \$	78,000	20% of Division 11 (Equipment)	
	Influent Pipeline			\$	-		
	Treatment Facilities			\$	344,500		
	I&C Allowance			20% \$	344,500	20% of Division 11 (Equipment)	
	Distribution Pump Station			\$	18,000		
	Electrical Allowance			20% \$	18,000	20% of Division 11 (Equipment)	
	Distribution Pipeline			\$	-		
<b>ANNUAL O&amp;M COSTS</b>							
		<b>Amount</b>	<b>Unit</b>		<b>Value</b>		<b>Cost</b>
<b>Consumables</b>					Total Consumables \$		<b>38,000</b>
	Equipment Consumables	\$ 2,202,500			2%		2% of Equipment
	Electrical Consumables	\$ 660,750			2%	\$ 13,215	2% of Electrical
	Instrumentation Consumables	\$ 440,500			2%	\$ 8,810	2% of Instrumentation
	Pipeline Consumables	\$ 3,205,488			0.5%	\$ 16,027	0.5% of Pipeline
<b>Power Costs</b>					Total Power \$		<b>78,000</b>
	WW Pump Station	147,704	kwh	\$	0.15	\$ 22,156	
	<b>Headworks Screen</b>						
	Grit Screw	2722	kwh	\$	0.15	\$ 408	
	Grit Conveyor	227	kwh	\$	0.15	\$ 34	
	Headworks Screen	490	kwh	\$	0.15	\$ 73	
	<b>SBR</b>						
	Mixers	25,517	kwh	\$	0.15	\$ 3,828	
	Blowers	90,727	kwh	\$	0.15	\$ 13,609	
	Transfer Pumps	3,442	kwh	\$	0.15	\$ 516	
	<b>Cloth Media Filtration</b>						
	Filter Drive	150	kwh	\$	0.15	\$ 22	
	Filter Backwash Pumps	1,578	kwh	\$	0.15	\$ 237	
	UV	27,218	kwh	\$	0.15	\$ 4,083	
	<b>Effluent Pumping</b>						
	To Storage Pond	7290	kwh	\$	0.15	\$ 1,094	
	To SLAC	34,474	kwh	\$	0.15	\$ 5,171	
	<b>Chemicals</b>						
	Hypochlorite Dosing	5,444	kwh	\$	0.15	\$ 817	
	<b>Odor Control</b>						
	Odor Control Fans	136090	kwh	\$	0.15	\$ 20,414	
	Site Electrical	36500	kwh	\$	0.15	\$ 5,475	
<b>Chemicals</b>					Total Chemicals \$		<b>300</b>
	Hypochlorite	255	gal		\$1	\$ 255	
<b>Labor Costs</b>					Total Labor \$		<b>52,000</b>
	Total # Operators	1	number				
	Average Annual Hours per operator	520	hrs/yr				Assume 16 hrs/wk, 6 mo of the year & 4 hrs/wk, 6 mo of the year
	Total Operators per year	520	Total hrs	\$	100	\$ 52,000	
<b>TOTAL ANNUAL O&amp;M COSTS</b>							<b>\$ 168,300</b>



Distribution Pipeline				\$	-	
<b>16 - Electrical</b>				\$	<b>648,750</b>	
Influent Pump Station				\$	<b>117,000</b>	
Electrical Allowance		30%	\$	117,000		30% of Division 11 (Equipment)
Influent Pipeline				\$	-	
Treatment Facilities				\$	<b>516,750</b>	
Electrical Allowance		30%	\$	516,750		30% of Division 11 (Equipment)
Distribution Pump Station				\$	<b>15,000</b>	
Electrical Allowance		30%	\$	15,000		30% of Division 11 (Equipment)
Distribution Pipeline				\$	-	
<b>17 - I&amp;C</b>				\$	<b>432,500</b>	
Influent Pump Station				\$	<b>78,000</b>	
I&C Allowance		20%	\$	78,000		20% of Division 11 (Equipment)
Influent Pipeline				\$	-	
Treatment Facilities				\$	<b>344,500</b>	
I&C Allowance		20%	\$	344,500		20% of Division 11 (Equipment)
Distribution Pump Station				\$	<b>10,000</b>	
Electrical Allowance		20%	\$	10,000		20% of Division 11 (Equipment)
Distribution Pipeline				\$	-	
<b>ANNUAL O&amp;M COSTS</b>						
<b>Consumables</b>		<b>Amount</b>	<b>Unit</b>	<b>Value</b>	<b>Cost</b>	
				Total Consumables	\$	<b>83,000</b>
Equipment Consumables		\$ 2,202,500		2%	\$	44,050 2% of Equipment
Electrical Consumables		\$ 648,750		2%	\$	12,975 2% of Electrical
Instrumentation Consumables		\$ 432,500		2%	\$	8,650 2% of Instrumentation
Pipeline Consumables		\$ 3,370,224		0.5%	\$	16,851 0.5% of Pipeline
<b>Power Costs</b>				Total Power	\$	<b>68,000</b>
WW Pump Station		98,263	kwh	\$	0.15	\$ 14,739
<b>Headworks Screen</b>						
Grit Screw		2722	kwh	\$	0.15	\$ 408
Grit Conveyor		227	kwh	\$	0.15	\$ 34
Headworks Screen		490	kwh	\$	0.15	\$ 73
<b>SBR</b>						
Mixers		25,517	kwh	\$	0.15	\$ 3,828
Blowers		90,727	kwh	\$	0.15	\$ 13,609
Transfer Pumps		3,442	kwh	\$	0.15	\$ 516
<b>Cloth Media Filtration</b>						
Filter Drive		150	kwh	\$	0.15	\$ 22
Filter Backwash Pumps		1,578	kwh	\$	0.15	\$ 237
UV		27,218	kwh	\$	0.15	\$ 4,083
<b>Effluent Pumping</b>						
To Storage Pond		7290	kwh	\$	0.15	\$ 1,094
To Sharon Land Co		2,961	kwh	\$	0.15	\$ 444
To Rosewood Sandhill and Sandhill Commons		12,856	kwh	\$	0.15	\$ 1,928
<b>Chemicals</b>						
Hypochlorite Dosing		5,444	kwh	\$	0.15	\$ 817
<b>Odor Control</b>						
Odor Control Fans		136090	kwh	\$	0.15	\$ 20,414
Site Electrical		36500	kwh	\$	0.15	\$ 5,475
<b>Chemicals</b>				Total Chemicals	\$	<b>300</b>
Hypochlorite		255	gal		\$1	\$ 255
<b>Labor Costs</b>				Total Labor	\$	<b>52,000</b>
	Total # Operators	1	number			
	Average Annual Hours per operator	520	hrs/yr			Assume 16 hrs/wk, 6 mo of the year & 4 hrs/wk, 6 mo of the year
	Total Operators per year	520	Total hrs	\$	100	\$ 52,000
<b>TOTAL ANNUAL O&amp;M COSTS</b>					\$	<b>203,300</b>



<b>Treatment Facilities</b>				<b>\$ 549,750</b>	
Electrical Allowance			30%	\$ 549,750	30% of Division 11 (Equipment)
<b>Distribution Pump Station</b>				<b>\$ 12,000</b>	
Electrical Allowance			30%	\$ 12,000	30% of Division 11 (Equipment)
<b>Distribution Pipeline</b>					
<b>17 - I&amp;C</b>				<b>\$ 452,500</b>	
<b>Influent Pump Station</b>				<b>\$ 78,000</b>	
I&C Allowance			20%	\$ 78,000	20% of Division 11 (Equipment)
<b>Influent Pipeline</b>					
<b>Treatment Facilities</b>				<b>\$ 366,500</b>	
I&C Allowance			20%	\$ 366,500	20% of Division 11 (Equipment)
<b>Distribution Pump Station</b>				<b>\$ 8,000</b>	
I&C Allowance			20%	\$ 8,000	20% of Division 11 (Equipment)
<b>Distribution Pipeline</b>					
<b>ANNUAL O&amp;M COSTS</b>					
		<b>Amount</b>	<b>Unit</b>	<b>Value</b>	<b>Cost</b>
<b>Consumables</b>				<b>Total Consumables \$ 80,000</b>	
Equipment Consumables		\$ 2,262,500		2%	\$ 45,250 2% of Equipment
Electrical Consumables		\$ 678,750		2%	\$ 13,575 2% of Electrical
Instrumentation Consumables		\$ 452,500		2%	\$ 9,050 2% of Instrumentation
Pipeline Consumables		\$ 2,381,808		0.5%	\$ 11,909 0.5% of Pipeline
<b>Power Costs</b>				<b>Total Power \$ 66,000</b>	
WW Pump Station		75,848	kwh \$	0.15 \$	11,377
<b>Headworks Screen</b>					
Grit Screw		2722	kwh \$	0.15 \$	408
Grit Conveyor		227	kwh \$	0.15 \$	34
Headworks Screen		490	kwh \$	0.15 \$	73
<b>SBR</b>					
Mixers		25,517	kwh \$	0.15 \$	3,828
Blowers		90,727	kwh \$	0.15 \$	13,609
Transfer Pumps		3,442	kwh \$	0.15 \$	516
Sand Filters Air compressor		27,218	kwh \$	0.15 \$	4,083
UV		27,218	kwh \$	0.15 \$	4,083
<b>Effluent Pumping</b>					
To Storage Pond		7290	kwh \$	0.15 \$	1,094
<b>Chemicals</b>					
Hypochlorite Dosing		5,444	kwh \$	0.15 \$	817
<b>Odor Control</b>					
Odor Control Fans		136090	kwh \$	0.15 \$	20,414
Site Electrical		36500	kwh \$	0.15 \$	5,475
<b>Chemicals</b>				<b>Total Chemicals \$ 300</b>	
Hypochlorite		255	gal	\$1 \$	255
<b>Labor Costs</b>				<b>Total Labor \$ 52,000</b>	
		<b>Total # Operators</b>	1	number	
		<b>Average Annual Hours per operator</b>	520	hrs/yr	
		<b>Total Operators per year</b>	520	Total hrs \$	100 \$ 52,000
					Assume 16 hrs/wk, 6 mo of the year & 4 hrs/wk, 6 mo of the year
<b>TOTAL ANNUAL O&amp;M COSTS</b>					<b>\$ 198,300</b>



Distribution Pipeline					\$	-
<b>16 - Electrical</b>					\$	<b>693,750</b>
	Influent Pump Station				\$	<b>117,000</b>
	Electrical Allowance	30%			\$	117,000 30% of Division 11 (Equipment)
	Influent Pipeline				\$	-
	Treatment Facilities				\$	<b>549,750</b>
	Electrical Allowance	30%			\$	549,750 30% of Division 11 (Equipment)
	Distribution Pump Station				\$	<b>27,000</b>
	Electrical Allowance	30%			\$	27,000 30% of Division 11 (Equipment)
	Distribution Pipeline				\$	-
<b>17 - I&amp;C</b>					\$	<b>462,500</b>
	Influent Pump Station				\$	<b>78,000</b>
	I&C Allowance	20%			\$	78,000 20% of Division 11 (Equipment)
	Influent Pipeline				\$	-
	Treatment Facilities				\$	<b>366,500</b>
	I&C Allowance	20%			\$	366,500 20% of Division 11 (Equipment)
	Distribution Pump Station				\$	<b>18,000</b>
	Electrical Allowance	20%			\$	18,000 20% of Division 11 (Equipment)
	Distribution Pipeline				\$	-
<b>ANNUAL O&amp;M COSTS</b>						
<b>Consumables</b>		<b>Amount</b>	<b>Unit</b>	<b>Value</b>		<b>Cost</b>
				Total Consumables	\$	<b>85,000</b>
	Equipment Consumables	\$ 2,312,500		2%	\$	46,250 2% of Equipment
	Electrical Consumables	\$ 693,750		2%	\$	13,875 2% of Electrical
	Instrumentation Consumables	\$ 462,500		2%	\$	9,250 2% of Instrumentation
	Pipeline Consumables	\$ 3,205,488		0.5%	\$	16,027 0.5% of Pipeline
<b>Power Costs</b>				Total Power	\$	<b>82,000</b>
	WW Pump Station	147,704	kwh	0.15	\$	22,156
	<b>Headworks Screen</b>					
	Grit Screw	2722	kwh	0.15	\$	408
	Grit Conveyor	227	kwh	0.15	\$	34
	Headworks Screen	490	kwh	0.15	\$	73
	<b>SBR</b>					
	Mixers	25,517	kwh	0.15	\$	3,828
	Blowers	90,727	kwh	0.15	\$	13,609
	Transfer Pumps	3,442	kwh	0.15	\$	516
	Sand Filters Air compressor	27,218	kwh	0.15	\$	4,083
	UV	27,218	kwh	0.15	\$	4,083
	<b>Effluent Pumping</b>					
	To Storage Pond	7290	kwh	0.15	\$	1,094
	To SLAC	34,474	kwh	0.15	\$	5,171
	<b>Chemicals</b>					
	Hypochlorite Dosing	5,444	kwh	0.15	\$	817
	<b>Odor Control</b>					
	Odor Control Fans	136090	kwh	0.15	\$	20,414
	Site Electrical	36500	kwh	0.15	\$	5,475
<b>Chemicals</b>				Total Chemicals	\$	<b>300</b>
	Hypochlorite	255	gal	\$1	\$	255
<b>Labor Costs</b>				Total Labor	\$	<b>52,000</b>
	Total # Operators	1	number			
	Average Annual Hours per operator	520	hrs/yr			Assume 16 hrs/wk, 6 mo of the year & 4 hrs/wk, 6 mo of the year
	Total Operators per year	520	Total hrs	\$	100	<b>52,000</b>
<b>TOTAL ANNUAL O&amp;M COSTS</b>					\$	<b>219,300</b>





Distribution Pipeline				\$	-	
<b>16 - Electrical</b>				\$	<b>693,750</b>	
	Influent Pump Station			\$	117,000	
	Electrical Allowance	30%	\$	117,000	30% of Division 11 (Equipment)	
	Influent Pipeline			\$	-	
	Treatment Facilities			\$	549,750	
	Electrical Allowance	30%	\$	549,750	30% of Division 11 (Equipment)	
	Distribution Pump Station			\$	27,000	
	Electrical Allowance	30%	\$	27,000	30% of Division 11 (Equipment)	
	Distribution Pipeline			\$	-	
<b>17 - I&amp;C</b>				\$	<b>462,500</b>	
	Influent Pump Station			\$	78,000	
	I&C Allowance	20%	\$	78,000	20% of Division 11 (Equipment)	
	Influent Pipeline			\$	-	
	Treatment Facilities			\$	366,500	
	I&C Allowance	20%	\$	366,500	20% of Division 11 (Equipment)	
	Distribution Pump Station			\$	18,000	
	Electrical Allowance	20%	\$	18,000	20% of Division 11 (Equipment)	
	Distribution Pipeline			\$	-	
<b>ANNUAL O&amp;M COSTS</b>						
<b>Consumables</b>		<b>Amount</b>	<b>Unit</b>	<b>Value</b>	<b>Cost</b>	
				Total Consumables	\$	<b>86,000</b>
	Equipment Consumables	\$ 2,312,500		2%	\$	46,250 2% of Equipment
	Electrical Consumables	\$ 693,750		2%	\$	13,875 2% of Electrical
	Instrumentation Consumables	\$ 462,500		2%	\$	9,250 2% of Instrumentation
	Pipeline Consumables	\$ 3,370,224		0.5%	\$	16,851 0.5% of Pipeline
<b>Power Costs</b>				Total Power	\$	<b>72,000</b>
	WW Pump Station	98,263	kwh	\$	0.15	\$ 14,739
	<b>Headworks Screen</b>					
	Grit Screw	2722	kwh	\$	0.15	\$ 408
	Grit Conveyor	227	kwh	\$	0.15	\$ 34
	Headworks Screen	490	kwh	\$	0.15	\$ 73
	<b>SBR</b>					
	Mixers	25,517	kwh	\$	0.15	\$ 3,828
	Blowers	90,727	kwh	\$	0.15	\$ 13,609
	Transfer Pumps	3,442	kwh	\$	0.15	\$ 516
	Sand Filters Air compressor	27,218	kwh	\$	0.15	\$ 4,083
	UV	27,218	kwh	\$	0.15	\$ 4,083
	<b>Effluent Pumping</b>					
	To Storage Pond	7290	kwh	\$	0.15	\$ 1,094
	To Sharon Land Co	2,961	kwh	\$	0.15	\$ 444
	To Rosewood Sandhill and Sandhill Commons	12,856	kwh	\$	0.15	\$ 1,928
	<b>Chemicals</b>					
	Hypochlorite Dosing	5,444	kwh	\$	0.15	\$ 817
	<b>Odor Control</b>					
	Odor Control Fans	136090	kwh	\$	0.15	\$ 20,414
	Site Electrical	36500	kwh	\$	0.15	\$ 5,475
<b>Chemicals</b>				Total Chemicals	\$	<b>300</b>
	Hypochlorite	255	gal		\$1	\$ 255
<b>Labor Costs</b>				Total Labor	\$	<b>52,000</b>
	Total # Operators	1	number			
	Average Annual Hours per operator	520	hrs/yr			Assume 16 hrs/wk, 6 mo of the year & 4 hrs/wk, 6 mo of the year
	Total Operators per year	520	Total hrs	\$	100	\$ <b>52,000</b>
<b>TOTAL ANNUAL O&amp;M COSTS</b>					\$	<b>210,300</b>

## **Appendix E - Environmental Checklist**

---

## **Introduction**

The purpose of this preliminary evaluation is to identify expected environmental impacts from implementation (construction and operation) of the West Bay Sanitary District's Recycled Water Recommended Project. In addition, this analysis is intended to help the City determine the level of environmental documentation that will be needed at the next stage of CEQA environmental review. The environmental topics discussed in this document are based on Appendix G of the CEQA Guidelines. The anticipated environmental impacts are identified for each resource area. The level of significance for each resource area uses CEQA terminology as specified below:

- No Impact;
- Less than Significant;
- Less than Significant Impact with Mitigation Incorporation; and
- Potentially Significant Impact.

## **Project Description**

Chapter 8 of the Recycled Water Facility Plan provides a discussion of the Recycled Water Recommended Project. The figures in that section identify the locations of the proposed facilities within the Sharon Heights Golf & Country Club property and the proposed pipeline alignments within the City of Menlo Park's boundaries. For the purposes of this preliminary analysis, it is assumed that construction activities would involve grading, excavation, erection of facilities, installation of pipelines using open-trench construction, and backfilling. Typical construction equipment would be used, including but not limited to bulldozers, backhoes, water trucks, dump trucks, excavators, and concrete trucks. Construction activities would likely last for one year overall but would be less for each component (e.g., treatment facilities and the proposed pipeline segments). Details of the construction scenarios will be developed as the project progresses into design, and will be evaluated in more depth in the upcoming environmental analysis. The following preliminary analysis is based on the current understanding of the project construction and operation as described in Chapter 8 of the Recycled Water Facility Plan. This analysis shows that the majority of the impacts would be less than significant. Where potential significant impacts are anticipated, they would be reduced to less than significant with implementation of mitigation measures that will be further developed during the CEQA process. No significant, unavoidable impacts have been identified.

Environmental Topics	Expected Impact	Discussion of Major, Potential Environmental Effects
<b>Aesthetics</b>		
Adverse effect on a scenic vista	LTS	<ul style="list-style-type: none"> <li>The City of Menlo Park has identified stretch of Sand Hill Road from Santa Cruz Avenue to Highway 280 as a View Corridor. Impacts to the View Corridor are minimized to less than significant by the low profile of planned project facilities, screening structures and coverage provided by trees between the project and Sand Hill Road.</li> <li>Construction of all proposed facilities would temporarily alter the visual quality of the affected area due to the presence of construction equipment, but would not result in any permanent visual changes.</li> <li>Proposed pipelines would ultimately be buried underground and out of sight. No visual impacts would occur.</li> <li>Within the Project area, there is one officially designated State Scenic Highway (I-280) located immediately adjacent (to the west) to the Project. Impacts to the scenic resources are minimized to less than significant by the low profile of the Project, the size of the treatment plant, the speed of traffic on I-280, screening structures and coverage provided by trees between the Project and I-280.</li> </ul>
Substantial damage to scenic resources, including trees, rock outcroppings or historic buildings within a state scenic highway	LTSM	
Substantial degradation of the existing visual character or quality of the site and its surroundings	LTSM	
Creation of a new source of substantial light or glare which would adversely affect day or nighttime views in the area	LTS	
<b>Agricultural and Forestry Resources</b>		
Conversion of Prime Farmland, Unique Farmland or Farmland of Statewide Important (Farmland) or conflict with existing zoning for agricultural use of a Williamson Act contract	NI	<ul style="list-style-type: none"> <li>The Study Area falls entirely within Urban/Built and Other land designations. There are no Farmlands or forestry resources within the Study Area.</li> </ul>
Loss of forest land or conversion of forest land to non-forest land or change in the existing environment which could result in conversion of Farmland to non-agricultural use or conversion of forest land to non-forest use	NI	
<b>Air Quality</b>		
Conflict with or obstruction of implementation of the applicable air quality plan or cumulative considerable net increase of any criteria pollutant for	LTSM	<ul style="list-style-type: none"> <li>Construction activities would generate dust and criteria pollutant emissions that could, but are not expected to, exceed Bay Area Air Quality Management District (BAAQMD) standards. These emissions have not yet been quantified.</li> </ul>

Environmental Topics	Expected Impact	Discussion of Major, Potential Environmental Effects
which the project region is nonattainment		<ul style="list-style-type: none"> <li>Excavation and hauling trips could generate criteria pollutant emissions that exceed BAAQMD thresholds and result in a potentially significant impact. Mitigation measures could include implementation of dust control measures, sequencing (phasing) work to reduce daily emissions (including preconstruction grading to prepare the site), and/or requiring contractors to implement best available control technology for construction equipment. Air quality modeling would be conducted during the next stage of CEQA review to confirm this conclusion.</li> </ul>
Violation of any air quality standard or substantial contribution to an existing or projected air quality violation	LTSM	
Exposure of sensitive receptors to substantial pollutant concentrations	LTS	
Creation of objectionable odors affecting a substantial number of people	LTSM	<ul style="list-style-type: none"> <li>Operation of the Proposed Project is expected to generate minimal emissions from chemical delivery truck trips and operation of the satellite treatment facility. Based on the number of truck trips and existing assumptions, operational-related air quality impacts are anticipated to be less than significant.</li> <li>Trinity School, Stanford Hills Park and some residential units are located along the alignment of the Proposed Project influent supply pipe. Given the short duration of construction, and mitigation measures that would be implemented as described above to reduce dust, sensitive receptors at the school and at nearby residences are not expected to be exposed to substantial pollutant concentrations.</li> <li>Potential objectionable odors may occur treatment facility during operation. However, biological basins would be constructed below grade, with covers at grade level for odor control. With this mitigation measure in place, and the relatively small size of the treatment facility, impacts from operation are expected to be less than significant.</li> <li>There is also potential for some objectionable odors during construction (e.g., diesel fuel), but these would be temporary in nature and considered less than significant.</li> </ul>
<b>Biological Resources</b>		
Effects on candidate, sensitive, or special status species or sensitive habitat	LTSM	<ul style="list-style-type: none"> <li>A California Natural Diversity Database (CNDDDB) search for sensitive resources was conducted for information regarding the locations of known observations of Federal and State-listed sensitive species and habitats in the vicinity of the Project area. Information on wetlands, creeks, and/or other water bodies was derived from the U.S. Fish and Wildlife Service's Wetland Digital Database. Biological resources surveys have not been completed for this preliminary analysis.</li> <li>Impacts to terrestrial biological resources from the Proposed Project are expected to be minimal. No critical habitat occurs in and around the Proposed Project (USFWS, 2015a); although nearby trees and shrubs may provide habitat for birds and other species. A field reconnaissance survey is still needed. Mitigation measures (such as restriction on the</li> </ul>
Substantial interference with the movement of fish or wildlife species, their or native wildlife nursery sites	LTS	
Substantial adverse effect on any riparian habitat or other sensitive natural community identified in local or regional plans, policies, and regulations or by the California	LTS	

Environmental Topics	Expected Impact	Discussion of Major, Potential Environmental Effects
Department of Fish and Game or U.S. Fish and Wildlife Service		<p>timing of construction) are expected to be available to reduce any impacts to terrestrial biological resources to less than significant.</p>
Substantial adverse effect on federally protected wetlands as defined by Section 404 of the Clean Water Act	LTS	<ul style="list-style-type: none"> <li>• Operation of the Proposed Project is not expected to result in any significant impacts on special-status aquatic resources. Potential impacts to aquatic biological resources from the Proposed Project would be less than significant, and no additional mitigation would be required.</li> </ul>
Conflict with any local plans, policies or ordinances protecting biological resources	LTSM	<ul style="list-style-type: none"> <li>• There are no creeks in or near the project area.</li> </ul>
Conflict with provisions of an adopted Habitat Conservation Plan, Natural Community Conservation Plan or other approved local, regional or state habitat conservation plan	NI	<ul style="list-style-type: none"> <li>• The disposal pipeline would be constructed within roadway ROWs, and is not expected to interfere with wildlife movement. Menlo Park does not have any Priority Conservation Areas and construction of the treatment facility is not anticipated to affect wildlife movement.</li> <li>• Some trees would be removed for construction of the treatment facility. All such trees are located within the property line of the Sharon Heights Golf Course. To the extent possible, trees that currently provide screening between residences, Highway 280 and the treatment facility would remain in place. It is anticipated that only non-heritage trees and shrubs would be removed. If heritage trees must be removed, then appropriate mitigation measures, consistent with the City of Menlo Park's tree removal policy, shall be implemented to reduce impacts to less than significant.</li> <li>• The Proposed Project would not be sited in any of the areas designated by the Midpeninsula Regional Open Space District as Priority Conservation Areas.</li> </ul>
<b>Cultural Resources</b>		
Alteration of or damage to cultural resources (i.e., historical and archaeological resources, including human remains, and paleontological resources)	LTSM	<ul style="list-style-type: none"> <li>• No cultural resources study or records search through the Northwest Information Center for the California Historical Research Information System, or reconnaissance survey were conducted as part of this preliminary analysis.</li> <li>• The Cultural Resources Inventory Report has not yet been conducted but would be completed as part of future CEQA review. Because of the potential for unrecorded cultural resources sites to be found during excavation activities, impacts to cultural resources would be considered significant. However, mitigation measures are available to reduce potential impacts to less than significant levels.</li> </ul>

Environmental Topics	Expected Impact	Discussion of Major, Potential Environmental Effects
<b>Geology, Soils and Seismicity</b>		
Exposure of people or structures to potential substantial adverse effects, including the risk of loss, injury, or death involving seismic risks or landslides	LTSM	<ul style="list-style-type: none"> <li>Proposed facilities are not habitable structures.</li> <li>The City of Menlo Park is located adjacent to the San Andreas Fault. The Alquist-Priolo map for the region indicates that the proposed project site is within fault zones, landslide and liquefaction zones. None of the Proposed Project components would cross a known fault line or otherwise expose people or structures to ruptures of a known fault. However, there is potential for exposure to ground shaking.</li> <li>Shaking hazard maps show the Study Area is at risk for very strong shaking. Due to the Proposed Project's location, it would be subject to design and construction regulations</li> </ul>
Substantial soil erosion or the loss of topsoil	LTSM	
Exposure of people or structures to unstable or expansive soils	LTSM	

Environmental Topics	Expected Impact	Discussion of Major, Potential Environmental Effects
Soils incapable of adequately supporting the use of septic tanks or alternative wastewater disposals systems where sewers are not available	LTS	<p>compliant with the 2013 California Building Code. This compliance would reduce the risks associated with seismic activities to less than significant levels.</p> <ul style="list-style-type: none"> <li>• Liquefaction mapping from U.S. Geological Survey (USGS) shows that the Study Area is primarily within no or low liquefaction susceptibility areas. Additional compliance with applicable codes, regulations, and standards would reduce risks to the Proposed Project from liquefaction to less than significant.</li> <li>• Soil erosion is possible during construction, particularly due to grading activities at the treatment facility site. Implementation of typical Best Management Practices (BMPs) and the required SWPPP would reduce the potential risk for soil erosion or loss. Additional mitigation measures may be required to reduce the risk of soil loss during grading or other construction activities.</li> <li>• The waste disposal pipeline component of the Proposed Project would not affect the stability of the geologic unit or soil, or result in on- or off-site landslides, lateral spreading, subsidence, liquefaction, or collapse. The grading and excavation required for the treatment facility could create the potential for collapse or on-site landslide, but with the installation of the retaining wall, geotechnical investigation for the retaining wall and treatment facilities, and proper engineering and compliance with all applicable codes and regulations, potential impacts is expected to be reduced to less than significant.</li> <li>• Portions of the Study Area are located in clay loam soils, which have some potential for expansion. Mitigation measures, including preparation of a geotechnical study and implementation of its recommended measures, would reduce the potential for unstable soils to adversely affect the Proposed Project.</li> <li>• The Proposed Project includes wastewater treatment for non-potable reuse, but does not include septic-related waste. Sewers are available in the project vicinity for waste, including waste from the treatment processes.</li> </ul>
<b>Greenhouse Gas Emissions</b>		
Generation of greenhouse gas emissions that may have a significant impact on the environment	LTSM	
Conflict with an applicable plan, policy or regulation adopted for the purpose of reducing the emissions of greenhouse gases	LTSM	<ul style="list-style-type: none"> <li>• Air quality modeling has not been conducted for the proposed Project. Operation of the treatment facility (including chemical trip deliveries) is expected to generate greenhouse gas emissions, but is not anticipated to exceed BAAQMD thresholds. Air quality modeling would be conducted in the next stage of CEQA review to confirm the results.</li> </ul>
<b>Hazards and Hazardous Materials</b>		



Environmental Topics	Expected Impact	Discussion of Major, Potential Environmental Effects
Creation of a significant hazard to the public or the environment through the routine transport, use, or disposal of hazardous materials; or accident involving the release of hazardous materials into the environment	LTSM	<ul style="list-style-type: none"> <li>Construction would not require the long-term routine transport, use, or disposal of hazardous materials. However, hazardous materials and substances such as diesel fuel would be transported to, handled and used at the construction sites and could present a hazard to the public or the environment through their accidental release. One school is located within one-quarter mile of the proposed work sites. With mitigation, such as the preparation and implementation of a Health and Safety Plan and a Hazardous Materials Management and Spill Prevention Plan and Control Plan, potential impacts would be reduced to less than significant.</li> <li>Operation of the treatment facility would require the long-term routine transport and use of hazardous materials and substances for treatment, cleaning, and other operation and maintenance purposes. Chemicals that would be transported to and/or from, and used at, the proposed treatment facility may include anionic or nonionic emulsion polymer, lubrication oils, grease, sodium hypochlorite, aqueous ammonia, ferric chloride, sodium bisulfite, antiscalent, carbon dioxide, carbonic acid, caustic soda, citric acid, fluorosilicic acid, and lime. All of the chemical facilities would be stored in double containment to ensure protection in the event of an accidental spill, and the depth of the tanks relative to the surrounding terrain would afford extra protection in the event of an accidental spill. Because Trinity School and some residences are within one-quarter mile of the treatment facility, impacts associated with the accidental release of hazardous materials are considered potentially significant. However, with the mitigation measures described above and compliance with the City's Emergency Operation Plan, the risk of hazardous materials release is low, and potential impacts would be reduced to less than significant.</li> <li>Based on a review of the California Department of Toxic Substances Control's (DTSC's) EnviroStor database, the Proposed Project's components would not be located on or near a site that is included on a list of hazardous materials sites compiled pursuant to Government Code Section 65962.5 (Cortese List).</li> <li>The Study Area does not include any airports. The nearest airport to the Study Area is in the City of Palo Alto, six miles northeast of the Proposed Project. As such, the Proposed Project would not expose people residing or working in the area to safety hazards.</li> <li>Construction activities for the proposed influent and waste disposal pipelines may require temporary lane or road closures that could impede emergency responses. Mitigation Measures, such as a Traffic Management Plan would be required, and would address any potential interference with emergency response and/or evacuation plans, and would reduce these impacts to less than significant.</li> </ul>
Emission or handling of hazardous materials, substances, or waste within one-quarter mile of an existing or proposed school.	LTSM	
Located on a site which is included on a list of hazardous materials sites compiled pursuant to Government Code Section 65962.5	LTSM	
Located within two miles of a public airport or private airstrip and result in a safety hazard for people residing or working in the project area.	NI	
Impair implementation of or physically interfere with an adopted emergency response plan or emergency evacuation plan	LTSM	
Exposure of people or structures to significant risk of loss, injury or death involving wildland fires	NI	

Environmental Topics	Expected Impact	Discussion of Major, Potential Environmental Effects
		<ul style="list-style-type: none"> <li>The Study Area is not at risk of wildland fires; therefore there would be no impact for risks associated with wildland fires and fires in urban-wildland interface areas.</li> </ul>
<b>Hydrology and Water Quality</b>		
Violation of water quality standards or waste discharge requirements or degrade water quality	LTSM	<ul style="list-style-type: none"> <li>Excavation, grading, and construction activities associated with construction of the Proposed Project could result in water quality violations from soil disturbance and potential sedimentation and erosion. It could also cause water quality violations in the event of an accidental fuel or hazardous materials leak or spill. The Construction General Permit requires the preparation and implementation of a formal SWPPP which must be prepared before construction begins. The SWPPP includes specifications for BMPs implemented during construction to control sedimentation or pollution concentration in stormwater runoff.</li> </ul>
Substantial depletion of groundwater supplies or interference with groundwater recharge	LTSM	
Substantial alteration of the existing drainage pattern of the site or area	LTSM	<ul style="list-style-type: none"> <li>The Proposed Project would be designed and operated in accordance with the applicable requirements of California Code of Regulations (CCR) Title 22 and any other local legislation that is currently effective or may become effective as it pertains to recycled water.</li> </ul>
Creation of contribution of runoff water which would exceed the capacity of existing or planned stormwater drainage systems or provide substantial additional sources of polluted runoff	LTS	<ul style="list-style-type: none"> <li>Salts and nutrients are a potential concern because recycled water could conceivably add measurable quantities of salts and/or nutrients and cause a drinking water quality objective to be exceeded if assimilative capacity did not otherwise exist. The Proposed Project site does not overly a regional aquifer or groundwater basin, but localized aquifers may be present. Runoff or subsurface flows could also run into the San Mateo Plain Subbasin, located to the east of the project. Adherence of the Proposed Project to all appropriate Title 22 requirements would ensure that potential impacts to public health or groundwater quality would be less than significant. Thus, No mitigation measures are required.</li> </ul>
Substantially degrade water quality	LTSM	
Placement of housing within a 100-year flood hazard area, or structures within a 100-year flood hazard area which would impede or redirect flood flows	NI	<ul style="list-style-type: none"> <li>The Proposed Project does not include groundwater pumping or recharge, and would have no impact to aquifer volumes or groundwater table levels.</li> </ul>
Exposure of people or structures to a significant risk or loss, injury or death involving flooding.	NI	<ul style="list-style-type: none"> <li>The Proposed Project would not alter the course of a stream or river.</li> </ul>
Inundation by seiche, tsunami or mudflow	NI	<ul style="list-style-type: none"> <li>The Proposed Project could temporarily alter the drainage of the Study Area during construction and excavation activities, which could result in additional sedimentation and erosion if mitigation measures are not incorporated to reduce these potential impacts. Additionally, installation of facilities at the treatment facility site could create additional runoff, sedimentation, and erosion during operation due to the grading needed at the site and the increased impermeable surface area. Installation of appropriate drainage (stormwater) facilities and erosion control at the site may be necessary to accommodate additional stormwater flows and reduce the potential for localized siltation/erosion and</li> </ul>

Environmental Topics	Expected Impact	Discussion of Major, Potential Environmental Effects
		<p>flooding, respectively. The inclusion of design elements to address runoff would ensure that impacts during operation of the Proposed Project would be less than significant.</p> <ul style="list-style-type: none"> <li>• The Proposed Project would not construct housing; therefore it would have no impact related to placing housing within a 100-year flood zone.</li> <li>• The Proposed Project is not located in and would not cross any flood zones.</li> <li>• The Proposed Project would not expose people to risks of flooding, dam, or levee failure. The treatment facility is the only component of the Proposed Project that would require staffing long-term, and is not located in a flood zone or downstream of an existing dam or levee.</li> <li>• There are no large enclosed water bodies in the project area that would be subject to seiche. Coastal low-lying areas in the City of Menlo Park may be affected by tsunamis, but the project area is over five miles away from the coast and at an elevation of over 200 feet above sea level. The impacts from seiche, tsunamis, and mudflows are expected to be less than significant.</li> </ul>
<b>Land Use and Planning</b>		
Physically divide an established community	NI	<ul style="list-style-type: none"> <li>• The Proposed Project is located within roadway ROWs and within the property line of the Sharon Heights Golf Course. As the treatment facility site is landlocked by other land uses and is under private ownership, development on this land would not divide the existing community.</li> </ul>
Conflict with any applicable land use plan, policy or regulation of an agency with jurisdiction over the Project adopted for the purpose of avoiding or mitigating an environmental effect	LTSM	<ul style="list-style-type: none"> <li>• The Proposed Project would be constructed in Open Space (for the treatment facility) and roadway ROWs (pipelines). Utility Substations can be located in Open Space with approval of a Use Permit. Acquisition of the permit and compliance with its conditions would ensure that the Project would not conflict with any application land use plan, policy or regulation and impacts would be less than significant.</li> </ul>
Conflict with any applicable HCP or NCCP	NI	
<b>Mineral Resources</b>		
Loss of availability of a known mineral source	NI	<ul style="list-style-type: none"> <li>• There are no active mining or mineral resource extraction occurring within the Study Area.</li> </ul>
<b>Noise</b>		
Exposure of persons to or generation of noise levels in excess of standards or excessive groundbourne vibration	LTSM	<ul style="list-style-type: none"> <li>• Construction of the Proposed Project would involve the use of heavy equipment that could create noise substantially above existing ambient noise levels. It also has the potential to generate noise in excess of relevant local noise regulations. Mitigation measures, such as limiting vibration to under appropriate thresholds for structures and people, would be needed to reduce potential construction-related impacts to less than significant.</li> </ul>
Substantial permanent or periodic increase in ambient noise levels in the project vicinity	LTSM	

Environmental Topics	Expected Impact	Discussion of Major, Potential Environmental Effects
<b>Exposure of persons residing or working within the vicinity of a private airstrip or public use airport to excessive noise levels</b>	NI	<ul style="list-style-type: none"> <li>Once constructed, the influent and disposal pipelines would not produce any excess noise.</li> <li>The treatment facility would produce permanent noise, primarily from the pump station and the additional truck trips required for delivery of materials necessary for operation. The noise-generating components of the treatment facility would be enclosed in buildings, which would dampen the noise. Furthermore, the treatment facility would also be located near an existing freeway, which would drown out much of the noise created by the treatment facility.</li> <li>There are no airports or airstrips within the vicinity of the Proposed Project.</li> </ul>
<b>Population and Housing</b>		
Induction of substantial population growth in an area either directly or indirectly	LTS	<ul style="list-style-type: none"> <li>The Proposed Project would not directly induce population growth because it would not produce additional water supply, but instead replaces imported supply (purchased water) with a more desirable (locally-produced) water.</li> </ul>
Displacement of substantial numbers of existing people or housing	NI	<ul style="list-style-type: none"> <li>The Proposed Project would not displace existing housing or people</li> </ul>
<b>Public Services</b>		
Substantial adverse physical impacts to public services including but not limited to fire and police protection, schools and parks	NI	<ul style="list-style-type: none"> <li>The Proposed Project would involve the production and delivery of recycled water to meet existing demand, and disposal of wastewater produced by the treatment process. It would not increase the use of or demand for public services (e.g., schools, parks, police, fire, or other public facilities).</li> </ul>
<b>Recreation</b>		
Substantial physical deterioration of park facilities	NI	
Include recreational facilities or require the construction or expansion of recreational facilities which might have an adverse physical effect on the environment	NI	<ul style="list-style-type: none"> <li>The Proposed Project would create recycled water to offset potable water use on an existing golf course, but not cause an increase in the use of existing parks or other recreational facilities.</li> </ul>

Environmental Topics	Expected Impact	Discussion of Major, Potential Environmental Effects
<b>Transportation/Traffic</b>		
Conflict with an applicable plan, ordinance or policy establishing measures of effectiveness for the performance of the circulation system	LTSM	<ul style="list-style-type: none"> <li>The Proposed Project would be constructed within roadway ROWs and within the Sharon Heights Golf Course property. For the waste disposal pipeline, open trench construction would be employed except at sensitive crossings, if any, where trenchless methods would be used. The assumed 30-foot construction footprint may require closure of some traffic lanes, thus reducing roadway capacities.</li> </ul>
Conflict with applicable congestion management program	LTSM	<ul style="list-style-type: none"> <li>Construction traffic could result in increased traffic volumes. Mitigation measures, such as development and implementation of a Traffic Control Plan, would be required to reduce traffic-related impacts of potential temporary lane closures during construction of the influent and disposal pipelines. There may be traffic impacts related to increased truck traffic during construction of the treatment facility, but no road closures are anticipated for this component of the Proposed Project.</li> </ul>
Changes in air traffic patterns, resulting in substantial safety risks	NI	
Substantially increase hazards due to a design feature (e.g. sharp curves or dangerous intersections) or incompatible uses	LTS	<ul style="list-style-type: none"> <li>The Proposed Project would not affect air traffic patterns, and would be located sufficiently far from an airport or airstrip to avoid creating a substantial air traffic safety risk.</li> </ul>
Inadequate emergency access or parking capacity	LTSM	<ul style="list-style-type: none"> <li>The Proposed Project would not create or substantially increase a traffic hazard due to a design feature. The roadway ROWs excavated for pipelines may be temporary reconfigured to accommodate construction activities, but would be restored to preconstruction conditions upon project completion.</li> </ul>
Conflict with adopted policies, plans, or programs regarding public transit, bicycle, or pedestrian facilities, or otherwise decrease the performance or safety of such facilities	LTSM	<ul style="list-style-type: none"> <li>Lane closures and other potential traffic impacts caused by construction activities associated with the Proposed Project would have potential to impede emergency response to those areas, or to areas accessed via those routes. Mitigation Measures, such as the development and implementation of a Traffic Control Plan, would reduce these impediments to less than significant.</li> <li>Upon completion, the Proposed Project would not conflict with adopted policies, plans, or programs regarding alternate transportation, nor would it decrease the safety of these facilities. Mitigation measures, such as development and implementation of a Traffic Control Plan, would reduce potential impacts to less than significant.</li> </ul>
<b>Utilities and Service Systems</b>		
Exceedence of wastewater requirements of the applicable Regional Water Quality Control Board	LTSM	<ul style="list-style-type: none"> <li>The Proposed Project would not increase the concentration of wastewater produced in the Study Area, but decrease the quantity of wastewater produced. It would convey waste produced at the treatment facility to the WBSD system for disposal. Based on the project size and relative contribution to the collection system, it is not anticipated to require SVCW to amend its NPDES permit to accommodate the flow.</li> </ul>
Expansions of, or construction of new water, wastewater, or stormwater facilities cause significant environmental effects or physical	LTS	

Environmental Topics	Expected Impact	Discussion of Major, Potential Environmental Effects
deterioration of a public facility due to increased use as a result of the project		<ul style="list-style-type: none"> <li>The Proposed Project would not cause SVCW to exceed the wastewater treatment requirements of the RWQCB and the SVCW NPDES would not need to be amended prior to the Proposed Project.</li> </ul>
Sufficient water supplies or capacity to serve the project	NI	<ul style="list-style-type: none"> <li>The Project proposes the construction of a treatment facility and influent and disposal pipelines. It does not include expansion of existing facilities (beyond those evaluated in this document).</li> </ul>
Adequate wastewater treatment capacity to serve the project	NI	<ul style="list-style-type: none"> <li>The Proposed Project would require additional on-site drainage facilities at the treatment facility site. The Proposed Project would increase the amount of impervious surface at the site, increasing total stormwater runoff to some degree. Mitigation measures to reduce potential effects could include improvements to the existing stormwater system, as needed.</li> </ul>
Have sufficient capacity at a landfill to accommodate the project's solid waste disposal needs and compliance with statutes and regulations related to solid waste	LTSM	<ul style="list-style-type: none"> <li>The Proposed Project would require additional on-site drainage facilities at the treatment facility site. The Proposed Project would increase the amount of impervious surface at the site, increasing total stormwater runoff to some degree. Mitigation measures to reduce potential effects could include improvements to the existing stormwater system, as needed.</li> </ul>
Comply with federal, state and local statutes and regulations related to solid waste	NI	<ul style="list-style-type: none"> <li>The Proposed Project would augment the District's capacity to serve the region's demand.</li> <li>The main contributor to solid waste (soil) generated by the Proposed Project would be the excavation and disposal of soil from the treatment facility site. Solid waste (soil) generated by the Proposed Project would likely be hauled to ???. Mitigation measures, such as maximizing reuse of excavated soil to the extent possible, including use as backfill for the pipelines, or identifying an alternate disposal site and/or construction timing should the identified landfill not be able to accommodate all of the waste, would reduce this potential impact to less than significant. Solid waste would be disposed of in accordance with all applicable federal, state, and local statutes and regulations.</li> </ul>
<b>Mandatory Findings of Significance</b>		
Substantial environmental degradation (e.g., reduction of sensitive habitat, endangered plant or animal species, or cultural resources,	LTSM	<ul style="list-style-type: none"> <li>Mitigation measures are anticipated to reduce potential biological and cultural impacts to less than significant.</li> <li>Most of the potential impacts from the Proposed Project would occur during construction. While all potential impacts of the Proposed Project could be mitigated to less than significant, there is potential for cumulatively considerable impacts in combination with other past, present, and probable future projects. This is most likely to occur in relation to air quality emissions, and the potential to contribute to global climate change. Further analysis of the potential cumulatively considerable impacts would be required to determine if additional mitigation measures would be necessary to reduce these potential impacts to less than significant.</li> </ul>
Contribution to cumulative impacts	LTSM	
Substantial adverse effects on human beings.	LTSM	<ul style="list-style-type: none"> <li>The potential impacts with the greatest potential adverse effects on humans and human health include air quality and traffic and transportation. Mitigation measures that address potential impacts would reduce impacts to humans to less than significant.</li> </ul>

Note: PS = Potentially significant; LTSM = Less than Significant with Mitigation Incorporation; LTS = Less than Significant; NI = No Impact.

## **Appendix E - WBSD and Sharon Heights MOU**

---

MEMORANDUM OF UNDERSTANDING  
ESTABLISHING PRINCIPLES OF AGREEMENT FOR DESIGN,  
CONSTRUCTION AND OPERATION OF RECYCLED WATER TREATMENT FACILITY

This Memorandum of Understanding is made this 20 day of April, 2015, by and between the West Bay Sanitary District ("West Bay") and the Sharon Heights Golf & Country Club ("Club") and provides as follows:

RECITAL

WHEREAS, West Bay is a Sanitary District organized and existing under the Sanitary District Act of 1924 (Cal. Health & Safety Code § 6400, et seq.), and provides wastewater collection and conveyance services to the Cities of Menlo Park, Atherton and Portola Valley, and portions of East Palo Alto, Woodside and unincorporated San Mateo and Santa Clara counties; and

WHEREAS, Club is a corporation duly organized and existing under the laws of the State of California that owns and operates a golf course and related facilities located within West Bay's service area at 2900 Sand Hill Road, Menlo Park, that is irrigated solely with potable water from the San Francisco Public Utilities Commission ("SFPUC") delivered by the Menlo Park Municipal Water District ("Menlo Park"), and its current use of water for irrigation purposes is approximately 200 AFY, with a peak daily demand during the summer irrigation season of approximately 0.400 mgd; and

WHEREAS numerous golf courses throughout California now use recycled water for irrigation purposes and such use has been shown to be beneficial and is consistent with State law and water policy; and

WHEREAS, the parties have preliminarily concluded that recycled water may be suitable for use as a substitute for the potable water currently used to irrigate the golf course, and are mutually interested in determining the feasibility of substituting recycled water for some or all of the potable water now used to irrigate the golf course; and

WHEREAS, on November 19, 2014, West Bay entered into that certain AGREEMENT FOR RECYCLED WATER FACILITIES PLAN BETWEEN WESTBAY SANTIARY DISTRICT AND RMC WATER AND ENVIRONMENT (the "RMC Study"), in an amount not to exceed \$150,000, up to fifty percent of the cost of which West Bay expects to be reimbursed by a grant from the California State Water Resources Control Board ("SWRCB"); and

WHEREAS, the Club has agreed to contribute toward the cost of the RMC Study in an amount equal to the amount paid by West Bay, not to exceed Thirty Seven Thousand Five Hundred Dollars (\$37,500) and to reimburse West Bay for the full cost incurred thereafter for the planning, design, environmental review, permitting, construction and operation of a recycled water treatment facility on Club property, ; and

WHEREAS, this Memorandum of Understanding is intended to establish the basic principles of a



long-term agreement (the "Agreement") to determine the feasibility of, design, construction and operation of a recycled water treatment facility on the Club's property.

#### TERMS

1. The parties agree that the principles of the California State Constitution and California Statutory Law and State Regulations (Water Code Sections 13550-13551 and Water Code Section 106) shall apply to their efforts to develop a recycled water treatment facility on property owned by Club using wastewater from West Bay as a substitute for all or a portion of the potable water currently and historically used for irrigating the golf course (the "Project").
2. The parties agree to negotiate in good faith and on a regular basis to resolve issues.
3. The Agreement shall provide for the following:
  - a. Cost of planning, design and construction of recycled water facilities as well as initial ownership of the facility during the designing/build phase;
  - b. A grant of easement in perpetuity from Club to West Bay for location of the recycled water treatment facility, subject to termination in event use of property for operation of a recycled water facility or sufficient delivery to the Club of treated water are permanently discontinued;
  - c. West Bay to have Ownership of treatment facility and all recycled water produced therefrom, subject to 1) Club's contractual right to receive recycled water in agreed upon quantity and quality, and 2) Club's recovery of a portion of any capital and operational costs invested in the Project from future users, pursuant to the contractual rights as stated in the Agreement ;
  - d. Club to own all water distribution facilities located on Club property outside of West Bay Easement Area;
  - e. Design criteria for recycled water facilities including:
    - i. Annual production capacity (afy)
    - ii. Daily production capacity (mgd)
    - iii. Building footprint
    - iv. Point of delivery
    - v. Method of delivery
    - vi. Water quality requirements
  - f. Responsibility for costs for design, permitting and construction and potential funding strategies

- g. Target date for completion
- h. Terms for operation and maintenance
  - i. Quantity and rate of delivery
  - ii. Minimum and maximum amount to be delivered
  - iii. Water quality requirements
- i. Club's use of recycled water exclusively on-site;
- j. West Bay's right to sell recycled water in excess of amount delivered to Club to third parties;
- k. Method for calculating recycled water service charge rates and adjusting rates
- l. Relationship and influence of Menlo Park Water District on the Agreement
- m. Additional terms
  - i. Liability/indemnification provisions
  - ii. Force majeure
  - iii. Dispute resolution
  - iv. Mediation
  - v. Arbitration/litigation
  - vi. Attorneys' fees and costs
  - vii. Remedies for non-performance
  - viii. Termination
  - ix. Miscellaneous
  - x. Conditions precedent
  - xi. Assignment
  - xii. Notice
  - xiii. Governing law/venue
  - xiv. Amendments
  - xv. Cessation during declared emergency
  - xvi. Relationship of parties
  - xvii. Severability
  - xviii. Waiver
  - xix. Counterparts
  - xx. Representations, warranties and covenants

- 4. Pending the final approval of the Agreement by West Bay and the Club, the Parties agree that Club shall reimburse West Bay for fifty percent of the cost incurred by

West Bay (less grant funded portion) for the RMC Study, upon completion of the study, and the full cost incurred by West Bay in connection with the environmental review, planning, design, permitting and construction of the Project, within thirty (30) days advance written notice by West Bay provided, however, that West Bay shall notify the Club and obtain approval prior to incurring such costs.

EXECUTED and effective on the date shown above by duly authorized representatives of the parties.

SHARON HEIGHTS GOLF COURSE AND COUNTRY CLUB

By:   
PAUL SCOTT  
President

WEST BAY SANITARY DISTRICT

By:   
PHIL SCOTT  
District Manager

APPROVED AS TO FORM:



Club Attorney

APPROVED AS TO FORM:

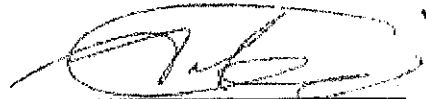

ANTHONY P. CONDOTTI  
District Counsel