

SANITARY SEWER BACKWATER VALVE REQUIRED

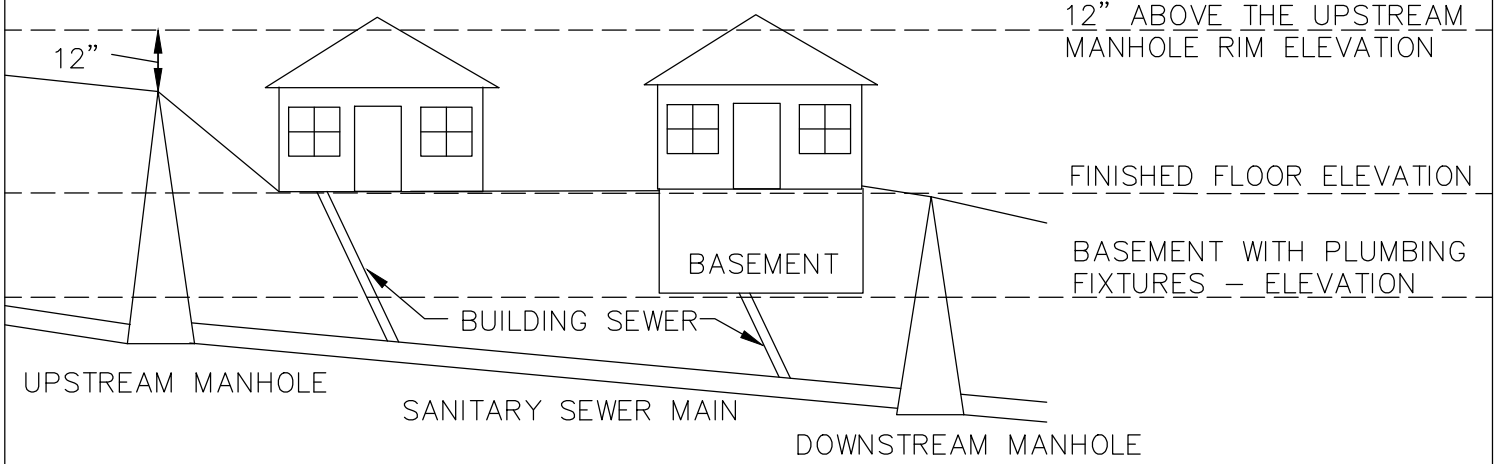

BASEMENT LOWER THAN UPSTREAM MANHOLE

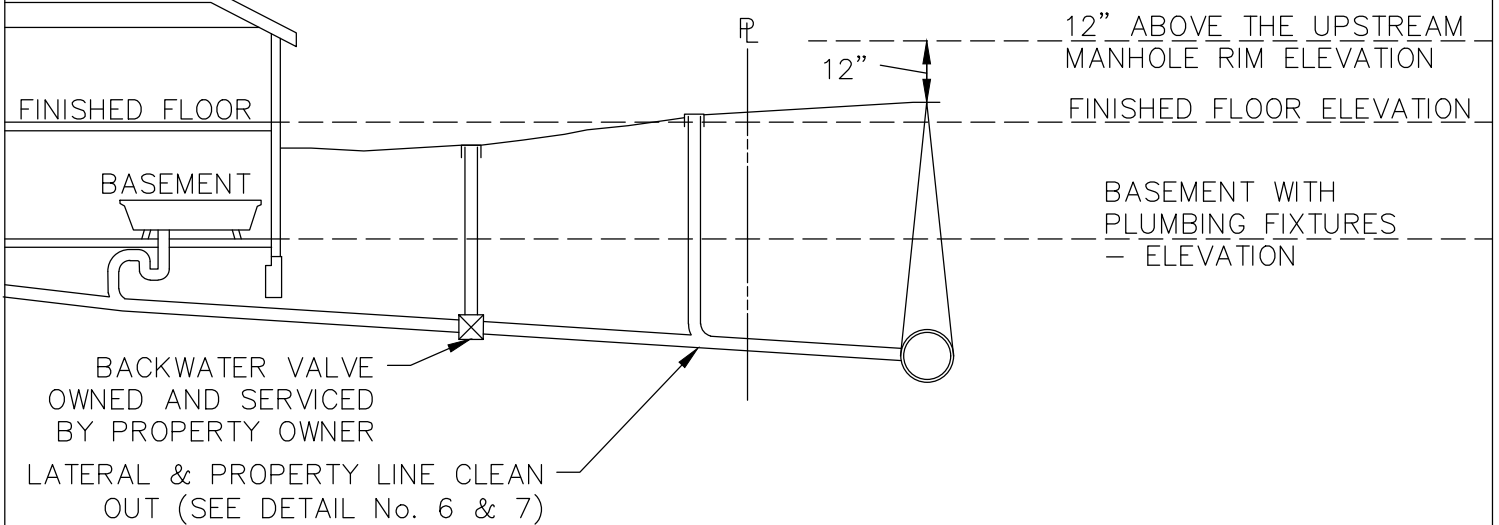

FINISH FLOOR LOWER THAN UPSTREAM MANHOLE

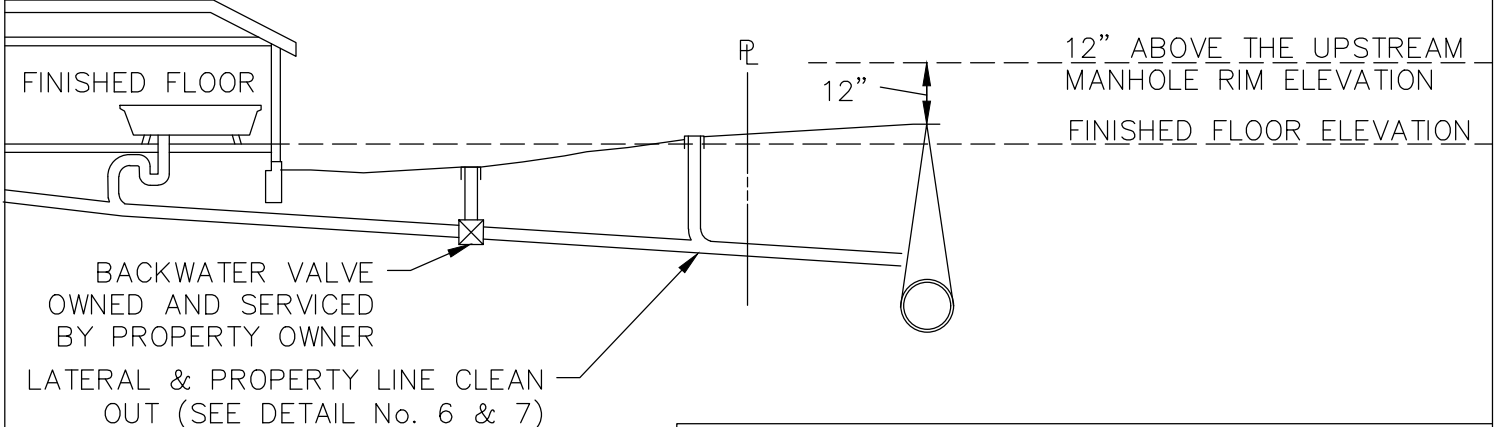

NOTES

1. ALL PLUMBING SHALL CONFORM TO UNIFORM PLUMBING CODE, LATEST EDITION.
2. BACKWATER VALVES SHALL BE INSTALL FOR ANY GRAVITY LATERAL THAT IS LESS THAN 12" ABOVE THE THE TOP OF THE NEAREST UPSTREAM STRUCTURE (MANHOLE).

WEST BAY
SANITARY DISTRICT

BACKWATER VALVE REQUIREMENTS

APPROVED BY:

/S/ - SERGIO RAMIREZ
GENERAL MANAGER

06-28-23
DATE:

13