

1902 - Serving Our Community for over 115 Years - 2020

**WEST BAY SANITARY DISTRICT
AGENDA OF BUSINESS**

REGULAR MEETING OF THE DISTRICT BOARD

WEDNESDAY, OCTOBER 28, 2020 AT 7:00 P.M.

**RONALD W. SHEPHERD ADMINISTRATION BUILDING,
500 LAUREL STREET, MENLO PARK, CALIFORNIA 94025**

Board Members

Fran Dehn, President
David Walker, Secretary
Roy Thiele-Sardiña, Treasurer
Edward P. Moritz, Member
George Otte, Member

District Manager

Sergio Ramirez

District Legal Counsel

Anthony Condotti, Esq.

AGENDA OF BUSINESS

NOTICE OF PUBLIC PARTICIPATION BY TELECONFERENCE ONLY

Pursuant to Governor Newsom's Executive Order N-29-20, members of the West Bay Sanitary District Board of Directors and Staff may participate in this meeting via a teleconference. In the interest of reducing the spread of COVID- 19, members of the public are allowed to participate **telephonically only**, and may submit comments in advance by email addressed to treese@westbaysanitary.org by 4:00 p.m. on Wednesday, October 28th.

To participate by telephone or Zoom meeting, public comments can be made by joining Zoom meeting at: <https://zoom.us/j/98627126561?pwd=NVRQNnFLaWxZOGovZTNTZ3IIMF11UT09>

Meeting ID: 986 2712 6561 Passcode: 940612

Or by phone, call: 1-669-900-6833 986 2712 6561 Passcode: 940612

Following receipt of public comment and open session items, the Board will adjourn to closed session. Reportable action, if any, will be available upon inquiry within twenty-four (24) hours.

NOTE: The Board may take action on any agendized item unless specifically designated a "discussion" item or a "report."

1. Call to Order and Roll Call
2. Communications from the Public
3. Public Hearing - Annexing Certain Territory Within the West Bay Sanitary District's On-Site Wastewater Disposal Zone – Lands of Yan (17 Redberry Ridge, Portola Valley) Pg. 3-1
4. Consideration of Adopting Resolution Ordering Annexation of Certain Parcels in the Territory of West Bay Sanitary District to the West Bay Sanitary District's On-Site Wastewater Disposal Zone Including Certain Determinations, Findings and Declarations of the District Board – Lands of Yan (17 Redberry Ridge, Portola Valley) Pg. 4-1
5. Consideration to Accept the Performance Merit Pay Program Results Oct. 1, 2019 to Sept. 30, 2020 and Authorize the District Manager to Disburse the Final Payout Pg. 5-1

6. District Manager's Report Pg.6-1
7. Consent Calendar

Matters listed under this item are considered routine and will be enacted by one motion. The motion, seconds, and vote are applicable to any included resolutions and recorded accordingly. There will be no separate discussion of these items unless specifically requested by a member of the Board.

 - A. Approval of Minutes for Regular meeting October 14, 2020 Pg. 7A-1
 - B. Approval of the Financial Activity Report/Withdrawal Order Authorizing Payment of Certain Bills and Salaries and Consideration of Other Financial Matters for October 28, 2020 Pg. 7B-1
 - C. Consideration to Approve District's Investment Portfolio Reports Including Transactions of Assets Described Therein as of 9/30/20 Pg. 7C-1
 - D. Consider Resolution Authorizing the President and Secretary to Enter into Agreement Creating Covenants Running With the Land for 17 Redberry Ridge, Portola Valley Pg. 7D-1
8. October 28th Update Report on District Response to Corona Virus Pg. 8-1
9. Report and Discussion on Sharon Heights Recycled Water Plant Pg. 9-1
10. Discussion and Direction on Bayfront Recycled Water Project and Status Update Pg. 10-1
11. Report and Discussion on South Bayside Waste Management Authority (SBWMA) Pg. 11-1
12. Report and Discussion on Silicon Valley Clean Water (SVCW) Plant Pg. 12-1
13. Closed Session
 - A. CONFERENCE WITH LEGAL COUNSEL – EXISTING LITIGATION
(Cal. Govt. Code §54956.9(d))
Name of Case: *1740 Oak Avenue, LP v. West Bay Sanitary District, et al.* – SM CSC Case No. 18CIV02183
14. Comments or Reports from Members of the District Board and Consider Items to be Placed on Future Agenda
15. Adjournment

The West Bay Sanitary District does not discriminate against persons with disabilities. Upon request, the agenda and agenda packet can be provided in a format to accommodate special needs. If you require a copy of the agenda or related materials in an alternative format to accommodate a disability, or if you wish to attend this public meeting and will require special assistance or other special equipment, please call the District at (650) 321-0384 at least five days in advance and we will make every reasonable attempt to provide such an accommodation.



WEST BAY SANITARY DISTRICT AGENDA ITEM 3

To: *Board of Directors*

From: *Bill Kitajima, Projects & IT Manager
Jonathan Werness, Engineering Technician*

Subject: *Public Hearing - Annexing Certain Territory Within the West Bay Sanitary District's On-Site Wastewater Disposal Zone – Lands of Yan (17 Redberry Ridge, Portola Valley)*

Background

On September 9, 2020, the Board adopted a Resolution of intention to annex the parcel referenced above to the District's On-Site Wastewater Disposal Zone. The Public Hearing date was established as October 28, 2020.

Analysis

The District's **Master Resolution Governing Annexations of Territory to the West Bay Sanitary District On-Site Disposal Zone** states: "Pursuant to Section 6959 of the Health and Safety Code, the date of the Public Hearing shall be commenced no less than 45 days nor more than 60 days from the date of adoption of the Resolution of Intention, and the Public Hearing shall be completed no more than 90 days after the first day of the hearing."

In accordance with Section 6960, and 6960.1 of the same code, reviews and reports of findings are required of both the County Health Officer and Regional Water Quality Control Board. Additionally, Section 6960.3 of this code requires the review and approval by a local agency formation commission, which has adopted rules and regulations affecting the functions and services of special districts.

The San Mateo County Health Officer has responded by a letter of approval dated September 29, 2020 a copy of which is attached; the San Francisco Bay Regional Water Quality Control Board responded by a letter of approval dated September 29, 2020, a copy of which is attached; and the San Mateo Local Agency Formation Commission has approved per their Resolution No. 777 dated January 15, 2019, a copy of which is attached.

Fiscal Impact

Property owners have paid all annexation fees and the fiscal impact would be additional sewer service charge revenue to the District once the parcel is connected.

Recommendation

The Board is asked to close the Public Hearing following public comment.

Attachments: San Mateo County Health Officer Letter
San Francisco Bay Regional Water Quality Control Board Letter
San Mateo Local Agency Formation Approval Letter



September 29, 2020

APN 080-241-130

Bill Kitajima
West Bay Sanitary District
500 Laurel Street
Menlo Park, CA 94025

Dear Mr. Kitajima:

**SUBJECT: ANNEXATION, 17 REDBERRY RIDGE, PORTOLA VALLEY,
APN 080-241-130**

Thank you for the September 29, 2020, letter of *Intention to Annex Certain Territory* to District's On-Site Wastewater Disposal Zone for the subject parcel. County Environmental Health has reviewed the letter of intent and has no objection to the annexation of this parcel into the District's on-site wastewater disposal zone.

Should you have any questions, please call me at (650) 372-6279.

Sincerely,

Gregory J. Smith, PG, REHS
Supervisor Water Protection and Land Use Programs

cc: Laura Russell, Planning Director, Town of Portola Valley





San Francisco Bay Regional Water Quality Control Board

September 29, 2020
File: CW-255833

Mr. Bill Kitajima (bkitajima@westbaysanitary.org)
Projects & IT Manager
West Bay Sanitary District
500 Laurel Street
Menlo Park, California 94025-3486

Approval to Annex Certain Territory (Lands of Yan) to the West Bay Sanitary District On-Site Wastewater Disposal Zone: APN: 080-241-130

Dear Mr. Kitajima:

The Regional Water Board hereby approves the annexation of the subject parcel to the On-Site Wastewater Disposal Zone of the West Bay Sanitary District (District). The property owners applied to the District for annexation “for the purpose of obtaining sewer service for a single-family residence.” To connect to existing District sewer facilities, the property owners require a Grinder Pump System that the District must maintain. Therefore, this parcel must be annexed into the District's disposal zone.

The Regional Water Board's approval is conditional upon the District (1) retaining responsibility for operation and maintenance of the grinder pump system, and (2) ensuring the proper operation and maintenance of the other sewerage facilities serving the parcel. Disposal of sewage onto soils within the disposal zone is not approved.

If you have any questions, please contact me at (510) 622-2407, or via e-mail at gaurav.mittal@waterboards.ca.gov.

Sincerely,

Gaurav Mittal
Water Resource Control Engineer



LOCAL AGENCY FORMATION COMMISSION

455 COUNTY CENTER, 2ND FLOOR • REDWOOD CITY, CA 94063-1663 • PHONE (650) 363-4224 • FAX (650) 363-4849

August 24, 2020

Sergio Ramirez
General Manager
West Bay Sanitary District
500 Laurel Street
Menlo Park, CA 94025

Re: LAFCo File No. 20-06 - Proposed annexation of 17 Redberry Ridge, Portola Valley, to On-site Wastewater Disposal Zone (OWDZ) of the West Bay Sanitary District

Dear Mr. Ramirez:

At a public meeting on August 19, 2020, the San Mateo Local Agency Formation Commission considered and approved the above-noted application and directed me to transmit written approval to the West Bay Sanitary District to annex the proposed single-family residence at 17 Redberry Ridge, Portola Valley to the District’s On-site Wastewater Disposal Zone. As the annexation does not necessitate a filing with the Board of Equalization, this approval letter concludes the LAFCo process for this application. Please feel free to contact me should you have any questions.

Sincerely,

Martha Poyatos
Executive Officer

cc: Jonathan Werness, WBSD
David Yan, Property Owner
Nina Davies, Applicant

COMMISSIONERS: JOSHUA COSGROVE, CHAIR, SPECIAL DISTRICT ▪ WARREN SLOCUM, VICE CHAIR, COUNTY ▪ RICH GARBARINO, CITY ▪ DON HORSLEY, COUNTY ▪ MIKE O’NEILL, CITY ▪ RIC LOHMAN, SPECIAL DISTRICT ▪ ANN DRAPER, PUBLIC

ALTERNATES: KATI MARTIN, SPECIAL DISTRICT ▪ HARVEY RARBACK, CITY ▪ JAMES O’NEILL, PUBLIC ▪ DAVE PINE, COUNTY

MARTHA POYATOS, EXECUTIVE OFFICER ▪ REBECCA ARCHER, LEGAL COUNSEL ▪ ROB BARTOLI, MANAGEMENT

STAFF: ANALYST ▪ ANGELA MONTES, CLERK

THIS PAGE LEFT INTENTIONALLY BLANK



WEST BAY SANITARY DISTRICT AGENDA ITEM 4

To: *Board of Directors*

From: *Bill Kitajima, Projects & IT Manager
Jonathan Werness, Engineering Technician*

Subject: *Consideration of Adopting Resolution Ordering Annexation of Certain Parcels in the Territory of West Bay Sanitary District to the West Bay Sanitary District's On-Site Wastewater Disposal Zone Including Certain Determinations, Findings and Declarations of the District Board – Lands of Yan (17 Redberry Ridge, Portola Valley)*

Background

This property will utilize a Septic Tank Effluent Pumping (STEP) system; consequently this property must be annexed into the District's On-Site Wastewater Disposal Zone. The proponent shall be required to connect to the existing force main along Redberry Ridge.

Analysis

Following the Public Hearing to annex certain territory to the District's On-Site Wastewater Disposal Zone, the attached resolution would formally complete the annexation of the referenced Lands of Yan.

Fiscal Impact

Property owners have paid all annexation fees and the fiscal impact would be additional sewer service charge revenue to the District once the parcel is connected.

Recommendation

Subject to the final review by legal counsel and the findings of the resolution holding true through the public hearing (i.e., protests by less than 35 percent of the voters and landholders), it is recommended by the Projects & IT Manager that the Board adopt the resolution as drafted.

Attachment: Resolution _____ (2020), Map, Legal/Geographic Description

WEST BAY SANITARY DISTRICT

RESOLUTION NO. _____ (2020)

RESOLUTION ORDERING ANNEXATION OF CERTAIN TERRITORY OF WEST BAY SANITARY DISTRICT TO THE WEST BAY SANITARY DISTRICT ON-SITE WASTEWATER DISPOSAL ZONE INCLUDING CERTAIN DETERMINATIONS, FINDINGS AND DECLARATIONS OF THE DISTRICT BOARD (LANDS OF YAN)

The District Board of West Bay Sanitary District determines, finds and declares as follows:

(a) The proceedings, which are the subject of the Resolution, are undertaken pursuant to Chapter 3 of Part 2 of Division 5 (commencing with Section 6950) of the California Health & Safety ("H & S") Code having to do with the formation of, and annexations to, on-site wastewater disposal zones.

(b) On September 9, 2020 the District Board approved and adopted Resolution No. 2228 (2020), "RESOLUTION OF INTENTION TO ANNEX CERTAIN TERRITORY TO THE WEST BAY SANITARY DISTRICT ON-SITE WASTEWATER DISPOSAL ZONE." Among other things, Resolution No. 2228 (2020) described the area to be annexed to the zone, the name and address of the applicant and the number, type, volume and location of on-site wastewater disposal systems proposed.

(c) Pursuant to Resolution No. 2228 (2020), a public hearing was noticed in the manner required by H&S § 6958. The public hearing was commenced on October 28, 2020 and closed on October 28, 2020.

(d) Prior to the close of the hearing, the District Board received and considered reports from the following public officials and agencies as required by law:

- i. From the Public Health and Environmental Protection Division, Health Services Agency of the County of San Mateo, a letter dated September 29, 2020, constituting the report of the local health officer specifying the matters required by H & S § 6960.1.
- ii. From the California Regional Water Quality Control Board, San Francisco Bay Region, a letter dated September 29, 2020 constituting the report of the affected regional water quality control board with regard to the matters required by H & S § 6960.1 and approving the proposed plan for wastewater disposal by the affected regional water quality control board required by H & S § 6960.4.
- iii. From San Mateo Local Agency Formation Commission, a letter by which the commission approved annexation to the District and the District's On-Site Wastewater Disposal Zone.

(e) At all times during the public hearing, the District was prepared to hear and receive any oral or written protests, objections and evidence which might be offered. No oral or written protests, objections or evidence in opposition to the proposal were made, presented or filed at any time. Therefore, pursuant to H & S § 6963, it is determined that written protests filed and not withdrawn prior to the conclusion of the public hearing represented:

- i. Less than 35 percent of the number of voters who reside in the territory to be annexed to the zone; and
- ii. Less than 35 percent of the number of owners of real property in the territory to be annexed to the zone who also own not less than 35 percent of the assessed value of real property in the territory to be annexed to the zone.

(f) The number and types of on-site wastewater disposal systems proposed to be acquired, operated, maintained and monitored in the territory to be annexed to the zone are in conformity with and do not exceed the limitations set forth in the reports referred to (d) i. and ii. above.

(g) The territory proposed for annexation to the zone contains two (2) voters as defined in the Elections Code.

(h) Operation of the zone in the territory to be annexed will not result in land uses that are not consistent with general plans, zoning ordinances or other land use regulations of the Town of Portola Valley, the County of San Mateo or any other affected public agency.

In consideration of the foregoing determinations, findings and declarations,

IT IS RESOLVED by the District Board as follows:

1. The territory described in Exhibit "A" shall be annexed to the West Bay Sanitary District On-Site Wastewater Disposal Zone.
2. This annexation shall be accomplished without an election and confirmation of voters within the area to be annexed shall not be required on the question of such annexation.
3. The exterior boundaries of the annexation shall include the same territory described in Exhibit "A" to Resolution No. 2228 (2020), which Exhibit "A" is attached to this Resolution and incorporated herein by reference.
4. There shall be one on-site wastewater disposal system serving one residential user in the territory to be annexed to the zone, which system the District will either acquire, operate, maintain or monitor, as the case may be, all as set forth in Exhibit "B" to Resolution No. 2228 (2020), which Exhibit "B" is attached to this Resolution and incorporated herein by reference.
5. Operations of the portions of the zone annexed herein shall be financed by a system of fees and charges imposed upon persons who make use of the on-site wastewater disposal system in the territory annexed to the zone. The fees and charges will be structured to take into account the actual costs of operating and administering the zone and the maintenance, repair and replacement of wastewater facilities within the

territory annexed to the zone. The fees and charges will, to the extent applicable, include the cost of transporting zone-generated wastewaters to appropriate wastewater treatment facilities.

Passed and adopted by the District Board of West Bay Sanitary District at a regular meeting thereof held on the 28th day of October, 2020 by the following vote:

AYES:

NOES:

ABSTAIN:

ABSENT:

President of the District Board of the
West Bay Sanitary District, San
Mateo County, State of California

Attest:

Secretary of the District Board of the
West Bay Sanitary District, San Mateo
County, State of California

EXHIBIT "A"
LEGAL DESCRIPTION FOR PROPERTY
LANDS OF YAN
TOWN OF PORTOLA VALLEY,
SAN MATEO COUNTY, CALIFORNIA

PARCEL I

LOT 13 AS SHOWN ON THAT CERTAIN MAP ENTITLED "BLUE OAKS, TOWN OF PORTOLA VALLEY, SAN MATEO COUNTY, CALIFORNIA", FILED IN OFFICE OF THE COUNTY RECORDER, OF SAN MATEO COUNTY, STATE OF CALIFORNIA ON AUGUST 6, 1998, IN VOLUME 128 OF MAPS, AT PAGES 64 TO 92 INCLUSIVE.

PARCEL II

A NON-EXCLUSIVE EASEMENT FOR INGRESS, EGRESS AND UTILITIES WITHIN ALL OF THE PUBLIC ROADS AND DRIVES AS SHOWN ON THAT CERTAIN MAP ENTITLED "BLUE OAKS, TOWN OF PORTOLA VALLEY, SAN MATEO COUNTY, CALIFORNIA", FILED IN OFFICE OF THE COUNTY RECORDER, OF SAN MATEO COUNTY, STATE OF CALIFORNIA ON AUGUST 6, 1998, IN VOLUME 128 OF MAPS, AT PAGES 64 TO 92 INCLUSIVE.

SAID EASEMENT IS TO BE APPURTENANT TO AND FOR THE BENEFIT OF PARCEL I ABOVE.

THE ABOVE DESCRIPTION SHOWN ON EXHIBIT "B" AND BY REFERENCE MADE A PART HEREOF.

END OF DESCRIPTION

PREPARED BY OR UNDER
THE SUPERVISION OF:

MICHAEL J. WALTERS, PLS 5528

MARCH 27, 2020
DATE



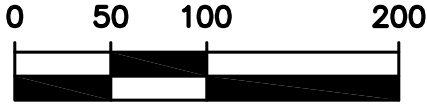

SCALE: 1" = 100'

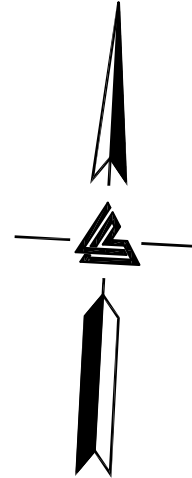
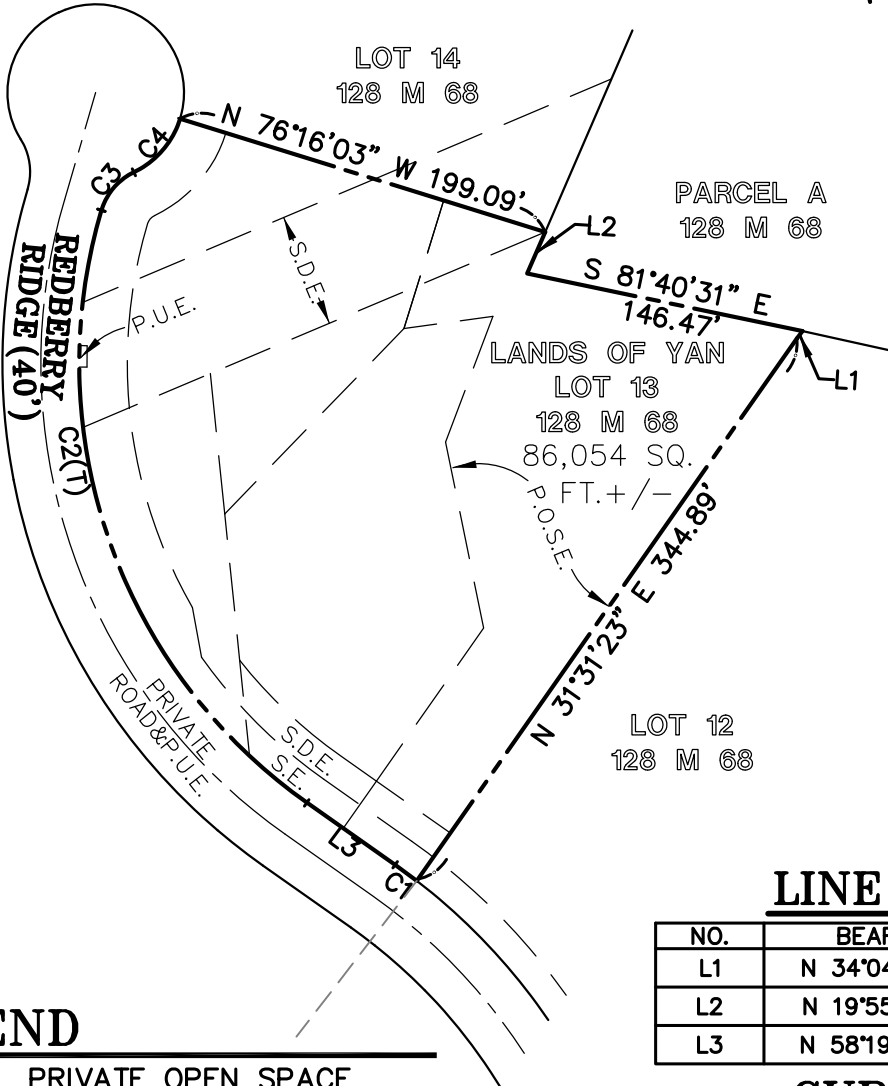

LINE TABLE

NO.	BEARING	DISTANCE
L1	N 34°04'03" E	4.81'
L2	N 19°55'23" E	23.53'
L3	N 58°19'49" W	56.06'

CURVE TABLE

NO.	DELTA	RADIUS	LENGTH
C1	02°30'23"	320.00'	14.00'
C2	71°21'37"	280.00'	348.73'
C3	48°00'33"	32.00'	26.81'
C4	47°10'37"	46.00'	37.88'

LEGEND

- P.O.S.E. PRIVATE OPEN SPACE EASEMENT
 - S.D.E. STORM DRAIN EASEMENT
 - P.U.E. PUBLIC UTILITY EASEMENT
 - S.E. SLOPE EASEMENT
-
- PROPERTY BOUNDARY
 - CENTERLINE
 - ADJACENT PROPERTY



LEA & BRAZE ENGINEERING, INC.

CIVIL ENGINEERS • LAND SURVEYORS
 BAY AREA REGION SACRAMENTO REGION
 2495 INDUSTRIAL PKWY WEST 3017 DOUGLAS BLVD, # 300
 HAYWARD, CALIFORNIA 94545 ROSEVILLE, CA 95661
 (P) (510) 887-4086 (P) (916)966-1338
 (F) (510) 887-3019 (F) (916)797-7363
 WWW.LEABRAZE.COM

EXHIBIT "B"
PLAT TO ACCOMPANY LEGAL
DESCRIPTION FOR LANDS OF YAN
17 REDBERRY RIDGE,
PORTOLA VALLEY, SAN MATEO COUNTY, CA.

WEST BAY SANITARY DISTRICT
EXHIBIT "B"
SITE LOCATION
17 REDBERRY RIDGE
PORTOLA VALLEY, CA
STEP SYSTEM



(1) STEP System
200 Gallons Per Day (GPD)
APN: 080-241-130
Lands of Yan
17 Redberry Ridge
Portola Valley, CA
Location of System: Front of the property

17 Redberry Ridge
STEP System Location

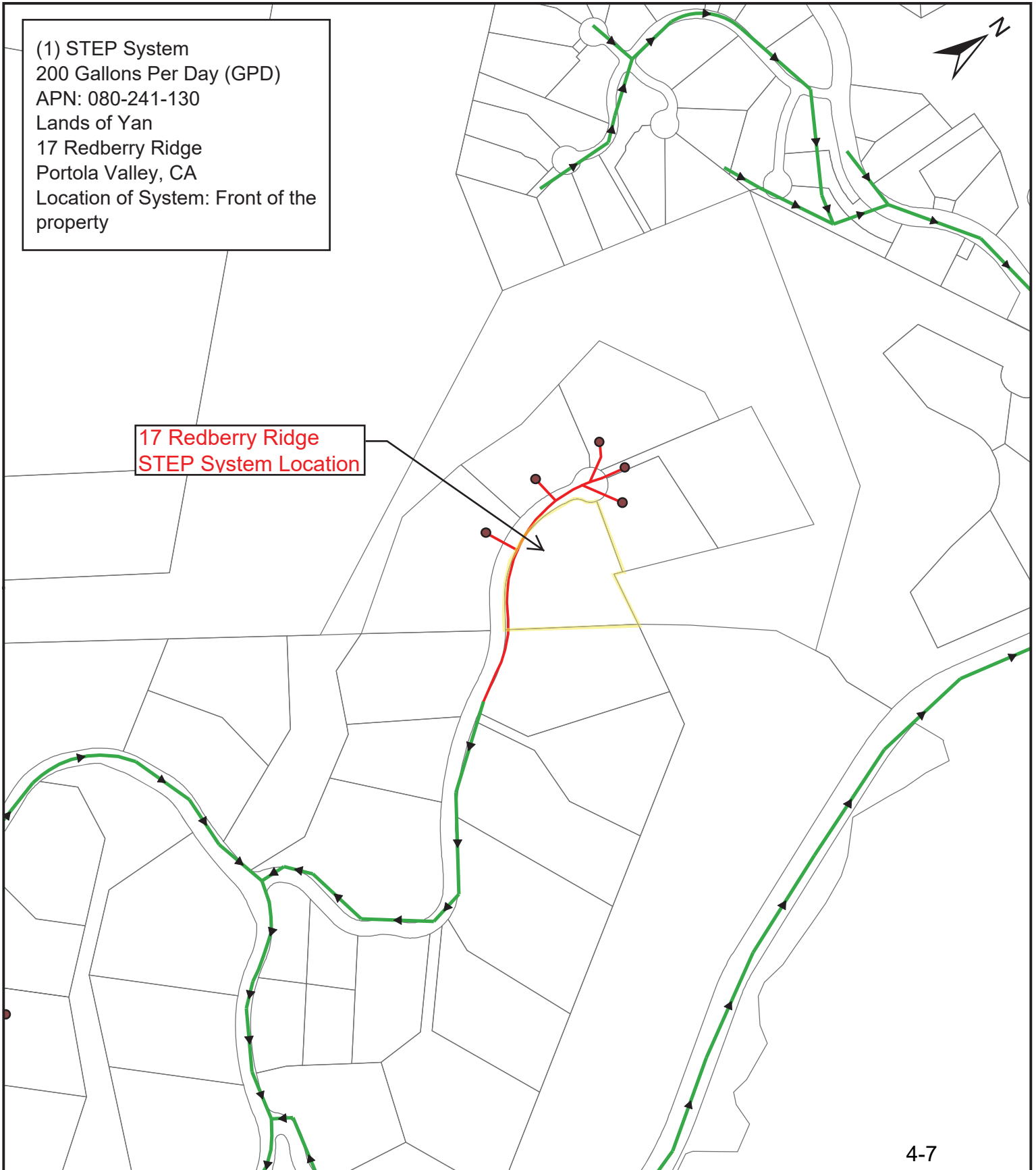

THIS PAGE LEFT INTENTIONALLY BLANK



WEST BAY SANITARY DISTRICT AGENDA ITEM 5

To: *Board of Directors*

From: *Bob Hulsmann, Operations Superintendent
Sergio Ramirez, District Manager*

Subject: *Consideration to Accept the Performance Merit Pay Program Results Oct. 1, 2019 to Sept. 30, 2020 and Authorize the District Manager to Disburse the Final Payout*

Background

In September of 2012 the Board approved implementation of the Performance Merit Pay Program (Program). The Program was introduced to Staff during negotiations and the MOU allowed for a Board approved program to be adopted. Staff immediately began working on the Program's aggressive goals in October of 2012.

The Board approved the criteria with the established goals based on recommendations from the District Manager in September 2019. The Board subsequently approved the budget for the Program in the FY2020/21 Budget.

The Board adopted Director Moritz's Program template using performance measures identified in the monthly Operations & Maintenance reports. Using this template, the District Manager and staff inserted figures for the expected base productivity level for each identified performance measure and the optimum target goal productivity level.

Analysis

The District approved the program for the 7th year of the program running from October 1, 2019 to September 30, 2020. The totals and weight factors of the overall performance have been completed (see attachment A).

The purpose of such a program is to award staff for meeting or exceeding performance goals. The goals are not for normal performance (base) but to recognize extraordinary performance. The intent of this program is to move productivity to a new level, sustain high productivity levels, and reward the efforts of District staff for their performance in improving the efficiency and quality of work and reducing Sanitary Sewer Overflows (SSOs).

During this year's Program the District experienced ZERO SSOs for the first time.

The "Miles of Pipe Cleaned" goal component was very aggressive as it required the crews to clean a minimum of 160 miles of pipe in order to meet the base of the goal and up to 170 miles of pipe cleaning in order to receive the full value of the goal. The crew completed 183.7 miles of pipe which accounts primarily for all of the District's smaller diameter pipe that has not been recently reconstructed or rehabilitated. Another measure in this component is efficient use of "man-hours" to clean the miles of pipe. The crew's efficiency this year resulted in the full payout of this component.

During the PMP year Staff also cleaned 10 miles of Large Diameter Pipe which is included in the 183.7 miles of pipe cleaned. This project was taken on by staff after receiving a \$1.2 million dollar bid to clean and CCTV the large diameter pipe. Staff felt that they could perform this task in house and save the District hundreds of thousands of dollars.

During the months of March, April and May management decided to shut down the day to day CCTVing and Pipe Rehab operations. These crews were reassigned to pipe cleaning to expand our efforts in keeping the sewage in the pipes. This was increasingly important due to the unknown effects of COVID-19 in sewage and the increased usage "flushable wipes". This extra effort was instrumental in the District's SSO count of Zero.

This is the first year staff has accomplished 100% of the goals, in spite of the COVID-19 challenges.

Fiscal Impact

The total budgeted amount for FY2020/2021 is \$150,000 (30 FTE's x \$5k) as maximum possible payout. The Performance Merit Pay Program payout per employee are according to the percent of goal achieved; multiplied by the weight of the performance measure which results in a value for the particular performance measure. The value of all ten performance measures is then added to determine the final annual payout per employee based on the number of workdays during October 1, 2019 and September 30, 2020. The attached payout calculation document indicates this year's payout is \$137,851.41 in total. The 100% payout equates to \$5,000.00 per full time employee (see attachment B).

Recommendation

The District Manager recommends the Board consider the above factors and approve the payout amounts based on the Performance Merit Pay Program Results and direct the District Manager to disburse payments in November 2020.

Attachment: Attachment A – Performance Merit Pay Program Results 2019-20

Attachment B – Payout Calculations

Attachment A

WEST BAY SANITARY DISTRICT

PERFORMANCE MERIT PAY PROGRAM (PMPP)

No.	Performance Element	Base	PMP Goal w/o manhours	Actual w/o manhours	% of Goal w/o manhours	Base	Target Goal	Actual	% of Goal	Weight	Value
1	Customer Satisfaction		---	---	---	90%	98%	99.02%	100.0%	0.08	0.08
2	Safety (Days of Work Lost/Yr)		---	---	---	3	0	0	100%	0.08	0.08
3	Miles Pipe CCTV'd / Manhour	40	50	42.3	85%	0.0082	0.0154	0.0236	100.0%	0.09	0.09
4	Miles Pipe Cleaned - Manhour	160	170	183.7	108%	0.0347	0.0366	0.0372	100.0%	0.15	0.15
5	Unscheduled Pump Station Repairs		---	---	---	18	12	5	100.0%	0.03	0.03
6	Pipe Repair Dig-Ups / Manhour	75	90	83	92%	0.0309	0.037	0.1531	100.0%	0.04	0.04
7	Pipe Repair Patches / Manhour	50	65	73	112%	0.0206	0.0267	0.1867	100.0%	0.04	0.04
8	SSO's (Category 1)	---	---	---	---	3	0	0	100%	0.2	0.2
9	SSO's (Category 2 & 3)	---	---	---	---	10	6	0	100%	0.22	0.22
10	Quality Control - Line Cleaning	---	---	---	---	8	0	0	100%	0.07	0.07
Total										100%	100%

Attachment B

Performance Merit Payout

Maximum Merit Payout: \$5,000 = \$20.08 per Work Day x 249 Working Days x Percentage of Goal Achieved (100%)

Percentage of Goal Achieved = 100%

	Full Time Employees	Work Days	Staff	Percentage	Payout per EE	Total Payout
1	\$20.0803/Wkday x 249 x 100%	249	25	100%	\$ 5,000.00	\$ 125,000.00
2	\$20.0803/Wkday x 234 x 100%	234	1	94%	4,698.80	4,698.80
3	\$20.0803/Wkday x 185 x 100%	185	1	74%	3,714.86	3,714.86
4	\$20.0803/Wkday x 129.13 x 100%	129	1	52%	2,592.87	2,592.87
5	\$20.0803/Wkday x 91.88 x 100%	92	1	37%	1,844.88	1,844.88
6	Not qualified	Less 90	4	0%	-	-
Total Payout			33			\$ 137,851.41



WEST BAY SANITARY DISTRICT AGENDA ITEM 6

To: *Board of Directors*

From: *Sergio Ramirez, District Manager*

Subject: *District Manager's Report*

1) Administrative:

- a. Speaking with LAFCo on taking the lead on a CEQA review for the Stonegate Annexation in Portola Valley. The Stonegate Annexation will annex approximately 9 parcels into the District. Currently the nine parcels are being served by septic tank.
- b. Staff is waiting to receive a Fujitsu scanner for the Pilot Scanning Project.

2) Finance:

- a. Finance Manager continues to work extensively to address SVCW's credit rating consultant inquiries.
- b. End of the 2019/2020 Fiscal Year audit is underway.

3) CIP & IT Projects:

a. Levee Improvement Project:

- i. F&L is continuing to work on the Environmental Impact Report and preparing Draft review in October. To date the EIR has cost \$467,449 of the Board approved \$644,745.

b. Construction Capital Improvement Projects (CIP)

- i. Working on Call for Bids for Bay North and Ringwood pipeline replacement.
- ii. Received Maintenance Building Feasibility Study update including 3 potential building layout options.

4) Operations and Maintenance:

a. Performance Merit Pay Program:

- i. Operations Superintendent to present the PMPP results at the October 28th Board meeting.
- ii. Lisandro Marquez has been named Pump Facility Supervisor.

b. Training:

- i. COVID 19 Staff Training scheduled for October.

Report to the District Board for the Regular Meeting of October 28, 2020

Additional information or topics may be introduced by the DM verbally during the Board meeting.

- 5) **Water Quality:**
 - a. **Sharon Heights Golf and Country Club:**
 - i. Operations going well. To date over 15 million gallons of recycled water has been delivered.
 - ii. Anderson Pacific O & M for the SHGCC recycled water plant is going well. All payments are invoiced and paid on time.
 - b. **Bayfront Recycled Water Plant (BRWP):**
 - i. Finalizing Environmental Impact Report (EIR) draft.
 - ii. Staff and Woodard and Curran has met with potential four Bayfront Recycled Water Facility partners, individually, in October.
- 6) **Fleet and Facilities:**
 - a. **Vehicle Maintenance:**
 - i. Staff is met with the City of Redwood City to plan vehicle maintenance services.
 - ii. Working on new Service Truck and should be completed by the end of December.
- 7) **Upcoming Events:**
 - a. **Ribbon Cutting for West Bay SHGCC Recycled Water Plant:** October 27,2020
 - b. **Next Regular Board meetings:** October 28, 2020
 - c. **Thanksgiving Lunch:** November 10, 2020
 - d. **Special Board Meeting:** November 18, 2020 (only one meeting in November)
- 8) **Misc./Action Items from Previous Meeting:**
 - a. **West Bay SSOs:** Zero SSOs for September 2020 (16 months in a row w/o SSO).
 - b. **LAH Contract:** Zero SSO for August. 2 SSO in 2020. Continuing to maintain the collection system and both Publicly Owned Pump Stations.
 - c. **Town of Woodside Contract:** Continuing to maintain High Frequency cleaning downtown and both Publicly Owned Pump Stations.
 - d. **Revenue:** Received approximately \$253,000 from September 16 to October 7, 2020 for permits issued, reimbursements, and services rendered to others.

Report to the District Board for the Regular Meeting of October 28, 2020

Additional information or topics may be introduced by the DM verbally during the Board meeting.



1902 - Serving Our Community for over 110 Years - 2020

**WEST BAY SANITARY DISTRICT
CHECKLIST OF THE REGULAR MEETING OF THE DISTRICT BOARD
WEDNESDAY, OCTOBER 14, 2020 AT 7:00 P.M.**

1. Call to Order

President Dehn called the meeting to order at 7:05 PM

Roll Call

BOARD MEMBERS PRESENT: President Dehn by Zoom, Secretary Walker, Treasurer Thiele-Sardiña, Director Moritz, Director Otte

BOARD MEMBERS ABSENT: None

STAFF MEMBERS PRESENT: Ramirez, Kitajima, Condotti by Zoom

Others Present by Zoom: Tim Steele, Sr. Vice President with Sobrato Group, Teresa Herrera and Matt Anderson with SVCW, Joe La Mariana with SBWMA

2. Communications from the Public: None.

3. Report by Silicon Valley Clean Water (SVCW) Staff

Comments: SVCW staff gave a presentation on the construction projects and finance plan in relation to WIFIA rate re-set, bond refunding and the application for a new SRF loan.

4. Authorize District Manager to Execute an Amended Financing Agreement in Connection with Water Infrastructure Finance and Innovation Act ("WIFIA") Loan by and Between Silicon Valley Clean Water and the U.S. Environmental Protection Agency

Motion to Approve by: Moritz 2nd by: Otte Vote: AYE: 5 NAY: 0 Abstain: 0

Comments: None.

5. Consideration to Approve Town of Atherton's Withdrawal from Membership in the South Bayside Waste Management Authority

Motion to Approve by: Mortiz 2nd by: Walker Vote: AYE: 5 NAY: 0 Abstain: 0

Comments: SBWMA Executive Director Joe La Mariana reported by Zoom, the process necessary to allow the Town of Atherton to exit the JPA. The Board supported Atherton's decision. All approvals must be done by member agencies by the end of December. President Dehn reported by Zoom that the SBWMA Board has agreed to the \$2.2M payment by the Town of Atherton to exit.

6. Report and Discussion on the City of East Palo Alto - Upcoming Projects

Comments: District Manager Ramirez gave a presentation of the City of East Palo Alto projects and the need for sewer collection to service the community of East Palo Alto. Director Otte suggested entertaining annexing so West Bay can provide some relief to the flows in other areas in the East Palo Alto Sanitary District. District Manager Ramirez reported 3 projects are contiguous while 2 are not. Tim Steele, Sr. Vice President with Sobrato Group reported a potential Bayshore road pipeline would be 1,000 feet long, and serve the University II Project. He reported on the difficulty they have had with the East Palo Alto Sanitary District. Assistant City Manager Patrick Heisinger reported 965 Weeks Street is a City of East Palo Alto owned project. President Dehn asked if the developers would pay for the studies needed. Mr. Steele stated they would pay for the necessary studies. District Manager Ramirez reported that EPA Waterfront also offered to pay for studies.

7. District Manager's Report

Comments:

1) Administrative:

- a. LAFCo is asking if West Bay will take the lead on a CEQA review for the Stonegate Annexation in Portola Valley. The Stonegate Annexation will annex approximately 9 parcels into the District. Currently the nine parcels are being served by septic tank.
- b. Staff will enter into a "Lease to Own" agreement to purchase a Fujitsu scanner for the Pilot Scanning Project. President Dehn stated that she was assurance that all fees would be recovered if the District takes the lead on CEQA for this project, including staff time, consultant fees and attorney fees.

2) Finance:

- a. Finance Manager continues to work extensively to address SVCW's credit rating consultant inquiries regarding the District's finances in preparation for the Plant's Debt Refinancing.
- b. End of the 2019/2020 Fiscal Year audit is underway.

3) CIP & IT Projects:

a. Levee Improvement Project:

- i. F&L is continuing to work on the Environmental Impact Report and preparing Draft review for early October. To date the EIR has cost \$467,449 of the Board approved \$644,745. The Board approved an additional \$341,198 for Levee Design and Levee Permitting of which \$32,290 has been used.

b. Construction Capital Improvement Projects (CIP)

- i. Design work for the Bay North and Ringwood pipeline replacement is completed. Next step is to approve the Call for Bids.
- ii. Contractor continues to work with Menlo Park on the Metal Storage Building permit.

4) Operations and Maintenance:

a. Performance Merit Pay Program:

- i. Maintenance staff has been working diligently on the cleaning and repair goals.
- ii. Operations Superintendent to present the PMPP results at the October 28th Board meeting.
- iii. Recruiting for Pump Facility Supervisor and a Maintenance Worker is going well.

b. Training:

- i. COVID 19 Updated Plan Staff Training scheduled for October

5) **Water Quality:**

a. **Sharon Heights Golf and Country Club:**

- i. Operations going well. To date over 14 million gallons of recycled water has been delivered.
- ii. Anderson Pacific has begun the 6 month O & M for the SHGCC recycled water plant. PG&E cost are coming in higher than anticipated because of PG&E electrical cost increases.

b. **Bayfront Recycled Water Plant (BRWP):**

- i. Working on Environmental Impact Report (EIR) draft.
- ii. Staff and Woodard and Curran will be meeting with potential Bayfront Recycled Water Facility partners in October.

6) **Fleet and Facilities:**

a. **Vehicle Maintenance:**

- i. Staff is meeting with the City of Redwood City to plan vehicle maintenance services.
- ii. Staff is purchasing additional spare hoses for the PipeHunter cleaning and CCTV inspection units approved in the budget.

7) **Upcoming Events:**

- a. **Ribbon Cutting for West Bay SHGCC Recycled Water Plant:** October 27,2020
- b. **Next Regular Board meetings:** October 28, 2020
- c. **Thanksgiving Lunch:** November 10, 2020
- d. **Special Board Meeting:** November 18, 2020 (only one meeting in November)

8) **Misc./Action Items from Previous Meeting:**

- a. **West Bay SSOs:** Zero SSOs for September 2020 (16 months in a row w/o SSO).
- b. **LAH Contract:** Zero SSO for August. 2 SSO in 2020. Continuing to maintain the collection system and both Publicly Owned Pump Stations.
- c. **Town of Woodside Contract:** Continuing to maintain High Frequency cleaning downtown and both Publicly Owned Pump Stations.
- d. **Revenue:** Received approximately \$253,000 from September 16 to October 7, 2020 for permits issued, reimbursements, and services rendered to others.

8. **Consent Calendar**

Motion to Approve by: Dehn 2nd by: Thiele-Sardiña Vote: AYE: 5 NAY: 0 Abstain: 0

CONSIDERATION OF ITEM(S) REMOVED FROM THE CONSENT CALENDAR

Comments: None.

- A. Approval of Minutes for Regular meeting September 23, 2020
- B. Approval of the Financial Activity Report/Withdrawal Order Authorizing Payment of Certain Bills and Salaries and Consideration of Other Financial Matters for October 14, 2020
- C. WBSD Operations and Maintenance Report – September 2020

- D. Town of Los Altos Hills Operations and Maintenance Report for Work Performed by WBSD – September 2020
- E. Town of Woodside Operations and Maintenance Report for Work Performed by WBSD – September 2020
- F. Consideration to Approve Class 3 Permit 20 Navajo Place, Portola Valley, CA

9. Consideration to Adopt Resolution Delineating Environmental Findings and Authorizing the District Manager to Call for Bids for the North Bay Road & Ringwood Avenue Project

Motion to Approve by: Moritz 2nd by: Dehn Vote: AYE: 5 NAY: 0 Abstain: 0

Comments: Projects and IT Manager Kitajima reported on the call for bids and the project's specifics. President Dehn asked for staff to find out if the County of San Mateo are planning to perform work in the project area.

10. October 14th Update Report on District Response to Corona Virus

Comments: Staff training on the updated COVID Response Program is planned for October.

11. Report and Discussion on Sharon Heights Recycled Water Plant

Comments: District Manager Ramirez reported on the current status of the treatment plant.

12. Discussion and Direction on Bayfront Recycled Water Project and Status Update

Comments: The Board had an extensive discussion on brining recycled water from Redwood City. The Board inquired if Redwood City recycled water costs were accurate and current. President Dehn asked District Manager Ramirez, when meeting with the developers, to ask them for accurate figures on water demand and to include toilet uses if possible.

13. Report and Discussion on South Bayside Waste Management Authority (SBWMA)

Comments: President Dehn reported that at the upcoming SBWMA Board/TAC study session on October 15 the new budget will be discussed.

14. Report and Discussion on Silicon Valley Clean Water (SVCW)

Comments: Director Otte reported that the next Commission meeting will be held on October 19.

15. Closed Session

Entered closed session at 8:52 p.m. Left closed session at 9:04 p.m.

Reportable action: None.

- A. CONFERENCE WITH LABOR NEGOTIATORS
Agency Designated Representative: District Manager
Unrepresented employees: Water Quality Manager

16. Comments or Reports from Members of the District Board and Consider Items to be Placed on Future Agenda

Comments: None.

17. Adjournment Time: The meeting was adjourned at 9:05 PM

Secretary

THIS PAGE LEFT INTENTIONALLY BLANK

WEST BAY SANITARY DISTRICT
Financial Activity Report
Withdrawals
October 8, 2020 through October 20, 2020

CHECK	DATE	TO WHOM PAYABLE	PURPOSE	AMOUNT
67061	10/13/2020	MATHESON TRI-GAS, INC.	Gas Monitors - 9/2020	52.28
67062	10/13/2020	ALMANAC ONLINE	Advertising: Lands of Yan	1,056.00
67063	10/13/2020	ANDERSON PACIFIC	6-Month Operational Period - RWF SH	63,768.71
67064	10/13/2020	AQUALITY WATER MANAGEMENT INC.	O&M Support	695.14
67065	10/13/2020	ATCHISON, BARISONE & CONDOTTI	Attorney Fees 9/2020	9,340.96
67066	10/13/2020	BAYSIDE EQUIPMENT COMPANY	Unit 210: Fuel Hose Replacement 9/2020	400.04
67067	10/13/2020	CALPERS LONG-TERM CARE PROGRAM	LTC Withholding 10/9/2020	35.36
67068	10/13/2020	CITY OF FOSTER CITY	Advertisements - Job Postings	1,020.00
67069	10/13/2020	URBANOWICZ, JOHN H.	Return 1yr Construction Deposit; CR 460782, 8/12/19	8,000.00
67070	10/13/2020	DEWEY PEST CONTROL	Contract Services - Rodent Control	8,457.00
67071	10/13/2020	LASKY TRADE PRINTING	Business Cards - 9/2020	142.03
67072	10/13/2020	GRAINGER	Operating Supplies, including PPE 9/2020	2,078.37
67073	10/13/2020	HACH COMPANY	Hach Logger	3,010.00
67074	10/13/2020	HOME DEPOT CREDIT SERVICES	Tools, Wood, & Misc Supplies 9/2020	237.55
67075	10/13/2020	IEDA	Consulting Services 10/2020	786.00
67076	10/13/2020	INTERSTATE TRAFFIC CONTROL	Safety Vest & Street Signs 10/2020	55.99
67077	10/13/2020	JANI-KING OF CA, INC - SFR/OAK	Custodial Service 10/2020	743.31
67078	10/13/2020	KONE PASADENA	Elevator Maintenance 10/2020	267.12
67079	10/13/2020	ERIC MADRIGAL	Misc. Expense - District Anniversary	75.00
67080	10/13/2020	CITY OF MENLO PARK - Water	Water Service - 9/2020	85.47
67081	10/13/2020	CITY OF MENLO PARK-Fuel	Fuel 9/2020	4,779.10
67082	10/13/2020	OGASAWARA LANDSCAPE MAINT.	Building Maintenance 9/2020	400.00
67083	10/13/2020	OMEGA INDUSTRIAL SUPPLY, INC.	Cleaning Solutions, Hand Sanitizer & Wipes 9/2020	2,328.31
67084	10/13/2020	PACIFIC GAS & ELECTRIC	Gas & Electric Service - 9/2020	1,066.61
67085	10/13/2020	PENINSULA BUILDING SUPPLY	Shovels 9/2020	116.88
67086	10/13/2020	RED WING BUSINESS	Safety Shoes - 9/2020	187.64
67087	10/13/2020	ROBERTS & BRUNE COMPANY	Couplers 9/2020	411.17
67088	10/13/2020	SHARP ELECTRONICS CORPORATION	Copier Machine 9/2020	288.59
67089	10/13/2020	SPARTAN TOOL, LLC	Power Cords 9/2020	412.22
67090	10/13/2020	3T EQUIPMENT COMPANY	Operating Supplies 9/2020	295.73
67091	10/13/2020	TOWNE FORD SALES	Unit 209: Vehicle Maint. & Unit 226: Repairs 9/2020	1,754.91
67092	10/13/2020	VISION COMMUNICATIONS CO.	Radio Service & Radio Repairs 10/2020	1,274.10
67093	10/20/2020	READYREFRESH BY NESTLE	Water Bottles 9/2020	62.28
67094	10/20/2020	CALIFORNIA WATER SERVICE	Water Service 9/2020	2,171.84
67095	10/20/2020	CINTAS CORP.	Uniform Cleaning 9/2020	4,014.28
67096	10/20/2020	DU-ALL SAFETY, LLC	Monthly Contract 9/2020	1,620.00
67097	10/20/2020	EAST BAY MUNI UTILITY DISTRICT	BACWA Membership & Program Fees FY 2020-21	2,458.50
67098	10/20/2020	NAVIA BENEFIT SOLUTIONS	Flexible Spending Account PR Contributions	525.39
67099	10/20/2020	FRANCHISE TAX BOARD	Earnings Withholding Order #557391483	250.00
67100	10/20/2020	FREYER & LAURETA	Bayfront, North Bay Road & Ringwood CIP Designs 9/2020	16,890.78
67101	10/20/2020	GRAINGER	Cables, Ropes 9/2020	1,127.13
67102	10/20/2020	PENINSULA BATTERY INC.	Replacement Battery for the Roller Trailer & Concrete Saw and Joh	333.61
67103	10/20/2020	PONTON INDUSTRIES, INC.	Long Life Batteries, 100 AH 8/2020	1,678.75
67104	10/20/2020	WESTERN STATES TOOL & SUPPLY	Replacement of Rehab's Old 2 Stroke Wacker Rammer 9/2020	3,283.63
TOTAL CHECKS				148,037.78

CORPORATE CARDS:

GL	DATE	Account Number & Name	Description	Amount
TOTAL CORPORATE CARDS:				0.00

WIRE TRANSFERS

DATE	TO WHOM PAYABLE	PURPOSE	AMOUNT
10/9/2020	PrimePay	Employee Payroll - Pay Period 9/25-10/9/20	106,090.11
10/9/2020	PrimePay	Federal Payroll Taxes	25,233.78
10/9/2020	PrimePay	State Payroll Taxes	8,079.05
10/9/2020	ICMA	Deferred Compensation	8,595.21
10/9/2020	CalPERS	Health Benefits 10/2020	48,295.92
10/15/2020	CalPERS	Retirement 9/2020	44,731.34
10/20/2020	Bank of the West	Bank Fees 9/2020	482.56
WIRE TRANSFERS FROM BoFW CHECKING			241,507.97

WEST BAY SANITARY DISTRICT
 Financial Activity Report
 Withdrawals
 October 8, 2020 through October 20, 2020

<u>Summary</u>		
TOTAL CHECKS		148,037.78
TOTAL CORP CARD		-
TOTAL WIRES		241,507.97
TOTAL WITHDRAWALS		389,545.75

<u>Fund</u>	<u>Summary by Budget Category</u>	
100	Operations	303,768.13
200	Capital	16,890.78
500	SHGCC	68,886.84
		389,545.75

President _____

Secretary _____

WEST BAY SANITARY DISTRICT
Financial Activity Report
Supplemental Purchase Register
October 8, 2020 through October 20, 2020

OPERATING SUPPLIES & OFFICE EXPENSE

<u>CHECK</u>	<u>DATE</u>	<u>VENDOR</u>	<u>DESCRIPTION</u>	<u>AMOUNT</u>
67070	10/13/2020	DEWEY PEST CONTROL	Contract Services - Rodent Control	8,457.00
67072	10/13/2020	GRAINGER	Blower Kit, Battery, Stool, Rope & PPE: Ear Plugs, First Aid Kit, Flare Case, Cartridges 9/2020	2,078.37
67073	10/13/2020	HACH COMPANY	Hach Logger - Upgrading Modem	3,010.00
67081	10/13/2020	CITY OF MENLO PARK-Fuel	Fuel 9/2020	4,779.10
67083	10/13/2020	OMEGA INDUSTRIAL SUPPLY, INC.	Cleaning Solutions, Hand Sanitizer & Wipes 9/2020	2,328.31
67091	10/13/2020	TOWNE FORD SALES	Unit 209: Vehicle Maint. & Unit 226: Repairs 9/2020	1,754.91
67092	10/13/2020	VISION COMMUNICATIONS CO.	Radio Service & Radio Repairs 10/2020	1,274.10
67103	10/20/2020	PONTON INDUSTRIES, INC.	Long Life Batteries, 100 AH 8/2020	1,678.75
67104	10/20/2020	WESTERN STATES TOOL & SUPPLY	Replacement of Rehab's Old 2 Stroke Wacker Rammer 9/2020	3,283.63

MISCELLANEOUS

<u>CHECK</u>	<u>DATE</u>	<u>VENDOR</u>	<u>DESCRIPTION</u>	<u>AMOUNT</u>
67063	10/13/2020	ANDERSON PACIFIC	6-Month Operational Period - RWF SH	63,768.71
67069	10/13/2020	URBANOWICZ, JOHN H.	Return 1yr Construction Deposit; CR 460782, 8/12/19	8,000.00
67097	10/20/2020	EAST BAY MUNI UTILITY DISTRICT	BACWA Membership & Program Fees FY 2020-21	2,458.50
67100	10/20/2020	FREYER & LAURETA	Bayfront Canal Diversion Pipeline Project, North Bay Road & Ringwood CIF Design 9/2020	16,890.78

WEST BAY SANITARY DISTRICT
Expenditures Summary FY 2020-21
7/01/2020 to 10/20/2020

REGULAR PAYABLES	TOTAL BY VENDOR YTD FY 2020-21	WITHDRAWALS 10/08/2020 to 10/20/2020
3T Equipment Company	9,734.93	295.73
A-A Lock & Alarm	215.01	-
AAA Rentals	2,029.13	-
Abila	4,366.00	-
Access	110.00	-
Action Towing	471.00	-
Air & Lube Systems, Inc.	50,121.25	-
All Fence Company, Inc.	1,040.00	-
Alliant Insurance Services	18,218.00	-
Almanac Online	1,056.00	1,056.00
American Messaging	203.66	-
American Textile & Supply	1,959.58	-
Anderson Pacific	651,935.73	63,768.71
Aquality Water Management Inc.	695.14	695.14
Aqua Natural Solutions	1,909.14	-
Arcon Builders	2,000.00	-
AT&T	2,978.01	-
Atchison, Barisone & Condotti	30,906.44	9,340.96
Bank of the West - Credit Card	100,569.49	-
Bank of the West - Bank Fees	879.42	482.56
Bay Alarm	8,837.40	-
Bay Area Air Quality Mgmt Dist	5,852.00	-
Bayside Equipment Company	5,163.47	400.04
Vance Brown	291.25	-
CSRMA c/o Alliant Insurance	160,532.60	-
CWEA	1,807.00	-
California Water Service	6,095.28	2,171.84
CALPERS	1,050.00	-
CALPERS - Unfunded Accrued Liability	1,982,655.00	-
CALPERS - Retirement	156,460.05	44,731.34
CALPERS - Health Premiums	198,689.18	48,295.92
Calpers Long-Term Care Program	247.52	35.36
Center for Hearing Health Inc.	600.00	-
Central Payment	398.56	-
George Choi	9,500.00	-
Cintas Corp.	15,551.26	4,014.28
Comcast	1,109.82	-
Costco Membership	60.00	-
Heath Cortez	225.00	-
Cues, Inc.	3,950.00	-
Custom Lanyard	1,619.40	-
Dell Marketing L.P.	984.00	-
Dewey Pest Control	8,621.00	8,457.00
Dolphin Graphics	1,521.22	-
Du-All Safety, Llc	6,480.00	1,620.00
Duke's Root Control, Inc	131,269.16	-
East Bay Muni Utility District	2,458.50	2,458.50
Embarcadero Media	396.00	-
Emerging Sun Productions	436.00	-
Federal Express	990.69	-
Fremont Urgent Care	2,838.00	-
Finishmaster Inc	1,098.92	-
City of Foster City	1,520.00	1,020.00
Franchise Tax Board	2,000.00	250.00
Freyer & Laureta	261,706.92	16,890.78
Global Equipment, Inc	1,811.15	-
Golden Gate Truck Center	564.31	-

WEST BAY SANITARY DISTRICT
Expenditures Summary FY 2020-21
7/01/2020 to 10/20/2020

REGULAR PAYABLES	TOTAL BY VENDOR	WITHDRAWALS
	YTD FY 2020-21	10/08/2020 to 10/20/2020
Governmentjobs.com dba NeoGov	3,778.32	-
GovConnection, Inc.	780.00	-
Grainger	14,228.30	3,205.50
Granite Rock, Inc.	427.10	-
HF&H Consultants, LLC	9,928.75	-
Hach Company	4,160.72	3,010.00
Hadronex, Inc.	34,632.00	-
Hillyard/San Francisco	481.40	-
Home Depot Credit Services	3,634.08	237.55
Bob Hulsmann	1,096.15	-
IEDA	3,144.00	786.00
Institute for Local Government	350.00	-
Instrument Technology Corp.	7,035.63	-
Interstate Traffic Control	55.99	55.99
Jani-King of CA, Inc - SFR/OAK	2,973.24	743.31
Kantor's Furniture	6,610.63	-
Kimball Midwest	4,809.63	-
Kone Pasadena	1,068.48	267.12
Lasky Trade Printing	142.03	142.03
Log Me In	1,801.98	-
Eric Madrigal	169.10	75.00
Mallory Co.	9,822.63	-
Matheson Tri-Gas, Inc.	212.18	52.28
Meineke	1,580.76	-
Menlo Chevron	790.56	-
City of Menlo Park - Repair	10,190.30	-
City of Menlo Park-Fuel	12,304.43	4,779.10
City of Menlo Park - Water	6,489.86	85.47
Mid State Container Sales, Inc	2,800.00	-
Mission Clay Products, LLC	2,805.65	-
Morse Hydraulics	338.70	-
Municipal Maintenance Equip.	6,432.13	-
National Auto Fleet Club	87,289.71	-
Navia Benefit Solutions	4,278.12	525.39
NeoPost	300.00	-
Carrie Nevoli - Petty Cash	598.06	-
North Bay Pensions	2,500.00	-
R.A. Nosek Investigations	2,065.00	-
Occasions, ETC.	27.75	-
Occupational Health Centers	164.00	-
Ogasawara Landscape Maint.	1,900.00	400.00
Omega Industrial Supply, Inc.	9,282.11	2,328.31
Pacific Gas & Electric	67,026.76	1,066.61
Paytrace	351.14	-
Peninsula Battery Inc.	905.49	333.61
Peninsula Building Supply	1,134.22	116.88
Pier 2 Marketing	800.00	-
Ponton Industries, Inc.	16,900.50	1,678.75
Precise Printing and Mailing	1,931.73	-
Preferred Alliance	1,049.16	-
Principal Life Insurance Co.	14,996.62	-
Priority 1 Public Safety	7,908.96	-
Quadient Leasing USA, Inc.	268.25	-
Sergio Ramirez - Tuition Reimbursement	4,001.62	-
Ranger Pipelines	39,646.99	-
Readyrefresh By Nestle	1,160.85	62.28
Red Wing Business	6,133.15	187.64
Todd Reese	500.00	-

WEST BAY SANITARY DISTRICT
Expenditures Summary FY 2020-21
7/01/2020 to 10/20/2020

REGULAR PAYABLES	TOTAL BY VENDOR	WITHDRAWALS
	YTD FY 2020-21	10/08/2020 to 10/20/2020
Rich Voss Trucking	406.00	-
Roberts & Brune Company	8,503.71	411.17
SVCW Bond - 2014 Bond	391,929.21	-
SVCW Bond - 2015 Bond	1,107,625.00	-
SVCW Bond - 2018 Bond	1,203,293.75	-
SVCW - Monthly Operating Payment	1,910,130.00	-
SVCW - SRF Loan	506,765.21	-
San Mateo County	1,737.00	-
San Mateo County Assessor	305.00	-
San Mateo County Clerk	205.00	-
Henry Santos	150.00	-
Robert J. Scheidt	280.47	-
Seekzen Systems	3,338.80	-
Sharp Business Systems	4,503.21	-
Sharp Electronics Corporation	288.59	288.59
Snap On Industrial	169.75	-
Sonsray Machinery LLC	2,140.51	-
Spartan Tool, LLC	2,317.60	412.22
Staples Credit Plan	4,871.78	-
Steven Creek Quarry, Inc.	720.14	-
Sutter EAP	1,239.75	-
Teamsters Local No. 350	4,140.00	-
Teletrac Navman US Ltd.	553.99	-
Towne Ford Sales	57,077.84	1,754.91
Urbanowicz, John H.	8,000.00	8,000.00
USA Blue Book	428.36	-
V & A Consulting Engineers	7,060.00	-
Vision Communications Co.	3,785.57	1,274.10
Weco Industries, LLC	5,331.27	-
Western States Tool & Supply	3,283.63	3,283.63
Wex Bank (Chevron)	980.85	-
Woodard & Curran	34,665.18	-
Young's Auto Supply Center	190.96	-
Zanker Recycling	51.77	-
TOTAL REGULAR PAYABLES	9,561,503.47	241,547.60
SALARIES, WAGES & WITHHOLDINGS		
Salaries/Wages - Net Pay	862,435.20	106,090.11
Directors Fees - Net Pay	7,356.02	-
PrimePay Fees	2,332.71	-
IRS - Federal Payroll Taxes	195,555.09	25,233.78
EDD - State Payroll Taxes	63,710.74	8,079.05
ICMA	72,878.31	8,595.21
Performance Merit Program - Net Pay	-	-
TOTAL SALARIES RELATED	1,204,268.07	147,998.15
TOTAL WITHDRAWALS	10,765,771.54	389,545.75

WEST BAY SANITARY DISTRICT
Receipts & Incoming Transfers
October 8, 2020 through October 20, 2020

RECEIPT NUMBER	DEPOSIT DATE	DESCRIPTION	AMOUNT
461426	10/20/2020	Permit: 860 Live Oak Ave, MP	290.00
461427	10/20/2020	Invoice 2019/20-075: 883 Santa Cruz Ave, MP	5,131.88
461428	10/20/2020	Inv 2020/21-017: SSC 3350 Alpine Rd, PV	1,224.00
461429	10/20/2020	Inv 2020/21-029: SSC 380 Golden Oak Dr, PV	1,224.00
461430	10/20/2020	Pool Discharge Permit#: NR-0418	434.33
461431	10/20/2020	Permit: 307 Walsh Rd, Ath	290.00
461432	10/20/2020	Permit: 70 Maple Leaf, Ath	170.00
461433	10/20/2020	Permit: 1047 Berkeley Ave, MP	290.00
461434	10/20/2020	Invoice#2020/21-031; SSC 45 Tagus Court	1,694.00
461435	10/20/2020	Invoice# 2020/21-041; SSC 1234 Los Trancos Road	612.00
461436	10/20/2020	Invoice# 2020/21-043; SSC 177 Los Trancos Circle	612.00
461437	10/20/2020	AT&T Settlement Payment	724.16
461438	10/20/2020	Inv 2020/21-035: SSC 145 Bear Gulch Dr, PV	1,224.00
461439	10/20/2020	P. Scott Phone Bill	102.73
461441	10/20/2020	Permit: 98 Moulton Dr, ATH	290.00
461442	10/20/2020	Inv 2020/21-051: SSC 63 Los Trancos Woods Rd, PV	1,224.00
461443	10/20/2020	Inv 2020/21-053: SSC 65 Los Trancos Woods Rd, PV	1,224.00
461444	10/20/2020	Inv 2020/21-050: SSC 850 Los Trancos Rd, PV	612.00
461445	10/20/2020	Inv 2020/21-055: Anderson Pacific	18,088.79
461446	10/20/2020	Inv 2020/21-052: SSC 830 Los Trancos Rd, PV	1,224.00
461447	10/20/2020	Inv 2020/21-021: SSC 5 Grove Ct, PV	1,694.00
461448	10/20/2020	Inv 2020/21-047: SSC 4111 Alpine Rd, PV	1,694.00
461449	10/20/2020	Permit: 1047 Ringwood Ave, MP	290.00
461450	10/20/2020	Permit: 19 Irving Ave, ATH	355.00
461451	10/20/2020	Permit: 2 Leon Way, ATH	290.00
461452	10/20/2020	Postage	0.50
461453	10/20/2020	Pool Permit: 85 McCormick, ATH	523.07
461454	10/20/2020	Permit: 930 Hermosa Way, MP	290.00
461455	10/20/2020	Permit: 6 Knoll Vista, ATH	290.00
Total Deposits			<u><u>\$42,112.46</u></u>
WIRE/ACH TRANSFERS RECEIVED			
461440	10/13/2020	SHGCC - SRF Loan Payment	67,554.09
461458	10/20/2020	Recology	8,562.75
Total Transfer to BofW Checking			<u><u>\$76,116.84</u></u>
TOTAL DEPOSITS			<u><u>\$118,229.30</u></u>

THIS PAGE LEFT INTENTIONALLY BLANK



**WEST BAY SANITARY DISTRICT
AGENDA ITEM 7C**

To: Board of Directors

**From: Sergio Ramirez, District Manager
Debra Fisher, Finance Manager**

**Subject: Consideration to Approve District's Investment Portfolio
Reports Including Transactions of Assets Described Therein as
of 9/30/20**

Background

In October 2010 the District named Bank of the West as the District's Investment advisor and approved an investment of \$5 million in available funds to establish the Emergency Capital Reserve.

There are currently six separate reserves maintained to support the goals of the District. Annual contributions are made in accordance with the board approved budget and the Reserve Replenishment Plan to reach the target balances for each reserve.

<u>Reserve Account</u>	<u>Opened</u>	<u>Target</u>
Operating Reserve	11/26/2014	\$9 million
Rate Stabilization Reserve	10/30/2015	\$8 million
Emergency Capital Reserve	10/19/2010	\$5 million
Capital Project Reserve	11/26/2014	\$6 million
Recycled Water Cash Flow	11/18/2016	
Recycled Water SRF Reserve	3/01/2018	

The Recycled Water SRF Reserve are restricted funds from Sharon Heights Golf and Country Club for the required SRF Loan Reserve.

Additional funds are held in Local Agency Investment Fund (LAIF), including \$7.91 million of funds from the Recycled Water Cash Flow reserve which were transferred, as LAIF's yields outperformed the reserve account. LAIF accounts are equivalent to cash and can earn higher yields without a long term commitment. These funds will be returned to the Investment Portfolio as Bank of the West net returns improve over LAIF.

The District's reserve funds for the first quarter 2020-21:

District Reserves 6/30/2020 - 9/30/2020	Target Balance	Beginning Market Value (millions)	Ending Market Value (millions)	Yield
Operating Reserve	\$9.5 million	\$9.53	\$9.55	2.39%
Emergency Capital Reserve	\$5 million	\$3.90	\$3.92	2.20%
Capital Project Reserve	\$6 million	\$2.78	\$2.79	2.68%
Rate Stabilization Reserve	\$6 million	\$1.41	\$1.41	2.23%
Recycled Water Cash Flow	\$8 million			
Recycled Water Cash Flow Reserve - BofW		\$0.23	\$0.23	2.34%
Recycled Water Cash Flow Reserve - LAIF		\$7.91	\$7.91	0.80%
Recycled Water SRF Reserve		\$1.53	\$1.54	2.25%

Analysis

The District made no transfers in the first quarter 2020-21. Staff will make the budgeted transfer to the Reserve Replenishment Plan, as directed, in 2020-21 and over the next several years to achieve the full target levels set by the Board.

Fiscal Impact

The investment portfolios have been set up with the goal to yield a rate of return of approximately 2%. Current yields in the Investment Reserves exceed this goal, with yields of 2.2% to 2.68%.

Recommendation

The District Manager recommends the District Board approve the report on the District's Investment Portfolio including the transactions of assets described therein as of 9/30/20.



WBSD - OPERATING RESERVE

Account Number: 07/01/20 -
 Statement Period: 09/30/20

WEST BAY SANITARY DISTRICT
 500 LAUREL STREET
 MENLO PARK CA 94025

Fiduciary
 Chuen Ying Lee
 (408) 645-3234
Portfolio
 Michael D. Smith
 (408) 490-2079

Asset Allocation

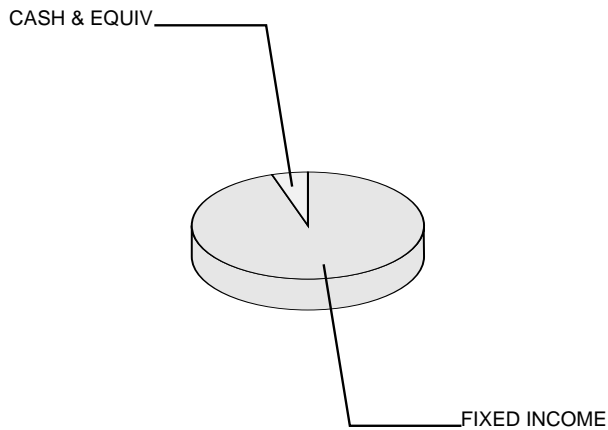

Asset Valuation

Description	Market Value	% of Account
Cash & Equiv	429,682.45	4.5%
Fixed Income	9,068,974.64	95.5%
Total Portfolio	\$ 9,498,657.09	100.0%
Accrued Income	54,174.74	
Total Valuation	\$ 9,552,831.83	

Market Reconciliation

	Current Period	Year To Date
Beginning Market Value	\$ 9,530,903.35	\$ 9,530,903.35
Income		
Interest.....	69,420.89	69,420.89
Purchased Income.....	-6,594.77	-6,594.77
Disbursements.....	-4,786.40	-4,786.40
Realized Gains/(Losses).....	-853.30	-853.30
Change In Accrued Income.....	-6,722.01	-6,722.01
Change In Market Appreciation/(Depreciation).....	-14,075.01	-14,075.01
Non-Cash Asset Changes.....	-14,460.92	-14,460.92
Ending Market Value	\$ 9,552,831.83	\$ 9,552,831.83



WBSD - OPERATING RESERVE

Account Number:
Statement Period:

07/01/20 -
09/30/20

Asset Position As of 09/30/20

Asset Description	Units	Market Value Cost	Est. Annual Income Accruals	Current Yield
Cash Equivalents				
Bank of The West Advantage Acct	429,682.450	429,682.45 429,682.45	300.00 12.52	0.07%
Total Cash Equivalents		\$ 429,682.45 \$ 429,682.45	300.00 12.52	0.07%
Fixed Income				
Anz National Intl LTD Fr 3.40% Dtd 03/19/2019 Due 03/19/2024 Non-Callable	100,000.000	108,779.00 108,966.00	3,400.00 113.33	3.13%
Alabama St GO Ref Bds 2014 A 5.00% Dtd 08/06/2014 Due 08/01/2022 Non-Callable	75,000.000	81,618.00 80,746.50	3,750.00 625.00	4.59%
American Express Co Sr Glbl 2.50% Dtd 07/30/2019 Due 07/30/2024 Callable	100,000.000	106,433.00 105,596.00	2,500.00 423.61	2.35%
Apple Inc Sr Glbl Nt 0.75% Dtd 05/11/2020 Due 05/11/2023 Callable	20,000.000	20,204.00 20,237.40	150.00 58.33	0.74%
Atlantic Richfield Co Deb 8.25% Dtd 02/01/1992 Due 02/01/2022 Non-Callable	15,000.000	16,364.70 16,234.20	1,237.00 206.25	7.56%
Austin Tex Pub Ppty Fin Contractual 5.00% Dtd 10/03/2018 Due 11/01/2021 Non-Callable	85,000.000	89,459.10 89,983.55	4,250.00 1,770.83	4.75%
Autozone Inc Sr Glbl 2.50% Dtd 04/29/2015 Due 04/15/2021 Callable	45,000.000	45,447.30 45,603.90	1,125.00 518.75	2.48%
Blackrock Inc Sr Nt 3.50% Dtd 03/18/2014 Due 03/18/2024 Callable	100,000.000	110,201.00 110,370.00	3,500.00 126.38	3.18%
Clackamas Cnty Ore Sch Dist No GO Ref Bds 5.00% Dtd 06/13/2017 Due 06/15/2021 Non-Callable	75,000.000	77,553.75 77,923.50	3,750.00 1,104.16	4.84%
Colorado St Brd Governors Univ Rev Ref Bds 2012b 5.00% Dtd 05/01/2012 Due 03/01/2023 Non-Callable	125,000.000	139,505.00 136,340.00	6,250.00 520.83	4.48%



WBSD - OPERATING RESERVE

Account Number:
Statement Period:

07/01/20 -
09/30/20

Asset Position As of 09/30/20

Asset Description	Units	Market Value Cost	Est. Annual Income Accruals	Current Yield
Credit Suisse Ag New York Bran Fr 2.80% Dtd 04/09/2020 Due 04/08/2022 Non-Callable	40,000.000	41,421.20 41,457.60	1,120.00 535.11	2.70%
Deere John Capital Corp Fr 3.45% Dtd 03/13/2018 Due 03/13/2025 Non-Callable	90,000.000	101,363.40 101,255.40	3,105.00 155.25	3.06%
Disney Walt Co Sr Gbl Nt 1.65% Dtd 09/06/2019 Due 09/01/2022 Callable	35,000.000	35,836.50 35,659.75	577.00 48.12	1.61%
Exxon Mobil Corp Sr Gbl Nt 1.902% Dtd 08/16/2019 Due 08/16/2022 Callable	35,000.000	36,036.70 36,016.05	665.00 83.21	1.85%
Fyi Pptys Wash Lease Rev Ref Bds 5.00% Dtd 03/05/2019 Due 06/01/2021 Non-Callable	100,000.000	103,128.00 103,501.00	5,000.00 1,666.66	4.85%
Federal Home Loan Bks Cons Bds 1.875% Dtd 11/30/2016 Due 11/29/2021 Non-Callable	200,000.000	204,044.00 198,831.96	3,750.00 1,270.83	1.84%
Federal Home Loan Bks Cons Bds 1.85% Dtd 08/15/2017 Due 08/15/2022 Non-Callable	235,000.000	242,191.00 235,780.20	4,347.00 555.51	1.80%
Federal Farm Cr Bks Cons Systemwide Bds 2.40% Dtd 06/17/2015 Due 06/17/2022 Non-Callable	235,000.000	243,991.10 237,848.20	5,640.00 1,629.33	2.31%
Federal Farm Cr Bks Cons Systemwide Bds 1.72% Dtd 07/26/2017 Due 07/26/2021 Non-Callable	235,000.000	238,031.50 235,185.65	4,042.00 729.80	1.70%
Federal Farm Cr Bks Cons Systemwide Bds 1.54% Dtd 02/03/2020 Due 02/03/2022 Callable	100,000.000	100,396.00 100,000.00	1,540.00 248.11	1.53%
Federal Home Loan Bks Cons Bds 1.625% Dtd 11/07/2012 Due 12/10/2021 Non-Callable	235,000.000	239,211.20 234,353.75	3,818.00 1,177.44	1.60%
Federal Natl Mtg Assn 1.50% Dtd 10/19/2015 Due 11/30/2020 Non-Callable	150,000.000	150,348.00 149,669.90	2,250.00 756.25	1.50%
Federal Natl Mtg Assn 1.875% Dtd 11/16/2015 Due 12/28/2020 Non-Callable	60,000.000	60,244.80 60,191.40	1,125.00 290.62	1.87%



WBSD - OPERATING RESERVE

Account Number:
Statement Period:

- 07/01/20 -
09/30/20

Asset Position As of 09/30/20

Asset Description	Units	Market Value Cost	Est. Annual Income Accruals	Current Yield
Federal Natl Mtg Assn 1.375% Dtd 02/05/2016 Due 02/26/2021 Non-Callable	325,000.000	326,651.00 323,259.10	4,468.00 434.46	1.37%
Federal Natl Mtg Assn 1.25% Dtd 05/16/2016 Due 05/06/2021 Non-Callable	290,000.000	291,945.90 289,027.93	3,625.00 1,460.06	1.24%
Federal Natl Mtg Assn 1.375% Dtd 10/07/2016 Due 10/07/2021 Non-Callable	325,000.000	329,088.50 323,531.94	4,468.00 2,159.89	1.36%
Federal Natl Mtg Assn 2.00% Dtd 01/09/2017 Due 01/05/2022 Non-Callable	505,000.000	517,170.50 505,725.09	10,100.00 2,412.77	1.95%
Federal Natl Mtg Assn 1.875% Dtd 04/10/2017 Due 04/05/2022 Non-Callable	160,000.000	164,238.40 160,716.80	3,000.00 1,466.66	1.83%
Federal Home Ln Mtg Corp 2.375% Dtd 01/13/2012 Due 01/13/2022 Non-Callable	325,000.000	334,382.75 328,316.00	7,718.00 1,672.39	2.31%
GE Capital Internotes Fr 5.50% Dtd 11/05/2009 Due 11/15/2021 Non-Callable	50,000.000	52,105.00 52,287.50	2,750.00 1,038.88	5.28%
Harley Davidson Finl Svcs Inc Fr 2.55% Dtd 06/09/2017 Due 06/09/2022 Callable	70,000.000	71,185.10 70,455.00	1,785.00 555.32	2.51%
Home Depot Inc Sr Glbl Nt 2.00% Dtd 02/12/2016 Due 04/01/2021 Callable	50,000.000	50,368.00 49,899.00	1,000.00 500.00	1.99%
JPMorgan Chase & Co Sr Nt 3.25% Dtd 09/24/2012 Due 09/23/2022 Non-Callable	35,000.000	36,994.30 36,628.55	1,137.00 25.27	3.07%
Jackson Cnty MO Reorg Sch Dist GO Sch Bldg Bds 2009c Taxable 4.90% Dtd 11/15/2009 Due 03/01/2021 Callable	120,000.000	121,838.40 121,945.20	5,880.00 489.99	4.83%
LA Canada Calif Uni Sch Dist Taxable GO Ref Bds Taxable 1.55% Dtd 04/28/2020 Due 08/01/2022 Non-Callable	30,000.000	30,552.00 30,000.00	465.00 77.50	1.52%



WBSD - OPERATING RESERVE

Account Number:
Statement Period:

07/01/20 -
09/30/20

Asset Position As of 09/30/20

Asset Description	Units	Market Value Cost	Est. Annual Income Accruals	Current Yield
LA Canada Calif Uni Sch Dist Taxable GO Ref Bds Taxable 1.65% Dtd 04/28/2020 Due 08/01/2023 Non-Callable	60,000.000	61,744.20 60,000.00	990.00 165.00	1.60%
League City Tex Combi Tax and Rev Ctfs O 5.00% Dtd 07/01/2017 Due 02/15/2023 Non-Callable	140,000.000	155,556.80 152,881.40	7,000.00 894.44	4.50%
Los Angeles Calif Mun Impt COR Bds 2019a 5.00% Dtd 06/26/2019 Due 11/01/2023 Non-Callable	65,000.000	74,488.05 72,744.90	3,250.00 1,354.16	4.36%
Michigan St GO Ref Bds 2009a Taxable 6.95% Dtd 04/14/2009 Due 11/01/2020 Non-Callable	25,000.000	25,136.50 25,645.50	1,737.00 723.95	6.91%
Morgan Stanley Fr 5.75% Dtd 01/25/2011 Due 01/25/2021 Callable	45,000.000	45,769.05 46,171.35	2,587.00 474.37	5.65%
Ncua Guaran Nts Tr Ser 2010 R1 Cl I A Fltg Rate Dtd 10/27/2010 Due 10/07/2020	56,463.680	56,457.79 56,604.84	351.00 26.38	0.62%
New Hampshire Health & Ed Facs Taxable Univ Sys Issue B 2017 B Taxable 2.292% Dtd 12/06/2017 Due 07/01/2021 Non-Callable	25,000.000	25,370.50 25,107.50	573.00 143.25	2.26%
New York Life Gbl Fdg MTN 144a Sr Sec Gbl 1.10% Dtd 05/07/2020 Due 05/05/2023 Non-Callable	90,000.000	91,516.50 91,752.30	990.00 396.00	1.08%
New York N Y GO Bds 2010 D Taxable 5.199% Dtd 12/17/2009 Due 12/01/2022 Callable	60,000.000	65,699.40 65,373.50	3,119.00 1,039.80	4.75%
New York St Dorm Auth Revs Non Univ Rev Bds 2019b Taxable 2.839% Dtd 02/21/2019 Due 07/01/2022 Callable	50,000.000	51,670.00 51,105.00	1,419.00 354.87	2.75%
New York St Dorm Auth St Pers Income Tax Rev Bds 2010c Taxable 4.554% Dtd 03/11/2010 Due 02/15/2021 Callable	25,000.000	25,371.25 25,311.50	1,138.00 145.47	4.49%
Ohio St Common Schs GO Ref Bds 2016 A 5.00% Dtd 03/09/2016 Due 12/15/2023 Non-Callable	45,000.000	51,941.70 50,612.85	2,250.00 662.50	4.33%



WBSD - OPERATING RESERVE

Account Number:
Statement Period:

07/01/20 - 09/30/20

Asset Position As of 09/30/20

Asset Description	Units	Market Value Cost	Est. Annual Income Accruals	Current Yield
Port Morrow Ore Transmission F Rev Bds Taxable 2.737% Dtd 08/26/2015 Due 09/01/2021 Callable	200,000.000	204,530.00 202,206.00	5,474.00 456.16	2.68%
Royal Bk of Cda Bd Cds Fr 3.20% Dtd 04/30/2018 Due 04/30/2021 Non-Callable	81,000.000	82,377.00 82,607.57	2,592.00 1,087.20	3.15%
San Francisco Calif City & Cnt Taxable Ref Bds 2019 A Taxable 1.814% Dtd 01/09/2020 Due 11/01/2020 Callable	50,000.000	50,060.50 50,025.00	907.00 660.09	1.81%
Santa Ana Calif Fing Auth Wtr Ref Bds 5.00% Dtd 08/07/2014 Due 09/01/2022 Non-Callable	50,000.000	54,673.00 53,435.00	2,500.00 208.33	4.57%
Seattle Wash GO Ref Bds 5.00% Dtd 05/16/2012 Due 12/01/2021 Non-Callable	100,000.000	105,650.00 105,786.00	5,000.00 1,666.66	4.73%
Small Business Admin Gtd Ln Pool Cfcs 2.245% Dtd 09/19/2012 Due 09/10/2022	135,472.290	137,251.04 137,213.32	3,041.00 285.76	2.22%
Southwest Tex Indpt Sch Dist Ultd Tax Sch Bldg and RE 5.00% Dtd 07/15/2014 Due 02/01/2022 Non-Callable	110,000.000	117,103.80 116,459.20	5,500.00 916.66	4.70%
Starbucks Corp Sr Gbl 2.10% Dtd 02/04/2016 Due 02/04/2021 Callable	50,000.000	50,233.00 49,987.00	1,050.00 166.25	2.09%
State Str Corp Sr Sb Nt 3.10% Dtd 05/15/2013 Due 05/15/2023 Non-Callable	90,000.000	95,939.10 96,356.70	2,790.00 1,054.00	2.91%
3M Co Fr 2.00% Dtd 06/26/2012 Due 06/26/2022 Non-Callable	100,000.000	102,927.00 99,535.05	2,000.00 527.77	1.94%
Toyota Motor Credit Corp Fr 2.90% Dtd 04/01/2020 Due 03/30/2023 Non-Callable	40,000.000	42,410.00 41,907.20	1,160.00 3.22	2.74%
Toyota Motor Credit Corp Fr 3.00% Dtd 04/01/2020 Due 04/01/2025 Callable	190,000.000	207,793.50 209,052.00	5,700.00 2,849.99	2.74%



WBSD - OPERATING RESERVE

Account Number:
Statement Period:

07/01/20 -
09/30/20

Asset Position As of 09/30/20

Asset Description	Units	Market Value Cost	Est. Annual Income Accruals	Current Yield
United Parcel Service Inc Sr Nt 2.50% Dtd 11/14/2017 Due 04/01/2023 Callable	90,000.000	94,548.60 94,637.70	2,250.00 1,124.99	2.38%
US Treasury Note 1.625% Dtd 11/30/2015 Due 11/30/2020	425,000.000	426,062.50 423,147.79	6,906.00 2,320.95	1.62%
US Treasury Note 1.125% Dtd 01/15/2011 Due 01/15/2021 Treasury Inflation Protection Security	118,425.000	119,173.45 117,793.09	1,332.00 280.42	1.12%
US Treasury Note 0.125% Dtd 04/15/2016 Due 04/15/2021 Treasury Inflation Protection Security	98,373.600	98,805.46 98,137.04	122.00 56.45	0.12%
US Treasury Note 1.125% Dtd 06/30/2016 Due 06/30/2021	100,000.000	100,758.00 100,348.97	1,125.00 284.30	1.12%
US Treasury Note 1.875% Dtd 12/15/2017 Due 12/15/2020	220,000.000	220,796.40 221,151.36	4,125.00 1,217.21	1.87%
US Treasury Note 2.375% Dtd 03/15/2018 Due 03/15/2021	100,000.000	101,036.00 100,778.84	2,375.00 104.97	2.35%
US Treasury Note 2.75% Dtd 09/15/2018 Due 09/15/2021	100,000.000	102,502.00 99,695.31	2,750.00 121.54	2.68%
US Treasury Note 2.50% Dtd 01/31/2019 Due 01/31/2021	200,000.000	201,586.00 200,837.07	5,000.00 842.39	2.48%
University Calif Revs Gen Rev Bds 2015 A Taxable 2.909% Dtd 03/25/2015 Due 05/15/2023 Callable	135,000.000	143,577.90 141,370.65	3,927.00 1,483.59	2.74%
Walnut Calif Energy Ctr Auth R Ref Bds 2014a 5.00% Dtd 07/23/2014 Due 01/01/2022 Non-Callable	65,000.000	68,943.55 68,560.70	3,250.00 812.50	4.71%
Washington St Various Purp GO Ref Bds R 5.00% Dtd 07/14/2016 Due 08/01/2022 Non-Callable	100,000.000	108,882.00 107,805.00	5,000.00 833.33	4.59%
Waxahachie Tex Comb Tax Rev Cfts Oblig 5.00% Dtd 09/19/2018 Due 08/01/2021 Non-Callable	125,000.000	129,997.50 129,771.25	6,250.00 1,041.66	4.81%
Wells Fargo & Co New Sr Gbl 2.50% Dtd 03/04/2016 Due 03/04/2021 Non-Callable	250,000.000	252,307.50 248,550.00	6,250.00 468.74	2.48%



WBSD - OPERATING RESERVE

Account Number:
 Statement Period:

07/01/20 -
 09/30/20

Asset Position As of 09/30/20

Asset Description	Units	Market Value Cost	Est. Annual Income Accruals	Current Yield
Total Fixed Income		\$ 9,068,974.64 \$ 8,974,009.47	227,067.00 54,162.22	2.50%
Cash				
Principal Cash		0.00 0.00	0.00	0.00%
Income Cash		0.00 0.00	0.00	0.00%
Total Cash		\$ 0.00 \$ 0.00	0.00 0.00	0.00%
Total Market Value		\$ 9,498,657.09 \$ 9,403,691.92	227,367.00 54,174.74	2.39%
Total Market Value Plus Accruals		\$ 9,552,831.83		

Income Activity

	Date	Income Cash	Principal Cash
Interest Income			
Bank of The West Advantage Acct			
Int To 06/30/20	07/01/20		36.67
Int To 07/31/20	08/03/20		40.03
Int To 08/31/20	09/01/20		43.16
Anz National Intl LTD Fr 3.40% Dtd 03/19/2019 Due 03/19/2024 Non-Callable			
Int To 09/19/20 on 100,000	09/21/20		1,700.00
Alabama St GO Ref Bds 2014 A 5.00% Dtd 08/06/2014 Due 08/01/2022 Non-Callable			
Int To 08/01/20 on 75,000	08/03/20		1,875.00
American Express Co Sr Glbl 2.50% Dtd 07/30/2019 Due 07/30/2024 Callable			
Int To 07/30/20 on 100,000	07/30/20		1,250.00
Atlantic Richfield Co Deb 8.25% Dtd 02/01/1992 Due 02/01/2022 Non-Callable			
Int To 08/01/20 on 15,000	08/03/20		618.75



WBSD - OPERATING RESERVE

Account Number:
Statement Period:

07/01/20 -
09/30/20

Income Activity			
	Date	Income Cash	Principal Cash
Blackrock Inc Sr Nt 3.50% Dtd 03/18/2014 Due 03/18/2024 Callable Int To 09/18/20 on 100,000	09/18/20		1,750.00
Capital One Bk USA Natl Assn CTF Dep 1.40% Dtd 09/28/2016 Due 09/28/2020 Non-Callable Int To 09/28/20 on 100,000	09/28/20		705.75
Colorado St Brd Governors Univ Rev Ref Bds 2012b 5.00% Dtd 05/01/2012 Due 03/01/2023 Non-Callable Int To 09/01/20 on 125,000	09/01/20		3,125.00
Deere John Capital Corp Fr 3.45% Dtd 03/13/2018 Due 03/13/2025 Non-Callable Int To 09/13/20 on 90,000	09/14/20		1,552.50
Disney Walt Co Sr Glbl Nt 1.65% Dtd 09/06/2019 Due 09/01/2022 Callable Int To 09/01/20 on 35,000	09/01/20		288.75
Exxon Mobil Corp Sr Glbl Nt 1.902% Dtd 08/16/2019 Due 08/16/2022 Callable Int To 08/16/20 on 35,000	08/17/20		332.85
Federal Home Loan Bks Cons Bds 1.85% Dtd 08/15/2017 Due 08/15/2022 Non-Callable Int To 08/15/20 on 235,000	08/17/20		2,173.75
Federal Farm Cr Bks Cons Systemwide Bds 1.72% Dtd 07/26/2017 Due 07/26/2021 Non-Callable Int To 07/26/20 on 235,000	07/27/20		2,021.00
Federal Farm Cr Bks Cons Systemwide Bds 1.54% Dtd 02/03/2020 Due 02/03/2022 Callable Int 02/03/20 To 08/03/20 on 100000	08/03/20		770.00
Federal Home Loan Bks Cons Bds 2.875% Dtd 08/27/2010 Due 09/11/2020 Non-Callable Int To 09/11/20 on 60,000	09/11/20		862.50



WBSD - OPERATING RESERVE

Account Number:
 Statement Period:

07/01/20 -
 09/30/20

Income Activity			
	Date	Income Cash	Principal Cash
Federal Home Ln Mtg Corp Medium Term Nts 1.625% Dtd 04/27/2017 Due 07/27/2020 Callable Reversed on 08/05/2020	07/27/20		325.00
Interest At Maturity of To Reverse Entry of 07/27/20	08/05/20		-325.00
Interest At Maturity of	08/13/20		162.50
Federal Natl Mtg Assn 1.375% Dtd 02/05/2016 Due 02/26/2021 Non-Callable Int To 08/26/20 on 325,000	08/26/20		2,234.37
Federal Natl Mtg Assn 2.00% Dtd 01/09/2017 Due 01/05/2022 Non-Callable Int To 07/05/20 on 505,000	07/06/20		5,050.00
Federal Home Ln Mtg Corp 2.375% Dtd 01/13/2012 Due 01/13/2022 Non-Callable Int To 07/13/20 on 325,000	07/13/20		3,859.37
Indiana Univ Revs Student Fee Bds V Taxable 2.227% Dtd 10/26/2012 Due 08/01/2020 Callable Int To 08/01/20 on 25,000	08/03/20		278.37
JPMorgan Chase & Co Sr Nt 3.25% Dtd 09/24/2012 Due 09/23/2022 Non-Callable Int To 09/23/20 on 35,000	09/23/20		568.75
Jackson Cnty MO Reorg Sch Dist GO Sch Bldg Bds 2009c Taxable 4.90% Dtd 11/15/2009 Due 03/01/2021 Callable Int To 09/01/20 on 120,000	09/01/20		2,940.00
LA Canada Calif Uni Sch Dist Taxable GO Ref Bds Taxable 1.55% Dtd 04/28/2020 Due 08/01/2022 Non-Callable Int 04/28/20 To 08/01/20 on 30000	08/03/20		120.12
LA Canada Calif Uni Sch Dist Taxable GO Ref Bds Taxable 1.65% Dtd 04/28/2020 Due 08/01/2023 Non-Callable Int 04/28/20 To 08/01/20 on 60000	08/03/20		255.75



WBSD - OPERATING RESERVE

Account Number:
Statement Period:

07/01/20 -
09/30/20

Income Activity			
	Date	Income Cash	Principal Cash
League City Tex Combi Tax and Rev Cffs O 5.00% Dtd 07/01/2017 Due 02/15/2023 Non-Callable Int To 08/15/20 on 140,000	08/17/20		3,500.00
Morgan Stanley Fr 5.75% Dtd 01/25/2011 Due 01/25/2021 Callable Int To 07/25/20 on 45,000	07/27/20		1,293.75
Ncua Guarant Nts Tr Ser 2010 R1 Cl I A Fltg Rate Dtd 10/27/2010 Due 10/07/2020 Int To 07/08/20 on 63148.84 Int To 08/06/20 on 61708.69 Int To 09/04/20 on 58868.53	07/08/20 08/06/20 09/04/20		36.10 30.61 28.42
New Hampshire Health & Ed Facs Taxable Univ Sys Issue B 2017 B Taxable 2.292% Dtd 12/06/2017 Due 07/01/2021 Non-Callable Int To 07/01/20 on 25,000	07/01/20		286.50
New York St Dorm Auth Revs Non Univ Rev Bds 2019b Taxable 2.839% Dtd 02/21/2019 Due 07/01/2022 Callable Int To 07/01/20 on 50,000	07/01/20		709.75
New York St Dorm Auth St Pers Income Tax Rev Bds 2010c Taxable 4.554% Dtd 03/11/2010 Due 02/15/2021 Callable Int To 08/15/20 on 25,000	08/17/20		569.25
Port Morrow Ore Transmission F Rev Bds Taxable 2.737% Dtd 08/26/2015 Due 09/01/2021 Callable Int To 09/01/20 on 200,000	09/01/20		2,737.00
Santa Ana Calif Fing Auth Wtr Ref Bds 5.00% Dtd 08/07/2014 Due 09/01/2022 Non-Callable Int To 09/01/20 on 50,000	09/01/20		1,250.00
Small Business Admin Gtd Ln Pool Cffs 2.245% Dtd 09/19/2012 Due 09/10/2022 Int To 09/02/20 on 219554.76	09/10/20		2,484.76



WBSD - OPERATING RESERVE

Account Number:
Statement Period:

07/01/20 -
09/30/20

Income Activity			
	Date	Income Cash	Principal Cash
Southwest Tex Indpt Sch Dist Ultl Tax Sch Bldg and RE 5.00% Dtd 07/15/2014 Due 02/01/2022 Non-Callable Int To 08/01/20 on 110,000	08/03/20		2,750.00
Starbucks Corp Sr Gbl 2.10% Dtd 02/04/2016 Due 02/04/2021 Callable Int To 08/04/20 on 50,000	08/04/20		525.00
Toronto Dominion Bank Fr 2.00% Dtd 01/31/2020 Due 01/31/2023 Callable Int To 07/30/20 on 100,000	07/31/20		500.00
Toyota Motor Credit Corp Fr 2.90% Dtd 04/01/2020 Due 03/30/2023 Non-Callable Int 04/01/20 To 09/30/20 on 40000	09/30/20		576.78
US Treasury Note 1.125% Dtd 01/15/2011 Due 01/15/2021 Treasury Inflation Protection Security Int To 07/15/20 on 117206	07/15/20		659.28
US Treasury Note 2.00% Dtd 07/31/2013 Due 07/31/2020 Int To 07/31/20 on 40,000	07/31/20		400.00
US Treasury Note 1.375% Dtd 09/15/2017 Due 09/15/2020 Int To 09/15/20 on 150,000	09/15/20		1,031.25
US Treasury Note 2.375% Dtd 03/15/2018 Due 03/15/2021 Int To 09/15/20 on 100,000	09/15/20		1,187.50
US Treasury Note 2.75% Dtd 09/15/2018 Due 09/15/2021 Int To 09/15/20 on 100,000	09/15/20		1,375.00
US Treasury Note 2.50% Dtd 01/31/2019 Due 01/31/2021 Int To 07/31/20 on 200,000	07/31/20		2,500.00
Walnut Calif Energy Ctr Auth R Ref Bds 2014a 5.00% Dtd 07/23/2014 Due 01/01/2022 Non-Callable Int To 07/01/20 on 65,000	07/01/20		1,625.00



WBSD - OPERATING RESERVE

Account Number:
 Statement Period:

07/01/20 -
 09/30/20

Income Activity			
	Date	Income Cash	Principal Cash
Washington St Various Purp GO Ref Bds R 5.00% Dtd 07/14/2016 Due 08/01/2022 Non-Callable Int To 08/01/20 on 100,000	08/03/20		2,500.00
Waxahachie Tex Comb Tax Rev Cfts Oblig 5.00% Dtd 09/19/2018 Due 08/01/2021 Non-Callable Int To 08/01/20 on 125,000	08/03/20		3,125.00
Wells Fargo & Co New Sr Gbl 2.50% Dtd 03/04/2016 Due 03/04/2021 Non-Callable Int To 09/04/20 on 250,000	09/04/20		3,125.00
Total Interest Income		\$ 0.00	\$ 69,420.89
Purchased Income			
Anz National Intl LTD Fr 3.40% Dtd 03/19/2019 Due 03/19/2024 Non-Callable Accrued Int To 08/26/20 Paid on Purchase of 100,000	08/26/20		-1,482.78
Blackrock Inc Sr Nt 3.50% Dtd 03/18/2014 Due 03/18/2024 Callable Accrued Int To 08/26/20 Paid on Purchase of 100,000	08/26/20		-1,536.11
Deere John Capital Corp Fr 3.45% Dtd 03/13/2018 Due 03/13/2025 Non-Callable Accrued Int To 08/26/20 Paid on Purchase of 90,000	08/26/20		-1,405.88
New York Life Gbl Fdg MTN 144a Sr Sec Gbl 1.10% Dtd 05/07/2020 Due 05/05/2023 Non-Callable Accrued Int To 08/26/20 Paid on Purchase of 90,000	08/26/20		-299.75
State Str Corp Sr Sb Nt 3.10% Dtd 05/15/2013 Due 05/15/2023 Non-Callable Accrued Int To 08/26/20 Paid on Purchase of 90,000	08/26/20		-782.75



WBSD - OPERATING RESERVE

Account Number:
 Statement Period:

07/01/20 -
 09/30/20

Income Activity			
	Date	Income Cash	Principal Cash
Toyota Motor Credit Corp Fr 3.00% Dtd 04/01/2020 Due 04/01/2025 Callable Accrued Int To 08/26/20 Paid on Purchase of 90,000	08/26/20		-1,087.50
Total Purchased Income		\$ 0.00	\$ -6,594.77
Total Income		\$ 0.00	\$ 62,826.12

Disbursement Activity			
	Date	Income Cash	Principal Cash
Fees/Expenses			
Monthly Fee To 06/30/20	07/15/20		-1,593.81
Monthly Fee To 07/31/20	08/14/20		-1,596.30
Monthly Fee To 08/31/20	09/15/20		-1,596.29
Total Fees/Expenses		\$ 0.00	\$ -4,786.40
Total Disbursements		\$ 0.00	\$ -4,786.40

Purchase Activity			
	Date	Income Cash	Principal Cash
Bank of The West Advantage Acct Purchases (25) 07/01/20 To 09/30/20	09/30/20		-673,279.15
Anz National Intl LTD Fr 3.40% Dtd 03/19/2019 Due 03/19/2024 Non-Callable Purchased 100000 08/24/20 From BNY Mellon/Toronto Dominion Sec @ 109.128	08/26/20		-109,128.00
Blackrock Inc Sr Nt 3.50% Dtd 03/18/2014 Due 03/18/2024 Callable Purchased 100000 08/24/20 From BNY Mellon/Toronto Dominion Sec @ 110.549	08/26/20		-110,549.00



WBSD - OPERATING RESERVE

Account Number:
 Statement Period:

07/01/20 -
 09/30/20

Purchase Activity			
	Date	Income Cash	Principal Cash
Deere John Capital Corp Fr 3.45% Dtd 03/13/2018 Due 03/13/2025 Non-Callable Purchased 90000 08/24/20 From BNY Mellon/Toronto Dominion Sec @ 112.635	08/26/20		-101,371.50
New York Life Gbl Fdg MTN 144a Sr Sec Gbl 1.10% Dtd 05/07/2020 Due 05/05/2023 Non-Callable Purchased 90000 08/24/20 From BNY Mellon/Toronto Dominion Sec @ 101.947	08/26/20		-91,752.30
State Str Corp Sr Sb Nt 3.10% Dtd 05/15/2013 Due 05/15/2023 Non-Callable Purchased 90000 08/24/20 From BNY Mellon/Toronto Dominion Sec @ 107.063	08/26/20		-96,356.70
Toyota Motor Credit Corp Fr 3.00% Dtd 04/01/2020 Due 04/01/2025 Callable Purchased 90000 08/24/20 From BNY Mellon/Toronto Dominion Sec @ 110.21	08/26/20		-99,189.00
Total Purchases		\$ 0.00	\$ -1,281,625.65

Sale Activity			
	Date	Proceeds	Realized Gain/Loss
Bank of The West Advantage Acct Sales (6) 07/01/20 To 09/30/20	09/30/20	617,818.30	
Capital One Bk USA Natl Assn CTF Dep 1.40% Dtd 09/28/2016 Due 09/28/2020 Non-Callable Recd Proceeds on Maturity of 100,000 Par Value	09/28/20	100,000.00	
Federal Home Loan Bks Cons Bds 2.875% Dtd 08/27/2010 Due 09/11/2020 Non-Callable Recd Proceeds on Maturity of 60,000 Par Value	09/11/20	60,000.00	



WBSD - OPERATING RESERVE

Account Number:
 Statement Period:

07/01/20 -
 09/30/20

Sale Activity			
	Date	Proceeds	Realized Gain/Loss
Federal Home Ln Mtg Corp Medium Term Nts 1.625% Dtd 04/27/2017 Due 07/27/2020 Callable Recd Proceeds on Maturity of 40,000 Par Value	07/27/20	40,000.00	
Indiana Univ Revs Student Fee Bds V Taxable 2.227% Dtd 10/26/2012 Due 08/01/2020 Callable Recd Proceeds on Maturity of 25,000 Par Value	08/03/20	25,000.00	
Ncua Guaran Nts Tr Ser 2010 R1 CI I A Fltg Rate Dtd 10/27/2010 Due 10/07/2020 Prin Pmt For 07/08/20	07/08/20	1,440.15	-3.60
Prin Pmt For 08/06/20	08/06/20	2,840.16	-7.10
Prin Pmt For 09/04/20	09/04/20	2,404.85	-6.01
Small Business Admin Gtd Ln Pool Cfcs 2.245% Dtd 09/19/2012 Due 09/10/2022 Prin Pmt For 09/02/20	09/10/20	84,082.47	-1,080.59
Toronto Dominion Bank Fr 2.00% Dtd 01/31/2020 Due 01/31/2023 Callable Full Call @ 100 on 7/31/2020 100,000 Par Value	07/31/20	100,000.00	244.00
US Treasury Note 2.00% Dtd 07/31/2013 Due 07/31/2020 Recd Proceeds on Maturity of 40,000 Par Value	07/31/20	40,000.00	
US Treasury Note 1.375% Dtd 09/15/2017 Due 09/15/2020 Recd Proceeds on Maturity of 150,000 Par Value	09/15/20	150,000.00	
Total Sales		\$ 1,223,585.93	\$ -853.30

Non-Cash Activity		
	Date	Cost
Anz National Intl LTD Fr 3.40% Dtd 03/19/2019 Due 03/19/2024 Non-Callable Amortization of Premium	09/18/20	-162.00



WBSD - OPERATING RESERVE

Account Number:
Statement Period:

07/01/20 -
09/30/20

Non-Cash Activity		
	Date	Cost
Alabama St GO Ref Bds 2014 A 5.00% Dtd 08/06/2014 Due 08/01/2022 Non-Callable Amortization of Premium	08/03/20	-715.50
American Express Co Sr Gbl 2.50% Dtd 07/30/2019 Due 07/30/2024 Callable Amortization of Premium	07/30/20	-156.00
Atlantic Richfield Co Deb 8.25% Dtd 02/01/1992 Due 02/01/2022 Non-Callable Amortization of Premium	08/03/20	-400.80
Blackrock Inc Sr Nt 3.50% Dtd 03/18/2014 Due 03/18/2024 Callable Amortization of Premium	09/18/20	-179.00
Colorado St Brd Governors Univ Rev Ref Bds 2012b 5.00% Dtd 05/01/2012 Due 03/01/2023 Non-Callable Amortization of Premium	09/01/20	-1,482.50
Deere John Capital Corp Fr 3.45% Dtd 03/13/2018 Due 03/13/2025 Non-Callable Amortization of Premium	09/11/20	-116.10
Disney Walt Co Sr Gbl Nt 1.65% Dtd 09/06/2019 Due 09/01/2022 Callable Amortization of Premium	09/01/20	-82.95
Exxon Mobil Corp Sr Gbl Nt 1.902% Dtd 08/16/2019 Due 08/16/2022 Callable Amortization of Premium	08/14/20	-104.30
Federal Home Loan Bks Cons Bds 1.85% Dtd 08/15/2017 Due 08/15/2022 Non-Callable Amortization of Premium	08/14/20	-192.70
Federal Farm Cr Bks Cons Systemwide Bds 1.72% Dtd 07/26/2017 Due 07/26/2021 Non-Callable Amortization of Premium	07/24/20	-91.65



WBSD - OPERATING RESERVE

Account Number:
Statement Period:

07/01/20 -
09/30/20

Non-Cash Activity		
	Date	Cost
Federal Home Loan Bks Cons Bds 2.875% Dtd 08/27/2010 Due 09/11/2020 Non-Callable Amortization of Premium	09/11/20	-424.80
Federal Natl Mtg Assn 1.50% Dtd 10/19/2015 Due 11/30/2020 Non-Callable Accretion of Discount	07/31/20	11.80
Accretion of Discount	08/31/20	11.80
Accretion of Discount	09/30/20	11.80
Federal Natl Mtg Assn 1.375% Dtd 02/05/2016 Due 02/26/2021 Non-Callable Accretion of Discount	07/31/20	21.38
Accretion of Discount	08/31/20	21.38
Accretion of Discount	09/30/20	21.38
Federal Natl Mtg Assn 1.25% Dtd 05/16/2016 Due 05/06/2021 Non-Callable Accretion of Discount	07/31/20	43.35
Accretion of Discount	08/31/20	43.35
Accretion of Discount	09/30/20	43.35
Federal Natl Mtg Assn 1.375% Dtd 10/07/2016 Due 10/07/2021 Non-Callable Accretion of Discount	07/31/20	25.07
Accretion of Discount	08/31/20	25.07
Accretion of Discount	09/30/20	25.07
Federal Natl Mtg Assn 2.00% Dtd 01/09/2017 Due 01/05/2022 Non-Callable Amortization of Premium	07/03/20	-53.10
Amortization of Premium	07/03/20	-408.90
Accretion of Discount	07/31/20	45.06
Accretion of Discount	08/31/20	45.06
Accretion of Discount	09/30/20	45.06
Federal Home Ln Mtg Corp 2.375% Dtd 01/13/2012 Due 01/13/2022 Non-Callable Amortization of Premium	07/13/20	-252.00
Amortization of Premium	07/13/20	-836.60
Indiana Univ Revs Student Fee Bds V Taxable 2.227% Dtd 10/26/2012 Due 08/01/2020 Callable Amortization of Premium	08/03/20	-70.50



WBSD - OPERATING RESERVE

Account Number:
Statement Period:

07/01/20 -
09/30/20

Non-Cash Activity		
	Date	Cost
JPMorgan Chase & Co Sr Nt 3.25% Dtd 09/24/2012 Due 09/23/2022 Non-Callable Amortization of Premium	09/23/20	-252.70
Jackson Cnty MO Reorg Sch Dist GO Sch Bldg Bds 2009c Taxable 4.90% Dtd 11/15/2009 Due 03/01/2021 Callable Amortization of Premium	09/01/20	-1,436.40
League City Tex Combi Tax and Rev Ctfs O 5.00% Dtd 07/01/2017 Due 02/15/2023 Non-Callable Amortization of Premium	08/14/20	-1,460.20
Morgan Stanley Fr 5.75% Dtd 01/25/2011 Due 01/25/2021 Callable Amortization of Premium	07/24/20	-356.85
New Hampshire Health & Ed Facs Taxable Univ Sys Issue B 2017 B Taxable 2.292% Dtd 12/06/2017 Due 07/01/2021 Non-Callable Amortization of Premium	07/01/20	-51.25
New York St Dorm Auth Revs Non Univ Rev Bds 2019b Taxable 2.839% Dtd 02/21/2019 Due 07/01/2022 Callable Amortization of Premium	07/01/20	-111.00
New York St Dorm Auth St Pers Income Tax Rev Bds 2010c Taxable 4.554% Dtd 03/11/2010 Due 02/15/2021 Callable Amortization of Premium	08/14/20	-308.50
Port Morrow Ore Transmission F Rev Bds Taxable 2.737% Dtd 08/26/2015 Due 09/01/2021 Callable Amortization of Premium	09/01/20	-1,090.00
Santa Ana Calif Fing Auth Wtr Ref Bds 5.00% Dtd 08/07/2014 Due 09/01/2022 Non-Callable Amortization of Premium	09/01/20	-580.50
Southwest Tex Indpt Sch Dist Ultd Tax Sch Bldg and RE 5.00% Dtd 07/15/2014 Due 02/01/2022 Non-Callable Amortization of Premium	08/03/20	-1,076.90



WBSD - OPERATING RESERVE

Account Number:
Statement Period:

07/01/20 -
09/30/20

Non-Cash Activity		
	Date	Cost
3M Co Fr		
2.00% Dtd 06/26/2012 Due 06/26/2022		
Non-Callable		
Accretion of Discount	07/31/20	22.27
Accretion of Discount	08/31/20	22.27
Accretion of Discount	09/30/20	22.27
Toyota Motor Credit Corp Fr		
2.90% Dtd 04/01/2020 Due 03/30/2023		
Non-Callable		
Amortization of Premium	09/30/20	-250.40
US Treasury Note		
1.125% Dtd 01/15/2011 Due 01/15/2021		
Treasury Inflation Protection Security		
Inflationary Int Adjustment 07/14/20	07/14/20	-25.00
Inflationary Int Adjustment 07/30/20	07/30/20	1.00
Inflationary Int Adjustment 08/13/20	08/13/20	290.00
Inflationary Int Adjustment 08/28/20	08/28/20	331.00
Inflationary Int Adjustment 09/15/20	09/15/20	299.00
Inflationary Int Adjustment 09/29/20	09/29/20	298.00
US Treasury Note		
0.125% Dtd 04/15/2016 Due 04/15/2021		
Treasury Inflation Protection Security		
Inflationary Int Adjustment 07/14/20	07/14/20	-20.70
Inflationary Int Adjustment 07/30/20	07/30/20	0.90
Inflationary Int Adjustment 08/13/20	08/13/20	240.30
Inflationary Int Adjustment 08/28/20	08/28/20	275.40
Inflationary Int Adjustment 09/15/20	09/15/20	248.40
Inflationary Int Adjustment 09/29/20	09/29/20	247.50
US Treasury Note		
2.00% Dtd 07/31/2013 Due 07/31/2020		
Accretion of Discount	07/31/20	101.76
US Treasury Note		
1.375% Dtd 09/15/2017 Due 09/15/2020		
Amortization of Premium	09/15/20	-365.13
US Treasury Note		
2.375% Dtd 03/15/2018 Due 03/15/2021		
Amortization of Premium	09/15/20	-775.70
US Treasury Note		
2.50% Dtd 01/31/2019 Due 01/31/2021		
Amortization of Premium	07/31/20	-830.19



WBSD - OPERATING RESERVE

Account Number:
 Statement Period:

07/01/20 -
 09/30/20

Non-Cash Activity		
	Date	Cost
Walnut Calif Energy Ctr Auth R Ref Bds 2014a 5.00% Dtd 07/23/2014 Due 01/01/2022 Non-Callable Amortization of Premium	07/01/20	-410.15
Washington St Various Purp GO Ref Bds R 5.00% Dtd 07/14/2016 Due 08/01/2022 Non-Callable Amortization of Premium	08/03/20	-975.00
Waxahachie Tex Comb Tax Rev Cfts Oblig 5.00% Dtd 09/19/2018 Due 08/01/2021 Non-Callable Amortization of Premium	08/03/20	-1,195.00
Total Non-Cash Transactions		\$ -14,460.92

SECURITY PRICES CONTAINED IN THIS STATEMENT ARE OBTAINED FROM THE MOST RELIABLE SOURCES AVAILABLE BUT ARE NOT GUARANTEED BY BANK OF THE WEST. QUOTED PRICES MAY NOT EQUAL ACTUAL PRICES BECAUSE OF SECURITY SIZE, MARKET PRICE, TERM AND DEMAND.



Electronic Funds Transfers

Preauthorized Transfers:

You may request an electronic fund transfer (EFT), such as an ACH transfer from or deposit to your account, by contacting your account Administrator. You may also preauthorize periodic EFTs by contacting your account Administrator. If you would like to know whether a preauthorized EFT has occurred, please contact your account Administrator at the phone number listed on the first page of your statement, or call 1-877-898-1003 (TTY 1-800-659-5495) between the hours of 8:00 A.M. to 5:00 P.M. Pacific Standard Time.

Error Resolution Notice:

If you think a statement or receipt is wrong or if you need more information about an EFT listed on a statement or receipt, telephone us at 1-877-898-1003 (TTY 1-800-659-5495) between the hours of 8:00 A.M. to 5:00 P.M. Pacific Standard Time, write to us at Bank of the West, 13300 Crossroads Parkway North, City of Industry, CA 91746, or e-mail us at WMGGIFSOperations@bankofthewest.com as soon as possible. We must hear from you no later than 60 days after we sent the FIRST statement on which the problem or error appeared.

1. Tell us your name and account number (if any).
2. Tell us the dollar amount of the suspected error.
3. Describe the error or the transfer you are unsure about, and explain as clearly as you can why you believe it is an error or why you need more information.

If you contact us verbally, we may require that you send us your complaint or question in writing within 10 business days. We will investigate your complaint and will correct any error promptly. If we take more than 10 business days to do this, we will credit your account for the amount you think is in error, so that you will have the use of the money during the time it takes us to complete our investigation.



WBSD - RATE STABILIZATION RESERVE

Account Number:
 Statement Period:

07/01/20 -
 09/30/20

WEST BAY SANITARY DISTRICT
 RATE STABILIZATION RESERVE
 500 LAUREL STREET
 MENLO PARK CA 94025

Fiduciary
 Chuen Ying Lee
 (408) 645-3234
Portfolio
 Michael D. Smith
 (408) 490-2079

Asset Allocation

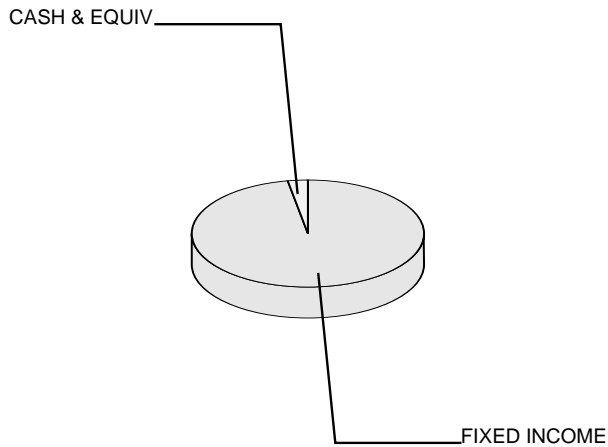

Asset Valuation

Description	Market Value	% of Account
Cash & Equiv	44,816.68	3.2%
Fixed Income	1,356,330.33	96.8%
Total Portfolio	\$ 1,401,147.01	100.0%
Accrued Income	7,113.33	
Total Valuation	\$ 1,408,260.34	

Market Reconciliation

	Current Period	Year To Date
Beginning Market Value	\$ 1,408,407.26	\$ 1,408,407.26
Income		
Interest.....	25,148.92	25,148.92
Purchased Income.....	-6,910.26	-6,910.26
Disbursements.....	-702.91	-702.91
Realized Gains/(Losses).....	0.00	0.00
Change In Accrued Income.....	-10,339.60	-10,339.60
Change In Market Appreciation/(Depreciation).....	6,062.38	6,062.38
Non-Cash Asset Changes.....	-13,405.45	-13,405.45
Ending Market Value	\$ 1,408,260.34	\$ 1,408,260.34



WBSD - RATE STABILIZATION RESERVE

Account Number:
Statement Period:

07/01/20 -
09/30/20

Asset Position As of 09/30/20

Asset Description	Units	Market Value Cost	Est. Annual Income Accruals	Current Yield
Cash Equivalents				
Bank of The West Advantage Acct	44,816.680	44,816.68 44,816.68	31.00 2.46	0.07%
Total Cash Equivalents		\$ 44,816.68 \$ 44,816.68	31.00 2.46	0.07%
Fixed Income				
Anz National Intl LTD Fr 3.40% Dtd 03/19/2019 Due 03/19/2024 Non-Callable	110,000.000	119,656.90 119,862.60	3,740.00 124.66	3.13%
Apple Inc Sr Gbl Nt 0.75% Dtd 05/11/2020 Due 05/11/2023 Callable	20,000.000	20,204.00 20,237.40	150.00 58.33	0.74%
Blackrock Inc Sr Nt 3.50% Dtd 03/18/2014 Due 03/18/2024 Callable	110,000.000	121,221.10 121,407.00	3,850.00 139.02	3.18%
Citibank NA N Y 2.85% Dtd 02/15/2018 Due 02/12/2021 Callable	60,000.000	60,444.60 60,303.00	1,710.00 232.75	2.83%
Clemson Univ S C Univ Revs Athletic Facs Rev Bds 2.00% Dtd 02/01/2012 Due 05/01/2022 Non-Callable	45,000.000	46,140.30 45,441.45	900.00 375.00	1.95%
Deere John Capital Corp Fr 3.45% Dtd 03/13/2018 Due 03/13/2025 Non-Callable	60,000.000	67,575.60 67,503.60	2,070.00 103.50	3.06%
Federal Farm Cr Bks Cons Systemwide Bds 1.90% Dtd 07/19/2017 Due 07/19/2022 Non-Callable	80,000.000	82,508.00 80,156.00	1,520.00 303.99	1.84%
Federal Farm Cr Bks Cons Systemwide Bds 1.90% Dtd 08/03/2017 Due 08/03/2022 Non-Callable	85,000.000	87,723.40 85,090.95	1,615.00 260.19	1.84%
Federal Natl Mtg Assn 1.875% Dtd 04/10/2017 Due 04/05/2022 Non-Callable	95,000.000	97,516.55 95,161.50	1,781.00 870.83	1.83%
New York Life Gbl Fdg MTN 144a Sr Sec Gbl 1.10% Dtd 05/07/2020 Due 05/05/2023 Non-Callable	110,000.000	111,853.50 112,141.70	1,210.00 483.99	1.08%



WBSD - RATE STABILIZATION RESERVE

Account Number:
Statement Period:

07/01/20 -
09/30/20

Asset Position As of 09/30/20

Asset Description	Units	Market Value Cost	Est. Annual Income Accruals	Current Yield
State Str Corp Sr Sb Nt 3.10% Dtd 05/15/2013 Due 05/15/2023 Non-Callable	110,000.000	117,258.90 117,769.30	3,410.00 1,288.22	2.91%
Toyota Motor Credit Corp Fr 2.90% Dtd 04/01/2020 Due 03/30/2023 Non-Callable	10,000.000	10,602.50 10,476.80	290.00 0.80	2.74%
Toyota Motor Credit Corp Fr 3.00% Dtd 04/01/2020 Due 04/01/2025 Callable	110,000.000	120,301.50 121,231.00	3,300.00 1,650.00	2.74%
US Treasury Note 1.625% Dtd 11/30/2015 Due 11/30/2020	150,000.000	150,375.00 149,132.09	2,437.00 819.16	1.62%
US Treasury Note 0.125% Dtd 04/15/2016 Due 04/15/2021 Treasury Inflation Protection Security	10,930.400	10,978.38 10,904.12	13.00 6.27	0.12%
US Treasury Note 1.875% Dtd 12/15/2017 Due 12/15/2020	20,000.000	20,072.40 20,104.67	375.00 110.65	1.87%
US Treasury Note 2.75% Dtd 09/15/2018 Due 09/15/2021	60,000.000	61,501.20 59,817.19	1,650.00 72.92	2.68%
US Treasury Note 2.50% Dtd 01/31/2019 Due 01/31/2021	50,000.000	50,396.50 50,209.27	1,250.00 210.59	2.48%
Total Fixed Income		\$ 1,356,330.33 \$ 1,346,949.64	31,271.00 7,110.87	2.31%
Cash				
Principal Cash		0.00 0.00	0.00	0.00%
Income Cash		0.00 0.00	0.00	0.00%
Total Cash		\$ 0.00 \$ 0.00	0.00 0.00	0.00%
Total Market Value		\$ 1,401,147.01 \$ 1,391,766.32	31,302.00 7,113.33	2.23%
Total Market Value Plus Accruals		\$ 1,408,260.34		



WBSD - RATE STABILIZATION RESERVE

Account Number:
 Statement Period:

07/01/20 -
 09/30/20

Income Activity			
	Date	Income Cash	Principal Cash
Interest Income			
Bank of The West Advantage Acct			
Int To 06/30/20	07/01/20		2.34
Int To 07/31/20	08/03/20		3.84
Int To 08/31/20	09/01/20		46.05
Anz National Intl LTD Fr			
3.40% Dtd 03/19/2019 Due 03/19/2024			
Non-Callable			
Int To 09/19/20 on 110,000	09/21/20		1,870.00
Blackrock Inc Sr Nt			
3.50% Dtd 03/18/2014 Due 03/18/2024			
Callable			
Int To 09/18/20 on 110,000	09/18/20		1,925.00
Citibank NA N Y			
2.85% Dtd 02/15/2018 Due 02/12/2021			
Callable			
Int To 08/12/20 on 60,000	08/12/20		855.00
Deere John Capital Corp Fr			
3.45% Dtd 03/13/2018 Due 03/13/2025			
Non-Callable			
Int To 09/13/20 on 60,000	09/14/20		1,035.00
Federal Farm Cr Bks Cons Systemwide			
Bds 1.90% Dtd 07/19/2017 Due			
07/19/2022 Non-Callable			
Int To 07/19/20 on 80,000	07/20/20		760.00
Federal Farm Cr Bks Cons Systemwide			
Bds 1.90% Dtd 08/03/2017 Due			
08/03/2022 Non-Callable			
Int To 08/03/20 on 85,000	08/03/20		807.50
Silicon Vy Clean Wtr Calif Was Rev			
Bds 5.00% Dtd 11/24/2015 Due			
08/01/2020 Non-Callable			
Int To 08/01/20 on 650,000	08/03/20		16,250.00
Toyota Motor Credit Corp Fr			
2.90% Dtd 04/01/2020 Due 03/30/2023			
Non-Callable			
Int 04/01/20 To 09/30/20 on 10000	09/30/20		144.19
US Treasury Note			
2.75% Dtd 09/15/2018 Due 09/15/2021			
Int To 09/15/20 on 60,000	09/15/20		825.00



WBSD - RATE STABILIZATION RESERVE

Account Number:
 Statement Period:

07/01/20 -
 09/30/20

Income Activity			
	Date	Income Cash	Principal Cash
US Treasury Note 2.50% Dtd 01/31/2019 Due 01/31/2021 Int To 07/31/20 on 50,000	07/31/20		625.00
Total Interest Income		\$ 0.00	\$ 25,148.92
Purchased Income			
Anz National Intl LTD Fr 3.40% Dtd 03/19/2019 Due 03/19/2024 Non-Callable Accrued Int To 08/26/20 Paid on Purchase of 110,000	08/26/20		-1,631.06
Blackrock Inc Sr Nt 3.50% Dtd 03/18/2014 Due 03/18/2024 Callable Accrued Int To 08/26/20 Paid on Purchase of 110,000	08/26/20		-1,689.72
Deere John Capital Corp Fr 3.45% Dtd 03/13/2018 Due 03/13/2025 Non-Callable Accrued Int To 08/26/20 Paid on Purchase of 60,000	08/27/20		-937.25
New York Life Gbl Fdg MTN 144a Sr Sec Gbl 1.10% Dtd 05/07/2020 Due 05/05/2023 Non-Callable Accrued Int To 08/26/20 Paid on Purchase of 110,000	08/26/20		-366.36
State Str Corp Sr Sb Nt 3.10% Dtd 05/15/2013 Due 05/15/2023 Non-Callable Accrued Int To 08/26/20 Paid on Purchase of 110,000	08/26/20		-956.70
Toyota Motor Credit Corp Fr 3.00% Dtd 04/01/2020 Due 04/01/2025 Callable Accrued Int To 08/26/20 Paid on Purchase of 110,000	08/26/20		-1,329.17
Total Purchased Income		\$ 0.00	\$ -6,910.26
Total Income		\$ 0.00	\$ 18,238.66



WBSD - RATE STABILIZATION RESERVE

Account Number:
 Statement Period:

07/01/20 -
 09/30/20

Disbursement Activity			
	Date	Income Cash	Principal Cash
Fees/Expenses			
Monthly Fee To 06/30/20	07/15/20		-234.10
Monthly Fee To 07/31/20	08/14/20		-233.67
Monthly Fee To 08/31/20	09/15/20		-235.14
Total Fees/Expenses		\$ 0.00	\$ -702.91
Total Disbursements		\$ 0.00	\$ -702.91

Purchase Activity			
	Date	Income Cash	Principal Cash
Bank of The West Advantage Acct Purchases (12) 07/01/20 To 09/30/20	09/30/20		-714,355.50
Anz National Intl LTD Fr 3.40% Dtd 03/19/2019 Due 03/19/2024 Non-Callable Purchased 110000 08/24/20 From BNY Mellon/Toronto Dominion Sec @ 109.128	08/26/20		-120,040.80
Blackrock Inc Sr Nt 3.50% Dtd 03/18/2014 Due 03/18/2024 Callable Purchased 110000 08/24/20 From BNY Mellon/Toronto Dominion Sec @ 110.549	08/26/20		-121,603.90
Deere John Capital Corp Fr 3.45% Dtd 03/13/2018 Due 03/13/2025 Non-Callable Purchased 60000 08/24/20 From BNY Mellon/Toronto Dominion Sec @ 112.635	08/27/20		-67,581.00
New York Life Gbl Fdg MTN 144a Sr Sec Gbl 1.10% Dtd 05/07/2020 Due 05/05/2023 Non-Callable Purchased 110000 08/24/20 From BNY Mellon/Toronto Dominion Sec @ 101.947	08/26/20		-112,141.70



WBSD - RATE STABILIZATION RESERVE

Account Number:
 Statement Period:

07/01/20 -
 09/30/20

Purchase Activity			
	Date	Income Cash	Principal Cash
State Str Corp Sr Sb Nt 3.10% Dtd 05/15/2013 Due 05/15/2023 Non-Callable Purchased 110000 08/24/20 From BNY Mellon/Toronto Dominion Sec @ 107.063	08/26/20		-117,769.30
Toyota Motor Credit Corp Fr 3.00% Dtd 04/01/2020 Due 04/01/2025 Callable Purchased 110000 08/24/20 From BNY Mellon/Toronto Dominion Sec @ 110.21	08/26/20		-121,231.00
Total Purchases		\$ 0.00	\$ -1,374,723.20

Sale Activity			
	Date	Proceeds	Realized Gain/Loss
Bank of The West Advantage Acct Sales (4) 07/01/20 To 09/30/20	09/30/20	707,187.45	
Silicon Vy Clean Wtr Calif Was Rev Bds 5.00% Dtd 11/24/2015 Due 08/01/2020 Non-Callable Recd Proceeds on Maturity of 650,000 Par Value	08/03/20	650,000.00	
Total Sales		\$ 1,357,187.45	\$ 0.00

Non-Cash Activity		
	Date	Cost
Anz National Intl LTD Fr 3.40% Dtd 03/19/2019 Due 03/19/2024 Non-Callable Amortization of Premium	09/18/20	-178.20
Blackrock Inc Sr Nt 3.50% Dtd 03/18/2014 Due 03/18/2024 Callable Amortization of Premium	09/18/20	-196.90
Citibank NA N Y 2.85% Dtd 02/15/2018 Due 02/12/2021 Callable Amortization of Premium	08/12/20	-195.00



WBSD - RATE STABILIZATION RESERVE

Account Number:
Statement Period:

07/01/20 -
09/30/20

Non-Cash Activity		
	Date	Cost
Deere John Capital Corp Fr 3.45% Dtd 03/13/2018 Due 03/13/2025 Non-Callable Amortization of Premium	09/11/20	-77.40
Federal Farm Cr Bks Cons Systemwide Bds 1.90% Dtd 07/19/2017 Due 07/19/2022 Non-Callable Amortization of Premium	07/17/20	-38.40
Federal Farm Cr Bks Cons Systemwide Bds 1.90% Dtd 08/03/2017 Due 08/03/2022 Non-Callable Amortization of Premium	08/03/20	-22.10
Silicon Vy Clean Wtr Calif Was Rev Bds 5.00% Dtd 11/24/2015 Due 08/01/2020 Non-Callable Amortization of Premium	08/03/20	-5,877.00
Amortization of Premium	08/03/20	-6,660.50
Toyota Motor Credit Corp Fr 2.90% Dtd 04/01/2020 Due 03/30/2023 Non-Callable Amortization of Premium	09/30/20	-62.60
US Treasury Note 0.125% Dtd 04/15/2016 Due 04/15/2021 Treasury Inflation Protection Security		
Inflationary Int Adjustment 07/14/20	07/14/20	-2.30
Inflationary Int Adjustment 07/30/20	07/30/20	0.10
Inflationary Int Adjustment 08/13/20	08/13/20	26.70
Inflationary Int Adjustment 08/28/20	08/28/20	30.60
Inflationary Int Adjustment 09/15/20	09/15/20	27.60
Inflationary Int Adjustment 09/29/20	09/29/20	27.50
US Treasury Note 2.50% Dtd 01/31/2019 Due 01/31/2021 Amortization of Premium	07/31/20	-207.55
Total Non-Cash Transactions		\$ -13,405.45

SECURITY PRICES CONTAINED IN THIS STATEMENT ARE OBTAINED FROM THE MOST RELIABLE SOURCES AVAILABLE BUT ARE NOT GUARANTEED BY BANK OF THE WEST. QUOTED PRICES MAY NOT EQUAL ACTUAL PRICES BECAUSE OF SECURITY SIZE, MARKET PRICE, TERM AND DEMAND.



Electronic Funds Transfers

Preauthorized Transfers:

You may request an electronic fund transfer (EFT), such as an ACH transfer from or deposit to your account, by contacting your account Administrator. You may also preauthorize periodic EFTs by contacting your account Administrator. If you would like to know whether a preauthorized EFT has occurred, please contact your account Administrator at the phone number listed on the first page of your statement, or call 1-877-898-1003 (TTY 1-800-659-5495) between the hours of 8:00 A.M. to 5:00 P.M. Pacific Standard Time.

Error Resolution Notice:

If you think a statement or receipt is wrong or if you need more information about an EFT listed on a statement or receipt, telephone us at 1-877-898-1003 (TTY 1-800-659-5495) between the hours of 8:00 A.M. to 5:00 P.M. Pacific Standard Time, write to us at Bank of the West, 13300 Crossroads Parkway North, City of Industry, CA 91746, or e-mail us at WMGGIFSOperations@bankofthewest.com as soon as possible. We must hear from you no later than 60 days after we sent the FIRST statement on which the problem or error appeared.

1. Tell us your name and account number (if any).
2. Tell us the dollar amount of the suspected error.
3. Describe the error or the transfer you are unsure about, and explain as clearly as you can why you believe it is an error or why you need more information.

If you contact us verbally, we may require that you send us your complaint or question in writing within 10 business days. We will investigate your complaint and will correct any error promptly. If we take more than 10 business days to do this, we will credit your account for the amount you think is in error, so that you will have the use of the money during the time it takes us to complete our investigation.



WBSD - CAPITAL PROJECT RESERVE

Account Number: 07/01/20 -
 Statement Period: 09/30/20

WEST BAY SANITARY DISTRICT
 500 LAUREL STREET
 MENLO PARK CA 94025

Fiduciary
 Chuen Ying Lee
 (408) 645-3234
Portfolio
 Michael D. Smith
 (408) 490-2079

Asset Allocation

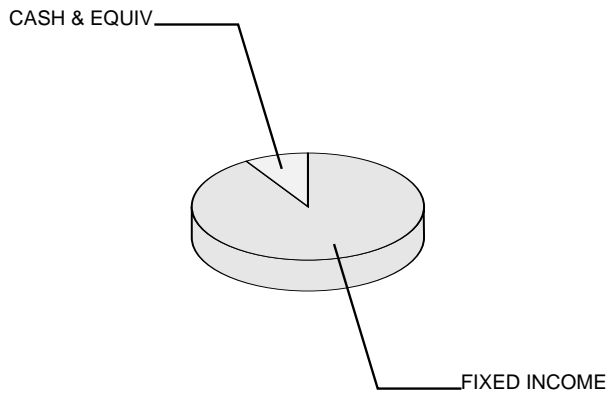

Asset Valuation

Description	Market Value	% of Account
Cash & Equiv	257,896.93	9.3%
Fixed Income	2,513,673.80	90.7%
Total Portfolio	\$ 2,771,570.73	100.0%
Accrued Income	16,117.23	
Total Valuation	\$ 2,787,687.96	

Market Reconciliation

	Current Period	Year To Date
Beginning Market Value	\$ 2,781,874.82	\$ 2,781,874.82
Income		
Interest.....	31,968.43	31,968.43
Purchased Income.....	-3,196.55	-3,196.55
Disbursements.....	-1,393.47	-1,393.47
Realized Gains/(Losses).....	0.00	0.00
Change In Accrued Income.....	-9,416.56	-9,416.56
Change In Market Appreciation/(Depreciation).....	-2,022.50	-2,022.50
Non-Cash Asset Changes.....	-10,126.21	-10,126.21
Ending Market Value	\$ 2,787,687.96	\$ 2,787,687.96



WBSD - CAPITAL PROJECT RESERVE

Account Number:
Statement Period:

07/01/20 -
09/30/20

Asset Position As of 09/30/20

Asset Description	Units	Market Value Cost	Est. Annual Income Accruals	Current Yield
Cash Equivalents				
Bank of The West Advantage Acct	257,896.930	257,896.93 257,896.93	180.00 7.90	0.07%
Total Cash Equivalents		\$ 257,896.93 \$ 257,896.93	180.00 7.90	0.07%
Fixed Income				
Anz National Intl LTD Fr 3.40% Dtd 03/19/2019 Due 03/19/2024 Non-Callable	60,000.000	65,267.40 65,379.60	2,040.00 68.00	3.13%
Apple Inc Sr Gbl Nt 0.75% Dtd 05/11/2020 Due 05/11/2023 Callable	10,000.000	10,102.00 10,118.70	75.00 29.17	0.74%
Austin Tex Indpt Sch Dist Ultd Tax Sch Bldg and RE 5.00% Dtd 04/10/2019 Due 08/01/2022 Non-Callable	100,000.000	108,843.00 107,805.00	5,000.00 833.33	4.59%
Blackrock Inc Sr Nt 3.50% Dtd 03/18/2014 Due 03/18/2024 Callable	60,000.000	66,120.60 66,222.00	2,100.00 75.83	3.18%
California St GO Bds 5.00% Dtd 03/14/2017 Due 08/01/2023 Non-Callable	60,000.000	68,103.00 66,137.40	3,000.00 499.99	4.41%
Citibank NA N Y 2.85% Dtd 02/15/2018 Due 02/12/2021 Callable	32,000.000	32,237.12 32,161.60	912.00 124.13	2.83%
Collin Cnty Tex Cmnty College GO Bds 2020a 5.00% Dtd 03/15/2020 Due 08/15/2021 Non-Callable	100,000.000	104,230.00 104,864.00	5,000.00 2,111.11	4.80%
Credit Suisse Ag New York Bran Fr 2.80% Dtd 04/09/2020 Due 04/08/2022 Non-Callable	20,000.000	20,710.60 20,728.80	560.00 267.55	2.70%
Deere John Capital Corp Fr 3.45% Dtd 03/13/2018 Due 03/13/2025 Non-Callable	50,000.000	56,313.00 56,253.00	1,725.00 86.25	3.06%
Disney Walt Co Sr Gbl Nt 1.65% Dtd 09/06/2019 Due 09/01/2022 Callable	20,000.000	20,478.00 20,377.00	330.00 27.50	1.61%



WBSD - CAPITAL PROJECT RESERVE

Account Number:
Statement Period:

07/01/20 -
09/30/20

Asset Position As of 09/30/20

Asset Description	Units	Market Value Cost	Est. Annual Income Accruals	Current Yield
East Side Un High Sch Dist Cal GO Ref Bds 3.50% Dtd 07/25/2013 Due 08/01/2021 Non-Callable	115,000.000	118,215.40 117,737.00	4,025.00 670.83	3.40%
Exxon Mobil Corp Sr Gbl Nt 1.902% Dtd 08/16/2019 Due 08/16/2022 Callable	20,000.000	20,592.40 20,580.60	380.00 47.55	1.85%
Federal Home Loan Bks Cons Bds Step Cpn Dtd 04/27/2017 Due 04/27/2022 Callable	50,000.000	51,674.00 49,887.50	1,150.00 491.94	2.23%
Federal Farm Cr Bks Cons Systemwide Bds 1.90% Dtd 07/19/2017 Due 07/19/2022 Non-Callable	60,000.000	61,881.00 60,117.00	1,140.00 228.00	1.84%
Federal Farm Cr Bks Cons Systemwide Bds 1.90% Dtd 08/03/2017 Due 08/03/2022 Non-Callable	60,000.000	61,922.40 60,064.20	1,140.00 183.66	1.84%
Federal Natl Mtg Assn 1.50% Dtd 10/19/2015 Due 11/30/2020 Non-Callable	40,000.000	40,092.80 40,060.40	600.00 201.66	1.50%
Federal Natl Mtg Assn 1.875% Dtd 11/16/2015 Due 12/28/2020 Non-Callable	100,000.000	100,408.00 100,319.00	1,875.00 484.37	1.87%
Federal Natl Mtg Assn 1.375% Dtd 02/05/2016 Due 02/26/2021 Non-Callable	60,000.000	60,304.80 59,930.45	825.00 80.20	1.37%
Federal Natl Mtg Assn 1.375% Dtd 10/07/2016 Due 10/07/2021 Non-Callable	60,000.000	60,754.80 59,795.17	825.00 398.75	1.36%
Federal Natl Mtg Assn 2.00% Dtd 01/09/2017 Due 01/05/2022 Non-Callable	120,000.000	122,892.00 120,214.80	2,400.00 573.33	1.95%
Federal Natl Mtg Assn 1.875% Dtd 04/10/2017 Due 04/05/2022 Non-Callable	60,000.000	61,589.40 60,102.00	1,125.00 550.00	1.83%
Federal Home Ln Mtg Corp 2.375% Dtd 01/13/2012 Due 01/13/2022 Non-Callable	120,000.000	123,464.40 121,024.80	2,850.00 617.50	2.31%
JPMorgan Chase & Co Sr Nt 3.25% Dtd 09/24/2012 Due 09/23/2022 Non-Callable	20,000.000	21,139.60 20,930.60	650.00 14.44	3.07%



WBSD - CAPITAL PROJECT RESERVE

Account Number:
Statement Period:

07/01/20 -
09/30/20

Asset Position As of 09/30/20

Asset Description	Units	Market Value Cost	Est. Annual Income Accruals	Current Yield
Jackson Cnty MO Reorg Sch Dist GO Sch Bldg Bds 2009c Taxable 4.90% Dtd 11/15/2009 Due 03/01/2021 Callable	135,000.000	137,068.20 137,188.35	6,615.00 551.25	4.83%
League City Tex Combi Tax and Rev Cfs O 5.00% Dtd 07/01/2017 Due 02/15/2023 Non-Callable	65,000.000	72,222.80 70,980.65	3,250.00 415.27	4.50%
Massachusetts St GO Bds 2013b 5.00% Dtd 07/02/2013 Due 08/01/2022 Non-Callable	75,000.000	81,661.50 80,824.50	3,750.00 625.00	4.59%
Michigan St GO Ref Bds 2009a Taxable 6.95% Dtd 04/14/2009 Due 11/01/2020 Non-Callable	25,000.000	25,136.50 25,645.50	1,737.00 723.95	6.91%
New York St Dorm Auth Revs Non Univ Rev Bds 2019b Taxable 2.839% Dtd 02/21/2019 Due 07/01/2022 Callable	100,000.000	103,340.00 102,210.00	2,839.00 709.74	2.75%
New York St Dorm Auth St Pers Income Tax Rev Bds 2010c Taxable 4.554% Dtd 03/11/2010 Due 02/15/2021 Callable	25,000.000	25,371.25 25,311.50	1,138.00 145.47	4.49%
San Francisco Calif City & Cnt Taxable Ref Bds 2019 A Taxable 1.814% Dtd 01/09/2020 Due 11/01/2020 Callable	50,000.000	50,060.50 50,025.00	907.00 660.09	1.81%
Southwest Tex Indpt Sch Dist Ultd Tax Sch Bldg and RE 5.00% Dtd 07/15/2014 Due 02/01/2022 Non-Callable	50,000.000	53,229.00 52,936.00	2,500.00 416.66	4.70%
Statoil Asa Sr Glbl Nt 2.75% Dtd 11/10/2014 Due 11/10/2021 Callable	44,000.000	44,996.60 44,514.36	1,210.00 473.91	2.69%
Toyota Motor Credit Corp Fr 2.90% Dtd 04/01/2020 Due 03/30/2023 Non-Callable	20,000.000	21,205.00 20,953.60	580.00 1.61	2.74%
Toyota Motor Credit Corp Fr 3.00% Dtd 04/01/2020 Due 04/01/2025 Callable	50,000.000	54,682.50 55,105.00	1,500.00 750.00	2.74%
US Treasury Note 1.625% Dtd 11/30/2015 Due 11/30/2020	30,000.000	30,075.00 30,008.48	487.00 163.83	1.62%



WBSD - CAPITAL PROJECT RESERVE

Account Number:
Statement Period:

07/01/20 -
09/30/20

Asset Position As of 09/30/20

Asset Description	Units	Market Value Cost	Est. Annual Income Accruals	Current Yield
US Treasury Note 1.125% Dtd 01/15/2011 Due 01/15/2021 Treasury Inflation Protection Security	47,370.000	47,669.38 47,117.24	532.00 112.16	1.12%
US Treasury Note 0.125% Dtd 04/15/2016 Due 04/15/2021 Treasury Inflation Protection Security	32,791.200	32,935.15 32,712.35	40.00 18.81	0.12%
US Treasury Note 1.875% Dtd 12/15/2017 Due 12/15/2020	30,000.000	30,108.60 30,157.00	562.00 165.98	1.87%
US Treasury Note 2.50% Dtd 01/31/2019 Due 01/31/2021	100,000.000	100,793.00 100,418.54	2,500.00 421.19	2.48%
University Calif Revs Gen Rev Bds 2015 A Taxable 2.909% Dtd 03/25/2015 Due 05/15/2023 Callable	65,000.000	69,130.10 68,067.35	1,890.00 714.32	2.74%
Upper Trinity Regl Wtr Dist Te Rev Ref Bds 3.00% Dtd 01/01/2012 Due 08/01/2022 Callable	75,000.000	76,653.00 76,262.25	2,250.00 375.00	2.94%
Total Fixed Income		\$ 2,513,673.80 \$ 2,491,248.29	74,014.00 16,109.33	2.94%
Cash				
Principal Cash		0.00 0.00	0.00	0.00%
Income Cash		0.00 0.00	0.00	0.00%
Total Cash		\$ 0.00 \$ 0.00	0.00 0.00	0.00%
Total Market Value		\$ 2,771,570.73 \$ 2,749,145.22	74,194.00 16,117.23	2.68%
Total Market Value Plus Accruals		\$ 2,787,687.96		



WBSD - CAPITAL PROJECT RESERVE

Account Number:
 Statement Period:

07/01/20 -
 09/30/20

Income Activity			
	Date	Income Cash	Principal Cash
Interest Income			
Bank of The West Advantage Acct			
Int To 06/30/20	07/01/20		9.92
Int To 07/31/20	08/03/20		23.03
Int To 08/31/20	09/01/20		18.81
Anz National Intl LTD Fr			
3.40% Dtd 03/19/2019 Due 03/19/2024			
Non-Callable			
Int To 09/19/20 on 60,000	09/21/20		1,020.00
Austin Tex Indpt Sch Dist Ultd Tax			
Sch Bldg and RE 5.00% Dtd 04/10/2019			
Due 08/01/2022 Non-Callable			
Int To 08/01/20 on 100,000	08/03/20		2,500.00
Blackrock Inc Sr Nt			
3.50% Dtd 03/18/2014 Due 03/18/2024			
Callable			
Int To 09/18/20 on 60,000	09/18/20		1,050.00
California St GO Bds			
5.00% Dtd 03/14/2017 Due 08/01/2023			
Non-Callable			
Int To 08/01/20 on 60,000	08/03/20		1,500.00
Citibank NA N Y			
2.85% Dtd 02/15/2018 Due 02/12/2021			
Callable			
Int To 08/12/20 on 32,000	08/12/20		456.00
Deere John Capital Corp Fr			
3.45% Dtd 03/13/2018 Due 03/13/2025			
Non-Callable			
Int To 09/13/20 on 50,000	09/14/20		862.50
Disney Walt Co Sr Gbl Nt			
1.65% Dtd 09/06/2019 Due 09/01/2022			
Callable			
Int To 09/01/20 on 20,000	09/01/20		165.00
East Side Un High Sch Dist Cal GO			
Ref Bds 3.50% Dtd 07/25/2013 Due			
08/01/2021 Non-Callable			
Int To 08/01/20 on 115,000	08/03/20		2,012.50
Exxon Mobil Corp Sr Gbl Nt			
1.902% Dtd 08/16/2019 Due 08/16/2022			
Callable			
Int To 08/16/20 on 20,000	08/17/20		190.20



WBSD - CAPITAL PROJECT RESERVE

Account Number:
 Statement Period:

2 07/01/20 -
 09/30/20

Income Activity			
	Date	Income Cash	Principal Cash
Federal Farm Cr Bks Cons Systemwide Bds 1.90% Dtd 07/19/2017 Due 07/19/2022 Non-Callable Int To 07/19/20 on 60,000	07/20/20		570.00
Federal Farm Cr Bks Cons Systemwide Bds 1.90% Dtd 08/03/2017 Due 08/03/2022 Non-Callable Int To 08/03/20 on 60,000	08/03/20		570.00
Federal Farm Cr Bks Cons Systemwide Bds 4.75% Dtd 09/21/2005 Due 09/21/2020 Non-Callable Int To 09/21/20 on 125,000	09/21/20		2,968.75
Federal Home Loan Bks Cons Bds 2.875% Dtd 08/27/2010 Due 09/11/2020 Non-Callable Int To 09/11/20 on 100,000	09/11/20		1,437.50
Federal Natl Mtg Assn 1.375% Dtd 02/05/2016 Due 02/26/2021 Non-Callable Int To 08/26/20 on 60,000	08/26/20		412.50
Federal Natl Mtg Assn 2.00% Dtd 01/09/2017 Due 01/05/2022 Non-Callable Int To 07/05/20 on 120,000	07/06/20		1,200.00
Federal Home Ln Mtg Corp 2.375% Dtd 01/13/2012 Due 01/13/2022 Non-Callable Int To 07/13/20 on 120,000	07/13/20		1,425.00
Indiana Univ Revs Student Fee Bds V Taxable 2.227% Dtd 10/26/2012 Due 08/01/2020 Callable Int To 08/01/20 on 25,000	08/03/20		278.37
JPMorgan Chase & Co Sr Nt 3.25% Dtd 09/24/2012 Due 09/23/2022 Non-Callable Int To 09/23/20 on 20,000	09/23/20		325.00
Jackson Cnty MO Reorg Sch Dist GO Sch Bldg Bds 2009c Taxable 4.90% Dtd 11/15/2009 Due 03/01/2021 Callable Int To 09/01/20 on 135,000	09/01/20		3,307.50



WBSD - CAPITAL PROJECT RESERVE

Account Number:
Statement Period:

07/01/20 -
09/30/20

Income Activity			
	Date	Income Cash	Principal Cash
League City Tex Combi Tax and Rev Cffs O 5.00% Dtd 07/01/2017 Due 02/15/2023 Non-Callable Int To 08/15/20 on 65,000	08/17/20		1,625.00
Massachusetts St GO Bds 2013b 5.00% Dtd 07/02/2013 Due 08/01/2022 Non-Callable Int To 08/01/20 on 75,000	08/03/20		1,875.00
New York St Dorm Auth Revs Non Univ Rev Bds 2019b Taxable 2.839% Dtd 02/21/2019 Due 07/01/2022 Callable Int To 07/01/20 on 100,000	07/01/20		1,419.50
New York St Dorm Auth St Pers Income Tax Rev Bds 2010c Taxable 4.554% Dtd 03/11/2010 Due 02/15/2021 Callable Int To 08/15/20 on 25,000	08/17/20		569.25
Southwest Tex Indpt Sch Dist Ultd Tax Sch Bldg and RE 5.00% Dtd 07/15/2014 Due 02/01/2022 Non-Callable Int To 08/01/20 on 50,000	08/03/20		1,250.00
Toyota Motor Credit Corp Fr 2.90% Dtd 04/01/2020 Due 03/30/2023 Non-Callable Int 04/01/20 To 09/30/20 on 20000	09/30/20		288.39
US Treasury Note 1.125% Dtd 01/15/2011 Due 01/15/2021 Treasury Inflation Protection Security Int To 07/15/20 on 46882.40	07/15/20		263.71
US Treasury Note 2.50% Dtd 01/31/2019 Due 01/31/2021 Int To 07/31/20 on 100,000	07/31/20		1,250.00
Upper Trinity Regl Wtr Dist Te Rev Ref Bds 3.00% Dtd 01/01/2012 Due 08/01/2022 Callable Int To 08/01/20 on 75,000	08/03/20		1,125.00
Total Interest Income		\$ 0.00	\$ 31,968.43



WBSD - CAPITAL PROJECT RESERVE

Account Number:
 Statement Period:

07/01/20 -
 09/30/20

Income Activity			
	Date	Income Cash	Principal Cash
Purchased Income			
Anz National Intl LTD Fr 3.40% Dtd 03/19/2019 Due 03/19/2024 Non-Callable Accrued Int To 08/26/20 Paid on Purchase of 60,000	08/26/20		-889.67
Blackrock Inc Sr Nt 3.50% Dtd 03/18/2014 Due 03/18/2024 Callable Accrued Int To 08/26/20 Paid on Purchase of 60,000	08/26/20		-921.67
Deere John Capital Corp Fr 3.45% Dtd 03/13/2018 Due 03/13/2025 Non-Callable Accrued Int To 08/26/20 Paid on Purchase of 50,000	08/26/20		-781.04
Toyota Motor Credit Corp Fr 3.00% Dtd 04/01/2020 Due 04/01/2025 Callable Accrued Int To 08/26/20 Paid on Purchase of 50,000	08/26/20		-604.17
Total Purchased Income		\$ 0.00	\$ -3,196.55
Total Income		\$ 0.00	\$ 28,771.88

Disbursement Activity			
	Date	Income Cash	Principal Cash
Fees/Expenses			
Monthly Fee To 06/30/20	07/15/20		-463.89
Monthly Fee To 07/31/20	08/14/20		-464.31
Monthly Fee To 08/31/20	09/15/20		-465.27
Total Fees/Expenses		\$ 0.00	\$ -1,393.47
Total Disbursements		\$ 0.00	\$ -1,393.47



WBSD - CAPITAL PROJECT RESERVE

Account Number:
Statement Period:

07/01/20 -
09/30/20

Purchase Activity			
	Date	Income Cash	Principal Cash
Bank of The West Advantage Acct Purchases (16) 07/01/20 To 09/30/20	09/30/20		-281,555.93
Anz National Intl LTD Fr 3.40% Dtd 03/19/2019 Due 03/19/2024 Non-Callable Purchased 60000 08/24/20 From BNY Mellon/Toronto Dominion Sec @ 109.128	08/26/20		-65,476.80
Blackrock Inc Sr Nt 3.50% Dtd 03/18/2014 Due 03/18/2024 Callable Purchased 60000 08/24/20 From BNY Mellon/Toronto Dominion Sec @ 110.549	08/26/20		-66,329.40
Deere John Capital Corp Fr 3.45% Dtd 03/13/2018 Due 03/13/2025 Non-Callable Purchased 50000 08/24/20 From BNY Mellon/Toronto Dominion Sec @ 112.635	08/26/20		-56,317.50
Toyota Motor Credit Corp Fr 3.00% Dtd 04/01/2020 Due 04/01/2025 Callable Purchased 50000 08/24/20 From BNY Mellon/Toronto Dominion Sec @ 110.21	08/26/20		-55,105.00
Total Purchases		\$ 0.00	\$ -524,784.63

Sale Activity			
	Date	Proceeds	Realized Gain/Loss
Bank of The West Advantage Acct Sales (4) 07/01/20 To 09/30/20	09/30/20	247,406.22	
Federal Farm Cr Bks Cons Systemwide Bds 4.75% Dtd 09/21/2005 Due 09/21/2020 Non-Callable Recd Proceeds on Maturity of 125,000 Par Value	09/21/20	125,000.00	
Federal Home Loan Bks Cons Bds 2.875% Dtd 08/27/2010 Due 09/11/2020 Non-Callable Recd Proceeds on Maturity of 100,000 Par Value	09/11/20	100,000.00	



WBSD - CAPITAL PROJECT RESERVE

Account Number:
 Statement Period:

07/01/20 -
 09/30/20

Sale Activity			
	Date	Proceeds	Realized Gain/Loss
Indiana Univ Revs Student Fee Bds V Taxable 2.227% Dtd 10/26/2012 Due 08/01/2020 Callable Recd Proceeds on Maturity of 25,000 Par Value	08/03/20	25,000.00	
Total Sales		\$ 497,406.22	\$ 0.00

Non-Cash Activity		
	Date	Cost
Anz National Intl LTD Fr 3.40% Dtd 03/19/2019 Due 03/19/2024 Non-Callable Amortization of Premium	09/18/20	-97.20
Austin Tex Indpt Sch Dist Ultd Tax Sch Bldg and RE 5.00% Dtd 04/10/2019 Due 08/01/2022 Non-Callable Amortization of Premium	08/03/20	-975.00
Blackrock Inc Sr Nt 3.50% Dtd 03/18/2014 Due 03/18/2024 Callable Amortization of Premium	09/18/20	-107.40
California St GO Bds 5.00% Dtd 03/14/2017 Due 08/01/2023 Non-Callable Amortization of Premium	08/03/20	-498.00
Citibank NA N Y 2.85% Dtd 02/15/2018 Due 02/12/2021 Callable Amortization of Premium	08/12/20	-104.00
Deere John Capital Corp Fr 3.45% Dtd 03/13/2018 Due 03/13/2025 Non-Callable Amortization of Premium	09/11/20	-64.50
Disney Walt Co Sr Glbl Nt 1.65% Dtd 09/06/2019 Due 09/01/2022 Callable Amortization of Premium	09/01/20	-47.40
East Side Un High Sch Dist Cal GO Ref Bds 3.50% Dtd 07/25/2013 Due 08/01/2021 Non-Callable Amortization of Premium	08/03/20	-685.40



WBSD - CAPITAL PROJECT RESERVE

Account Number:
Statement Period:

07/01/20 -
09/30/20

Non-Cash Activity		
	Date	Cost
Exxon Mobil Corp Sr Gbl Nt 1.902% Dtd 08/16/2019 Due 08/16/2022 Callable Amortization of Premium	08/14/20	-59.60
Federal Farm Cr Bks Cons Systemwide Bds 1.90% Dtd 07/19/2017 Due 07/19/2022 Non-Callable Amortization of Premium	07/17/20	-28.80
Federal Farm Cr Bks Cons Systemwide Bds 1.90% Dtd 08/03/2017 Due 08/03/2022 Non-Callable Amortization of Premium	08/03/20	-15.60
Federal Farm Cr Bks Cons Systemwide Bds 4.75% Dtd 09/21/2005 Due 09/21/2020 Non-Callable Amortization of Premium	09/21/20	-2,085.00
Federal Home Loan Bks Cons Bds 2.875% Dtd 08/27/2010 Due 09/11/2020 Non-Callable Amortization of Premium	09/11/20	-708.00
Federal Natl Mtg Assn 1.375% Dtd 02/05/2016 Due 02/26/2021 Non-Callable Accretion of Discount	07/31/20	14.25
Accretion of Discount	08/31/20	14.25
Accretion of Discount	09/30/20	14.25
Federal Natl Mtg Assn 1.375% Dtd 10/07/2016 Due 10/07/2021 Non-Callable Accretion of Discount	07/31/20	16.71
Accretion of Discount	08/31/20	16.71
Accretion of Discount	09/30/20	16.71
Federal Natl Mtg Assn 2.00% Dtd 01/09/2017 Due 01/05/2022 Non-Callable Amortization of Premium	07/03/20	-70.80
Federal Home Ln Mtg Corp 2.375% Dtd 01/13/2012 Due 01/13/2022 Non-Callable Amortization of Premium	07/13/20	-336.00



WBSD - CAPITAL PROJECT RESERVE

Account Number:
 Statement Period:

07/01/20 -
 09/30/20

Non-Cash Activity		
	Date	Cost
Indiana Univ Revs Student Fee Bds V Taxable 2.227% Dtd 10/26/2012 Due 08/01/2020 Callable Amortization of Premium	08/03/20	-70.50
JPMorgan Chase & Co Sr Nt 3.25% Dtd 09/24/2012 Due 09/23/2022 Non-Callable Amortization of Premium	09/23/20	-144.40
Jackson Cnty MO Reorg Sch Dist GO Sch Bldg Bds 2009c Taxable 4.90% Dtd 11/15/2009 Due 03/01/2021 Callable Amortization of Premium	09/01/20	-1,615.95
League City Tex Combi Tax and Rev Cfs O 5.00% Dtd 07/01/2017 Due 02/15/2023 Non-Callable Amortization of Premium	08/14/20	-677.95
Massachusetts St GO Bds 2013b 5.00% Dtd 07/02/2013 Due 08/01/2022 Non-Callable Amortization of Premium	08/03/20	-725.25
New York St Dorm Auth Revs Non Univ Rev Bds 2019b Taxable 2.839% Dtd 02/21/2019 Due 07/01/2022 Callable Amortization of Premium	07/01/20	-222.00
New York St Dorm Auth St Pers Income Tax Rev Bds 2010c Taxable 4.554% Dtd 03/11/2010 Due 02/15/2021 Callable Amortization of Premium	08/14/20	-308.50
Southwest Tex Indpt Sch Dist Ultd Tax Sch Bldg and RE 5.00% Dtd 07/15/2014 Due 02/01/2022 Non-Callable Amortization of Premium	08/03/20	-489.50
Toyota Motor Credit Corp Fr 2.90% Dtd 04/01/2020 Due 03/30/2023 Non-Callable Amortization of Premium	09/30/20	-125.20
US Treasury Note 1.125% Dtd 01/15/2011 Due 01/15/2021 Treasury Inflation Protection Security Inflationary Int Adjustment 07/14/20	07/14/20	-10.00
Inflationary Int Adjustment 07/30/20	07/30/20	0.40



WBSD - CAPITAL PROJECT RESERVE

Account Number:
 Statement Period:

07/01/20 -
 09/30/20

Non-Cash Activity

	Date	Cost
Inflationary Int Adjustment 08/13/20	08/13/20	116.00
Inflationary Int Adjustment 08/28/20	08/28/20	132.40
Inflationary Int Adjustment 09/15/20	09/15/20	119.60
Inflationary Int Adjustment 09/29/20	09/29/20	119.20
US Treasury Note		
0.125% Dtd 04/15/2016 Due 04/15/2021		
Treasury Inflation Protection Security		
Inflationary Int Adjustment 07/14/20	07/14/20	-6.90
Inflationary Int Adjustment 07/30/20	07/30/20	0.30
Inflationary Int Adjustment 08/13/20	08/13/20	80.10
Inflationary Int Adjustment 08/28/20	08/28/20	91.80
Inflationary Int Adjustment 09/15/20	09/15/20	82.80
Inflationary Int Adjustment 09/29/20	09/29/20	82.50
US Treasury Note		
2.50% Dtd 01/31/2019 Due 01/31/2021		
Amortization of Premium	07/31/20	-415.09
Upper Trinity Regl Wtr Dist Te Rev		
Ref Bds 3.00% Dtd 01/01/2012 Due		
08/01/2022 Callable		
Amortization of Premium	08/03/20	-350.25
Total Non-Cash Transactions		\$ -10,126.21

SECURITY PRICES CONTAINED IN THIS STATEMENT ARE OBTAINED FROM THE MOST RELIABLE SOURCES AVAILABLE BUT ARE NOT GUARANTEED BY BANK OF THE WEST. QUOTED PRICES MAY NOT EQUAL ACTUAL PRICES BECAUSE OF SECURITY SIZE, MARKET PRICE, TERM AND DEMAND.



Electronic Funds Transfers

Preauthorized Transfers:

You may request an electronic fund transfer (EFT), such as an ACH transfer from or deposit to your account, by contacting your account Administrator. You may also preauthorize periodic EFTs by contacting your account Administrator. If you would like to know whether a preauthorized EFT has occurred, please contact your account Administrator at the phone number listed on the first page of your statement, or call 1-877-898-1003 (TTY 1-800-659-5495) between the hours of 8:00 A.M. to 5:00 P.M. Pacific Standard Time.

Error Resolution Notice:

If you think a statement or receipt is wrong or if you need more information about an EFT listed on a statement or receipt, telephone us at 1-877-898-1003 (TTY 1-800-659-5495) between the hours of 8:00 A.M. to 5:00 P.M. Pacific Standard Time, write to us at Bank of the West, 13300 Crossroads Parkway North, City of Industry, CA 91746, or e-mail us at WMGGIFSOperations@bankofthewest.com as soon as possible. We must hear from you no later than 60 days after we sent the FIRST statement on which the problem or error appeared.

1. Tell us your name and account number (if any).
2. Tell us the dollar amount of the suspected error.
3. Describe the error or the transfer you are unsure about, and explain as clearly as you can why you believe it is an error or why you need more information.

If you contact us verbally, we may require that you send us your complaint or question in writing within 10 business days. We will investigate your complaint and will correct any error promptly. If we take more than 10 business days to do this, we will credit your account for the amount you think is in error, so that you will have the use of the money during the time it takes us to complete our investigation.



WBSD - RECYCLED WATER CASH FLOW

Account Number:
 Statement Period:

07/01/20 -
 09/30/20

WEST BAY SANITARY DISTRICT
 RECYCLED WATER CASH FLOW
 500 LAUREL STREET
 MENLO PARK CA 94025

Fiduciary
 Chuen Ying Lee
 (408) 645-3234
Portfolio
 Michael D. Smith
 (408) 490-2079

Asset Allocation

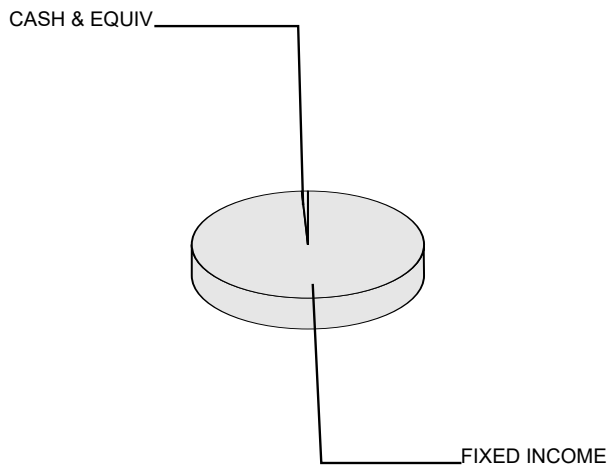

Asset Valuation

Description	Market Value	% of Account
Cash & Equiv	1,927.31	0.9%
Fixed Income	225,461.90	99.2%
Total Portfolio	\$ 227,389.21	100.0%
Accrued Income	1,593.65	
Total Valuation	\$ 228,982.86	

Market Reconciliation

	Current Period	Year To Date
Beginning Market Value	\$ 228,463.67	\$ 228,463.67
Income		
Interest.....	1,324.04	1,324.04
Purchased Income.....	-603.78	-603.78
Disbursements.....	-114.82	-114.82
Realized Gains/(Losses).....	0.00	0.00
Change In Accrued Income.....	410.66	410.66
Change In Market Appreciation/(Depreciation).....	-606.86	-606.86
Non-Cash Asset Changes.....	109.95	109.95
Ending Market Value	\$ 228,982.86	\$ 228,982.86



WBSD - RECYCLED WATER CASH FLOW

Account Number:
Statement Period:

07/01/20 -
09/30/20

Asset Position As of 09/30/20

Asset Description	Units	Market Value Cost	Est. Annual Income Accruals	Current Yield
Cash Equivalents				
Bank of The West Advantage Acct	1,927.310	1,927.31 1,927.31	1.00 0.09	0.07%
Total Cash Equivalents		\$ 1,927.31 \$ 1,927.31	1.00 0.09	0.07%
Fixed Income				
Anz National Intl LTD Fr 3.40% Dtd 03/19/2019 Due 03/19/2024 Non-Callable	20,000.000	21,755.80 21,793.20	680.00 22.66	3.13%
Blackrock Inc Sr Nt 3.50% Dtd 03/18/2014 Due 03/18/2024 Callable	20,000.000	22,040.20 22,074.00	700.00 25.27	3.18%
New York N Y GO Bds Subser Taxable 4.669% Dtd 10/15/2009 Due 10/01/2022 Callable	35,000.000	37,706.20 37,231.95	1,634.00 817.07	4.33%
San Francisco Calif City & Cnt Taxable Ref Bds 2019 A Taxable 1.814% Dtd 01/09/2020 Due 11/01/2020 Callable	25,000.000	25,030.25 25,012.50	453.00 330.04	1.81%
US Treasury Note 0.125% Dtd 04/15/2016 Due 04/15/2021 Treasury Inflation Protection Security	38,256.400	38,424.35 38,164.40	47.00 21.95	0.12%
US Treasury Note 1.875% Dtd 12/15/2017 Due 12/15/2020	30,000.000	30,108.60 30,157.00	562.00 165.98	1.87%
US Treasury Note 2.50% Dtd 01/31/2019 Due 01/31/2021	50,000.000	50,396.50 50,209.27	1,250.00 210.59	2.48%
Total Fixed Income		\$ 225,461.90 \$ 224,642.32	5,326.00 1,593.56	2.36%
Cash				
Principal Cash		0.00 0.00	0.00	0.00%
Income Cash		0.00 0.00	0.00	0.00%



WBSD - RECYCLED WATER CASH FLOW

Account Number:
 Statement Period:

07/01/20 -
 09/30/20

Asset Position As of 09/30/20

Asset Description	Units	Market Value Cost	Est. Annual Income Accruals	Current Yield
Total Cash		\$ 0.00 \$ 0.00	0.00 0.00	0.00%
Total Market Value		\$ 227,389.21 \$ 226,569.63	5,327.00 1,593.65	2.34%
Total Market Value Plus Accruals		\$ 228,982.86		

Income Activity

	Date	Income Cash	Principal Cash
Interest Income			
Bank of The West Advantage Acct			
Int To 06/30/20	07/01/20		1.21
Int To 07/31/20	08/03/20		4.59
Int To 08/31/20	09/01/20		3.24
Anz National Intl LTD Fr 3.40% Dtd 03/19/2019 Due 03/19/2024 Non-Callable			
Int To 09/19/20 on 20,000	09/21/20		340.00
Blackrock Inc Sr Nt 3.50% Dtd 03/18/2014 Due 03/18/2024 Callable			
Int To 09/18/20 on 20,000	09/18/20		350.00
US Treasury Note 2.50% Dtd 01/31/2019 Due 01/31/2021			
Int To 07/31/20 on 50,000	07/31/20		625.00
Total Interest Income		\$ 0.00	\$ 1,324.04
Purchased Income			
Anz National Intl LTD Fr 3.40% Dtd 03/19/2019 Due 03/19/2024 Non-Callable			
Accrued Int To 08/26/20 Paid on Purchase of 20,000	08/26/20		-296.56



WBSD - RECYCLED WATER CASH FLOW

Account Number:
Statement Period:

Income Activity			
	Date	Income Cash	Principal Cash
Blackrock Inc Sr Nt 3.50% Dtd 03/18/2014 Due 03/18/2024 Callable Accrued Int To 08/26/20 Paid on Purchase of 20,000	08/26/20		-307.22
Total Purchased Income		\$ 0.00	\$ -603.78
Total Income		\$ 0.00	\$ 720.26

Disbursement Activity			
	Date	Income Cash	Principal Cash
Fees/Expenses			
Monthly Fee To 06/30/20	07/15/20		-38.25
Monthly Fee To 07/31/20	08/14/20		-38.35
Monthly Fee To 08/31/20	09/15/20		-38.22
Total Fees/Expenses		\$ 0.00	\$ -114.82
Total Disbursements		\$ 0.00	\$ -114.82

Purchase Activity			
	Date	Income Cash	Principal Cash
Bank of The West Advantage Acct Purchases (6) 07/01/20 To 09/30/20	09/30/20		-1,324.04
Anz National Intl LTD Fr 3.40% Dtd 03/19/2019 Due 03/19/2024 Non-Callable Purchased 20000 08/24/20 From BNY Mellon/Toronto Dominion Sec @ 109.128	08/26/20		-21,825.60
Blackrock Inc Sr Nt 3.50% Dtd 03/18/2014 Due 03/18/2024 Callable Purchased 20000 08/24/20 From BNY Mellon/Toronto Dominion Sec @ 110.549	08/26/20		-22,109.80
Total Purchases		\$ 0.00	\$ -45,259.44



WBSD - RECYCLED WATER CASH FLOW

Account Number:
 Statement Period:

07/01/20 -
 09/30/20

Sale Activity			
	Date	Proceeds	Realized Gain/Loss
Bank of The West Advantage Acct Sales (4) 07/01/20 To 09/30/20	09/30/20	44,654.00	
Total Sales		\$ 44,654.00	\$ 0.00

Non-Cash Activity		
	Date	Cost
Anz National Intl LTD Fr 3.40% Dtd 03/19/2019 Due 03/19/2024 Non-Callable Amortization of Premium	09/18/20	-32.40
Blackrock Inc Sr Nt 3.50% Dtd 03/18/2014 Due 03/18/2024 Callable Amortization of Premium	09/18/20	-35.80
US Treasury Note 0.125% Dtd 04/15/2016 Due 04/15/2021 Treasury Inflation Protection Security		
Inflationary Int Adjustment 07/14/20	07/14/20	-8.05
Inflationary Int Adjustment 07/30/20	07/30/20	0.35
Inflationary Int Adjustment 08/13/20	08/13/20	93.45
Inflationary Int Adjustment 08/28/20	08/28/20	107.10
Inflationary Int Adjustment 09/15/20	09/15/20	96.60
Inflationary Int Adjustment 09/29/20	09/29/20	96.25
US Treasury Note 2.50% Dtd 01/31/2019 Due 01/31/2021 Amortization of Premium	07/31/20	-207.55
Total Non-Cash Transactions		\$ 109.95

SECURITY PRICES CONTAINED IN THIS STATEMENT ARE OBTAINED FROM THE MOST RELIABLE SOURCES AVAILABLE BUT ARE NOT GUARANTEED BY BANK OF THE WEST. QUOTED PRICES MAY NOT EQUAL ACTUAL PRICES BECAUSE OF SECURITY SIZE, MARKET PRICE, TERM AND DEMAND.



Electronic Funds Transfers

Preauthorized Transfers:

You may request an electronic fund transfer (EFT), such as an ACH transfer from or deposit to your account, by contacting your account Administrator. You may also preauthorize periodic EFTs by contacting your account Administrator. If you would like to know whether a preauthorized EFT has occurred, please contact your account Administrator at the phone number listed on the first page of your statement, or call 1-877-898-1003 (TTY 1-800-659-5495) between the hours of 8:00 A.M. to 5:00 P.M. Pacific Standard Time.

Error Resolution Notice:

If you think a statement or receipt is wrong or if you need more information about an EFT listed on a statement or receipt, telephone us at 1-877-898-1003 (TTY 1-800-659-5495) between the hours of 8:00 A.M. to 5:00 P.M. Pacific Standard Time, write to us at Bank of the West, 13300 Crossroads Parkway North, City of Industry, CA 91746, or e-mail us at WMGGIFSOoperations@bankofthewest.com as soon as possible. We must hear from you no later than 60 days after we sent the FIRST statement on which the problem or error appeared.

1. Tell us your name and account number (if any).
2. Tell us the dollar amount of the suspected error.
3. Describe the error or the transfer you are unsure about, and explain as clearly as you can why you believe it is an error or why you need more information.

If you contact us verbally, we may require that you send us your complaint or question in writing within 10 business days. We will investigate your complaint and will correct any error promptly. If we take more than 10 business days to do this, we will credit your account for the amount you think is in error, so that you will have the use of the money during the time it takes us to complete our investigation.



WBSD - RECYCLED WATER SRF RESERVE

Account Number:
 Statement Period:

07/01/20 -
 09/30/20

WEST BAY SANITARY DISTRICT
 RECYCLED WATER SRF RESERVE
 500 LAUREL STREET
 MENLO PARK CA 94025

Fiduciary
 Chuen Ying Lee
 (408) 645-3234
Portfolio
 Michael D. Smith
 (408) 490-2079

Asset Allocation

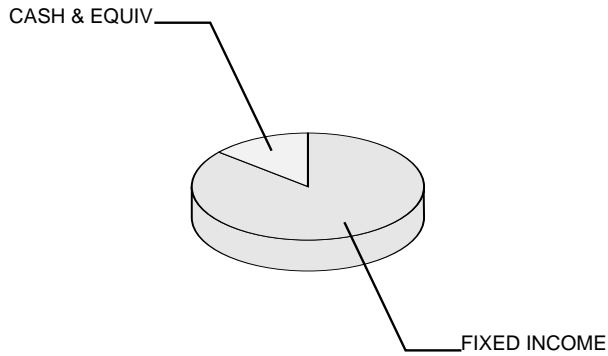

Asset Valuation

Description	Market Value	% of Account
Cash & Equiv	217,578.61	14.2%
Fixed Income	1,310,802.86	85.8%
Total Portfolio	\$ 1,528,381.47	100.0%
Accrued Income	7,519.21	
Total Valuation	\$ 1,535,900.68	

Market Reconciliation

	Current Period	Year To Date
Beginning Market Value	\$ 1,530,349.55	\$ 1,530,349.55
Income		
Interest.....	12,693.57	12,693.57
Purchased Income.....	-2,340.56	-2,340.56
Disbursements.....	-769.66	-769.66
Realized Gains/(Losses).....	0.00	0.00
Change In Accrued Income.....	-1,398.21	-1,398.21
Change In Market Appreciation/(Depreciation).....	-76.93	-76.93
Non-Cash Asset Changes.....	-2,557.08	-2,557.08
Ending Market Value	\$ 1,535,900.68	\$ 1,535,900.68



WBSD - RECYCLED WATER SRF RESERVE

Account Number:
Statement Period:

2 07/01/20 -
09/30/20

Asset Position As of 09/30/20

Asset Description	Units	Market Value Cost	Est. Annual Income Accruals	Current Yield
Cash Equivalents				
Bank of The West Advantage Acct	217,578.610	217,578.61 217,578.61	152.00 1.98	0.07%
Total Cash Equivalents		\$ 217,578.61 \$ 217,578.61	152.00 1.98	0.07%
Fixed Income				
Anz National Intl LTD Fr 3.40% Dtd 03/19/2019 Due 03/19/2024 Non-Callable	50,000.000	54,389.50 54,483.00	1,700.00 56.66	3.13%
American Express Co Sr Gbl 2.50% Dtd 07/30/2019 Due 07/30/2024 Callable	100,000.000	106,433.00 105,596.00	2,500.00 423.61	2.35%
Apple Inc Sr Gbl Nt 0.75% Dtd 05/11/2020 Due 05/11/2023 Callable	40,000.000	40,408.00 40,474.80	300.00 116.65	0.74%
Autozone Inc Sr Gbl 2.50% Dtd 04/29/2015 Due 04/15/2021 Callable	20,000.000	20,198.80 20,268.40	500.00 230.55	2.48%
Blackrock Inc Sr Nt 3.50% Dtd 03/18/2014 Due 03/18/2024 Callable	50,000.000	55,100.50 55,185.00	1,750.00 63.19	3.18%
Bristol Myers Squibb Co Sr Gbl 144a 2.60% Dtd 05/16/2019 Due 05/16/2022 Callable	70,000.000	72,621.50 72,794.40	1,820.00 682.49	2.51%
California Health Facs Fing Au Bds 2019 A 5.00% Dtd 08/06/2019 Due 11/01/2022 Non-Callable	25,000.000	27,356.50 27,074.75	1,250.00 520.83	4.57%
Credit Suisse Ag New York Bran Fr 2.80% Dtd 04/09/2020 Due 04/08/2022 Non-Callable	30,000.000	31,065.90 31,093.20	840.00 401.32	2.70%
Deere John Capital Corp Fr 3.45% Dtd 03/13/2018 Due 03/13/2025 Non-Callable	30,000.000	33,787.80 33,751.80	1,035.00 51.75	3.06%
Disney Walt Co Sr Gbl Nt 1.65% Dtd 09/06/2019 Due 09/01/2022 Callable	30,000.000	30,717.00 30,565.50	495.00 41.25	1.61%



WBSD - RECYCLED WATER SRF RESERVE

Account Number:
Statement Period:

07/01/20 -
09/30/20

Asset Position As of 09/30/20

Asset Description	Units	Market Value Cost	Est. Annual Income Accruals	Current Yield
Exxon Mobil Corp Sr Gbl Nt 1.902% Dtd 08/16/2019 Due 08/16/2022 Callable	30,000.000	30,888.60 30,870.90	570.00 71.32	1.85%
Federal Farm Cr Bks Cons Systemwide Bds 3.65% Dtd 12/21/2010 Due 12/21/2020 Non-Callable	96,000.000	96,762.24 96,519.36	3,504.00 973.33	3.62%
Huntington Bancshares Inc Sr Gbl Nt 2.625% Dtd 08/06/2019 Due 08/06/2024 Callable	100,000.000	106,510.00 105,758.00	2,625.00 401.04	2.46%
Intel Corp Sr Gbl 3.40% Dtd 03/25/2020 Due 03/25/2025 Callable	80,000.000	89,633.60 89,427.20	2,720.00 45.33	3.03%
JPMorgan Chase & Co Sr Nt 3.25% Dtd 09/24/2012 Due 09/23/2022 Non-Callable	30,000.000	31,709.40 31,395.90	975.00 21.66	3.07%
Morgan Stanley Fr 5.75% Dtd 01/25/2011 Due 01/25/2021 Callable	20,000.000	20,341.80 20,520.60	1,150.00 210.83	5.65%
Qualcomm Inc Fr 2.60% Dtd 05/26/2017 Due 01/30/2023 Callable	90,000.000	94,313.70 94,376.70	2,340.00 396.50	2.48%
San Francisco Calif City & Cnt Taxable Ref Bds 2019 A Taxable 1.814% Dtd 01/09/2020 Due 11/01/2020 Callable	25,000.000	25,030.25 25,012.50	453.00 330.04	1.81%
Toyota Motor Credit Corp Fr 3.00% Dtd 04/01/2020 Due 04/01/2025 Callable	110,000.000	120,301.50 120,953.40	3,300.00 1,650.00	2.74%
US Treasury Note 0.125% Dtd 04/15/2016 Due 04/15/2021 Treasury Inflation Protection Security	21,860.800	21,956.77 21,808.23	27.00 12.54	0.12%
US Treasury Note 1.875% Dtd 12/15/2017 Due 12/15/2020	100,000.000	100,362.00 100,523.34	1,875.00 553.27	1.87%
US Treasury Note 2.375% Dtd 03/15/2018 Due 03/15/2021	50,000.000	50,518.00 50,389.42	1,187.00 52.48	2.35%
US Treasury Note 2.50% Dtd 01/31/2019 Due 01/31/2021	50,000.000	50,396.50 50,209.27	1,250.00 210.59	2.48%



WBSD - RECYCLED WATER SRF RESERVE

Account Number:
 Statement Period:

07/01/20 -
 09/30/20

Asset Position As of 09/30/20

Asset Description	Units	Market Value Cost	Est. Annual Income Accruals	Current Yield
Total Fixed Income		\$ 1,310,802.86 \$ 1,309,051.67	34,166.00 7,517.23	2.61%
Cash				
Principal Cash		0.00 0.00	0.00	0.00%
Income Cash		0.00 0.00	0.00	0.00%
Total Cash		\$ 0.00 \$ 0.00	0.00 0.00	0.00%
Total Market Value		\$ 1,528,381.47 \$ 1,526,630.28	34,318.00 7,519.21	2.25%
Total Market Value Plus Accruals		\$ 1,535,900.68		

Income Activity

	Date	Income Cash	Principal Cash
Interest Income			
Bank of The West Advantage Acct			
Int To 06/30/20	07/01/20		45.46
Int To 07/31/20	08/03/20		17.72
Int To 08/31/20	09/01/20		12.59
Anz National Intl LTD Fr 3.40% Dtd 03/19/2019 Due 03/19/2024 Non-Callable			
Int To 09/19/20 on 50,000	09/21/20		850.00
American Express Co Sr Gbl 2.50% Dtd 07/30/2019 Due 07/30/2024 Callable			
Int To 07/30/20 on 100,000	07/30/20		1,250.00
Blackrock Inc Sr Nt 3.50% Dtd 03/18/2014 Due 03/18/2024 Callable			
Int To 09/18/20 on 50,000	09/18/20		875.00
Deere John Capital Corp Fr 3.45% Dtd 03/13/2018 Due 03/13/2025 Non-Callable			
Int To 09/13/20 on 30,000	09/14/20		517.50



WBSD - RECYCLED WATER SRF RESERVE

Account Number:
 Statement Period:

07/01/20 -
 09/30/20

Income Activity			
	Date	Income Cash	Principal Cash
Disney Walt Co Sr Gbl Nt 1.65% Dtd 09/06/2019 Due 09/01/2022 Callable Int To 09/01/20 on 30,000	09/01/20		247.50
Exxon Mobil Corp Sr Gbl Nt 1.902% Dtd 08/16/2019 Due 08/16/2022 Callable Int To 08/16/20 on 30,000	08/17/20		285.30
Huntington Bancshares Inc Sr Gbl Nt 2.625% Dtd 08/06/2019 Due 08/06/2024 Callable Int To 08/06/20 on 100,000	08/06/20		1,312.50
Intel Corp Sr Gbl 3.40% Dtd 03/25/2020 Due 03/25/2025 Callable Int 03/25/20 To 09/25/20 on 80000	09/25/20		1,360.00
JPMorgan Chase & Co Sr Nt 3.25% Dtd 09/24/2012 Due 09/23/2022 Non-Callable Int To 09/23/20 on 30,000	09/23/20		487.50
Morgan Stanley Fr 5.75% Dtd 01/25/2011 Due 01/25/2021 Callable Int To 07/25/20 on 20,000	07/27/20		575.00
Qualcomm Inc Fr 2.60% Dtd 05/26/2017 Due 01/30/2023 Callable Int To 07/30/20 on 90,000	07/30/20		1,170.00
US Treasury Note 2.00% Dtd 09/30/2013 Due 09/30/2020 Int To 09/30/20 on 20,000	09/30/20		200.00
US Treasury Note 1.375% Dtd 09/15/2017 Due 09/15/2020 Int To 09/15/20 on 50,000	09/15/20		343.75
US Treasury Note 2.375% Dtd 03/15/2018 Due 03/15/2021 Int To 09/15/20 on 50,000	09/15/20		593.75
US Treasury Note 2.75% Dtd 09/30/2018 Due 09/30/2020 Int To 09/30/20 on 140,000	09/30/20		1,925.00



WBSD - RECYCLED WATER SRF RESERVE

Account Number:
 Statement Period:

07/01/20 -
 09/30/20

Income Activity			
	Date	Income Cash	Principal Cash
US Treasury Note 2.50% Dtd 01/31/2019 Due 01/31/2021 Int To 07/31/20 on 50,000	07/31/20		625.00
Total Interest Income		\$ 0.00	\$ 12,693.57
Purchased Income			
Anz National Intl LTD Fr 3.40% Dtd 03/19/2019 Due 03/19/2024 Non-Callable Accrued Int To 08/26/20 Paid on Purchase of 50,000	08/26/20		-741.37
Blackrock Inc Sr Nt 3.50% Dtd 03/18/2014 Due 03/18/2024 Callable Accrued Int To 08/26/20 Paid on Purchase of 50,000	08/26/20		-768.06
Deere John Capital Corp Fr 3.45% Dtd 03/13/2018 Due 03/13/2025 Non-Callable Accrued Int To 08/26/20 Paid on Purchase of 30,000	08/26/20		-468.63
Toyota Motor Credit Corp Fr 3.00% Dtd 04/01/2020 Due 04/01/2025 Callable Accrued Int To 08/26/20 Paid on Purchase of 30,000	08/26/20		-362.50
Total Purchased Income		\$ 0.00	\$ -2,340.56
Total Income		\$ 0.00	\$ 10,353.01

Disbursement Activity			
	Date	Income Cash	Principal Cash
Fees/Expenses			
Monthly Fee To 06/30/20	07/15/20		-256.05
Monthly Fee To 07/31/20	08/14/20		-257.07
Monthly Fee To 08/31/20	09/15/20		-256.54
Total Fees/Expenses		\$ 0.00	\$ -769.66
Total Disbursements		\$ 0.00	\$ -769.66



WBSD - RECYCLED WATER SRF RESERVE

Account Number:
 Statement Period:

07/01/20 -
 09/30/20

Purchase Activity			
	Date	Income Cash	Principal Cash
Bank of The West Advantage Acct Purchases (15) 07/01/20 To 09/30/20	09/30/20		-222,693.57
Anz National Intl LTD Fr 3.40% Dtd 03/19/2019 Due 03/19/2024 Non-Callable Purchased 50000 08/24/20 From BNY Mellon/Toronto Dominion Sec @ 109.128	08/26/20		-54,564.00
Blackrock Inc Sr Nt 3.50% Dtd 03/18/2014 Due 03/18/2024 Callable Purchased 50000 08/24/20 From BNY Mellon/Toronto Dominion Sec @ 110.549	08/26/20		-55,274.50
Deere John Capital Corp Fr 3.45% Dtd 03/13/2018 Due 03/13/2025 Non-Callable Purchased 30000 08/24/20 From BNY Mellon/Toronto Dominion Sec @ 112.635	08/26/20		-33,790.50
Toyota Motor Credit Corp Fr 3.00% Dtd 04/01/2020 Due 04/01/2025 Callable Purchased 30000 08/24/20 From BNY Mellon/Toronto Dominion Sec @ 110.21	08/26/20		-33,063.00
Total Purchases		\$ 0.00	\$ -399,385.57

Sale Activity			
	Date	Proceeds	Realized Gain/Loss
Bank of The West Advantage Acct Sales (4) 07/01/20 To 09/30/20	09/30/20	179,802.22	
US Treasury Note 2.00% Dtd 09/30/2013 Due 09/30/2020 Recd Proceeds on Maturity of 20,000 Par Value	09/30/20	20,000.00	
US Treasury Note 1.375% Dtd 09/15/2017 Due 09/15/2020 Recd Proceeds on Maturity of 50,000 Par Value	09/15/20	50,000.00	



WBSD - RECYCLED WATER SRF RESERVE

Account Number:
Statement Period:

07/01/20 -
09/30/20

Sale Activity			
	Date	Proceeds	Realized Gain/Loss
US Treasury Note 2.75% Dtd 09/30/2018 Due 09/30/2020 Recd Proceeds on Maturity of 140,000 Par Value	09/30/20	140,000.00	
Total Sales		\$ 389,802.22	\$ 0.00

Non-Cash Activity		
	Date	Cost
Anz National Intl LTD Fr 3.40% Dtd 03/19/2019 Due 03/19/2024 Non-Callable Amortization of Premium	09/18/20	-81.00
American Express Co Sr Gbl 2.50% Dtd 07/30/2019 Due 07/30/2024 Callable Amortization of Premium	07/30/20	-156.00
Blackrock Inc Sr Nt 3.50% Dtd 03/18/2014 Due 03/18/2024 Callable Amortization of Premium	09/18/20	-89.50
Deere John Capital Corp Fr 3.45% Dtd 03/13/2018 Due 03/13/2025 Non-Callable Amortization of Premium	09/11/20	-38.70
Disney Walt Co Sr Gbl Nt 1.65% Dtd 09/06/2019 Due 09/01/2022 Callable Amortization of Premium	09/01/20	-71.10
Exxon Mobil Corp Sr Gbl Nt 1.902% Dtd 08/16/2019 Due 08/16/2022 Callable Amortization of Premium	08/14/20	-89.40
Huntington Bancshares Inc Sr Gbl Nt 2.625% Dtd 08/06/2019 Due 08/06/2024 Callable Amortization of Premium	08/06/20	-184.00
Intel Corp Sr Gbl 3.40% Dtd 03/25/2020 Due 03/25/2025 Callable Amortization of Premium	09/25/20	-549.60



WBSD - RECYCLED WATER SRF RESERVE

Account Number:
Statement Period:

6 07/01/20 -
09/30/20

Non-Cash Activity		
	Date	Cost
JPMorgan Chase & Co Sr Nt 3.25% Dtd 09/24/2012 Due 09/23/2022 Non-Callable Amortization of Premium	09/23/20	-216.60
Morgan Stanley Fr 5.75% Dtd 01/25/2011 Due 01/25/2021 Callable Amortization of Premium	07/24/20	-158.60
Qualcomm Inc Fr 2.60% Dtd 05/26/2017 Due 01/30/2023 Callable Amortization of Premium	07/30/20	-198.00
US Treasury Note 0.125% Dtd 04/15/2016 Due 04/15/2021 Treasury Inflation Protection Security		
Inflationary Int Adjustment 07/14/20	07/14/20	-4.60
Inflationary Int Adjustment 07/30/20	07/30/20	0.20
Inflationary Int Adjustment 08/13/20	08/13/20	53.40
Inflationary Int Adjustment 08/28/20	08/28/20	61.20
Inflationary Int Adjustment 09/15/20	09/15/20	55.20
Inflationary Int Adjustment 09/29/20	09/29/20	55.00
US Treasury Note 2.00% Dtd 09/30/2013 Due 09/30/2020 Accretion of Discount	09/30/20	41.95
US Treasury Note 1.375% Dtd 09/15/2017 Due 09/15/2020 Amortization of Premium	09/15/20	-121.71
US Treasury Note 2.375% Dtd 03/15/2018 Due 03/15/2021 Amortization of Premium	09/15/20	-387.85
US Treasury Note 2.75% Dtd 09/30/2018 Due 09/30/2020 Amortization of Premium	09/30/20	-269.82
US Treasury Note 2.50% Dtd 01/31/2019 Due 01/31/2021 Amortization of Premium	07/31/20	-207.55
Total Non-Cash Transactions		\$ -2,557.08



BANK OF THE WEST
BNP PARIBAS
WEALTH MANAGEMENT

WBSD - RECYCLED WATER SRF RESERVE

Account Number:
Statement Period:

07/01/20 -
09/30/20

SECURITY PRICES CONTAINED IN THIS STATEMENT ARE OBTAINED FROM THE MOST RELIABLE SOURCES AVAILABLE BUT ARE NOT GUARANTEED BY BANK OF THE WEST. QUOTED PRICES MAY NOT EQUAL ACTUAL PRICES BECAUSE OF SECURITY SIZE, MARKET PRICE, TERM AND DEMAND.



Electronic Funds Transfers

Preauthorized Transfers:

You may request an electronic fund transfer (EFT), such as an ACH transfer from or deposit to your account, by contacting your account Administrator. You may also preauthorize periodic EFTs by contacting your account Administrator. If you would like to know whether a preauthorized EFT has occurred, please contact your account Administrator at the phone number listed on the first page of your statement, or call 1-877-898-1003 (TTY 1-800-659-5495) between the hours of 8:00 A.M. to 5:00 P.M. Pacific Standard Time.

Error Resolution Notice:

If you think a statement or receipt is wrong or if you need more information about an EFT listed on a statement or receipt, telephone us at 1-877-898-1003 (TTY 1-800-659-5495) between the hours of 8:00 A.M. to 5:00 P.M. Pacific Standard Time, write to us at Bank of the West, 13300 Crossroads Parkway North, City of Industry, CA 91746, or e-mail us at WMGGIFSOperations@bankofthewest.com as soon as possible. We must hear from you no later than 60 days after we sent the FIRST statement on which the problem or error appeared.

1. Tell us your name and account number (if any).
2. Tell us the dollar amount of the suspected error.
3. Describe the error or the transfer you are unsure about, and explain as clearly as you can why you believe it is an error or why you need more information.

If you contact us verbally, we may require that you send us your complaint or question in writing within 10 business days. We will investigate your complaint and will correct any error promptly. If we take more than 10 business days to do this, we will credit your account for the amount you think is in error, so that you will have the use of the money during the time it takes us to complete our investigation.

THIS PAGE LEFT INTENTIONALLY BLANK



**WEST BAY SANITARY DISTRICT
AGENDA ITEM 7D**

To: Board of Directors

**From: Bill Kitajima, Projects & IT Manager
Jonathan Werness, Engineering Technician**

**Subject: Consider Resolution Authorizing the President and Secretary to
Enter into Agreement Creating Covenants Running With the
Land for 17 Redberry Ridge, Portola Valley**

Background

The attached agreement requires that a property owner, who seeks inclusion in the District's On-Site Wastewater Disposal Zone, shall protect and maintain certain portions of the system to ensure continuity of service.

Analysis

It had been staff's experience that transfer of the property from one owner to another invariably resulted in a failure to maintain the system as previously agreed. The attached Covenants of Agreements Running with the Land ensures that all future owners are required to comply with the District's Code of General Regulations and Specifications.

Fiscal Impact

Property owners have paid all annexation fees and the fiscal impact would be additional sewer service charge revenue to the District once the parcel is connected.

Recommendation

The Projects & IT Manager recommends the Board to approve the Resolution as presented.

Attachments: Resolution _____ (2020)
Covenants Running with the Land

RESOLUTION NO. _____ (2020)

RESOLUTION APPROVING AND AUTHORIZING EXECUTION OF “AGREEMENT CREATING COVENANTS RUNNING WITH THE LAND,” BY AND BETWEEN DAVID YAN, OWNER OF REAL PROPERTY, AND THE WEST BAY SANITARY DISTRICT

The District Board finds and determines as follows:

- A. The proposed Agreement provides adequate protection for the District’s interests so as to justify the requested action.

Based upon the foregoing findings and determinations,

IT IS RESOLVED by the District Board as follows:

The Agreement is approved and the President and Secretary are authorized and directed to execute the Agreement. The District Manager is directed to record the Agreement in the Official Records of San Mateo County.

Passed and adopted by the District Board of the West Bay Sanitary District at a regular meeting thereof held on the 28th day of October 2020, by the following vote.

AYES:

NOES:

ABSTAIN:

ABSENT:

President of the District Board of the
West Bay Sanitary District of San
Mateo County, State of California

Attest:

Secretary of the District Board of the
West Bay Sanitary District of San
Mateo County, State of California

Recording Requested By:)
)
 WEST BAY SANITARY DISTRICT)
)
 And When Recorded, Mail To:)
)
 West Bay Sanitary District)
)
 500 Laurel Street)
)
 Menlo Park, California 94025-3486)
)
 Attn: District Manager)

(Space above this line for Recorder's Use)

**AGREEMENT CREATING COVENANTS
 RUNNING WITH THE LAND**

Agreement entered into by and between West Bay Sanitary District, a public agency of the State of California ("District") and David Yan, owners of the property at 17 Red Berry Ridge, ("Proponents").

RECITALS

1. Proponents represent that they are the owners of certain real property situated in the Town of Portola Valley, San Mateo County, California, which is commonly known as Unincorporate Santa Clara County, and which is more particularly described as follows:

Lot 13 in Block 01, as shown on that certain map entitled "BLUE OAKS", filed in the office of the County Recorder of said County and State, on JUNE 19, 1998 in Book 128 of maps at pages 6A-92.

Containing an area of 1.98 acres, more or less (the "Real Property").

2. *Proponents' Real Property is developed with a single family residence. The residence is served by a septic tank/leachfield wastewater disposal system that has failed and cannot be repaired. Use of the present system must be discontinued or it is probable that conditions adversely affecting the public health, safety and welfare will develop on the Real Property and, potentially, off-site.*

or

Proponents' Real Property is developed with a single family residence. The residence is served by a septic tank/leachfield wastewater disposal system that is unable to meet current standards.

or

Proponents' Real Property is undeveloped. The proposed residence can not be served by a septic tank/leachfield wastewater disposal system.

3. To maintain wastewater disposal service to the site, Proponents have annexed the Real Property to the District and are seeking service from the District.

4. To obtain District administered wastewater disposal services for the Real Property, Proponents propose to construct certain unconventional wastewater disposal facilities (the "Septic Tank Effluent Pumping (STEP)" / "Grinder Pump System"), 21 linear feet of sanitary sewer main and to connect to the District's public facilities located in UNINCORPORATED SANTA CLARA COUNTY

5. The STEP/Grinder Pump System to be constructed by Proponents is similar to several other wastewater disposal systems constructed on other properties within the District which also connect to the District's sewer system. These systems differ substantially from traditional gravity sewer systems found elsewhere in the District's service area, and because of these differences, the District is regulating the use and operation of these systems through an On-Site Wastewater Disposal Zone. (See Health & Safety Code Sections 6950 et seq.; "The Zone".)

6. Proponents are willing to accept the stated conditions and they desire to enter into this Agreement with the District to fulfill the intentions of the parties.

TERMS AND CONDITIONS

In consideration of the foregoing Recitals and the following Terms and Conditions, it is mutually agreed by District and Proponents as follows:

1. The Proponents shall construct a new STEP/Grinder Pump System according to the District's Standard Details. All pumping equipment, control equipment, telemetry equipment, pipelines, power and phone lines, etc., are a part of the construction costs to be borne by the proponent. The applicant shall submit information about the location, type and size of all equipment and facilities to the District for review and approval. Final determination of the size, location and equipment used in the construction of the STEP/Grinder Pump System shall be at the sole discretion of the District.
2. The Proponents shall coordinate all inspection and testing with the District. The Proponents shall notify the District 48 hours in advance for inspections and testing. After completion of the initial construction, the Proponents shall guarantee the work for one-year by a maintenance bond or cash deposit for 50% of the work.
3. The Proponents shall supply the District with one extra pump of the same type and size to be installed.
4. A recorded easement on the individual property is required for District access to the STEP/Grinder Pump System for routine maintenance and repair. This easement must meet the requirements of the District's Code of General Regulations, be granted to the District, and must be recorded on the title of the property. The District must have full vehicular access at all times to the areas with wastewater facilities.
5. Any septic tanks to be abandoned shall be abandoned in accordance with County Health requirements and copy of abandonment permit is given to the District.
6. The Proponents and their successor shall be responsible to provide and maintain the following appurtenances:
 - (a) A dedicated telephone line.
 - (b) Electrical power for the telemetry and grinder system.
 - (c) A separate 220 Volt circuit and breaker shall be provided for the STEP/Grinder Pump and shall be labeled in the circuit box as, "Do Not Touch - For STEP/Grinder Pump Use Only."

7. The proponent shall disclose to the District any secondary pumping system and changes to the internal plumbing of the residence prior to any work and connection to the grinder system. The District reserves the right to reject any Proposal/ Design which may impact the ability of the STEP/Grinder System to function effectively or result in excessive maintenance costs. Such determination shall be made at the sole discretion of the District.

8. All costs associated with the correction of the prohibitions referenced in this agreement shall be conducted at the sole cost of the Property Owner. The District shall invoice the Property Owner directly. The charge shall be the actual salary of District employees and equipment for the time necessary for the correction times 1.75, or the actual cost of Contractors Services, times 1.75. Such costs may be charged in addition to penalties authorized by the District's Code of General Regulations.

PROHIBITIONS

In addition to the Prohibitions contained in the District's Code of General Regulations, the following prohibitions shall specifically apply to properties in the District's On-Site Wastewater Disposal Zone:

1. Proponents shall not under any circumstances, change or add any secondary pumping systems without the written consent of the District.

2. Proponents shall not, under any circumstances, allow or permit changes to the infrastructure or equipment of the STEP/Grinder Pumping System without the written consent of the District. Proponents are specifically instructed not to allow disconnection or reconfiguration of telephone and electrical systems.

3. The proponent shall not under any circumstances connect swimming pool, spa, or any storm drains to piping that discharges into the grinder pump unit.

ADHERENCE TO DISTRICT REGULATIONS

With respect to all matters referred to in this Agreement, including the construction of the STEP/Grinder Pump System, its connection to the District's system, the use and operation of the STEP/Grinder Pump System and the use of the District's wastewater facilities, Proponents shall at all times fully comply with all applicable District regulations. Proponents shall operate and maintain the STEP/Grinder Pump System so that at all times it remains in good operating condition and repair. Except to the extent District accepts responsibility for some portion or portions of Proponents' STEP/Grinder Pump System and the systems of other persons similarly situated and for which the District hereafter imposes a uniform system of fees and charges applicable to all such persons, the responsibility, including all costs and expenses, for the construction, use, operation, maintenance, repairs and replacement of the Grinder Pump System shall be borne exclusively by Proponents, and the District shall have no responsibility for such matters whatsoever.

ENFORCEMENT RIGHTS OF DISTRICT

In addition to the rights and remedies established by this Agreement, the District shall have all rights and remedies otherwise afforded under applicable provisions of law to enforce this Agreement, including (a) Proponents' obligation to pay and the District's right to collect fees and charges and (b) District's right to correct violations of District's regulations.

ATTORNEY FEES

In the event of any litigation between the parties to interpret or enforce this Agreement, the prevailing party shall be entitled to recover its attorney fees, court costs and litigation expenses incurred in the litigation.

BINDING EFFECT

This Agreement shall be binding upon and inure to the benefit of the respective parties, their assigns, beneficiaries, personal representatives and successors in interest.

Executed at Menlo Park, California on the dates set forth.

DISTRICT:

WEST BAY SANITARY DISTRICT
A Public Agency

Printed Name:

By: _____ Date: _____
President of the District Board

Printed Name:

And by: _____ Date: _____
Secretary of the District Board

PROPONENTS:

Printed Name: DAVID YAN

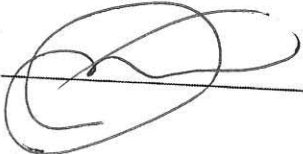
By:  _____ Date: 06/24/20

Printed Name: Alena Yan

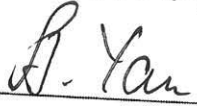
By:  _____ Date: 06/24/20

(Attach Notary Acknowledgement Certificate)

ACKNOWLEDGMENT

A notary public or other officer completing this certificate verifies only the identity of the individual who signed the document to which this certificate is attached, and not the truthfulness, accuracy, or validity of that document.

State of California
County of San Mateo)

On 06/24/20 before me, R. Padilla, Notary Public
(insert name and title of the officer)

personally appeared Alena Yan and David Yan,
who proved to me on the basis of satisfactory evidence to be the person(s) whose name(s) is/are
subscribed to the within instrument and acknowledged to me that he/she/they executed the same in
his/her/their authorized capacity(ies), and that by his/her/their signature(s) on the instrument the
person(s), or the entity upon behalf of which the person(s) acted, executed the instrument.

I certify under PENALTY OF PERJURY under the laws of the State of California that the foregoing paragraph is true and correct.

WITNESS my hand and official seal.

Signature  (Seal)

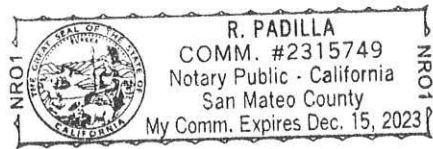



WEST BAY SANITARY DISTRICT AGENDA ITEM 8

To: *Board of Directors*

From: *Sergio Ramirez, District Manager*

Subject: *October 28th Update Report on District Response to Corona Virus*

Background

In early March of 2020, the outbreak of Corona Virus in the USA caused Federal, State and Local governments to enact several laws, regulations and guidelines to mitigate the impact of the spread and severity of the virus including Shelter in Place. The District has been busy employing measures to meet those regulations and guidelines as well as taking action to ensure the safe working conditions of staff and minimize exposure of and interaction with the public.

Analysis

The District has thus far taken action in regards to: Shelter in Place, Social Distancing, Personal Protective Equipment, and the Injury and Illness Prevention Program (IIPP).

Shelter in Place: The District as a wastewater agency has been designated as an “Essential Service” and supplied employees with letters drafted by legal counsel that can be shown to legal authorities, if required, to justify their travel to, during and from work. In addition, the District has developed a Modified Work Schedule that requires individuals to stay at home or telecommute in order to reduce interaction and thus the potential of any spread of the virus among District staff. The District has also implemented the use of Zoom for meetings to reduce the need for consultants, partners, the public and Board member to attend in person. A camera and large screen have been installed to accommodate this mode of virtual meetings.

Social Distancing: District staff has employed several measures related to Social Distancing including; limiting meeting size to 10, marking seating spots at tables with 6 foot separation, signage encouraging 6 foot distancing, separation of reporting stations to include the FERRF, Plexi-glass shields at the counter and between workspaces that cannot achieve 6 foot distancing, and closing of the District Office to the public unless by appointment.

Report to the District Board for the Regular Meeting of October 28, 2020

Personal Protective Equipment (PPE): The District has been engaged in supplying employees and Board members with several forms of Personal Protective Equipment and emphasizing the frequent and regular use of this equipment. These items include: The distribution of hand sanitizer to employees and Board members, wipes for counters, chairs and tables, installation of hand sanitizer at counter, tables and offices, N95 masks to all employees, increased counts coveralls, face shields, goggles etc.

This has caused the District to reassess its inventory and at what levels of existing stock should trigger new orders so that the District can maintain adequate levels of important supplies to carry us not only through traditionally thought of natural disasters but pandemics such as this. To that end staff has developed an improved inventory check list that includes contact information for ordering, expected lag times in ordering, minimum levels of stock, Trigger-levels for ordering, dates of stock added to inventory and so on. This should help us be better prepared for future events where PPE can be in short supply or difficult to obtain and District operations can continue uninterrupted.

Injury and Illness Prevention Program: The District has made a significant effort in the way of training employees in how to deal with the COVID 19 response. We have developed SOP's for both field staff and office staff in dealing with customers while maintaining social distancing, utilizing PPE, and remote permitting etc. We have complied with local health officials requirement to complete and post at all entrances the Social Distancing Protocols and used that and our SOP's as a basis for developing a comprehensive COVID 19 Preparedness and Response program.

The District has taken great efforts to inform the public of changes in business procedures during this time including website postings, posting notices and information on all entrance doors, mailings of letters and flyers to residents, and ads in Facebook and YouTube. The use of Wipes has emerged as a huge problem for the District and our outreach has included addressing this problem in the flyers, ads, and correspondence to persuade our constituents to refrain from flushing wipes.

May 13 update: The District has found that it takes at least 3 weeks from the date of order to delivery of consumable PPE items such as; N95 face masks (we have received 2,000 masks since the first March order), 500 face shields, and 150 goggles to protect the field staff from droplets and mist while cleaning the sewer lines.

The District will now be faced with transitioning back to normal operations. The District Office is open on Friday by appointment only. Construction activities are increasing and inspections are being scheduled much more frequently. Social Distancing and PPE will continue to be key elements of District life for the foreseeable future.

May 27 update: The District has opened the office to the public on Tuesdays and Thursdays. Stickers on the floors and notices on the doors and shields at the counters have been placed to remain compliant with the Health Dept. Wipes and signs have been placed in the bathrooms. All the departments except Administration have

returned to normal work hours (which are mostly 9/80 schedule but crews are still separated with the Satellite Office/Corp Yard. As a result of these changes have updated the COVID 19 response plan and affixed to entry doors as required.

June 10 update: Staff is resuming normal Pre-COVID 19 work schedules beginning June 8, with the exception of some of the Admin staff. Office hours will open up to Monday through Thursday 9am to 3pm.

June 24 update: As of Friday, June 12 the Administration Office was open by appointment. Office hours continue to be open Monday through Thursday 9am to 3pm. Staff is continuing to make a concerted effort to be available to the public and contractors for business.

July 8 update: The current YouTube advertisement advising customers not to flush wipes or towels has been viewed by 220,653 people and 24% or 50,759 have viewed the video to completion.

August 12 update: When an employee has been in contact with a known or possible COVID 19 positive patient or been in contact with someone who has been in contact with a confirmed COVID 19 positive patient they will be asked to stay home for a 14-day self-quarantine period and will be asked to be tested for COVID 19. If the employee is well enough during the self-quarantine period, they will work from home during this time. As soon as the employee is COVID 19 negative, they will be asked to return to work.

September 9 update: The District's COVID-19 Preparedness and Response Program has been updated through DuAll Safety to include usage of current San Mateo County Health Department signage, updated social distancing protocol (verbiage and links for continuing SIP order), CDC updates on Coronavirus symptoms, addition of cloth face mask and San Mateo County Health guidelines. Training to be scheduled for September with DuAll Safety (by ZOOM) for all current updates. Staff has purchased two disinfecting fog machines to disinfect surfaces in the Admin and Maintenance Buildings, and Operations Building at FERFF. Disinfection of surface are being done weekly.

September 23 update: Two employees are currently out sick and in quarantine due to a possible exposure to COVID-19 per District's protocol memorialized in our August 12, 2020 update (above) "*When an employee has been in contact with a known or possible COVID 19 positive patient or been in contact with someone who has been in contact with a confirmed COVID 19 positive patient they will be asked to stay home for a 14-day self-quarantine period and will be asked to be tested for COVID 19.*" Once the employees test negative for COVID-19, or quarantine for 14 days, they will be allowed back to work.

October 14 update: No updates at this time.

October 28 update: Updated training on the Response Program will be conducted in October. Two office employees were experiencing COVID-19 symptoms and were asked to work from home until test results were available. Both employees tested negative and have returned to work.

Fiscal Impact

While there has been considerable expense to implementing some of the COVID 19 mitigation measures such as; converting the FERRF office space (approx. \$2,000), purchasing PPE for stock (\$8,000 to \$10,000), Public Outreach (\$10,500), Zoom Meeting Equipment (approx. \$6,000) these expenses were absorbed in the Operating budget. The FY2020-21 Budget could be substantially impacted by the effects of the national COVID 19 response. To date approximately \$5300.00 has been spent in PPE, \$2000.00 in disinfecting equipment, and \$1927.00 in producing and updating the COVID 19 Response Plan.

Recommendation

The District Manager recommends the Board accept this report and provide comments to the District Manager in regards to the report. Additional information may be available at the Board meeting as conditions and responses are rapidly changing throughout the COVID 19 pandemic.



**WEST BAY SANITARY DISTRICT
AGENDA ITEM 9**

To: Board of Directors

From: Sergio Ramirez, District Manager

**Subject: Report and Discussion on the West Bay and Sharon Heights
Recycled Water Plant**

A discussion will be held on the Sharon Heights Recycled Water Plant and other events related to the recycled water plant. The Board will have opportunity to provide direction to staff and legal counsel.

The following is a disclosure statement required for any document, written report or brochure prepared in whole or in part pursuant to the Finance Agreement with the State Water Resources Control Board for the West Bay Sanitary District Recycled Water Project - Sharon Heights:

Funding for this project has been provided in full or in part through an agreement with the State Water Resources Control Board. California's Clean Water State Revolving Fund is capitalized through a variety of funding sources, including grants from the United States Environmental Protection Agency and state bond proceeds. The contents of this document do not necessarily reflect the views and policies of the foregoing, nor does mention of trade names or commercial products constitute endorsement or recommendation for use.

THIS PAGE LEFT INTENTIONALLY BLANK



**WEST BAY SANITARY DISTRICT
AGENDA ITEM 10**

To:*Board of Directors*

From:*Sergio Ramirez, District Manager*

Subject:*Discussion and Direction on the Bayfront Recycled Water Project*

A discussion will be held on the Bayfront Recycled Water Project and other events related to the recycled water project including financing, environmental review, design/build issues and grant applications. The Board will have opportunity to provide direction to staff and legal counsel.

THIS PAGE LEFT INTENTIONALLY BLANK



**WEST BAY SANITARY DISTRICT
AGENDA ITEM 11**

To: Board of Directors

From: Sergio Ramirez, District Manager

Subject: Report and Discussion on South Bayside Waste Management Authority (SBWMA)

The District's representative to South Bayside Waste Management Authority (SBWMA), President Fran Dehn, will report on any pertinent items regarding SBWMA business.

THIS PAGE LEFT INTENTIONALLY BLANK



**WEST BAY SANITARY DISTRICT
AGENDA ITEM 12**

To: Board of Directors

From: Sergio Ramirez, District Manager

**Subject: Report and Discussion on Silicon Valley Clean Water (SVCW)
Plant**

The District's representative to Silicon Valley Clean Water (SVCW), Commissioner George Otte, will report on pertinent items regarding SVCW Operations, CIP and Finance.

Report to the District Board for the Regular Meeting of October 28, 2020

THIS PAGE LEFT INTENTIONALLY BLANK