

*1902 - Serving Our Community for over 115 Years - 2021*  
**WEST BAY SANITARY DISTRICT  
AGENDA OF BUSINESS  
REGULAR MEETING OF THE DISTRICT BOARD  
WEDNESDAY, JUNE 9, 2021 AT 7:00 P.M.  
RONALD W. SHEPHERD ADMINISTRATION BUILDING,  
500 LAUREL STREET, MENLO PARK, CALIFORNIA 94025**

**Board Members**

Fran Dehn, President  
David Walker, Secretary  
Roy Thiele-Sardiña, Treasurer  
Edward P. Moritz, Member  
George Otte, Member

**District Manager**

Sergio Ramirez

**District Legal Counsel**

Anthony Condotti, Esq.

**AGENDA OF BUSINESS**

**NOTICE OF PUBLIC PARTICIPATION BY TELECONFERENCE or ZOOM ONLY**

Pursuant to Governor Newsom's Executive Order N-29-20, members of the West Bay Sanitary District Board of Directors and Staff may participate in this meeting via a teleconference. In the interest of reducing the spread of COVID- 19, members of the public are allowed to participate telephonically only, and may submit comments in advance by email addressed to [treese@westbaysanitary.org](mailto:treese@westbaysanitary.org) by 4:00 p.m. on Wednesday, June 9<sup>h</sup>.

To participate by telephone or Zoom meeting, public comments can be made by joining Zoom meeting at: <https://zoom.us/j/94808535966?pwd=eW4vakpESVFFdFA2bDdJV2dYbExzUT09>  
Meeting ID: 948 0853 5966 Passcode: 440934

Or by phone, call: 1-669-900-6833 Meeting ID: 948 0853 5966 Passcode: 440934

Following receipt of public comment and open session items, the Board will adjourn to closed session. Reportable action, if any, will be available upon inquiry within twenty-four (24) hours.

***NOTE: The Board may take action on any agendized item unless specifically designated a "discussion" item or a "report."***

1. Call to Order and Roll Call
2. Communications from the Public
3. Public Hearing - Annexing Certain Territory Within the West Bay Sanitary District's On-Site Wastewater Disposal Zone – Lands of Turnquist (4 Navajo Place, Portola Valley) Zone Pg. 3-1
4. Consideration of Adopting Resolution Ordering Annexation of Certain Parcels in the Territory of West Bay Sanitary District to the West Bay Sanitary District's On-Site Wastewater Disposal Zone Including Certain Determinations, Findings and Declarations of the District Board – Lands of Turnquist (4 Navajo Pl, Portola Valley)Pg. 4-1

5. Consent Calendar

*Matters listed under this item are considered routine and will be enacted by one motion. The motion, seconds, and vote are applicable to any included resolutions and recorded accordingly. There will be no separate discussion of these items unless specifically requested by a member of the Board.*

- A. Approval of Minutes for Regular meeting May 26, 2021 Pg. 5A-1
  - B. Approval of the Financial Activity Report Authorizing Payment of Certain Bills and Salaries and Consideration of Other Financial Matters thru May 31, 2021 Pg. 5B-1
  - C. WBSD Operations and Maintenance Report – May 2021 Pg. 5C-1
  - D. Town of Los Altos Hills Operations and Maintenance Report for Work Performed by WBSD – May 2021 Pg. 5D-1
  - E. Town of Woodside Operations and Maintenance Report for Work Performed by WBSD – May 2021 Pg. 5E-1
  - F. Consideration of Resolution Consenting to Annexation of Territory to the West Bay Sanitary District by the San Mateo County Local Agency Formation Commission – 4 Navajo Place, Portola Valley (077-300-130), Lands of Turnquist PV Pg. 5F-1
  - G. Consideration of Authorizing the District Manager to Consent to the Relocation of Public Utility Easement at 104 & 110 Constitution Drive and 115 Independence Drive, Menlo Park, properties of the Menlo Portal Project Pg. 5G-1
  - H. Bank of the West Monthly Investment Portfolio Statements Pg. 5H-1
6. Consideration to Approve Contract Change Order No. 1 to Aztec Consultants, Inc. for the New Metal Storage Building Project in Menlo Park, CA Pg. 6-1
7. District Manager’s Report Pg. 7-1
8. Discussion on Local Agency Investment Fund (LAIF) Allocations Pg. 8-1
9. Consideration to Approve the District Reserve Policy Pg. 9-1
10. Consideration to Approve Budget Revision for FY 2020-21 to Reallocate Reserve Contribution from Operating Reserve to the Rate Stabilization Reserve Pg. 10-1
11. Consideration to Approve Resolution Adopting FY 2021-22 Budget Pg. 11-1
12. June 9<sup>th</sup> Update Report on District Response to Corona Virus Pg. 12-1
13. Report and Discussion on Sharon Heights Recycled Water Plant Pg. 13-1
14. Discussion and Direction on Bayfront Recycled Water Project and Status Update Pg. 14-1
15. Report and Discussion on South Bayside Waste Management Authority (SBWMA) Pg. 15-1
16. Report and Discussion on Silicon Valley Clean Water (SVCW) Plant Pg. 16-1

17. Closed Session

A. PUBLIC EMPLOYEE PERFORMANCE EVALUATION/CONF. WITH LABOR NEGOTIATORS

Agency designated representatives: District Manager/Legal Counsel  
Unrepresented & Exempt employees: Unrepresented & Exempt Staff

B. PUBLIC EMPLOYEE PERFORMANCE EVALUATION/CONF. WITH LABOR NEGOTIATORS

Agency designated representatives: Board President/Legal Counsel  
Unrepresented employee: District Manager

18. Consideration to Adopt Resolution Establishing Rates of Pay and Related Compensation Provisions Pg. 18-1

19. Comments or Reports from Members of the District Board and Consider Items to be Placed on Future Agenda

20. Adjournment

The West Bay Sanitary District does not discriminate against persons with disabilities. Upon request, the agenda and agenda packet can be provided in a format to accommodate special needs. If you require a copy of the agenda or related materials in an alternative format to accommodate a disability, or if you wish to attend this public meeting and will require special assistance or other special equipment, please call the District at (650) 321-0384 at least five days in advance and we will make every reasonable attempt to provide such an accommodation.

THIS PAGE LEFT INTENTIONALLY BLANK





## WEST BAY SANITARY DISTRICT AGENDA ITEM 3

**To:** *Board of Directors*

**From:** *Bill Kitajima, Projects & IT Manager  
Jonathan Werness, Engineering Technician*

**Subject:** *Public Hearing - Annexing Certain Territory Within the West Bay Sanitary District's On-Site Wastewater Disposal Zone – Lands of Turnquist (4 Navajo Place, Portola Valley)*

---

### Background

On April 14, 2021, the Board adopted a Resolution of intention to annex the parcel referenced above to the District's On-Site Wastewater Disposal Zone. The Public Hearing date was established as June 9, 2021.

### Analysis

The District's **Master Resolution Governing Annexations of Territory to the West Bay Sanitary District On-Site Disposal Zone** states: "Pursuant to Section 6959 of the Health and Safety Code, the date of the Public Hearing shall be commenced no less than 45 days nor more than 60 days from the date of adoption of the Resolution of Intention, and the Public Hearing shall be completed no more than 90 days after the first day of the hearing."

In accordance with Section 6960, and 6960.1 of the same code, reviews and reports of findings are required of both the County Health Officer and Regional Water Quality Control Board. Additionally, Section 6960.3 of this code requires the review and approval by a local agency formation commission, which has adopted rules and regulations affecting the functions and services of special districts.

The San Mateo County Health Officer has responded by a letter of approval dated May 19, 2021 a copy of which is attached; the San Francisco Bay Regional Water Quality Control Board responded by a letter of approval dated May 18, 2021, a copy of which is attached; and the San Mateo Local Agency Formation Commission has approved per their Resolution No. 1257 dated January 20, 2021, a copy of which is attached.

### Fiscal Impact

Property owners have paid all annexation fees and the fiscal impact would be additional sewer service charge revenue to the District once the parcel is connected.

---

Recommendation

The Board is asked to close the Public Hearing following public comment.

Attachments: San Mateo County Health Officer Letter

San Francisco Bay Regional Water Quality Control Board Letter

San Mateo Local Agency Formation Commission Resolution No. 1257



May 19, 2021

APN 077-300-130

Bill Kitajima  
West Bay Sanitary District  
500 Laurel Street  
Menlo Park, CA 94025

Dear Mr. Kitajima:

**SUBJECT: ANNEXATION, 4 NAVAJO PLACE, PORTOLA VALLEY,  
APN 077-300-130**

Thank you for the May 18, 2021, letter of *Intention to Annex Certain Territory* to District's On-Site Wastewater Disposal Zone for the subject parcel. County Environmental Health has reviewed the letter of intent and has no objection to the annexation of this parcel into the District's on-site wastewater disposal zone. The existing onsite wastewater treatment system(s) (OWTS) must be destroyed under permit with Environmental Health upon connection to the West Bay system.

Should you have any questions, please call me at (650) 372-6279.

Sincerely,

Gregory J. Smith, PG, REHS  
Supervisor Water Protection and Land Use Programs

cc: Laura Russell, Planning Director, Town of Portola Valley





---

## San Francisco Bay Regional Water Quality Control Board

May 18, 2021  
File: CW-255833

Bill Kitajima ([bkitajima@westbaysanitary.org](mailto:bkitajima@westbaysanitary.org))  
Projects & IT Manager  
West Bay Sanitary District  
500 Laurel Street  
Menlo Park, California 94025-3486

### **Approval to Annex Certain Territory (Lands of Turnquist) to the West Bay Sanitary District On-Site Wastewater Disposal Zone: APN: 077-300-130**

Dear Bill Kitajima:

The Regional Water Board hereby approves the annexation of the subject parcel to the On-Site Wastewater Disposal Zone of the West Bay Sanitary District (District). The property owners applied to the District for annexation “for the purpose of obtaining sewer service for a single-family residence.” To connect to existing District sewer facilities, the property owners require a Grinder Pump System that the District must maintain. Therefore, this parcel must be annexed into the District's disposal zone.

The Regional Water Board's approval is conditional upon the District (1) retaining responsibility for operation and maintenance of the grinder pump system, and (2) ensuring the proper operation and maintenance of the other sewerage facilities serving the parcel. Disposal of sewage onto soils within the disposal zone is not approved.

If you have any questions, please contact me at (510) 622-2407, or via e-mail at [gaurav.mittal@waterboards.ca.gov](mailto:gaurav.mittal@waterboards.ca.gov).

Sincerely,

Gaurav Mittal  
Water Resource Control Engineer

Exhibit C

SAN MATEO



**LOCAL AGENCY FORMATION COMMISSION**

455 COUNTY CENTER, 2ND FLOOR • REDWOOD CITY, CA 94063-1663 • PHONE (650) 363-4224 • FAX (650) 363-4849

**CERTIFICATE OF COMPLETION**

Pursuant to Government Code Section 57200, this Certificate is issued by the Executive Officer of the Local Agency Formation Commission of San Mateo County, California.

1. The short-form designation, as determined by LAFCo, is Annexation of 4 Navajo Place, Portola Valley to the West Bay Sanitary District.
2. The name of each district or city involved in this change of organization or reorganization and the kind or type of change of organization ordered for each city or district are as follows:

<u>City or District</u>	<u>Type of Change of Organization</u>
-------------------------	---------------------------------------

West Bay Sanitary District	Annexation
----------------------------	------------

3. The above-listed cities and/or districts are located within the following counties: San Mateo County only.
4. A description of the boundaries of the above-cited change of organization or reorganization is shown on the attached map, marked Exhibit A and by reference incorporated herein.
5. The territory involved in this change of organization or reorganization is uninhabited.
6. This change of organization has been approved subject to the following terms and conditions, if any: None.
7. The resolution confirming this change of organization was adopted on January 20, 2021 by LAFCo, is marked Exhibit B, and by reference incorporated herein.

I hereby certify that I have examined the above-cited resolution, including any terms and conditions, and the map description and have found these documents to be in compliance with Resolution 1257, adopted on January 20, 2021.

Dated: March 2, 2021

  
 Martha Poyatos  
 Executive Officer

**COMMISSIONERS:** WARREN SLOCUM, CHAIR, COUNTY ▪ MIKE O'NEILL, VICE CHAIR, CITY ▪ HARVEY RARBACK, CITY ▪ DON HORSLEY, COUNTY ▪ JOSHUA COSGROVE, SPECIAL DISTRICT ▪ RIC LOHMAN, SPECIAL DISTRICT ▪ ANN DRAPER, PUBLIC

**ALTERNATES:** KATI MARTIN, SPECIAL DISTRICT ▪ DIANA REDDY, CITY ▪ JAMES O'NEILL, PUBLIC ▪ DAVE PINE, COUNTY ▪ MARTHA POYATOS, EXECUTIVE OFFICER ▪ REBECCA ARCHER, LEGAL COUNSEL ▪ ROB BARTOLI, MANAGEMENT

**STAFF:** ANALYST ▪ ANGELA MONTES, CLERK

LAFCo File No. 20-09

RESOLUTION NO. 1257

**RESOLUTION OF THE LOCAL AGENCY FORMATION COMMISSION  
OF THE COUNTY OF SAN MATEO  
MAKING DETERMINATIONS, APPROVING LAFCO FILE 20-09 -  
ANNEXATION OF 25 NAVAJO PLACE, PORTOLA VALLEY  
TO THE WEST BAY SANITARY DISTRICT,  
WAIVING CONDUCTING AUTHORITY PROCEEDINGS, AND ANNEXATION  
TO THE ON-SITE WASTEWATER DISPOSAL ZONE**

APPROVED  
SAN MATEO LOCAL AGENCY  
FORMATION COMMISSION  
455 COUNTY CENTER  
REDWOOD CITY, CA 94063  
EXHIBIT B PAGE 1 OF 3

RESOLVED, by the Local Agency Formation Commission of the County of San Mateo, State of California, that

WHEREAS, a proposal for the annexation of certain territory to the West Bay Sanitary District in the County of San Mateo was heretofore filed with the Executive Officer of this Local Agency Formation Commission pursuant to Title 5, Division 3, commencing with Section 56000 of the Government Code; and

WHEREAS, the Executive Officer has reviewed the proposal and prepared a report, including the recommendations thereon, the proposal and report having been presented to and considered by this Commission; and

WHEREAS, it appears to the satisfaction of this Commission that all owners of the land included in the proposal consent to the proceeding; and

WHEREAS, a public hearing by this Commission was held on the proposal and at the hearing this Commission heard and received all oral and written protests, objections and evidence which were made, presented or filed, and all persons present were given an opportunity to hear and be heard with respect to the proposal and the Executive Officer's report; and

WHEREAS, the landowners and District have requested that the Commission waive conducting authority proceedings pursuant to government code Section 56837(c); and

WHEREAS, the proposal is categorically exempt from the environmental review requirements of

the California Environmental Quality Act (CEQA) under State CEQA Guidelines Section 15319(a) & (b) (Annexations of Existing Facilities and Lots for Exempt Facilities); and

NOW, THEREFORE, the Local Agency Formation Commission of the County of San Mateo DOES HEREBY RESOLVE, DETERMINE AND ORDER as follows:

Section 1. This proposal is approved, subject to the following conditions: None.

Section 2. The boundaries as set forth in the application are hereby approved as submitted and are as described in Exhibit "A" attached hereto and by this reference incorporated herein.

Section 3. The territory consists of 1.5 acres, is found to be uninhabited, and is assigned the following distinctive short form designation: Annexation of 4 Navajo Place, Portola Valley to the West Bay Sanitary District.

Section 4. Conducting authority proceedings are hereby waived in accordance with Government Code Section 56663 and this annexation is hereby ordered.

Section 5. Subsequent annexation to the On-Site Wastewater Disposal Zone is hereby approved.

APPROVED  
SAN MATEO LOCAL AGENCY  
FORMATION COMMISSION  
455 COUNTY CENTER  
REDWOOD CITY, CA 94063  
EXHIBIT B PAGE 2 OF 3

Regularly passed and adopted this 20th day of January 2021.

Ayes and in favor of said resolution:

Commissioners: Ann Draper  
Don Horsley  
Ric Lohman  
Kati Martin (Alternate Special District)  
Harvey Rarback  
Mike O'Neill  
Warren Slocum

Noes and against said resolution:

\_\_\_\_\_

Commissioners Absent:

APPROVED  
 SAN MATEO LOCAL AGENCY  
 FORMATION COMMISSION  
 455 COUNTY CENTER  
 REDWOOD CITY, CA 94063

EXHIBIT B PAGE 3 OF 3

Commissioners: Joshua Cosgrove



Chair  
 Local Agency Formation Commission  
 County of San Mateo  
 State of California

ATTEST:

  
 Executive Officer  
 Local Agency Formation Commission

Date: 3-2-21

I certify that this is a true and correct copy of the resolution above set forth.

Date: 3-2-21

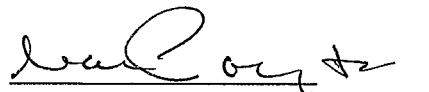
  
 Clerk to the Commission  
 Local Agency Formation Commission





**WEST BAY SANITARY DISTRICT  
AGENDA ITEM 4**

**To: Board of Directors**

**From: Bill Kitajima, Projects & IT Manager  
Jonathan Werness, Engineering Technician**

**Subject: Consideration of Adopting Resolution Ordering Annexation of Certain Parcels in the Territory of West Bay Sanitary District to the West Bay Sanitary District's On-Site Wastewater Disposal Zone Including Certain Determinations, Findings and Declarations of the District Board – Lands of Turnquist (4 Navajo Pl, Portola Valley)**

---

Background

This property at 4 Navajo Place will utilize a Grinder system; consequently this property must be annexed into the District's On-Site Wastewater Disposal Zone. The proponent shall be required to install a Grinder system that will connect to the future force main on Navajo Place currently being installed by neighbors at 20 Navajo Place.

Analysis

Following the Public Hearing to annex certain territory to the District's On-Site Wastewater Disposal Zone, the attached resolution would formally complete the annexation of the referenced Lands of Turnquist.

Fiscal Impact

Property owners have paid all annexation fees and the fiscal impact would be additional sewer service charge revenue to the District once the parcel is connected.

Recommendation

Subject to the final review by legal counsel and the findings of the resolution holding true through the public hearing (i.e., protests by less than 35 percent of the voters and landholders), it is recommended by the Projects & IT Manager that the Board adopt the resolution as drafted.

Attachment: Resolution \_\_\_\_\_ (2021), Legal/Geographic Description, Site Map

---

WEST BAY SANITARY DISTRICT

RESOLUTION NO. \_\_\_\_\_ (2021)

**RESOLUTION ORDERING ANNEXATION OF CERTAIN TERRITORY OF WEST BAY SANITARY DISTRICT TO THE WEST BAY SANITARY DISTRICT ON-SITE WASTEWATER DISPOSAL ZONE INCLUDING CERTAIN DETERMINATIONS, FINDINGS AND DECLARATIONS OF THE DISTRICT BOARD (LANDS OF TURNQUIST)**

The District Board of West Bay Sanitary District determines, finds and declares as follows:

(a) The proceedings, which are the subject of the Resolution, are undertaken pursuant to Chapter 3 of Part 2 of Division 5 (commencing with Section 6950) of the California Health & Safety (“H & S”) Code having to do with the formation of, and annexations to, on-site wastewater disposal zones.

(b) On April 14, 2021 the District Board approved and adopted Resolution No. 2239 (2021), “RESOLUTION OF INTENTION TO ANNEX CERTAIN TERRITORY TO THE WEST BAY SANITARY DISTRICT ON-SITE WASTEWATER DISPOSAL ZONE.” Among other things, Resolution No. 2239 (2021) described the area to be annexed to the zone, the name and address of the applicant and the number, type, volume and location of on-site wastewater disposal systems proposed.

(c) Pursuant to Resolution No. 2239 (2021), a public hearing was noticed in the manner required by H&S § 6958. The public hearing was commenced on June 9, 2021 and closed on June 9, 2021.

(d) Prior to the close of the hearing, the District Board received and considered reports from the following public officials and agencies as required by law:

- i. From the Public Health and Environmental Protection Division, Health Services Agency of the County of San Mateo, a letter dated May 19, 2021, constituting the report of the local health officer specifying the matters required by H & S § 6960.1.
- ii. From the California Regional Water Quality Control Board, San Francisco Bay Region, a letter dated May 18, 2021 constituting the report of the affected regional water quality control board with regard to the matters required by H & S § 6960.1 and approving the proposed plan for wastewater disposal by the affected regional water quality control board required by H & S § 6960.4.
- iii. From San Mateo Local Agency Formation Commission, a letter by which the commission approved annexation to the District and the District’s On-Site Wastewater Disposal Zone.

(e) At all times during the public hearing, the District was prepared to hear and receive any oral or written protests, objections and evidence which might be offered. No oral or written protests, objections or evidence in opposition to the proposal were made, presented or filed at any time. Therefore, pursuant to H & S § 6963, it is determined that written protests filed and not withdrawn prior to the conclusion of the public hearing represented:

- i. Less than 35 percent of the number of voters who reside in the territory to be annexed to the zone; and
- ii. Less than 35 percent of the number of owners of real property in the territory to be annexed to the zone who also own not less than 35 percent of the assessed value of real property in the territory to be annexed to the zone.

(f) The number and types of on-site wastewater disposal systems proposed to be acquired, operated, maintained and monitored in the territory to be annexed to the zone are in conformity with and do not exceed the limitations set forth in the reports referred to (d) i. and ii. above.

(g) The territory proposed for annexation to the zone contains two (2) voters as defined in the Elections Code.

(h) Operation of the zone in the territory to be annexed will not result in land uses that are not consistent with general plans, zoning ordinances or other land use regulations of the Town of Portola Valley, the County of San Mateo or any other affected public agency.

In consideration of the foregoing determinations, findings and declarations,

**IT IS RESOLVED** by the District Board as follows:

1. The territory described in Exhibit "A" shall be annexed to the West Bay Sanitary District On-Site Wastewater Disposal Zone.
2. This annexation shall be accomplished without an election and confirmation of voters within the area to be annexed shall not be required on the question of such annexation.
3. The exterior boundaries of the annexation shall include the same territory described in Exhibit "A" to Resolution No. 2239 (2021), which Exhibit "A" is attached to this Resolution and incorporated herein by reference.
4. There shall be one on-site wastewater disposal system serving one residential user in the territory to be annexed to the zone, which system the District will either acquire, operate, maintain or monitor, as the case may be, all as set forth in Exhibit "B" to Resolution No. 2239 (2021), which Exhibit "B" is attached to this Resolution and incorporated herein by reference.
5. Operations of the portions of the zone annexed herein shall be financed by a system of fees and charges imposed upon persons who make use of the on-site wastewater disposal system in the territory annexed to the zone. The fees and charges will be structured to take into account the actual costs of operating and administering the zone and the maintenance, repair and replacement of wastewater facilities within the

territory annexed to the zone. The fees and charges will, to the extent applicable, include the cost of transporting zone-generated wastewaters to appropriate wastewater treatment facilities.

\*\*\*\*\*

Passed and adopted by the District Board of West Bay Sanitary District at a regular meeting thereof held on the 9<sup>th</sup> day of June, 2021 by the following vote:

AYES:

NOES:

ABSTAIN:

ABSENT:

---

President of the District Board of the  
West Bay Sanitary District, San  
Mateo County, State of California

Attest:

---

Secretary of the District Board of the  
West Bay Sanitary District, San Mateo  
County, State of California

ANNEXATION TO WEST BAY SANITARY DISTRICT  
GEOGRAPHIC DESCRIPTION

All that certain real property situate in the Town of Portola Valley, County of San Mateo, State of California, being all of Lot 29 in Block 1, as shown on that certain map entitled "TRACT NO. 774 ARROWHEAD MEADOWS UNIT NO. 4, BEING A PORTION OF THE RANCHO EL CORTE MADERA" filed on March 17, 1959 in Volume 50 of Maps at Pages 45-48, Records of the County of San Mateo, State of California, and being more particularly described as follows:

Beginning at the centerline intersection of Meadowood Drive and Navajo Place;

Thence (1) South 73°45'00" E 25.00 feet to the intersection of the centerline of Navajo Place and the easterly line of Meadowood Drive, Thence (2) along said easterly line of Meadowood Drive South 16°15'00" West 45.00 feet to the TRUE POINT OF BEGINNING of this description:

Thence leaving said easterly line, (3) northeasterly on the arc of a curve concave southeasterly, the center of which bears South 73°45'00" East, having a radius of 20.00 feet, a chord length of 28.28 feet, a central angle of 90°00'00" and length of 31.42 feet;

Thence (4) along the southerly line of Navajo Place (50' wide right of way) South 73°45'00" East 305.31 feet;

Thence (5) leaving said southerly line, South 24°47'01" West 150.00 feet;

Thence (6) North 71°36'25" West 303.26 feet to said easterly line of Meadowood Drive (50' wide right of way);

Thence (7) along said easterly line of Meadowood Drive North 16°15'00" East 117.00 feet to the TRUE POINT OF BEGINNING.

Containing 1.03 acres, more or less.

For assessment purposes only. This description of land is not a legal property description as defined in the Subdivision Map Act and may not be used as the basis for an offer for sale of the land described.

APPROVED  
SAN MATEO LOCAL AGENCY  
FORMATION COMMISSION  
455 COUNTY CENTER  
REDWOOD CITY, CA 94063

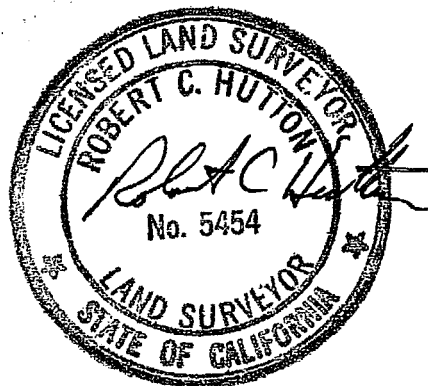
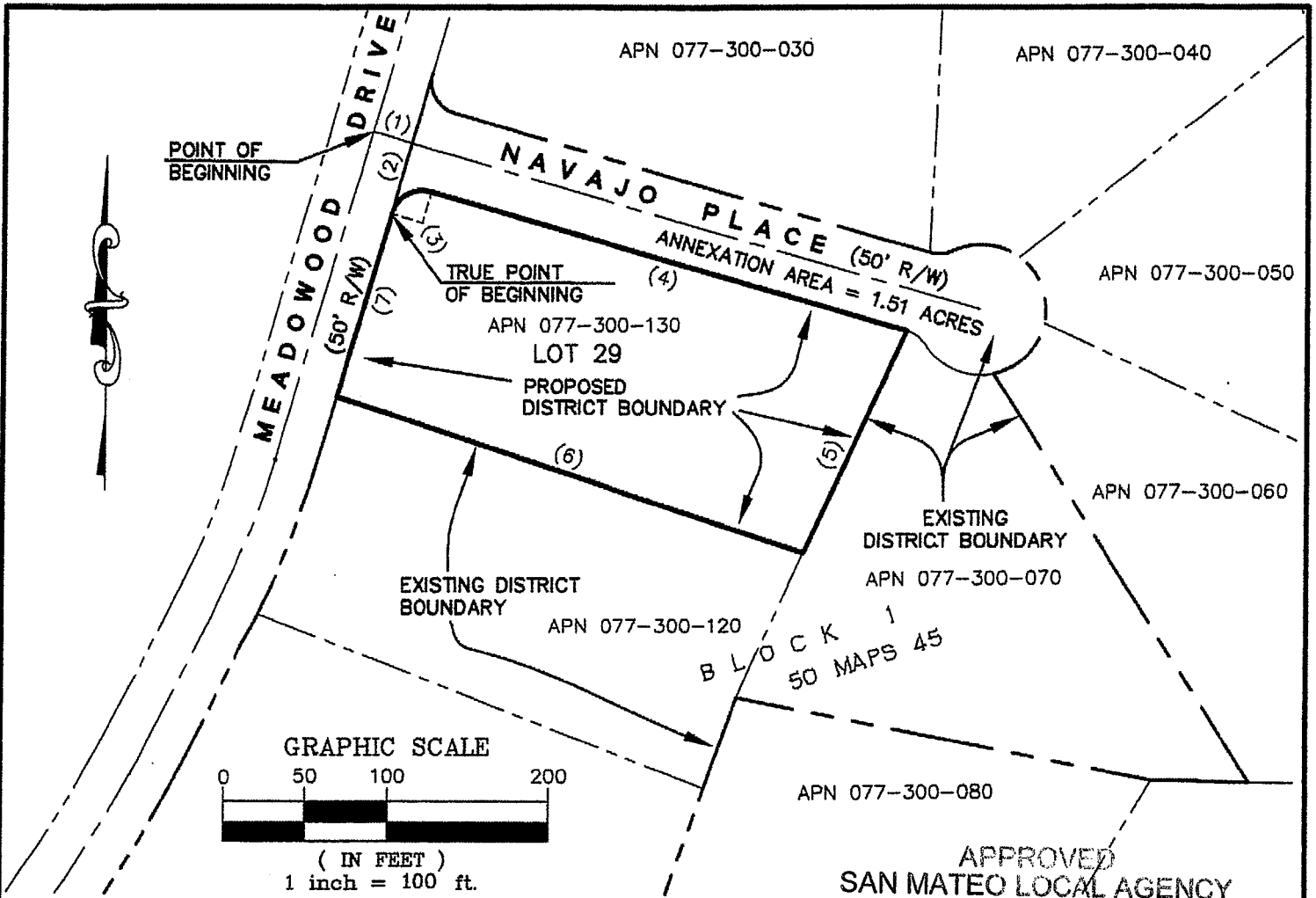

EXHIBIT A PAGE 1 OF 2



**DISCLAIMER:**

FOR ASSESSMENT PURPOSES ONLY. THIS DESCRIPTION OF LAND IS NOT A LEGAL PROPERTY DESCRIPTION AS DEFINED IN THE SUBDIVISION MAP ACT AND MAY NOT BE USED AS THE BASIS FOR AN OFFER FOR SALE OF THE LAND DESCRIBED.

APPROVED  
 SAN MATEO LOCAL AGENCY  
 FORMATION COMMISSION  
 455 COUNTY CENTER  
 REDWOOD CITY, CA 94063

EXHIBIT A PAGE 2 OF 2

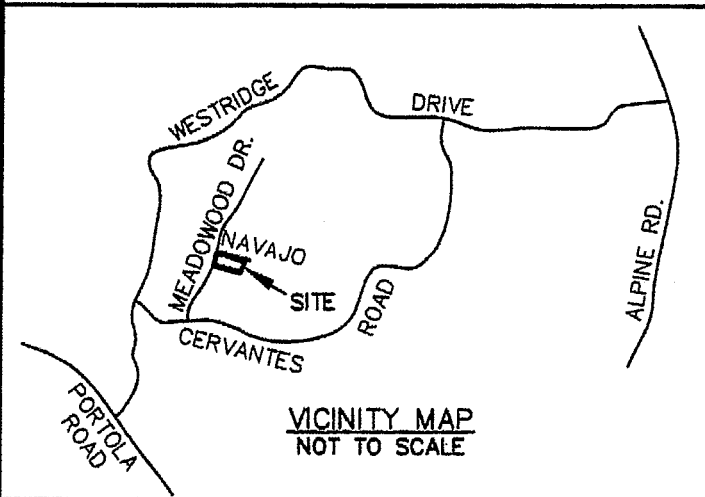

**COURSE**

1	S 73°45'00"	E	25.00'
2	S 16°15'00"	W	45.00'
3	R = 20.00'	CH = 28.28'	Δ = 90°00'00" L = 31.42'
4	S 73°45'00"	E	305.31'
5	S 24°47'01"	W	150.00'
6	N 71°36'25"	W	303.26'
7	N 16°15'00"	E	117.00'

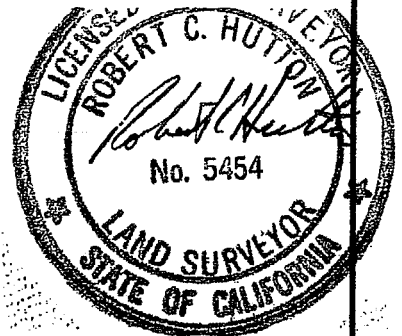

**B & H SURVEYING, INC.** 901 WALTERMIRE ST., BELMONT, CA 94002 (650) 637-1590

TITLE: ANNEXATION OF A PORTION OF THE RANCHO EL CORTE MADERA

TOWN: PORTOLA VALLEY

COUNTY: SAN MATEO COUNTY

CALIFORNIA

SURV: SCALE: 1" = 100'  
 PLAT: RCH DATE: NOVEMBER, 2020

FOR:

JOB NO. 7593-20  
 DWG NO. 7593-ANNEX



WEST BAY SANITARY DISTRICT  
EXHIBIT "B"  
SITE LOCATION  
4 NAVAJO PLACE  
PORTOLA VALLEY, CA  
GRINDER SYSTEM

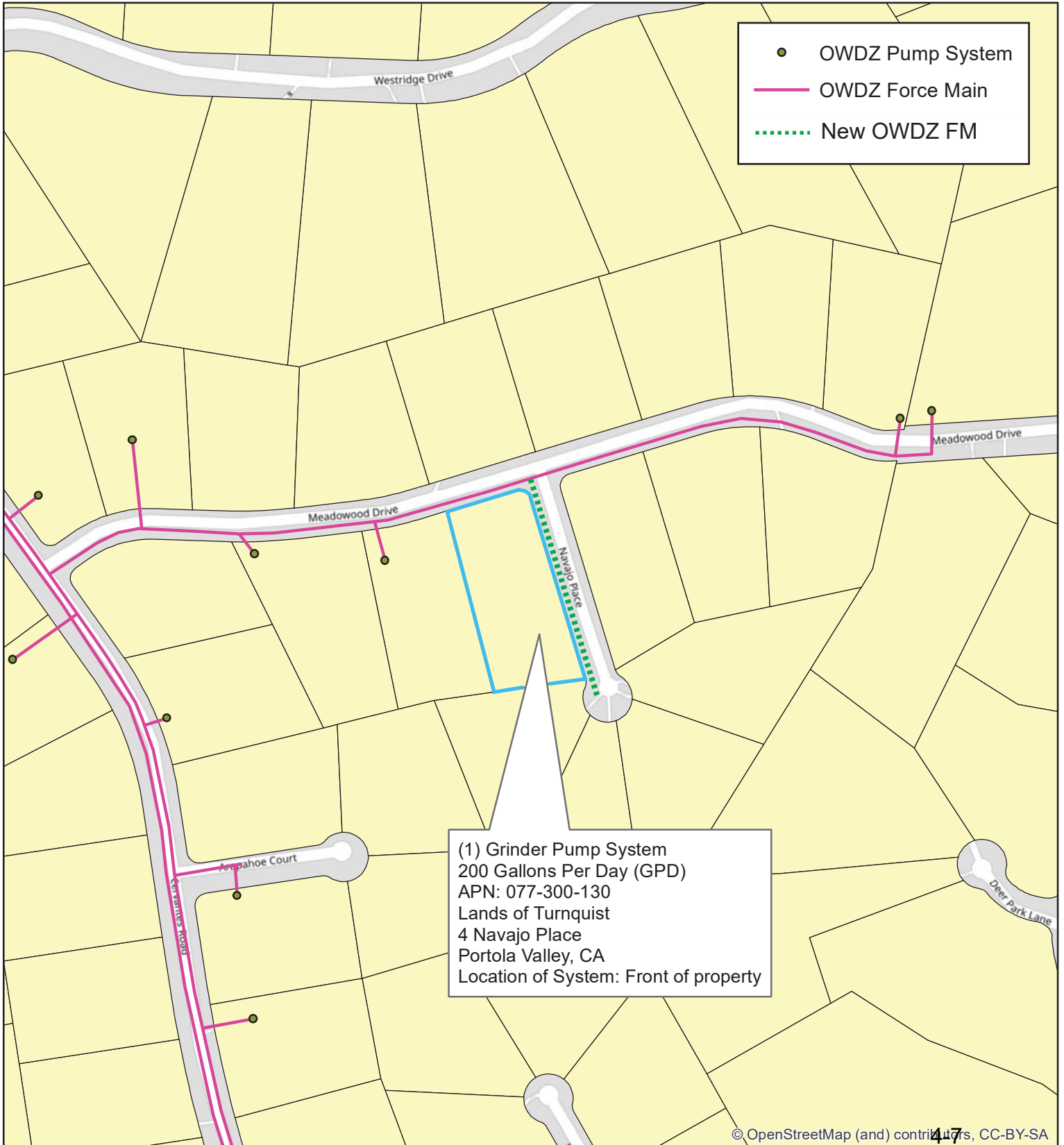

THIS PAGE LEFT INTENTIONALLY BLANK





*1902 - Serving Our Community for over 115 Years - 2021*

**WEST BAY SANITARY DISTRICT  
MINUTES OF THE REGULAR MEETING OF THE DISTRICT BOARD  
WEDNESDAY, MAY 26, 2021 AT 7:00 P.M.**

**1. Call to Order**

President Dehn called the meeting to order at 7:00 PM

**Roll Call**

BOARD MEMBERS PRESENT: President Dehn, Secretary Walker, Treasurer Thiele-Sardiña, Director Moritz, Director Otte

BOARD MEMBERS ABSENT: None.

STAFF MEMBERS PRESENT: Ramirez, Condotti by Zoom, Finance Manager - Debra Fisher, Projects and IT Manager - Bill Kitajima

Others Present:

**2. Communications from the Public: None.**

**3. Consent Calendar**

Motion to Approve by: Thiele-Sardiña 2<sup>nd</sup> by: Moritz Vote: AYE: 5 NAY: 0 Abstain: 0

**CONSIDERATION OF ITEM(S) REMOVED FROM THE CONSENT CALENDAR**

Comments: None.

- A. Approval of Minutes for Special meeting May 5, 2021
- B. Approval of Minutes for Regular meeting May 12, 2021
- C. Consideration of a Resolution of Intention to Annex Certain Territory (20 Sioux Way) to the West Bay Sanitary District On-Site Wastewater Disposal Zone and to Establish the Date and Time of Public Hearing
- D. Consideration of a Resolution of Intention to Annex Certain Territory (155 Grove Drive) to the West Bay Sanitary District On-Site Wastewater Disposal Zone and to Establish the Date and Time of Public Hearing
- E. Bank of the West Monthly Investment Portfolio Statements
- F. Consideration of Resolution Accepting Deed of Easement Pursuant to Class 3 Sewer Permit No. 1102 for the Construction of Wastewater Facilities for 40 Sioux Way, Portola Valley, California
- G. Consideration of Resolution Authorizing the District Manager to Execute Quitclaim Deed of Sanitary Sewer Easement at 27 Sargent Lane, Atherton, California
- H. Consideration of Resolution Accepting Deed of Easement for District Main Sewer Facilities at 27 Sargent Lane, Atherton, California

#### 4. Report on Insurance Market Update & Insurance Renewals FY 2021-22

Comments: Seth Cole with Alliant reported on the District's increased insurance costs for FY 2021-22. Director Otte asked if the deductibles will be going up. Mr. Cole reported the deductibles are not going up but the premiums will go up by 20%. Mr. Cole also reported that property insurance premiums for the District building will be \$17,000/year and SHGCC will increase from \$12,000/year to \$26,300/year. Board consensus was to look at increasing deductibles from \$5K and \$25K to higher limits. The Finance Committee will look at insurance deductible options in order to lower premiums.

#### 5. District Manager's Report

- 1) Comments: District Manager Ramirez reported that LAFCo approved the Municipal Service Review (MSR). Finance Manager Fisher will schedule a meeting with the Finance Committee to review the Reserve Policy. LAIF balances will be discussed in detail during the next Board meeting followed by the consideration of the FY 2021-22 Budget. District Manager Ramirez reported that the County of San Mateo has not been reasonable in coordinating the CIP on Ringwood Ave.
- 2) **Administrative:**
  - a. Personnel Policy has been updated and approved by the Board of Directors at the Regular Board Meeting on May 12, 2021.
  - b. The LAFCo Commission approved the Municipal Service Review between the City of East Palo Alto, East Palo Alto Sanitary District, and West Bay Sanitary District on May 19, 2021.
  - c. The proposed FY21/22 budget will be presented to the Board on June 9, 2021 Regular Board Meeting.
- 3) **Finance:**
  - a. The Finance Manager will report on the Local Agency Investment Fund (LAIF) account at the June 9, 2021 Board Meeting.
  - b. The Finance Advisory Committee will be scheduled to review the Reserve Policy once District Counsel has reviewed the revised draft policy.
  - c. The new Money Market Account has been opened for the WBSD/SHGCC facility funds.
- 4) **CIP & IT Projects:**
  - a. **Levee Improvement Project:**
    - i. Now that the Environmental Impact Review for the Levee Improvement and Bayfront Recycled Water Treatment Facility Project at the Flow Equalization and Resource Recovery Facility (FERRF) has been certified and approved, staff will continue to work on the SRF loan application. The Financial and Technical packet to the application should be approved by the Board in the June timeframe.
    - ii. District Manager will share the presentation to be given at the Society for Ecological Restoration International Conference for the Bayfront Ecotone Levee project. The conference is scheduled virtually and will take place in June 2021.

**b. Construction Capital Improvement Program (CIP)**

- i. Aztec Consultants has mobilized in preparation to build the Metal Storage Building at the Flow Equalization Resource Recovery Facility.
- ii. Precision Pipeline continues to work on this year's CIP project. Staff has been working with San Mateo County to coordinate the work on Ringwood Avenue with the County's resurfacing project. The County has not been reasonable in their coordination efforts. The Projects and IT Manager is working on an alternative plan.
- iii. Freyer & Laureta is working on the Bay Front Improvement projects including the Influent Pump Station.

**5) Operations and Maintenance:**

**a. Collection System:**

- i. Crews have been working on the Town of Woodside's collection system.

**b. Training:**

- i. Safety training has been ongoing with the assistance of a DuALL Safety consultant.

**6) Water Quality:**

**a. Sharon Heights Golf and Country Club (SHGCC):**

- i. The recycled water plant has been operating well. Staff is regularly working with SHGCC staff to better predict their water requirements.

**b. Bayfront Recycled Water Facility (BRWF):**

- i. After approving the EIR, the next step will be to enter into developer agreements with developers in the Bayfront Area. District Counsel is working on the Draft Recycled Water Code to be shared with the City of Menlo Park.

**c. West Bay:**

- i. Staff is evaluating other agencies' Operator in Training programs.

**7) Fleet and Facilities:**

**a. Vehicle Maintenance:**

- i. After reviewing the option to lease a hybrid vehicle, it makes sense to do so and will be proposed in the Budget.

**8) Personnel:**

- i. District Manager is reorganizing a portion of the Admin Staff.

**9) Upcoming Events:**

- a. **Regular Board Meeting:** May 26, 2021
- b. **Next Regular Board meeting:** June 9, 2021

**10) Misc./Action Items from Previous Meeting:**

- a. **West Bay SSOs:** Zero SSOs for April 2021.
- b. **LAH Contract:** LAH had one SSO in April.
- c. **Town of Woodside Contract:** Staff received the amended agreement for FY21/22.
- d. **Revenue:** Late notices have been sent to rate payers who are over 90 days late in paying the Sewer Service Charge for FY20/21. These rate payers are billed manually. To-date the District is owed approximately \$19,000.

**6. Consideration to Approve Resolution Approving Amendment No.8 To The Maintenance Service Agreement Between West Bay Sanitary District And The Town Of Woodside For Sanitary Sewer Maintenance Services And Authorize The District Manager To Execute the Amended Agreement On Behalf Of The District**

Motion to Approve by: Moritz 2<sup>nd</sup> by: Thiele-Sardiña Vote: AYE: 5 NAY: 0 Abstain: 0

Comments: None.

**7. Consideration to Establish Date and Time of Public Hearing to Consider Annual Tax Roll Sewer Service Charge Report for Fiscal Year 2021/2022**

Motion to Approve by: Otte 2<sup>nd</sup> by: Walker Vote: AYE: 5 NAY: 0 Abstain: 0

Comments: None.

**8. May 26<sup>th</sup> Update Report on District Response to Corona Virus**

Comments: District Manager Ramirez reported that according to voluntary data, approximately 70% of West Bay staff have been vaccinated. Staff continues to follow Health Department guidelines.

**9. Report and Discussion on Sharon Heights Recycled Water Plant**

Comments: District Manager Ramirez reported that reserve funds are now in the money market account. He also reported a flow study will be performed for the recycled water facility in order to see if it is feasible to add wastewater flows to the recycled water facility.

**10. Discussion and Direction on Bayfront Recycled Water Project and Status Update**

Comments: District Manager Ramirez reported that District Counsel Condotti is currently working on the recycled water code. The new recycled water facility is estimated at approximately \$53M. Developer agreement will have to reflect the cost of the facility. He also reported the SRF application has been submitted to the State.

**11. Report & Discussion on South Bayside Waste Management Authority (SBWMA)**

Comments: President Dehn reported no meeting was held in May.

**12. Report, Discussion & Direction on Silicon Valley Clean Water (SVCW) and Discussion on SVCW CIP Program and Financing**

Comments: Director Moritz reported on a finance presentation that featured retiring more debt. Director Otte reported the Tunnel Project is on schedule and that a change order for the plant's pump station was approved.

**13. Closed Session**

Entered closed session at 8:45 p.m. Left closed session at 9:41 p.m.

Reportable action: None.

A. PUBLIC EMPLOYEE PERFORMANCE EVALUATION/CONF. WITH LABOR NEGOTIATORS

Agency designated representatives: District Manager/Legal Counsel  
Unrepresented & Exempt employees: Unrepresented & Exempt Staff

B. CONFERENCE WITH LEGAL COUNSEL – EXISTING LITIGATION

(Cal. Govt. Code §54956.9(d))

Name of Case: *1740 Oak Avenue, LP v. West Bay Sanitary District, et al.* – SM CSC  
Case No. 18CIV02183

**14. Consideration to Adopt Resolution Establishing Rates of Pay and Related Compensation Provisions**

Motion to Approve by: \_\_\_\_\_ 2<sup>nd</sup> by: \_\_\_\_\_ Vote: AYE: \_\_\_\_\_ NAY: \_\_\_\_\_ Abstain: \_\_\_\_\_

Comments: Board consensus was to continue this item until the June 9<sup>th</sup> Board meeting.

**15. Comments or Reports from Members of the District Board and Consider Items to be Placed on Future Agenda**

Comments: None.

**16. Adjournment Time:** The meeting was adjourned at 9:43 PM

THIS PAGE LEFT INTENTIONALLY BLANK



**WEST BAY SANITARY DISTRICT**  
**Financial Activity Report**  
**May 2021**

**Date:** *June 9, 2021*

**To:** *Board of Directors*

**From:** *Annette Bergeron, Personnel & Accounting Specialist*  
*Debra Fisher, Finance Manager*

**Subject:** *Approve Monthly Financial Activity Report*

---

**Financial Activity for the month:**

**Receipt Summary:**

Commercial Deposits	89,736.85
Deposits in Transit	56.00
Credit Cards	12,753.86
Wires, ACH, & Transfers	7,683,215.55
<b>Total Receipts</b>	<b><u><u>7,785,762.26</u></u></b>

**Withdrawal Summary**

Total Checks	664,029.68
Total Corp Card	13,225.94
Total Bank Transfers	4,384,425.33
Total Internal Transfers from Checking	
<b>Total Withdrawals</b>	<b><u><u>5,061,680.95</u></u></b>

**Fund**

**Summary by Budget Category**

100	Operations	4,939,171.06
200	Capital	39,094.44
500	SHGCC	83,415.45
	<b>Summary by Fund</b>	<b><u><u>5,061,680.95</u></u></b>

Presented to West Bay Sanitary District Board of Directors for review and approval.

President \_\_\_\_\_

Secretary \_\_\_\_\_

**WEST BAY SANITARY DISTRICT**  
**Receipts & Incoming Transfers**  
**May 1, 2021 through May 31, 2021**

RECEIPT NUMBER	DEPOSIT DATE	DESCRIPTION	AMOUNT
461818	5/4/2021	BG Plumbing: 31 Aliso Way, MP, Permit	290.00
461819	5/4/2021	Benjamin Longmier: 1036 Los Trancos Rd, PV, Inv: 2020/21-039	1,364.76
461820	5/4/2021	Town of Woodside: , Inv: 2020/21-085	15,220.71
461821	5/4/2021	Dwd Properties Lic: 2141 Mills, MP, Permit	8,791.00
461822	5/4/2021	Bayshore Plumbers: 1190 Lemon Ave, MP, Permit	290.00
461823	5/5/2021	K.W. Reeves Association: 163 Ramona Road, PV, Inv: 2020/21-044	682.38
461824	5/5/2021	Ars Rescue Rooter: 281 Greenoaks DR, ATH, Permit	355.00
461825	5/5/2021	Valentine Michael P: 4 Perry Ave, MP, Permit	95.00
461826	5/5/2021	RI Brachett Construction: 812 Woodland Ave, MP, Permit	290.00
461827	5/6/2021	Eps Inc.: 4025 Bohannon Dr, MP, Permit	290.00
461828	5/6/2021	Wizard Plumbing: 51 Winchester Dr, ATH, Permit	290.00
461829	5/7/2021	Latala Homes, Inc.: 1760 Poppy Ave, MP, Permit	170.00
461830	5/7/2021	Michael & Sharon Brugos: 1850 Stanford Ave, MP, Inv: 2020/21-015	682.38
461831	5/7/2021	Robert Allen: 211 Nathorst Ave, PV, Inv: 2020/21-025	682.38
461832	5/7/2021	Carla Carstens: 4135 Alpine Rd, PV, Inv: 2018/19-041	1,432.00
461833	5/10/2021	Midpen Housing Corp: 1345 Willow Rd., MP, Permit	3,400.00
461834	5/10/2021	Bryan Murphy: 234 Park Lane, Ath., Permit	434.33
461835	5/10/2021	Peninsula Custom Homes, Inc: 234 Park Lane, Ath., Permit	170.00
461836	5/10/2021	Wizard Plumbing: 240 Oak Grove Ave, MP, Permit	290.00
461837	5/10/2021	Yaeger Construction: 1709 Croner Ave, MP & 333 Pope Street, MP, Permit	490.00
461838	5/10/2021	EJ Plumbing: 2050 Avy Ave, MP, Permit	290.00
461839	5/10/2021	Peninsula Arts Guild: 949 El Camino Real, MP, Permit	460.00
461840	5/10/2021	Slatery Properties Lic: 143 Lake Rd, PV, Permit	585.00
461841	4/1/2021	Ping Fong/Shannon Gabriel: 165 Atherton Ave, ATH, Permit	574.53
461842	5/12/2021	Crown Plumbing: 1023 Oakland Ave, MP, Permit	290.00
461843	5/12/2021	Bell Plumbing Of San Mateo: 1631 Magnolia Court, MP, Permit	355.00
461844	5/12/2021	Rafael & Leslie Mancera: 2361 Ralmar Ave, EPA, Permit	290.00
461845	5/13/2021	Thomas James Homes: 2043 Ashton Ave, MP: 2060 Oakley Ave, MP: 2084 Manzanita Ave, MP, Perm	870.00
461846	5/14/2021	Art Wang: 9 Hesketh Dr, MP, Permit	290.00
461847	5/14/2021	Teresa Luchsinger: 35 Palmer Ln, PV, Permit	1,312.36
461848	5/17/2021	Yizeng Sun & Sai Zhang: 1051 Menlo Oaks Drive, MP, Permit	170.00
461849	5/17/2021	Woodarn & Curran: , Inv: 2020/21-062	1,700.00
461852	5/18/2021	Bayshore Plumbers: 614 Bay Road, MP, Permit	290.00
461853	5/18/2021	Rashmi Kapur: 1251 Orange Ave, MP, Permit	170.00
461854	5/19/2021	Cal-West Sewer & Drain: 66 Virginia Ln, ATH, Permit	290.00
461855	5/20/2021	Town Of Los Altos Hills: , Inv: 2020/21-086	38,365.95
461856	5/20/2021	Plath & Company: 1245 San Mateo Drive, MP, Permit	170.00
461857	5/21/2021	Bayshore Plumbers: 96 Mount Vernon Ln, ATH, Permit	290.00
461858	5/21/2021	TJC Home Builders, LLC: 760 College Ave. & 420 Laurel Ave., MP, Permit	340.00
461859	5/24/2021	The Pradhan 2019 Living Trust: 2010 Avy Ave, MP, Permit	170.00
461860	5/24/2021	Katherine Hsu: 775 18th Ave, MP, Permit	290.00
461861	5/24/2021	Allianz: Vehicle Deductible Reimbursement	1,999.96
461862	5/24/2021	Scott Kaspick: 815 Berkeley Ave, MP, Permit	8,791.00
461863	5/24/2021	Rebuild Green: 17 Lowery Dr, Ath, Permit	170.00
461864	5/24/2021	Valy Construction, Inc.: 751 Menlo Oaks Dr, MP, Permit	290.00
461865	5/25/2021	Star Rooter & Plumbing: 5 Hesketh Dr, MP, Permit	355.00
461866	5/25/2021	George Salah: 19 Redberry Ridge, PV, Inv: 2020/21-045	1,669.16
461867	5/25/2021	Bell Plumbing Of San Mateo: 1278 Santa Cruz Ave, MP, Permit	355.00
461868	5/25/2021	Ray's at GCC Aka Rays Pub: 4133 Alpine Rd, PV, Inv: 2020/21-047	629.61
461869	5/25/2021	Coho At Stanford University: 4133 Alpine Rd, PV, Inv: 2020/21-048	629.60
461870	5/25/2021	College Restaurants: 4133 Alpine Rd, PV, Inv: 2020/21-049	629.60
461871	5/27/2021	Altas Plumbing & Rooter: 198 Burns Ave, Ath, Permit	290.00
461872	5/27/2021	Elio Calderon: Permit: 419 Oak Grove Ave, MP, Permit	95.00
461873	5/27/2021	Cesar Donofrio: 20 Sioux Way, PV, Permit	3,370.00
<b>Total Deposits</b>			<b>\$102,546.71</b>

**WIRE/ACH TRANSFERS RECEIVED**

461850	5/14/2021	Recology: Franchise Fee 4/2021	8,775.14
461851	5/14/2021	SHGCC: SRF Loan Installment #2 and O&M 5/2021	103,322.42
461882	5/28/2021	San Mateo County: Sewer Service Charges FY 2021-22	2,571,117.99
461883	5/24/2021	LALF: Transfer from LALF Acct.	5,000,000.00

**Total Transfer to BoFw Checking**

**\$7,683,215.55**

**TOTAL DEPOSITS**

**\$7,785,762.26**



**WEST BAY SANITARY DISTRICT**  
**Financial Activity Report**  
**Withdrawals**  
**May 1, 2021 through May 31, 2021**

<b>CHECK</b>	<b>DATE</b>	<b>TO WHOM PAYABLE</b>	<b>PURPOSE</b>	<b>AMOUNT</b>
67748	5/5/2021	AAA Rentals	Pneumatic Hose Rental 4/2021	240.00
67749	5/5/2021	Matheson Tri-Gas, Inc.	Gas 4/2021	55.28
67750	5/5/2021	Airgas Usa, LLC	Acetylene and Oxygen Bottle Replacement 4/2021	273.26
67752	5/5/2021	Alpha Analytical Laboratories	Daily Coliform Samples 4/2021	840.00
67753	5/5/2021	Bay Area Paving Co. Inc.	Void Stall Dated Check	0.00
67754	5/5/2021	California Water Service	Water Service - March/April 2021	26.68
67755	5/5/2021	Wex Bank (Chevron)	Gasoline, Oil & Fuel 4/2021	75.00
67756	5/5/2021	Cintas Corp.	Uniform Cleaning 4/2021	1,485.24
67757	5/5/2021	Navia Benefit Solutions	Flexible Spending Account PR Contributions	766.88
67758	5/5/2021	Franchise Tax Board	Wage Garnishments	325.00
67759	5/5/2021	HF&H Consultants, LLC	HF&H Sewer Service Charges Rate Study FY 2020-21 3/2021	830.00
67760	5/5/2021	Home Depot Credit Services	Tools,Wood, & Misc Supplies 4/2021	212.03
67761	5/5/2021	Kone Pasadena	Elevator Maintenance 5/2021	267.12
67762	5/5/2021	City Of Menlo Park - Water	Water Service - March/April 2021	164.28
67763	5/5/2021	Pacific Gas & Electric	Gas & Electric Service - March/April 2021	16,931.11
67764	5/5/2021	Priority 1 Public Safety	Unit 227: Radio Installation	505.40
67765	5/5/2021	Questyme USA	Server Racks	4,449.96
67766	5/5/2021	County Of San Mateo	Special Assessment Preliminary Data	305.00
67767	5/5/2021	Seekzen Systems	IT Consulting Service 4/2021	475.00
67768	5/5/2021	Sharp Business Systems	Lease for(3) copiers (1st Flr Admin, 2nd Flr Admin & Maint)	1,085.18
67769	5/5/2021	Teletrac Navman Us LTD.	GPS For District Vehicles 4/2021	19.95
67770	5/5/2021	United Rentals (North America)	Shoring Rental & Equipment 4/2021	250.84
67771	5/5/2021	Valley Oil Company	Polish Fuel At Six Pump Stations	2,970.00
67772	5/5/2021	Weco Industries, LLC	Operating Supplies 3/2021	7,357.05
67773	5/12/2021	AAA Rentals	Trailer Rental	1,619.96
67774	5/12/2021	Alpha Analytical Laboratories	Daily Coliform Samples	180.00
67775	5/12/2021	Readyrefresh By Nestle	Water Delivery 4/2021	115.26
67776	5/12/2021	Harbor Ready Mix	Concrete & CDF 2/2021	722.14
67777	5/12/2021	California Water Service	Water Service - 4/2021	1,957.13
67778	5/12/2021	CalPERS Long-Term Care Program	LTC Withholding 5/1/21-5/15/21	35.36
67779	5/12/2021	Du-All Safety, LLC	Safety Contract Fee 4/2021	1,620.00
67780	5/12/2021	Federal Express	FedEx -3/29/21	135.30
67781	5/12/2021	Grainger	Operating Supplies 4/2021	3,696.58
67782	5/12/2021	Hach Company	Meters Maintenance & Reporting	13,275.00
67783	5/12/2021	IEDA	Consulting Fees 5/2021	786.00
67784	5/12/2021	Isac Inc	PCM 100 Controller/Modem 3/2021	2,362.70
67785	5/12/2021	Lynsco Garden Materials, Inc	Mini Mulch Fir Bark Ground Covering 4/2021	272.04
67786	5/12/2021	City Of Menlo Park - Water	Water Service - March/April 2021	92.62
67787	5/12/2021	Occupational Health Centers	Health Screening - 4/27/21	63.00
67788	5/12/2021	Pacific Gas & Electric	Gas & Electric Service - April/March 2021	1,306.26
67789	5/12/2021	Robert J. Scheidt	Reimbursement: Admin's Day Luncheon	77.57
67790	5/12/2021	TPX Communications	District VoIP Phone Service	3,038.81
67791	5/12/2021	Univar Solutions Usa	Sodium Hydroxide (Caustic) for SHGCC / RWF 2/2021	3,969.23
67792	5/12/2021	VAR Technology Finance	Fujitsu fi-7900 Scanner Lease	462.99
67793	5/19/2021	Alpha Analytical Laboratories	Daily Coliform Samples 5/2021	60.00
67794	5/19/2021	Atchison, Barisone & Condotti	Attorney Fees 4/2021	11,191.50
67795	5/19/2021	Bay Area Paving Co. Inc.	Paving After Point Repairs on El Camino Real 2/2021	10,754.00
67796	5/19/2021	California Water Service	Water Service - April/May 2021	89.44
67797	5/19/2021	Comcast	Internet - 2006 Sand Hill Rd 5/15/21-6/14/21	140.06
67798	5/19/2021	Dewey Pest Control	Chemical Services 3/2021	7,578.00
67799	5/19/2021	Federal Express	Fed Ex - 5/10/21	105.83
67800	5/19/2021	Navia Benefit Solutions	Flexible Spending Account PR Contributions	766.88
67801	5/19/2021	Franchise Tax Board	Wage Garnishments	325.00
67802	5/19/2021	Freyer & Laureta	Levee Design, North Bay Road, Bayfront Park, Miscellaneous Eng.	68,211.94
67803	5/19/2021	Grainger	Step Ladder, Detergent, Wire Rope - 4/2021	352.28
67804	5/19/2021	Granite Rock, Inc.	Rehab, Rock, & Asphalt 5/2021	513.52
67805	5/19/2021	City Of Menlo Park - Water	Water Service - April/May 2021	1,142.70
67806	5/19/2021	P&F Distributors	HDPE Parts 5/2021	439.19
67807	5/19/2021	Pacific Gas & Electric	Gas & Electric Service -April/May 2021	484.29
67808	5/19/2021	Paxxo (Usa) Inc	Plastic Bags for Drums 5/3/21	550.06
67809	5/19/2021	Precise Concrete Sawing, Inc.	Flat Saw 5/2021	450.00
67810	5/19/2021	Preferred Alliance	Testing 4/2021	412.20

**WEST BAY SANITARY DISTRICT**  
**Financial Activity Report**  
**Withdrawals**  
**May 1, 2021 through May 31, 2021**

67811	5/19/2021	R.E.P. Nut N Bolt Guy	Parts Washer 4/2021	2,414.43
67812	5/19/2021	Recology Peninsula Services	Recology - SHGCC 2yd Bin 4/2021	249.39
67813	5/19/2021	Red Wing Shoe Store	Safety Shoes 3/2021	623.98
67814	5/19/2021	City Of Redwood City	Vehicle Inspections & Repairs	3,746.72
67815	5/19/2021	County Of San Mateo	LSSA Recording Fee: 281 Greenoaks, APN: 061-083-040	20.00
67816	5/19/2021	County Of San Mateo	LSSA Recording Fee: 1631 Magnolia, APN: 071-180-650	23.00
67817	5/19/2021	Seekzen Systems	Anti-spam service for up to 100 users per month 3/2021	720.00
67818	5/19/2021	Sonsray Machinery LLC	Backhoe Repair, DEF Sensor 4/2021	2,519.06
67819	5/19/2021	Staples Credit Plan	Office Supplies - April 2021	925.60
67820	5/19/2021	State Water Resources Control	Wastewater License Renewal	150.00
67821	5/19/2021	Teamsters Local No. 350	Union Dues - 6/2021	976.00
67822	5/19/2021	Towne Ford Sales	Unit 207: Warranty Work & Routine Maintenance	82.86
67823	5/19/2021	Verizon Wireless	District Cellphone 4/16/21-5/15/21	1,165.06
67824	5/19/2021	Vision Communications Co.	Radio Repair 9/2020	68.50
67825	5/19/2021	Young'S Auto Supply Center	Batteries for 217 4/2021	387.66
67826	5/26/2021	AT&T	Telemetry & Alarms 4/13/21-5/12/21	1,059.39
67827	5/26/2021	Alpha Analytical Laboratories	Daily Coliform Samples 4/2021	325.00
67828	5/26/2021	Readyrefresh By Nestle	Water Delivery 4/11/21-5/10/21	245.58
67829	5/26/2021	CWEA	CWEA Certification Renewal R.Sandoval	91.00
67830	5/26/2021	California Water Service	Water Service - April/May 2021	48.90
67831	5/26/2021	CalPERS Long-Term Care Program	LTC Withholding 5/16/21-5/31/21	35.36
67832	5/26/2021	Cintas Corp.	Uniform Cleaning 5/12/21	1,558.73
67833	5/26/2021	Comcast	Internet - 2900 Sand Hill Rd 5/18/21-6/17/21	543.02
67834	5/26/2021	Hf&H Consultants, LLC	HF&H Sewer Service Charges Rate Study FY 2020-21 4/2021	2,284.00
67835	5/26/2021	Menlo Park Historical Assn.	WBSD Membership to Menlo Park Historical Association	100.00
67836	5/26/2021	Pacific Gas & Electric	Gas & Electric Service - Portola Rd 4/19/21-5/17/21	1,476.93
67837	5/26/2021	Albert Patino	Tuition Reimbursement	114.55
67838	5/26/2021	Principal Life Insurance Co.	Insurance 6/2021	6,529.08
67839	5/26/2021	Priority 1 Public Safety	Unit 217: Installation of Safety Equipment 5/2021	4,281.63
67840	5/26/2021	Roberts & Brune Company	Couplers, Traffic Box & Sewer Lid 5/2021	846.04
67841	5/26/2021	Rupert Sandoval	Tuition Reimbursement	119.55
67842	5/26/2021	County Of San Mateo	LSSA Recording Fee: 5 Hesketh Dr, MP; APN: 071-031-190	20.00
67843	5/26/2021	County Of San Mateo	LSSA Recording Fee: 1278 Santa Cruz Ave, 071-051-180	23.00
67844	5/26/2021	Teletrac Navman Us LTD.	GPS For District Vehicles 5/2021	269.22
67845	5/26/2021	Woodard & Curran	Bayfront Recycled Water Project Clean Water SRF Application	13,391.75
67846-67857	5/26/2021	Property Owners/Developers	Reimbursement Agreements: Buja, Westridge, Winchell	407,295.52
67858-67875	5/27/2021	Property Owners/Developers	Reimbursement Agreements: Andrightto, Boyce	30,034.07
				<b>664,029.68</b>

**Corporate Cards:**

GL	DATE	Account Number & Name	Description	Amount
54028	5/25/2021	Commuter Benefits	Fastrak: Transportation Expenses	1,030.00
54075	5/25/2021	District Manager - Bond	DM Meetings	70.08
54080	5/25/2021	Memberships	CWEA Membership Fees	210.00
54091	5/25/2021	Stationary and Office Supplies	Office Supplies	398.56
54101	5/25/2021	Ops Supplies & Materials	Traffic Control Signs, Equipment Repairs	2,521.47
54103	5/25/2021	Vehicle & Equipment Supplies	Service Maintenance, Vehicle Accessories	1,357.67
54128	5/25/2021	Misc Professional Services	Video of SHGCC-RWF for State Inspection	2,500.00
54154	5/25/2021	Mobile & Non-mobile Equip R&M	Alarm System	1,237.00
54156	5/25/2021	Landscaping	Plants	20.94
54157	5/25/2021	Building Repairs & Maint.	SHGCC-RWF: Chlorine Strips	307.01
54174	5/25/2021	Mgmt Conf. & District Meetings	Admin Day Luncheon, Business Meetings	467.34
54175	5/25/2021	CWEA Conf/Section Mtgs	CWEA Prep Class	127.26
54203	5/25/2021	Licenses & Permits	SMCO Permit	760.14
54207	5/25/2021	Vallombrosa Center	Vallombrosa: On Call Lodging	1,890.00
54158	5/25/2021	Computer Software R & M	Log Me In, Zoom & Norton: Monthly Subscriptions	244.54
54159	5/25/2021	Computer Hardware R & M	Keyboards & Mouse Replacements	83.93
<b>Bank of the West - Credit Cards</b>				<b>13,225.94</b>

**WEST BAY SANITARY DISTRICT**  
**Financial Activity Report**  
**Withdrawals**  
**May 1, 2021 through May 31, 2021**

**Bank Transfers:**

<b>DATE</b>	<b>TO WHOM PAYABLE</b>	<b>PURPOSE</b>	<b>AMOUNT</b>
5/3/2021	Paytrace	Credit Card Processing Fees	1,000.77
5/5/2021	SVCW	Monthly Operating Contribution	636,710.00
5/7/2021	PrimePay	PrimePay Fees	656.75
5/7/2021	PrimePay	Employee Payroll & Board of Director Fees - Check Date: 5/7/2021	115,545.79
5/7/2021	PrimePay	Payroll Taxes	34,603.60
5/7/2021	ICMA	Deferred Compensation	12,228.26
5/11/2021	CalPERS	Health Premiums	55,124.48
5/17/2021	CalPERS	Retirement - 4/2021	47,134.24
5/20/2021	Bank of the West	Bank Fees	462.70
5/21/2021	PrimePay	Employee Payroll - Check Date: 5/21/2021	112,418.42
5/21/2021	PrimePay	Payroll Taxes	33,558.98
5/21/2021	ICMA	Deferred Compensation	10,328.26
5/24/2021	NeoPost	Postage	300.00
5/26/2021	CalPERS	Unfunded Accrued Liability	3,277,209.00
5/28/2021	CalPERS	Retirement - 5/2021	47,144.08
<b>Bank Transfers From Bofw Checking</b>			<b><u>4,384,425.33</u></b>

**Summaries:**

**Withdrawal Summary**

Total Checks	664,029.68
Total Corp Card	13,225.94
Total Bank Transfers	4,384,425.33
<b>Total Withdrawals</b>	<b><u>5,061,680.95</u></b>

**Fund Summary by Budget Category**

100	Operations	4,939,171.06
200	Capital	39,094.44
500	SHGCC	83,415.45
		<b><u>5,061,680.95</u></b>

**WEST BAY SANITARY DISTRICT**  
**Financial Activity Report**  
**Supplemental Purchase Register**  
**May 1, 2021 through May 31, 2021**

**OPERATING SUPPLIES & OFFICE EXPENSE**

<u>CHECK</u>	<u>DATE</u>	<u>VENDOR</u>	<u>DESCRIPTION</u>	<u>AMOUNT</u>
67765	5/5/2021	QUESTYME USA	Server Racks	4,449.96
67772	5/5/2021	WECO INDUSTRIES, LLC	Hoses, Manhole Hooks, Root Saw Blades, Spanner Wrench, & CCTV Repairs	7,357.05
67773	5/12/2021	AAA RENTALS	Trailer Rental	1,619.96
67781	5/12/2021	GRAINGER	Water Filter, Utensils, Trash Bags, Disposable Respirator, Gloves, Face Masks	3,696.58
67791	5/12/2021	UNIVAR SOLUTIONS USA	Sodium Hydroxide (Caustic) for SHGCC / RWF 2/2021	3,969.23
67811	5/19/2021	R.E.P. NUT N BOLT GUY	Parts Washer 4/2021	2,414.43
67784	5/12/2021	ISAC INC	PCM 100 Controller/Modem 3/2021	2,362.70
67791	5/12/2021	UNIVAR SOLUTIONS USA	Sodium Hydroxide (Caustic) for SHGCC / RWF 2/2021	3,969.23
67811	5/19/2021	R.E.P. NUT N BOLT GUY	Parts Washer 4/2021	2,414.43
67818	5/19/2021	SONSRAY MACHINERY LLC	Backhoe Repair, DEF Sensor 4/2021	2,519.06
67839	5/26/2021	PRIORITY 1 PUBLIC SAFETY	Unit 217: Installation of Safety Equipment 5/2021	4,281.63

**MISCELLANEOUS**

<u>CHECK</u>	<u>DATE</u>	<u>VENDOR</u>	<u>DESCRIPTION</u>	<u>AMOUNT</u>
67753	5/5/2021	BAY AREA PAVING CO. INC.	Paving After Repairs on Mainline	10,754.00
67753	5/19/2021	BAY AREA PAVING CO. INC.	Void Stall Dated Check	(10,754.00)
67771	5/5/2021	VALLEY OIL COMPANY	Polish Fuel At Six Pump Stations	2,970.00
67782	5/12/2021	HACH COMPANY	HACH 27 Meters Maint & Reporting Contract	13,275.00
67795	5/19/2021	BAY AREA PAVING CO. INC.	Paving After Point Repairs on El Camino Real 2/2021	10,754.00
67798	5/19/2021	DEWEY PEST CONTROL	Chemical Services 3/2021	7,578.00
67802	5/19/2021	FREYER & LAURETA	Levee Design, North Bay Road, Bayfront Park, Miscellaneous Eng.	68,211.94
67814	5/19/2021	CITY OF REDWOOD CITY	Vehicle Inspections & Repairs	3,746.72
67818	5/19/2021	SONSRAY MACHINERY LLC	Backhoe Repair, DEF Sensor 4/2021	2,519.06
67795	5/19/2021	BAY AREA PAVING CO. INC.	Paving After Point Repairs on El Camino Real 2/2021	10,754.00
67798	5/19/2021	DEWEY PEST CONTROL	Chemical Services 3/2021	7,578.00
67802	5/19/2021	FREYER & LAURETA	Levee Design, North Bay Road, Bayfront Park, Miscellaneous Eng.	68,211.94
67814	5/19/2021	CITY OF REDWOOD CITY	Glass Replacement, Routine Maintenance, Vehicle Inspections & Repairs	3,746.72
67834	5/26/2021	HF&H CONSULTANTS, LLC	HF&H Sewer Service Charges Rate Study FY 2020-21 4/2021	2,284.00
67837	5/26/2021	ALBERT PATINO	Office of Water Programs - Operation of Wastewater Plants	114.55
67841	5/26/2021	RUPERT SANDOVAL	Office of Water Programs - Advanced Waste Treatment	119.55
67845	5/26/2021	WOODARD & CURRAN	Bayfront Recycled Water Project Clean Water SRF Application	13,391.75
67846-67857	5/26/2021	Property Owners/Developers	Reimbursement Agreements: Buja, Westridge, Winchell	407,295.52
67858-67875	5/27/2021	Property Owners/Developers	Reimbursement Agreements: Andrighetto, Boyce	29,307.84

**WEST BAY SANITARY DISTRICT**  
**Expenditures Summary FY 2020-21**  
**7/01/2020 to 05/31/2021**

<b>REGULAR PAYABLES</b>	<b>TOTAL BY VENDOR YTD FY 2020-21</b>	<b>WITHDRAWALS 5/2021</b>
3T Equipment Company	25,952.65	-
A-A Lock & Alarm	814.40	-
AAA Rentals	4,923.32	1,859.96
A & B Trailer Hitch Inc.	393.98	-
Abila	13,491.28	-
Access	190.00	-
Ace Fire Equipment & Service	1,306.05	-
Action Towing	1,437.00	-
Airgas Usa, LLC	273.26	273.26
Air & Lube Systems, Inc.	52,759.21	-
All Fence Company, Inc.	1,040.00	-
Alliant Insurance Services	18,817.00	-
Allied Crane	560.84	-
The Almanac	6,864.00	-
Alpha Analytical Laboratories	11,055.00	1,405.00
Angel Ambriz	83.00	-
American Messaging	203.66	-
American Textile & Supply	1,959.58	-
Anderson Pacific	901,235.40	-
Aquality Water Management Inc.	695.14	-
Aqua Natural Solutions	4,009.20	-
Arcon Builders	2,000.00	-
AT&T	11,351.45	1,059.39
Atchison, Barisone & Condotti	73,096.16	11,191.50
Backflow Prevention Specialist	1,913.00	-
Bank of the West - Credit Cards	159,557.22	13,225.94
Bank of the West	4,677.98	462.70
Barker Wagoner Architects	15,038.60	-
Battery Junction Wholesale	441.12	-
Bay Alarm	17,837.53	-
Bay Area Air Quality Mgmt Dist	7,659.00	-
Bay Area Barricade Service Inc	629.67	-
Bay Area Paving Co. Inc.	10,754.00	10,754.00
Bayside Equipment Company	29,503.36	-
Annette Bergeron - Petty Cash	143.43	-
Jed M. Beyer	2,730.00	-
Bonny Doon Environmental	4,358.68	-
Vance Brown	291.25	-
California Water Service	19,741.67	2,122.15
CalPERS - Actuary Fee	1,050.00	-
CalPERS - Unfunded Accrued Liability	1,982,655.00	3,277,209.00
CalPERS - Retirement	629,839.26	94,278.32
CalPERS - Health Premiums	514,709.02	55,124.48
Calpers Long-Term Care Program	777.92	70.72
CASA	13,600.00	-
CDW Government	7,866.59	-
Center for Hearing Health Inc.	600.00	-
Chavan & Associates LLP	14,000.00	-
Chemsearch	1,590.19	-
George Choi	9,500.00	-
Cintas Corp.	38,388.84	3,043.97
City of Menlo Park	552.00	-
City of Menlo Park - Repair	10,190.30	-
City of Menlo Park-Fuel	33,711.91	-
City of Menlo Park - Water	14,825.87	1,399.60
Comcast	5,138.07	683.08
The Concept Genie	1,326.16	-
Consolidated Parts, Inc	1,197.30	-
Costco Membership	60.00	-
Heath Cortez	225.00	-
CPS HR Consulting	7,627.50	-
CSDA	7,805.00	-
CSRMA c/o Alliant Insurance	333,398.60	-
CUSI	13,750.00	-
CWEA	2,085.00	91.00
Cues, Inc.	3,950.00	-
Custom Lanyard	1,619.40	-
Dell Marketing L.P.	1,679.20	-
Deluxe	422.64	-
Dewey Pest Control	16,363.00	7,578.00
Ditch Witch West	1,610.14	-
D & L Supply	391.54	-
Dolphin Graphics	17,039.74	-
Du-All Safety, Llc	18,798.75	1,620.00
Duke's Root Control, Inc	153,327.92	-
ESRI	12,125.00	-
East Bay Muni Utility District	2,458.50	-
Elite Parts LLC	7,838.31	-
Embarcadero Media	4,721.20	-
Emerging Sun Productions	436.00	-
Envirozyme	3,074.82	-
Fast Response On-Site Testing	1,817.60	-
Federal Express	2,720.23	241.13
Fremont Urgent Care	2,838.00	-
Finishmaster Inc	1,098.92	-

**WEST BAY SANITARY DISTRICT**  
**Expenditures Summary FY 2020-21**  
**7/01/2020 to 05/31/2021**

<b>REGULAR PAYABLES</b>	<b>TOTAL BY VENDOR</b>	<b>WITHDRAWALS</b>
	<b>YTD FY 2020-21</b>	<b>5/2021</b>
City of Foster City	1,520.00	-
Franchise Tax Board	6,000.00	650.00
Freyer & Laureta	637,124.87	68,211.94
Global Equipment, Inc	2,671.26	-
Golden Gate Truck Center	2,219.47	-
Goldstreet Design Agency, Inc.	844.38	-
GovernmentJobs.com dba NeoGov	3,778.32	-
GovConnection, Inc.	780.00	-
Grainger	42,748.72	4,048.86
Granite Rock, Inc.	1,194.71	513.52
Hach Company	58,160.72	13,275.00
Hadronex, Inc.	34,632.00	-
Harben California	5,662.48	-
Harbor Ready Mix	1,250.93	722.14
Harrington Industrial Plastics	131.02	-
Helix Laboratories, Inc.	2,403.50	-
HF&H Consultants, LLC	61,928.60	3,114.00
Arthur Hildebrand	249.00	-
Hillyard/San Francisco	1,738.23	-
Home Depot Credit Services	10,826.37	212.03
Bob Hulsmann	1,715.36	-
ICMA	266,917.28	22,556.52
IEDA	8,646.00	786.00
ISAC Inc	3,862.70	2,362.70
Innovyze, Inc	8,194.00	-
Institute for Local Government	350.00	-
Instrument Technology Corp.	8,891.26	-
Intl Training & Rehab Tech Inc	950.00	-
Interstate Traffic Control	172.07	-
Jani-King of CA, Inc - SFR/OAK	9,414.33	-
Jason Kambic	6,440.00	-
Kantor's Furniture	6,610.63	-
Kimball Midwest	9,133.77	-
KIS	14,499.17	-
Kone Pasadena	2,938.32	267.12
Lasky Trade Printing	426.08	-
Learn It Inc.	1,500.00	-
Log Me In	1,801.98	-
Lyngso Garden Materials, Inc	272.04	272.04
Machu Picchu Roofing	3,000.00	-
Damian Madrigal	295.00	-
Eric Madrigal	169.10	-
Mallory Co.	12,298.39	-
Matheson Tri-Gas, Inc.	599.31	55.28
Shahriyar Matloub	460.00	-
Medina's Catering	778.28	-
Meineke	1,580.76	-
Menlo Chevron	790.56	-
Menlo Park Chamber of Commerce	475.00	-
Menlo Park Fire Protection	8,290.00	-
Menlo Park Hardware Co. #14016	882.09	-
Menlo Park Historical Assn.	100.00	100.00
Mid Peninsula Abstracts	553.33	-
Mid State Container Sales, Inc	2,800.00	-
Mission Clay Products, LLC	8,111.70	-
Mission Valley Ford	1,074.25	-
Justin Morin	1,561.10	-
Morse Hydraulics	1,930.45	-
Motion Industries, Inc.	390.95	-
Municipal Maintenance Equip.	31,180.19	-
National Auto Fleet Club	87,289.71	-
Navia Benefit Solutions	14,775.80	1,533.76
NeoPost	2,450.00	300.00
Carrie Nevoli - Petty Cash	598.06	-
Nixon-Egli Equipment Company	6,921.23	-
North Bay Pensions	2,500.00	-
R.A. Nosek Investigations	2,940.00	-
Occasions, ETC.	514.96	-
Occupational Health Centers	1,591.00	63.00
Ogasawara Landscape Maint.	9,670.00	-
Omega Industrial Supply, Inc.	11,677.90	-
P&F Distributors	7,623.60	439.19
Pacific Gas & Electric	202,502.98	20,198.59
Partridge, LLC	8,501.00	-
Albert Patino	339.55	114.55
Paxxo (USA) Inc	550.06	550.06
Paytrace	6,980.56	1,000.77
Peninsula Battery Inc.	1,978.12	-
Peninsula Building Supply	3,080.32	-
Pier 2 Marketing	2,300.00	-
Ponton Industries, Inc.	19,948.58	-
Precise Concrete Sawing, Inc.	1,300.00	450.00
Precise Printing and Mailing	12,204.73	-
Precision Engineering	279,733.20	-
Preferred Alliance	3,239.22	412.20

**WEST BAY SANITARY DISTRICT**  
**Expenditures Summary FY 2020-21**  
**7/01/2020 to 05/31/2021**

<b>REGULAR PAYABLES</b>	<b>TOTAL BY VENDOR YTD FY 2020-21</b>	<b>WITHDRAWALS 5/2021</b>
PrimePay Fees	8,496.07	656.75
Principal Life Insurance Co.	60,586.12	6,529.08
Priority 1 Public Safety	12,695.99	4,787.03
Property Owners/Developers	437,329.59	437,329.59
Quadient Leasing USA, Inc.	536.50	-
Questyme USA	4,449.96	4,449.96
Jose Quezada	1,525.79	-
R.E.P. Nut N Bolt Guy	2,414.43	2,414.43
Sergio Ramirez	13,661.69	-
Ranger Pipelines	39,646.99	-
Readyrefresh By Nestle	3,828.71	360.84
Recology Peninsula Services	810.52	249.39
Red Wing Shoe Store	6,785.62	623.98
City of Redwood City	11,392.53	3,746.72
Redwood General Tire Co., Inc.	507.11	-
Registrar of Voters	4.37	-
Todd Reese	500.00	-
Resolution Gutter	760.00	-
Rich Voss Trucking	986.00	-
Roadrunner Glass Door, Inc.	4,781.88	-
Roberts & Brune Company	24,123.81	846.04
SVCW Bond - 2014 Bond	1,145,479.63	-
SVCW Bond - 2015 Bond	1,610,500.00	-
SVCW Bond - 2018 Bond	1,837,712.50	-
SVCW - Monthly Operating Payment	6,367,100.00	636,710.00
SVCW - SRF Loan	506,765.21	-
Silicon Valley Clean Water	525.00	-
Safety Kleen Corp.	2,771.66	-
County of San Mateo	1,663.00	391.00
San Mateo County Tax Collector	945.58	-
San Mateo County Health	3,894.00	-
County of San Mateo - LAFCO	28,067.00	-
County of Santa Clara	587.00	-
Rupert Sandoval	238.10	119.55
Henry Santos	150.00	-
Robert J. Scheidt	1,573.96	77.57
Phil Scott	75.61	-
Seekzen Systems	10,347.80	1,195.00
Shape Incorporated	11,852.53	-
Sharp Business Systems	13,293.17	1,085.18
Sharp Electronics Corporation	288.59	-
Snap On Industrial	1,550.79	-
Siemens Industry, Inc.	10,199.58	-
Signa Mechanical	16,270.26	-
Sonsray Machinery LLC	4,659.57	2,519.06
Spartan Tool, LLC	5,023.20	-
Staples Credit Plan	11,050.37	925.60
State Water Resources Control	27,869.50	150.00
Steven Creek Quarry, Inc.	1,998.41	-
Robert Stone	9,986.16	-
Summit Aerial Services Inc	1,000.00	-
Sunstate Equipment	3,653.29	-
The Surtec System	219.33	-
Sutter EAP	1,657.75	-
Syneco Systems, Inc.	381.00	-
SWRCB - SHRWF SRF Loan	662,910.88	-
TPX Communications	14,683.79	3,038.81
Target Specialty Products	2,219.79	-
Teamsters Local No. 350	11,798.00	976.00
Teletrac Navman US Ltd.	2,377.50	289.17
Town of Atherton	3,000.00	-
Towne Ford Sales	67,408.98	82.86
Tritech Software Systems	990.00	-
Underground Service Alert	9,225.73	-
United Rentals (North America)	250.84	250.84
Univar Solutions USA	3,969.23	3,969.23
Urbanowicz, John H.	8,000.00	-
USA Blue Book	428.36	-
U.S. Jetting, LLC.	1,049.76	-
VAR Technology Finance	3,258.77	462.99
V & A Consulting Engineers	10,165.00	-
Valley Heating & Cooling	3,683.00	-
Valley Oil Company	3,070.02	2,970.00
Veolia Water North America	159.73	-
Verizon Wireless	6,239.90	1,165.06
Vision Communications Co.	8,824.54	68.50
Weco Industries, LLC	50,392.17	7,357.05
Western States Tool & Supply	3,283.63	-
Western Truck Fab	1,180.92	-
Wex Bank (Chevron)	1,623.27	75.00
Woodard & Curran	73,683.68	13,391.75
Young's Auto Supply Center	1,392.58	387.66
Zanker Recycling	51.77	-
<b>TOTAL REGULAR PAYABLES</b>	<b>20,538,214.21</b>	<b>4,765,554.16</b>

**WEST BAY SANITARY DISTRICT**  
**Expenditures Summary FY 2020-21**  
**7/01/2020 to 05/31/2021**

<b>REGULAR PAYABLES</b>	<b>TOTAL BY VENDOR</b>	<b>WITHDRAWALS</b>
	<b>YTD FY 2020-21</b>	<b>5/2021</b>
<b><u>SALARIES, WAGES &amp; WITHHOLDINGS</u></b>		
Salaries/Wages - Net Pay	2,414,900.22	223,884.21
Directors Fees - Net Pay	31,713.49	4,080.00
Payroll Taxes	750,500.18	68,162.58
Performance Merit Program - Net Pay	130,427.78	-
<b>TOTAL SALARIES RELATED</b>	<b><u>3,327,541.67</u></b>	<b><u>296,126.79</u></b>
<b>TOTAL WITHDRAWALS</b>	<b><u>23,865,755.88</u></b>	<b><u>5,061,680.95</u></b>
<b>WBSD Transfers:</b>		
Transfer to WBSD LAIF Account	10,500,000.00	-
Transfer to WBSD Investment Accounts	2,799,000.00	-
Other Transfers	-	-
<b>Transfer to WBSD Accounts</b>	<b><u>13,299,000.00</u></b>	<b><u>-</u></b>





**WEST BAY SANITARY DISTRICT  
AGENDA ITEM 5C**

**To: Board of Directors**

**From: Bob Hulsmann, Operations Superintendent**

**Subject: WBSD Operations and Maintenance Report – May 2021**

Month	Basin PM Pipe Clean- ing	High Freq. PM Pipe Clean- ing	Un- Sche. Pipe Clean- ing	WBSD CCTV Insp.	Pipe Patch Repairs	Open Trench Repairs	Pump Sta. PM	Pump Sta. Unsch. Repairs	SSO	SSO	Service Calls- Unit 208			
	Miles	Miles	Miles	Miles	Qty.	Qty.	Qty.	Qty.	Cat. 1	Cat. 2&3s	Call Outs	Sch PM	Unsch. PM	USA's
January	11.4	4.7	1.2	2.7	5	5	61	0	0	0	79	12	0	153
February	4.6	7.1	0.5	2.9	5	8	66	0	0	0	68	5	0	190
March	16.8	0.1	0.4	4.8	2	8	73	0	0	0	87	14	0	230
April	9.9	5.0	0.1	0.8	5	8	79	0	0	0	76	9	0	195
May	10.7	9.7	0.3	1.1	4	8	70	0	0	0	74	11	0	213
<b>Yr to date</b>	<b>53.4</b>	<b>26.6</b>	<b>2.5</b>	<b>12.3</b>	<b>21</b>	<b>37</b>	<b>349</b>	<b>0</b>	<b>0</b>	<b>0</b>	<b>384</b>	<b>51</b>	<b>0</b>	<b>981</b>
<b>2021 Goals</b>	<b>120.0</b>	<b>50.0</b>	<b>n/a</b>	<b>45-50</b>	<b>65</b>	<b>90</b>	<b>n/a</b>	<b>&lt;10</b>	<b>0-2</b>	<b>3 to 5</b>	<b>n/a</b>	<b>n/a</b>	<b>n/a</b>	<b>n/a</b>
2020 Results	134.2	51.0	8.4	29.6	72	85	754	6	0	0-Jan	1012	89	5	2362
2019 Goals	112.0	48.2	6.9	42.7	60	86	967	6	0	4	1063	75	33	2850
2018 Results	134.2	48.5	7.4	42.1	66	63	1256	6	0	4	1139	134	89	2525
2017 Results	126.4	51.5	5.7	24.8	66	97	1265	8	2	3	700	178	61	3218
2016 Results	126.4	49	6	33	65	94	1188	5	0	8	798	167	155	3222
2015Results	126.4	55	21	46	65	90	1349	6	0	5	798	174	185	2125
2014Results	126.4	63	20	48	65	78	1328	10	2	12	771	183	72	1834

THIS PAGE LEFT INTENTIONALLY BLANK



**WEST BAY SANITARY DISTRICT  
AGENDA ITEM 5D**

**To: Board of Directors**

**From: Bob Hulsmann, Operations Superintendent**

**Subject: Town of Los Altos Hills - Operations and Maintenance Report for Work Performed by WBSD – May 2021**

	Basin PM Pipe Clean- ing	High Freq. PM Pipe Clean- ing	Un- Sche. Pipe Clean- ing	WBSD CCTV Insp.	Pump Sta. PM	Pump Sta. Unsch. Repairs	SSO	SSO	Service Calls
Month							Cat. 1	Cat. 2&3s	Call Outs
Temp Help	Miles	Miles	Miles	Miles	Qty.	Qty.			
January	1.2	1.3	0.0	0.0	4	0	0	0	0
February	1.7	0.2	0.0	1.3	4	0	0	0	1
March	1.4	1.2	0.0	1.5	4	0	0	0	0
April	1.0	1.6	0.1	0.9	4	0	0	1	0
May	0.1	2.1	0.0	1.2	4	0	0	0	0
June									
July									
*August	1.8	1.1	0.4	1.0	4	0	0	1	0
Sept.	1.8	0.5	0.0	1.9	4	0	0	0	0
Oct.	1.7	0.8	0.0	0.8	4	0	0	0	0
Nov.	1.1	0.2	2.1	0.0	4	0	0	0	0
Dec	1.3	1.5	0.5	0.9	4	0	0	0	0
<b>** Yr to date</b>	<b>13.1</b>	<b>10.5</b>	<b>3.1</b>	<b>9.5</b>	<b>40</b>	<b>0</b>	<b>0</b>	<b>2</b>	<b>1</b>
FY20/21Goals	17.4	16.9	n/a	9.3	52	n/a	n/a	n/a	n/a

\* = August- Start of Contract  
1.\*\* = Lucity Data

THIS PAGE LEFT INTENTIONALLY BLANK



**WEST BAY SANITARY DISTRICT  
AGENDA ITEM 5E**

**To: Board of Directors**

**From: Bob Hulsmann, Operations Superintendent**

**Subject: Town of Woodside Operations and Maintenance Report for Work  
Performed by WBSD – May 2021**

---

Please see next page for work performed.

\*= July Start of Contract. Data shows 2020/2021 PMPP year.



## Yearly Summary Report

6/3/2021

8:48 AM

Dates Between 7/1/2020 and 5/31/2021

Month	Basin PM Pipe Cleaning (miles)	High Freq PM Pipe Cleaning (miles)	Unscheduled Pipe Cleaning (miles)	CCTV Inspection (miles)	Pump Stations Preventive Maintenance Qty	Pump Stations Unscheduled Repairs Qty	SSO Cat 1	SSO Cat 2 & 3	Service Calls Call Outs
January	0.0	0.0	0.0	0.0	8	0.0	0.0	0.0	0.0
February	0.00	0.0	0.0	0.0	8	0.0	0.0	0.0	0.0
March	0.00	0.3	0.0	0.0	8	0.0	0.0	0.0	0.0
April	0.00	0.0	0.0	0.0	10	0.0	0.0	0.0	0.0
May	0.00	0.0	0.0	0.9	8	0.0	0.0	0.0	0.0
June	0.00	0.0	0.0	0.0	0	0.0	0.0	0.0	0.0
July	0.00	0.0	0.0	0.0	13	0.0	0.0	0.0	0.0
August	0.00	0.0	0.0	0.0	11	0.0	0.0	0.0	0.0
September	0.00	0.3	0.0	0.0	12	0.0	0.0	0.0	0.0
October	0.00	0.0	0.0	0.0	9	0.0	0.0	0.0	0.0
November	0.00	0.0	0.0	0.0	12	0.0	0.0	0.0	0.0
December	4.44	0.0	0.0	0.0	10	0.0	0.0	0.0	0.0
Totals	4.44	0.6	0.0	0.9	109	0.0	0.0	0.0	0.0



## WEST BAY SANITARY DISTRICT AGENDA ITEM 5F

**To:** *Board of Directors*

**From:** *Bill Kitajima, Projects & IT Manager  
Jonathan Werness, Engineering Technician*

**Subject:** *Consideration of Resolution Consenting to Annexation of Territory to the West Bay Sanitary District by the San Mateo County Local Agency Formation Commission – 4 Navajo Place, Portola Valley (077-300-130), Lands of Turnquist*

---

### Background

The owners of the property located at 4 Navajo Place, Portola Valley, Lands of Turnquist have requested the Local Agency Formation Commission (LAFCo) annex their property to the West Bay Sanitary District for the purposes of obtaining sanitary sewer service. The parcel will be a single-family residence that will need to install a Grinder pump system that will connect to a force main on Navajo Place.

### Analysis

Attached for the Board's review is the Geographic/Legal Description (Exhibit A) of the property to be annexed, the LAFCo Resolution No. 1257 (Exhibit B) approving the annexation and a site map describing the system (Exhibit C).

### Fiscal Impact

Property owners have paid all annexation fees, and the fiscal impact would be additional sewer service charge revenue to the District once the parcel is connected.

### Recommendation

The Projects Manager recommends that the District Board approve the Resolution as presented.

Attachments:      Resolution \_\_\_\_\_ (2021)  
                         Site Map  
                         Exhibit A – Geographic/Legal Description  
                         Exhibit B – LAFCo Resolution No. 1257  
                         Exhibit C – Site Map

---

**RESOLUTION NO. \_\_\_\_ (2021)**

**IN THE DISTRICT BOARD OF THE WEST BAY SANITARY DISTRICT**

**COUNTY OF SAN MATEO, STATE OF CALIFORNIA**

\*\*\*\*\*

**A Resolution Consenting to the Annexation of Lands of Turnquist (APN 077-300-130) to the West Bay Sanitary District**

**WHEREAS:**

1. A petition for annexation of the property described herein to this District was initiated by the property owners.
2. The Local Agency Formation Commission (LAFCo) of San Mateo County assigned the following distinctive short form designation: Annexation of 4 Navajo Place, Portola Valley to the West Bay Sanitary District
3. The property to be annexed is described as follows:  
See Exhibit "A" attached hereto and by this reference made a part hereof.
4. The said property is uninhabited.
5. The conditions of annexation are:
  - a. In the event that, pursuant to rules, regulations or ordinances of the District, as now or hereafter amended, the District shall require any payment of a fixed or determinable amount of money either as a lump sum or installments, for the acquisition, transfer, use or right of use of all or any part of the existing property, real or personal, of the District, such payment will be made to the District in the manner and at the time as provided by rules, regulations or ordinances of the District, as now or hereafter amended.
  - b. Upon and after the effective date of said annexation, the territory, and all persons entitled to vote by reason of residing or owning land within the territory, shall be subject to the jurisdiction of the District; shall have the same rights and duties as if the territory had been a part of the District upon its original formation; shall be liable for the payment of principal, interest and any other amounts which shall become due on account of any outstanding or then-authorized but thereafter issued bonds, including revenue bonds, or other contracts or obligations of the District; shall be subject to the levying or fixing and collection of any and all taxes, assessments, service charges, rentals or rates as may be necessary to provide for such payment; and shall be subject to all of the rates, rules, regulations and ordinances of the District, as now or hereafter amended.



6. The proposed annexation is for the interest of the landowners and present and future inhabitants within the District and within the said property to be annexed.
7. The LAFCo of San Mateo County has adopted Resolution 1257 (Exhibit "B") ordering annexation of the referenced territory to the West Bay Sanitary District.

**NOW, THEREFORE, BE IT RESOLVED** that:

- a. The above described property, pursuant to the order of the San Mateo County LAFCo, is hereby annexed to the West Bay Sanitary District, and the District Manager is directed to make such distribution of this Resolution as is required by law or is desirable.
- b. Pursuant to Government Code Section 56837, the District consents to waiver conducting authority proceedings.
- c. The regular San Mateo County Assessment Roll will be used to collect sewer service charges.
- d. The territory will not be taxed for bonded indebtedness.

\*\*\*\*\*

Passed and adopted by the District Board of the West Bay Sanitary District at a regular meeting thereof held on the 9<sup>th</sup> day of June, 2021 by the following vote:

Ayes:

Noes:

Abstain:

Absent:

---

President of the District Board of the West Bay Sanitary District of San Mateo County, State of California

Attest:

---

Secretary of the District Board of the West Bay Sanitary District of San Mateo County, State of California

ANNEXATION TO WEST BAY SANITARY DISTRICT  
GEOGRAPHIC DESCRIPTION

All that certain real property situate in the Town of Portola Valley, County of San Mateo, State of California, being all of Lot 29 in Block 1, as shown on that certain map entitled "TRACT NO. 774 ARROWHEAD MEADOWS UNIT NO. 4, BEING A PORTION OF THE RANCHO EL CORTE MADERA" filed on March 17, 1959 in Volume 50 of Maps at Pages 45-48, Records of the County of San Mateo, State of California, and being more particularly described as follows:

Beginning at the centerline intersection of Meadowood Drive and Navajo Place;

Thence (1) South 73°45'00" E 25.00 feet to the intersection of the centerline of Navajo Place and the easterly line of Meadowood Drive, Thence (2) along said easterly line of Meadowood Drive South 16°15'00" West 45.00 feet to the TRUE POINT OF BEGINNING of this description:

Thence leaving said easterly line, (3) northeasterly on the arc of a curve concave southeasterly, the center of which bears South 73°45'00" East, having a radius of 20.00 feet, a chord length of 28.28 feet, a central angle of 90°00'00" and length of 31.42 feet;

Thence (4) along the southerly line of Navajo Place (50' wide right of way) South 73°45'00" East 305.31 feet;

Thence (5) leaving said southerly line, South 24°47'01" West 150.00 feet;

Thence (6) North 71°36'25" West 303.26 feet to said easterly line of Meadowood Drive (50' wide right of way);

Thence (7) along said easterly line of Meadowood Drive North 16°15'00" East 117.00 feet to the TRUE POINT OF BEGINNING.

Containing 1.03 acres, more or less.

For assessment purposes only. This description of land is not a legal property description as defined in the Subdivision Map Act and may not be used as the basis for an offer for sale of the land described.

APPROVED  
SAN MATEO LOCAL AGENCY  
FORMATION COMMISSION  
455 COUNTY CENTER  
REDWOOD CITY, CA 94063

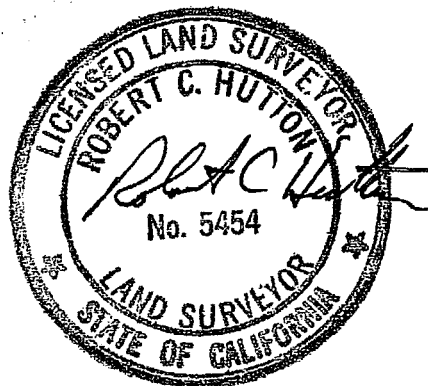
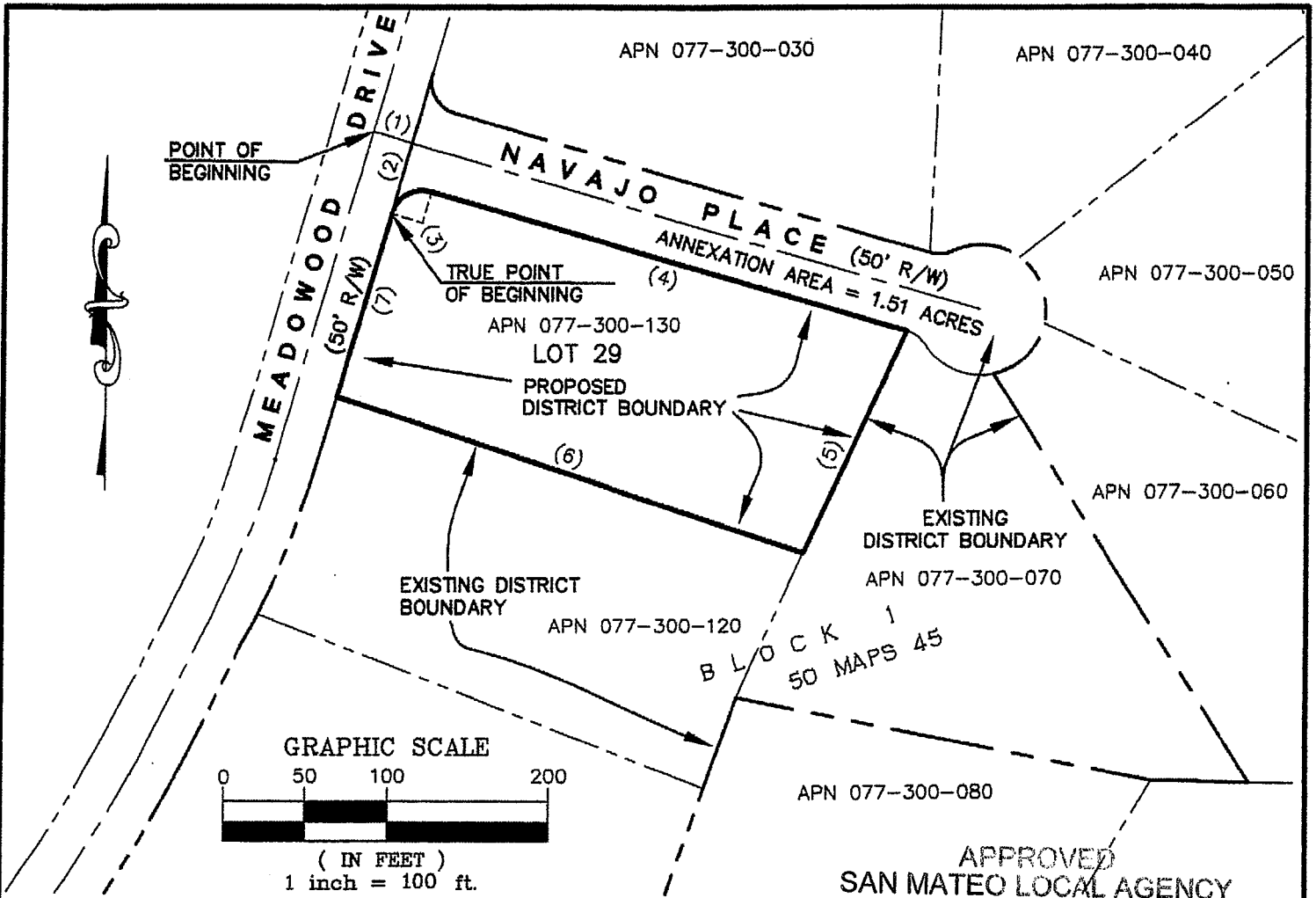

EXHIBIT A PAGE 1 OF 2



**DISCLAIMER:**

FOR ASSESSMENT PURPOSES ONLY. THIS DESCRIPTION OF LAND IS NOT A LEGAL PROPERTY DESCRIPTION AS DEFINED IN THE SUBDIVISION MAP ACT AND MAY NOT BE USED AS THE BASIS FOR AN OFFER FOR SALE OF THE LAND DESCRIBED.

APPROVED  
 SAN MATEO LOCAL AGENCY  
 FORMATION COMMISSION  
 455 COUNTY CENTER  
 REDWOOD CITY, CA 94063

EXHIBIT A PAGE 2 OF 2

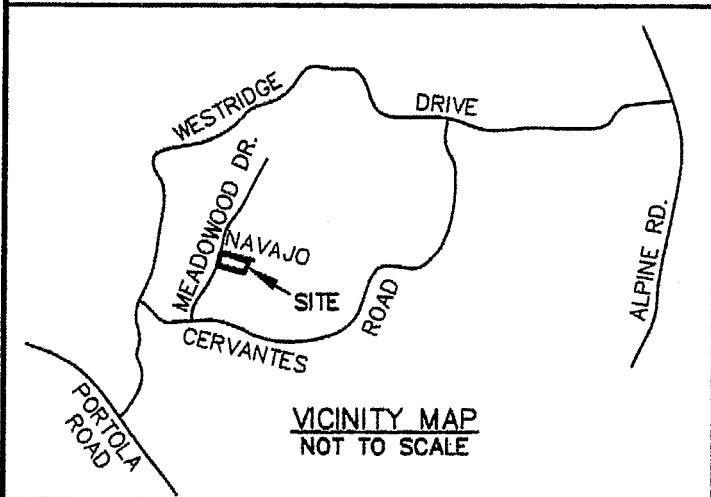

**COURSE**

1	S 73°45'00" E	25.00'	
2	S 16°15'00" W	45.00'	
3	R = 20.00' CH	= 28.28'	Δ = 90°00'00" L = 31.42'
4	S 73°45'00" E	305.31'	
5	S 24°47'01" W	150.00'	
6	N 71°36'25" W	303.26'	
7	N 16°15'00" E	117.00'	

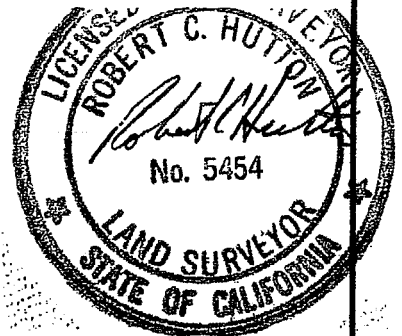

**B & H SURVEYING, INC.** 901 WALTERMIRE ST., BELMONT, CA 94002 (650) 637-1590

TITLE: ANNEXATION OF A PORTION OF THE RANCHO EL CORTE MADERA  
 TOWN: PORTOLA VALLEY COUNTY: SAN MATEO COUNTY CALIFORNIA

SURV:	SCALE: 1" = 100'	FOR:	JOB NO. 7593-20
PLAT: RCH	DATE: NOVEMBER, 2020		DWG NO. 7593-ANNEX

**2021-038942 CONF**

10:16 am 03/10/21 CCL Fee: NO FEE

Count of pages 7

Recorded in Official Records

County of San Mateo

Mark Church

Assessor-County Clerk-Recorder



**RECORDING REQUESTED BY:**

SAN MATEO LAFCO  
LOCAL AGENCY FORMATION COMMISSION

**WHEN RECORDED, PLEASE SEND TO:**

San Mateo LAFCo

**LAF 124**

(This space for Recorder's use only)

**SHORT-FORM DESIGNATION OF DOCUMENT:**

Annexation of 4 Navajo Place, Portola Valley to the West Bay Sanitary District

**RECORDER'S CODE: CCL**

(Exempt from filing fees per Government Code 6103)



**LOCAL AGENCY FORMATION COMMISSION**

455 COUNTY CENTER, 2ND FLOOR • REDWOOD CITY, CA 94063-1663 • PHONE (650) 363-4224 • FAX (650) 363-4849

**CERTIFICATE OF COMPLETION**

Pursuant to Government Code Section 57200, this Certificate is issued by the Executive Officer of the Local Agency Formation Commission of San Mateo County, California.

1. The short-form designation, as determined by LAFCo, is Annexation of 4 Navajo Place, Portola Valley to the West Bay Sanitary District.
2. The name of each district or city involved in this change of organization or reorganization and the kind or type of change of organization ordered for each city or district are as follows:

<u>City or District</u>	<u>Type of Change of Organization</u>
-------------------------	---------------------------------------

West Bay Sanitary District	Annexation
----------------------------	------------

3. The above-listed cities and/or districts are located within the following counties: San Mateo County only.
4. A description of the boundaries of the above-cited change of organization or reorganization is shown on the attached map, marked Exhibit A and by reference incorporated herein.
5. The territory involved in this change of organization or reorganization is uninhabited.
6. This change of organization has been approved subject to the following terms and conditions, if any: None.
7. The resolution confirming this change of organization was adopted on January 20, 2021 by LAFCo, is marked Exhibit B, and by reference incorporated herein.

I hereby certify that I have examined the above-cited resolution, including any terms and conditions, and the map description and have found these documents to be in compliance with Resolution 1257, adopted on January 20, 2021.

Dated: March 2, 2021

  
 Martha Poyatos  
 Executive Officer

**COMMISSIONERS:** WARREN SLOCUM, CHAIR, COUNTY ▪ MIKE O'NEILL, VICE CHAIR, CITY ▪ HARVEY RARBACK, CITY ▪ DON HORSLEY, COUNTY  
 ▪ JOSHUA COSGROVE, SPECIAL DISTRICT ▪ RIC LOHMAN, SPECIAL DISTRICT ▪ ANN DRAPER, PUBLIC

**ALTERNATES:** KATI MARTIN, SPECIAL DISTRICT ▪ DIANA REDDY, CITY ▪ JAMES O'NEILL, PUBLIC ▪ DAVE PINE, COUNTY  
 MARTHA POYATOS, EXECUTIVE OFFICER ▪ REBECCA ARCHER, LEGAL COUNSEL ▪ ROB BARTOLI, MANAGEMENT

**STAFF:** ANALYST ▪ ANGELA MONTES, CLERK

LAFCo File No. 20-09

RESOLUTION NO. 1257

**RESOLUTION OF THE LOCAL AGENCY FORMATION COMMISSION  
OF THE COUNTY OF SAN MATEO  
MAKING DETERMINATIONS, APPROVING LAFCO FILE 20-09 -  
ANNEXATION OF 25 NAVAJO PLACE, PORTOLA VALLEY  
TO THE WEST BAY SANITARY DISTRICT,  
WAIVING CONDUCTING AUTHORITY PROCEEDINGS, AND ANNEXATION  
TO THE ON-SITE WASTEWATER DISPOSAL ZONE**

APPROVED  
SAN MATEO LOCAL AGENCY  
FORMATION COMMISSION  
455 COUNTY CENTER  
REDWOOD CITY, CA 94063  
EXHIBIT B PAGE 1 OF 3

RESOLVED, by the Local Agency Formation Commission of the County of San Mateo, State of California, that

WHEREAS, a proposal for the annexation of certain territory to the West Bay Sanitary District in the County of San Mateo was heretofore filed with the Executive Officer of this Local Agency Formation Commission pursuant to Title 5, Division 3, commencing with Section 56000 of the Government Code; and

WHEREAS, the Executive Officer has reviewed the proposal and prepared a report, including the recommendations thereon, the proposal and report having been presented to and considered by this Commission; and

WHEREAS, it appears to the satisfaction of this Commission that all owners of the land included in the proposal consent to the proceeding; and

WHEREAS, a public hearing by this Commission was held on the proposal and at the hearing this Commission heard and received all oral and written protests, objections and evidence which were made, presented or filed, and all persons present were given an opportunity to hear and be heard with respect to the proposal and the Executive Officer's report; and

WHEREAS, the landowners and District have requested that the Commission waive conducting authority proceedings pursuant to government code Section 56837(c); and

WHEREAS, the proposal is categorically exempt from the environmental review requirements of

the California Environmental Quality Act (CEQA) under State CEQA Guidelines Section 15319(a) & (b) (Annexations of Existing Facilities and Lots for Exempt Facilities); and

NOW, THEREFORE, the Local Agency Formation Commission of the County of San Mateo DOES HEREBY RESOLVE, DETERMINE AND ORDER as follows:

Section 1. This proposal is approved, subject to the following conditions: None.

Section 2. The boundaries as set forth in the application are hereby approved as submitted and are as described in Exhibit "A" attached hereto and by this reference incorporated herein.

Section 3. The territory consists of 1.5 acres, is found to be uninhabited, and is assigned the following distinctive short form designation: Annexation of 4 Navajo Place, Portola Valley to the West Bay Sanitary District.

Section 4. Conducting authority proceedings are hereby waived in accordance with Government Code Section 56663 and this annexation is hereby ordered.

Section 5. Subsequent annexation to the On-Site Wastewater Disposal Zone is hereby approved.

APPROVED  
SAN MATEO LOCAL AGENCY  
FORMATION COMMISSION  
455 COUNTY CENTER  
REDWOOD CITY, CA 94063  
EXHIBIT B PAGE 2 OF 3

Regularly passed and adopted this 20th day of January 2021.

Ayes and in favor of said resolution:

Commissioners: Ann Draper  
Don Horsley  
Ric Lohman  
Kati Martin (Alternate Special District)  
Harvey Rarback  
Mike O'Neill  
Warren Slocum

Noes and against said resolution:

\_\_\_\_\_

Commissioners Absent:

APPROVED  
 SAN MATEO LOCAL AGENCY  
 FORMATION COMMISSION  
 455 COUNTY CENTER  
 REDWOOD CITY, CA 94063

EXHIBIT B PAGE 3 OF 3

Commissioners: Joshua Cosgrove



Chair  
 Local Agency Formation Commission  
 County of San Mateo  
 State of California

ATTEST:

  
 Executive Officer  
 Local Agency Formation Commission

Date: 3-2-21

I certify that this is a true and correct copy of the resolution above set forth.

Date: 3-2-21

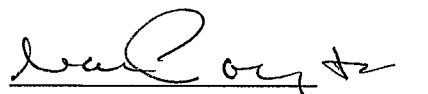
  
 Clerk to the Commission  
 Local Agency Formation Commission





WEST BAY SANITARY DISTRICT  
EXHIBIT "C"  
SITE LOCATION  
4 NAVAJO PLACE  
PORTOLA VALLEY, CA  
GRINDER SYSTEM

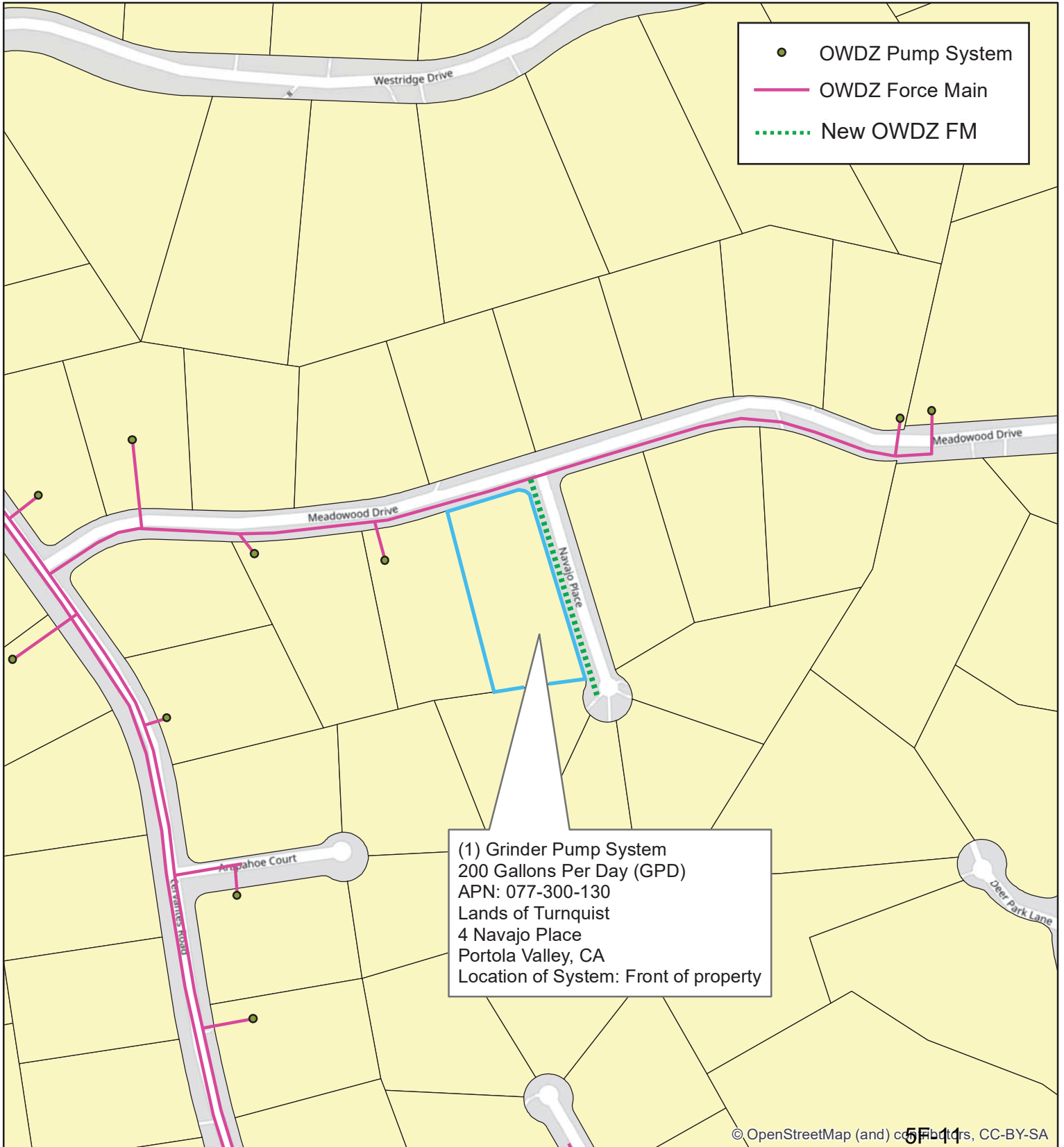

THIS PAGE LEFT INTENTIONALLY BLANK



**WEST BAY SANITARY DISTRICT  
AGENDA ITEM 5G**

**To: Board of Directors**

**From: Bill Kitajima, Projects and IT Manager  
Jonathan Werness, Engineering Technician**

**Subject: Consideration of Authorizing the District Manager to Consent to the Relocation of Public Utility Easement at 104 & 110 Constitution Drive and 115 Independence Drive, Menlo Park, properties of the Menlo Portal project.**

---

Background

The engineer for the property owner has requested that an existing Public Utility Easement (PUE) that crosses the properties be vacated, and a new PUE be deeded along a different alignment as shown in the attached exhibit.

Analysis

The District does not have any facilities within the properties.

Fiscal Impact

None

Recommendation

The Projects and IT Manager recommends the District Board authorize the District Manager to provide a "no objection" letter to the engineer.

Attachment: No objection letter  
PUE Relocation Exhibit

May 5, 2021

City of Menlo Park  
Engineering Division  
701 Laurel Street  
Menlo Park, CA 94025

**Re: Proposed Public Utility Easement Vacation at 115 Independence Drive**

To Whom it May Concern:

This letter confirms that I, on behalf of West Bay Sanitary District , have reviewed the public easement vacation proposed at 115 Independence Drive and hereby grant my approval by signing this “no objection” letter.

Thank you.

Sincerely,

\_\_\_\_\_

Date: \_\_\_\_\_



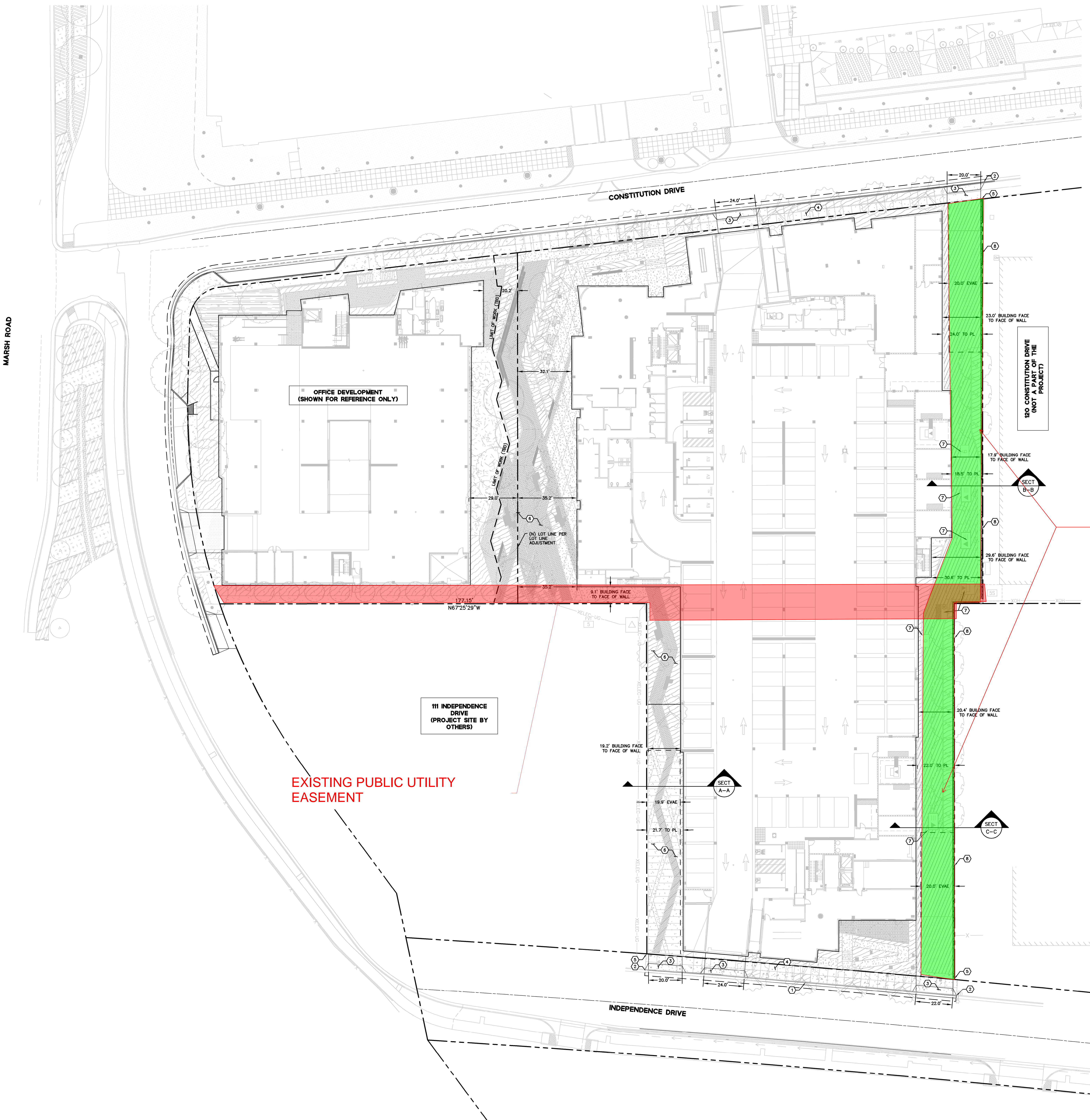
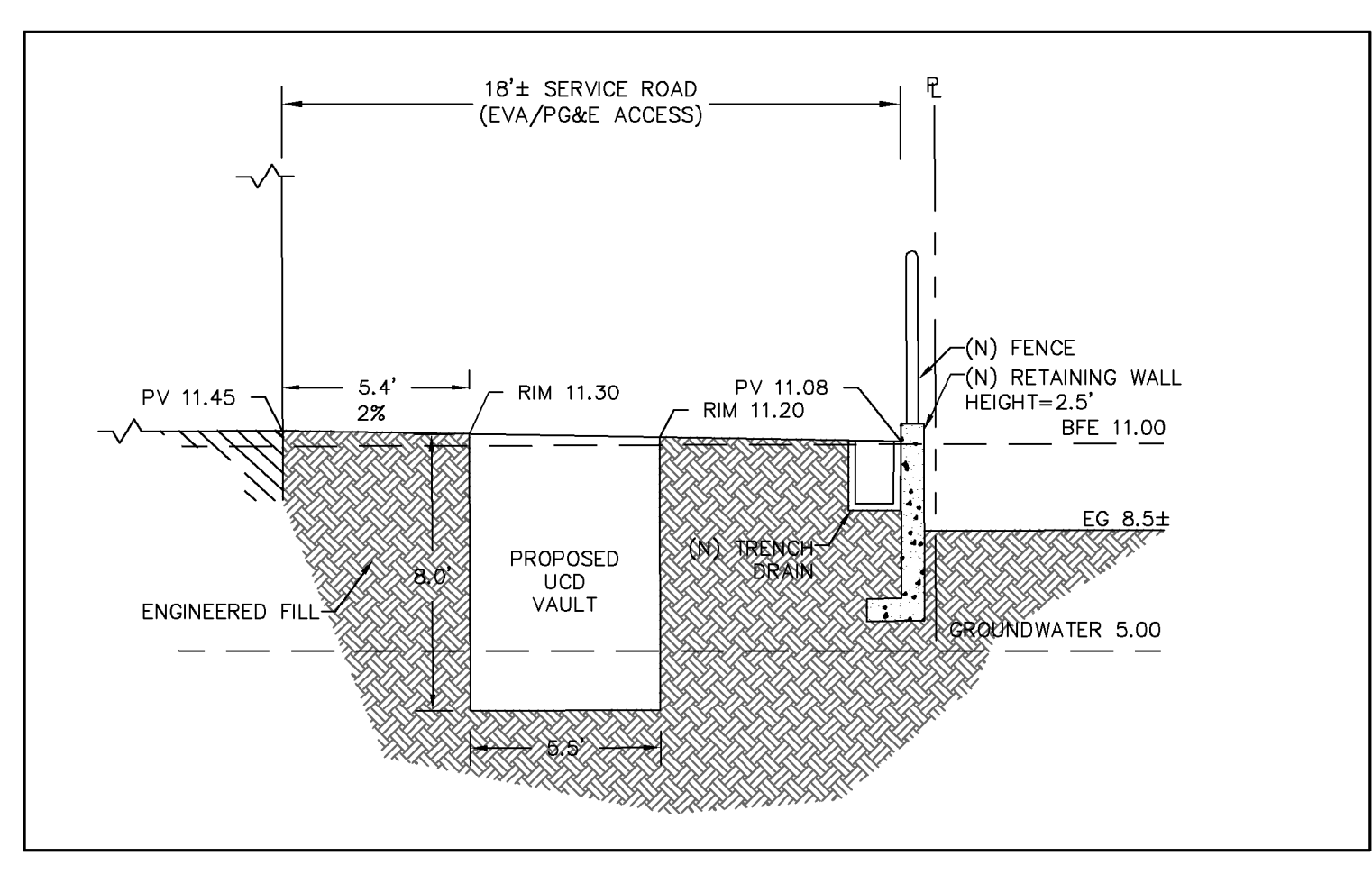
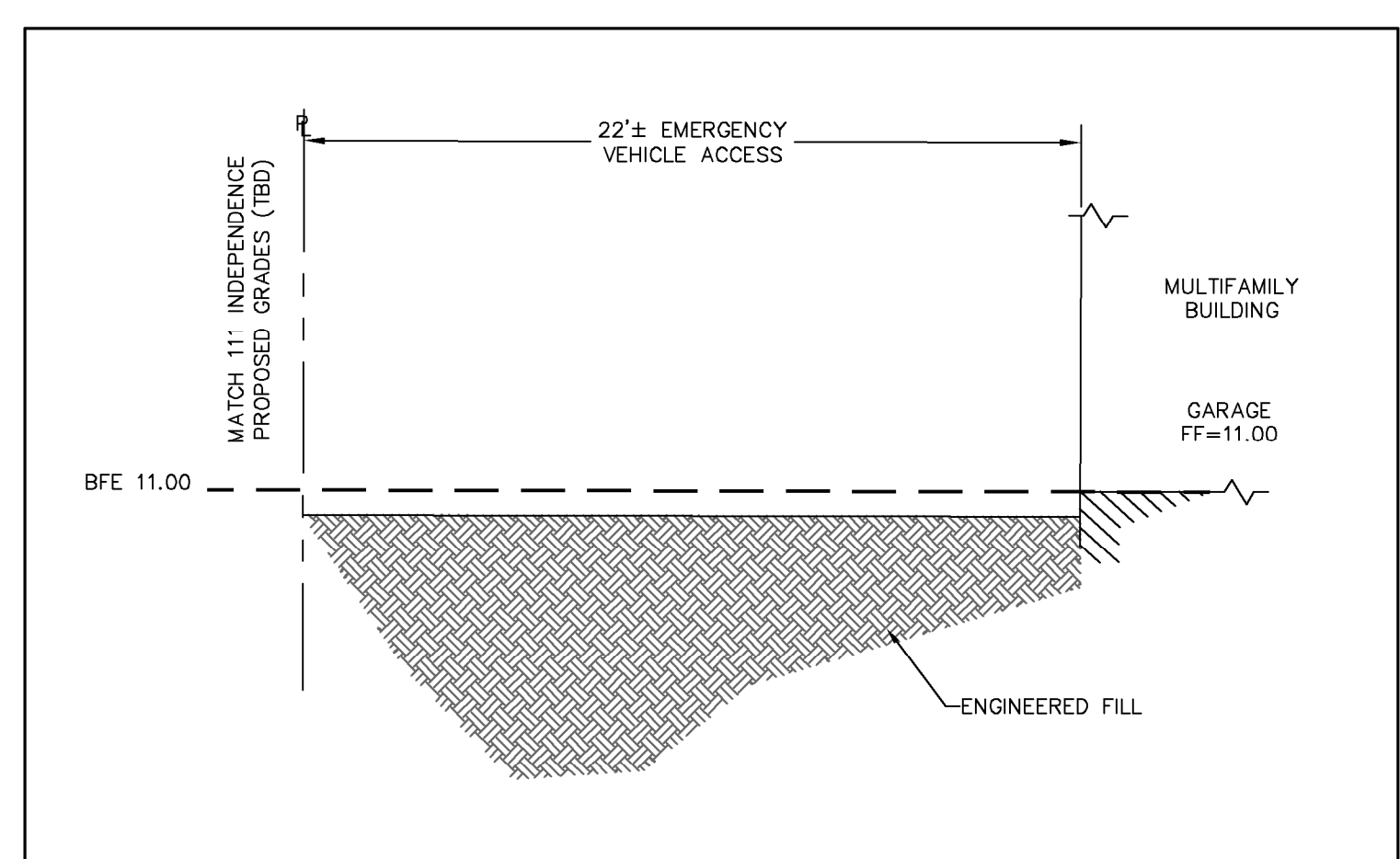

(N) PUE FOR RE-ROUTING OF FACILITIES (UNDERGROUND)

EXISTING PUBLIC UTILITY EASEMENT

**LEGEND**

	PROPERTY LINE
	EASEMENT LINE
	(N) CURB AND GUTTER PER CITY STD. DETAIL CG-3
	(N) PEDESTRIAN SIDEWALK PER CITY STD. DETAIL CG-3
	(N) PEDESTRIAN PATHWAY CONCRETE PER DETAIL 9/06.0. SEE LANDSCAPE PLANS FOR SURFACE TREATMENT
	(N) STAMPED VEHICULAR ASPHALT CONCRETE PER DETAIL 9/06.0. SEE LANDSCAPE PLANS FOR SURFACE TREATMENT
	(N) CONCRETE DRIVEWAY PER CITY STD. DETAIL CG-13
	REMOVE (E) ASPHALT CONCRETE AND REPLACE PER CITY STD. DETAIL ST-1

- KEYNOTES**
- CONSTRUCT 6" CURB AND GUTTER PER CITY DETAIL CG-2
  - CONFORM TO EXISTING CURB AND GUTTER
  - INSTALL CONCRETE DRIVEWAY PER CITY DETAIL CG-13
  - INSTALL CONCRETE SIDEWALK PER CITY DETAIL CG-1
  - CONFORM TO EXISTING SIDEWALK
  - PEDESTRIAN PATHWAY CONCRETE PER DETAIL 9/06.0. SEE LANDSCAPE PLANS FOR SURFACE TREATMENT
  - P&AE UTILITY VAULT/STRUCTURE. SEE JOINT TRENCH PLANS
  - NEW RETAINING WALL

- GENERAL NOTES**
- SEE LANDSCAPE PLANS FOR SCORING OF ON-SITE PAVERS, ENTRIES, AND WALKWAYS.
  - DIMENSIONS SHOWN FOR BUILDING LOCATIONS ARE TO FACE OF BUILDING.
  - PRIOR TO ANY COMBUSTIBLE CONSTRUCTION OR MATERIALS ON-SITE, PROVIDE FIRE ACCESS DRIVES AND OPERATIONAL ON-SITE FIRE PROTECTION SYSTEMS (FIRE HYDRANTS).
  - APPROVED FIRE APPARATUS ACCESS ROADS SHALL BE ASPHALT, CONCRETE OR ANOTHER APPROVED ALL WEATHER DRIVING SURFACE CAPABLE OF SUPPORTING THE IMPOSED LOAD OF FIRE APPARATUS WEIGHING AT LEAST 90,000 POUNDS.
  - THE BASE FLOOD ELEVATION (BFE) IS 11.00.

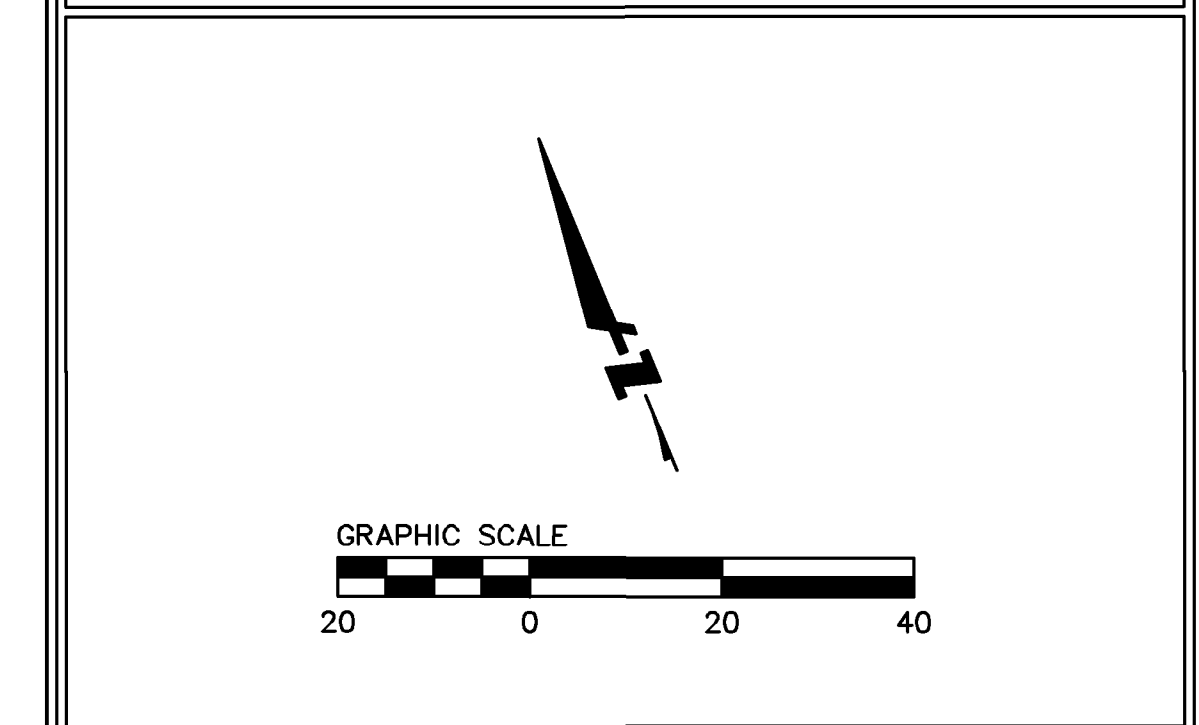

**STAMP**  
ALL DRAWINGS AND WRITTEN MATERIAL APPROVED AND CORRECTED BY SIGNING ARCHITECT AND SEAL. SEE THE WRITTEN CONSENT OF THE ARCHITECT.

**SITE PLAN**  
SHEET TITLE  
SCALE: 1"=20'  
PANEL # 181726 DRAWN BY: GCO  
SHEET SIZE: 36" x 48"



THIS PAGE LEFT INTENTIONALLY BLANK



## WEST BAY SANITARY DISTRICT AGENDA ITEM 5H

**To:** *Board of Directors*

**From:** *Debra Fisher, Finance Manager*

**Subject:** *Bank of the West Monthly Investment Portfolio Statements*

---

The District has established several reserve accounts to facilitate efficient cash flow for district operations and capital expenditures. The Recycled Water SRF Reserve was established pursuant to an agreement with Sharon Heights Golf & Country Club (SHGCC) and requirements with the California State Water Resources Control Board, as a deposit for the State Revolving Fund (SRF) loan for the Sharon Heights Recycled Water Facility, \$1.28 million cash funds have been transferred to a money market account, as requested by SHGCC management. The balance will be transfer when mature.

Target balances have been set by the Board to accomplish District goals and are evaluated annual, as part of the budget process. The Operating Reserve is set at five months of operating expenditures to fund the District during the periods between receipts of sewer service fees from the County of San Mateo from the property tax roll. Additional funds are held in Local Agency Investment Fund (LAIF), as LAIF's yields outperformed the reserve account.

<u>District Reserve Accounts</u>	<u>Target Balance</u>	<u>Target</u>
Operating Reserve	\$9.5 million	Achieved
Rate Stabilization Reserve	\$8 million	Unfulfilled
Capital Project Reserve	\$6 million	Unfulfilled
Emergency Capital Reserve	\$5 million	Unfulfilled
Recycled Water Cash Flow Reserve	\$8 million	Unfulfilled
Recycled Water SRF Reserve	\$1.46 million	Achieved
Equipment Replacement Reserve	\$0.9 million	Achieved

Attached are the monthly statement synopsis indicating the amount of each reserve fund the District holds in the Bank of the West Investment Portfolios and the up to-date market values.

Quarterly reports on the Investment Portfolios will include the details of investments of each reserve account.

### Recommendation

The Finance Manager recommends the District Board accept the Investment Portfolio Statements by affirming and approving the items listed in the Consent Calendar.



**WBSD - OPERATING RESERVE**

Account Number:  
 Statement Period:

05/01/21 -  
 05/31/21

WEST BAY SANITARY DISTRICT  
 500 LAUREL STREET  
 MENLO PARK CA 94025

**Fiduciary**  
 Chuen Ying Lee  
 (408) 645-3234  
**Portfolio**  
 Michael D. Smith  
 (408) 490-2079

**Asset Allocation**

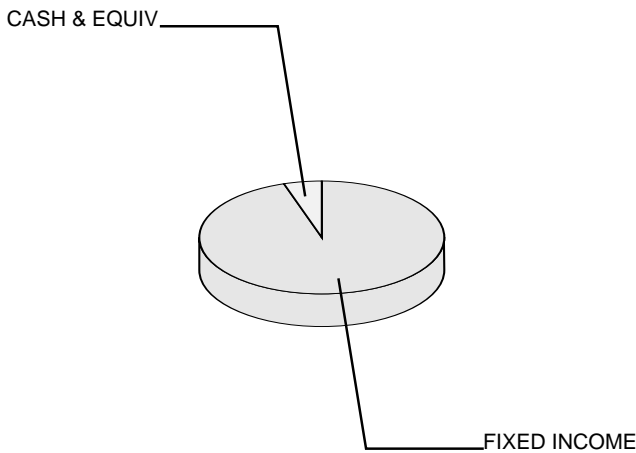

**Asset Valuation**

Description	Market Value	% of Account
Cash & Equiv	489,356.47	5.2%
Fixed Income	9,012,545.62	94.9%
<b>Total Portfolio</b>	<b>\$ 9,501,902.09</b>	<b>100.0%</b>
Accrued Income	63,369.88	
<b>Total Valuation</b>	<b>\$ 9,565,271.97</b>	

**Market Reconciliation**

	Current Period	Year To Date
<b>Beginning Market Value</b>	<b>\$ 9,555,132.32</b>	<b>\$ 9,530,903.35</b>
Income		
Interest.....	19,586.04	220,106.72
Purchased Income.....	0.00	-22,111.23
Disbursements.....	-1,574.70	-17,455.52
Realized Gains/(Losses).....	659.89	2,957.01
Change In Accrued Income.....	-1,445.33	2,473.13
Change In Market Appreciation/(Depreciation).....	-858.51	-83,457.59
Non-Cash Asset Changes.....	-6,227.74	-68,143.90
<b>Ending Market Value</b>	<b>\$ 9,565,271.97</b>	<b>\$ 9,565,271.97</b>





**WBSD - RATE STABILIZATION RESERVE**

Account Number:  
 Statement Period:

05/01/21 -  
 05/31/21

WEST BAY SANITARY DISTRICT  
 RATE STABILIZATION RESERVE  
 500 LAUREL STREET  
 MENLO PARK CA 94025

**Fiduciary**  
 Chuen Ying Lee  
 (408) 645-3234  
**Portfolio**  
 Michael D. Smith  
 (408) 490-2079

**Asset Allocation**

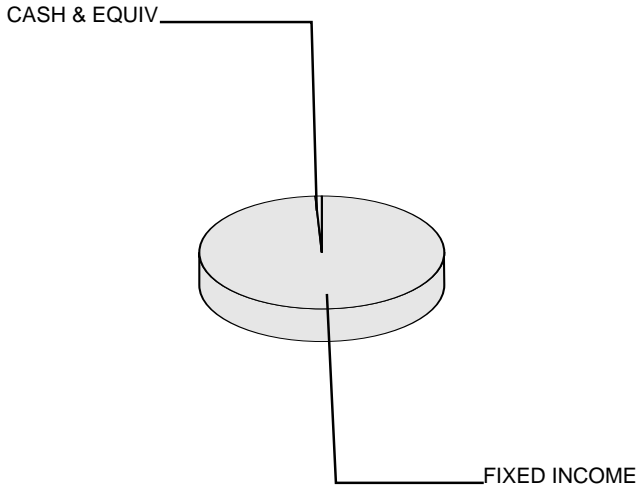

**Asset Valuation**

Description	Market Value	% of Account
Cash & Equiv	33,820.15	1.2%
Fixed Income	2,916,644.05	98.9%
<b>Total Portfolio</b>	<b>\$ 2,950,464.20</b>	<b>100.0%</b>
Accrued Income	12,901.73	
<b>Total Valuation</b>	<b>\$ 2,963,365.93</b>	

**Market Reconciliation**

	Current Period	Year To Date
<b>Beginning Market Value</b>	<b>\$ 2,959,674.71</b>	<b>\$ 1,408,407.26</b>
Income		
Interest.....	3,550.78	50,334.01
Purchased Income.....	0.00	-12,018.98
Additions.....	0.00	1,555,000.00
Disbursements.....	-489.09	-3,857.13
Realized Gains/(Losses).....	0.00	0.00
Change In Accrued Income.....	858.34	-4,551.20
Change In Market Appreciation/(Depreciation).....	1,688.61	-8,525.24
Non-Cash Asset Changes.....	-1,917.42	-21,422.79
<b>Ending Market Value</b>	<b>\$ 2,963,365.93</b>	<b>\$ 2,963,365.93</b>



**WBSD - CAPITAL PROJECT RESERVE**

Account Number:  
 Statement Period:

05/01/21 -  
 05/31/21

WEST BAY SANITARY DISTRICT  
 500 LAUREL STREET  
 MENLO PARK CA 94025

**Fiduciary**  
 Chuen Ying Lee  
 (408) 645-3234  
**Portfolio**  
 Michael D. Smith  
 (408) 490-2079

**Asset Allocation**

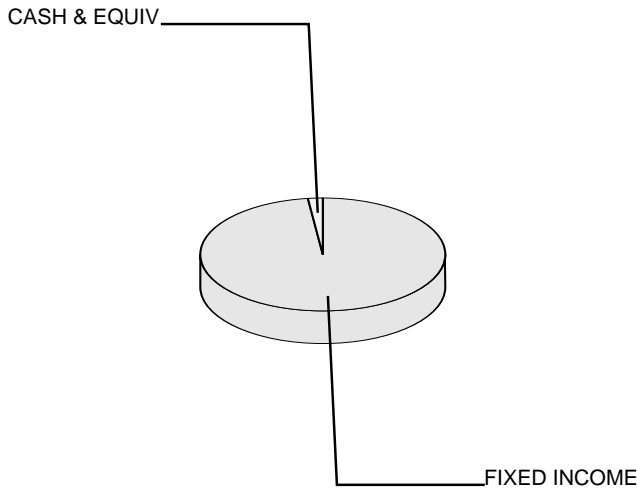

**Asset Valuation**

Description	Market Value	% of Account
Cash & Equiv	58,454.88	1.7%
Fixed Income	3,399,999.67	98.3%
<b>Total Portfolio</b>	<b>\$ 3,458,454.55</b>	<b>100.0%</b>
Accrued Income	20,436.13	
<b>Total Valuation</b>	<b>\$ 3,478,890.68</b>	

**Market Reconciliation**

	Current Period	Year To Date
<b>Beginning Market Value</b>	<b>\$ 3,473,485.43</b>	<b>\$ 2,781,874.82</b>
Income		
Interest.....	3,786.65	84,616.58
Purchased Income.....	0.00	-9,482.70
Additions.....	0.00	683,500.00
Disbursements.....	-573.43	-5,653.93
Realized Gains/(Losses).....	0.00	656.01
Change In Accrued Income.....	2,877.28	-5,097.66
Change In Market Appreciation/(Depreciation).....	-41.70	-19,195.63
Non-Cash Asset Changes.....	-643.55	-32,326.81
<b>Ending Market Value</b>	<b>\$ 3,478,890.68</b>	<b>\$ 3,478,890.68</b>



**WBSD - EMERGENCY CAPITAL RESERVE**

Account Number:  
 Statement Period:

05/01/21 -  
 05/31/21

WEST BAY SANITARY DISTRICT  
 500 LAUREL STREET  
 MENLO PARK CA 94025

**Fiduciary**  
 Chuen Ying Lee  
 (408) 645-3234  
**Portfolio**  
 Michael D. Smith  
 (408) 490-2079

**Asset Allocation**

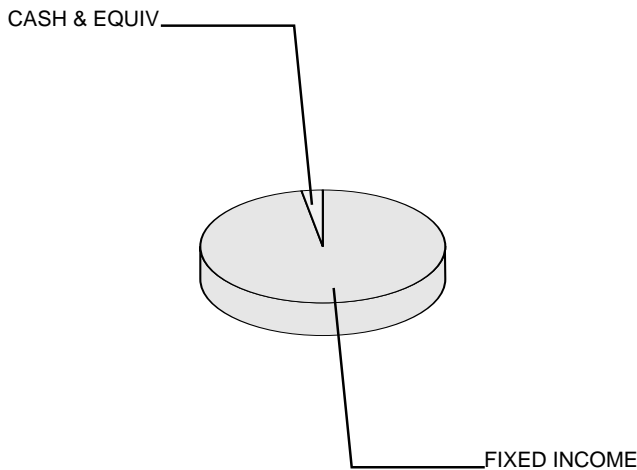

**Asset Valuation**

Description	Market Value	% of Account
Cash & Equiv	141,447.30	3.5%
Fixed Income	3,960,389.16	96.6%
<b>Total Portfolio</b>	<b>\$ 4,101,836.46</b>	<b>100.0%</b>
Accrued Income	24,057.17	
<b>Total Valuation</b>	<b>\$ 4,125,893.63</b>	

**Market Reconciliation**

	Current Period	Year To Date
<b>Beginning Market Value</b>	<b>\$ 4,120,092.25</b>	<b>\$ 3,904,702.49</b>
Income		
Interest.....	1,537.90	87,239.77
Purchased Income.....	0.00	-9,439.22
Additions.....	0.00	200,000.00
Disbursements.....	-680.59	-7,326.48
Realized Gains/(Losses).....	0.00	-1,482.50
Change In Accrued Income.....	5,708.11	-1,299.05
Change In Market Appreciation/(Depreciation).....	11.80	-19,328.19
Non-Cash Asset Changes.....	-775.84	-27,173.19
<b>Ending Market Value</b>	<b>\$ 4,125,893.63</b>	<b>\$ 4,125,893.63</b>



**WBSD - RECYCLED WATER CASH FLOW**

Account Number:  
 Statement Period:

05/01/21 -  
 05/31/21

WEST BAY SANITARY DISTRICT  
 RECYCLED WATER CASH FLOW  
 500 LAUREL STREET  
 MENLO PARK CA 94025

**Fiduciary**  
 Chuen Ying Lee  
 (408) 645-3234  
**Portfolio**  
 Michael D. Smith  
 (408) 490-2079

**Asset Allocation**

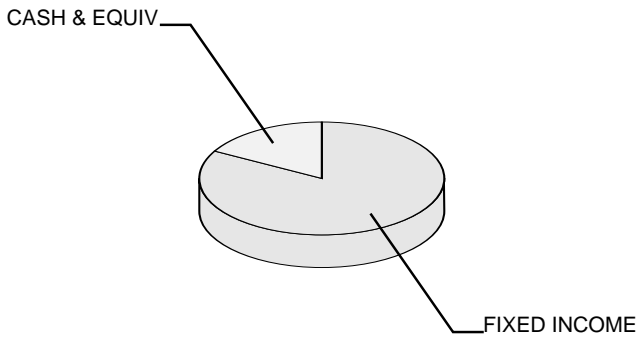

**Asset Valuation**

Description	Market Value	% of Account
Cash & Equiv	39,866.36	17.4%
Fixed Income	189,312.05	82.6%
<b>Total Portfolio</b>	<b>\$ 229,178.41</b>	<b>100.0%</b>
Accrued Income	959.56	
<b>Total Valuation</b>	<b>\$ 230,137.97</b>	

**Market Reconciliation**

	Current Period	Year To Date
<b>Beginning Market Value</b>	<b>\$ 229,765.93</b>	<b>\$ 228,463.67</b>
Income		
Interest.....	467.10	5,918.03
Purchased Income.....	0.00	-1,374.94
Disbursements.....	-37.96	-419.12
Realized Gains/(Losses).....	0.00	0.00
Change In Accrued Income.....	-48.95	-223.43
Change In Market Appreciation/(Depreciation).....	-5.15	-999.27
Non-Cash Asset Changes.....	-3.00	-1,226.97
<b>Ending Market Value</b>	<b>\$ 230,137.97</b>	<b>\$ 230,137.97</b>



**WBSD - RECYCLED WATER SRF RESERVE**

Account Number:  
 Statement Period:

05/01/21 -  
 05/31/21

WEST BAY SANITARY DISTRICT  
 RECYCLED WATER SRF RESERVE  
 500 LAUREL STREET  
 MENLO PARK CA 94025

**Fiduciary**  
 Chuen Ying Lee  
 (408) 645-3234  
**Portfolio**  
 Michael D. Smith  
 (408) 490-2079

**Asset Allocation**

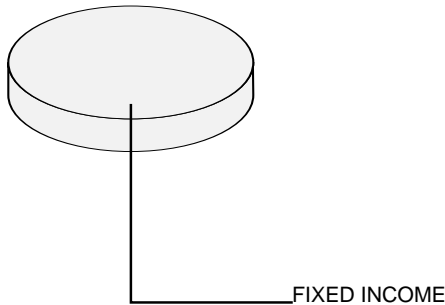

**Asset Valuation**

Description	Market Value	% of Account
Cash & Equiv	0.00	
Fixed Income	256,693.10	100.0%
<b>Total Portfolio</b>	<b>\$ 256,693.10</b>	<b>100.0%</b>
Accrued Income	1,593.92	
<b>Total Valuation</b>	<b>\$ 258,287.02</b>	

**Market Reconciliation**

	Current Period	Year To Date
<b>Beginning Market Value</b>	<b>\$ 1,539,683.36</b>	<b>\$ 1,530,349.55</b>
Income		
Interest.....	951.76	31,986.50
Purchased Income.....	0.00	-3,928.32
Disbursements.....	-1,282,146.72	-1,283,687.15
Realized Gains/(Losses).....	0.00	4,993.54
Change In Accrued Income.....	-261.98	-7,323.50
Change In Market Appreciation/(Depreciation).....	791.40	-1,720.22
Non-Cash Asset Changes.....	-730.80	-12,383.38
<b>Ending Market Value</b>	<b>\$ 258,287.02</b>	<b>\$ 258,287.02</b>

THIS PAGE LEFT INTENTIONALLY BLANK



**WEST BAY SANITARY DISTRICT  
AGENDA ITEM 6**

**To: Board of Directors**

**From: Bill Kitajima, Projects and IT Manager  
Jonathan Werness, Engineering Technician**

**Subject: Consideration of Approving Contract Change Order No. 1 to  
Aztec Consultants, Inc. for the New Metal Storage Building  
Project in Menlo Park, CA**

---

Background

The Board awarded this project at the Regular Meeting of November 14, 2018. The contractor applied for the building permit in March, 2019 and it was finally issued in April, 2021. Contract Change Order No. 1 consists of added costs that were encountered throughout the permitting process.

Analysis

The contractor was required to make several changes to the building's design in order to obtain a building permit from the City of Menlo Park, this included adding a fire protection sprinkler system, mechanical modifications, added electrical and additional material. All of this also added a significant delay to the project which incurred additional costs.

Fiscal Impact

There will be no fiscal impact to the General Fund. The Capital Assets Fund allocated a total project amount of \$745,550.00. The contractor was awarded the contract in an amount of \$745,550.00 of which an apportionment of an additional \$112,000.00 for contingency (10% for additional work and 5% for construction support services) was granted resulting in a total project amount of \$857,550.00.

Construction Costs:

Original construction bid	\$	745,550.00
Change Order No. 1	\$	385,941.00

The construction bid with Contract Change Order #1 is \$1,131,491.00.

---

Recommendation

The Projects and IT Manager recommends that the Board approve Contract Change Order No. 1 and authorizes the District Manager to execute the contract change order for \$385,941.00 to adjust the total construction bid amount to \$1,131,491.00.

Attachment                      Contract Change Order No. 1



WEST BAY SANITARY DISTRICT  
500 Laurel Street, Menlo Park, CA 94025

CHANGE ORDER  
CO NO. 1

Project: New Metal Storage Building  
Location: 1700 Marsh Road (FERRF) Menlo Park, San Mateo County, CA  
Date: June 2, 2021  
Project No. 1749.1E  
Contractor: Aztec Consultants, Inc.

Sheet 1 of 1

**The following changes are hereby made to the Contract Documents:**

1. Additional costs associated with the HVAC Design (\$29,893.00).
2. Additional costs associated with the added vents and material increases (\$60,306.00).
3. Additional costs associated with the added fire sprinkler system (\$209,364.00).
4. Additional costs associated with permits, delays and planning comments (\$86,378.00).

**Justification:**

1. Per plan review comments from the City.
2. Per plan review comments from the City.
3. Per plan review comments from the City.
4. Labor increase, final permit fees, updated drawings, additional material & special inspections.

**CHANGE TO CONTRACT PRICE:**

Original Contract Price:	\$ 745,550.00
Current Contract Price, as adjusted by previous Change Orders:	\$ 745,550.00
The Contract Price due to this Change Order will be increased by:	\$ 385,941.00
New Contract Price due to this Change Order will be:	\$1,131,491.00

**CHANGE TO CONTRACT TIME:**

The Contract Time will be increased by 2 years and 100 days.

**APPROVALS REQUIRED:**

To be effective, this order must be approved by the Owner if it changes the scope or objective of the project, or as may otherwise be required under the terms of the Contract.

RECOMMENDED AND  
APPROVED BY

\_\_\_\_\_  
Projects Manager

\_\_\_\_\_  
Date

ACCEPTED BY

\_\_\_\_\_  
Contractor

\_\_\_\_\_  
Date

AUTHORIZED BY

\_\_\_\_\_  
District Manager

\_\_\_\_\_  
Date

THIS PAGE LEFT INTENTIONALLY BLANK



## WEST BAY SANITARY DISTRICT AGENDA ITEM 7

**To:** *Board of Directors*

**From:** *Sergio Ramirez, District Manager*

**Subject:** *District Manager's Report*

---

**1) Administrative:**

- a. The California Department of Finance has concluded its audit on the District. The final exit interview was performed with staff. We are pleased to report that we received a clean audit with no official reportable items.
- b. The Board of Directors should consider a discussion regarding future development reimbursement agreements and the current annexation process. District Manager will provide a report on the matter.
- c. The proposed FY21/22 budget will be presented to the Board on June 9, 2021 Regular Board Meeting.

**2) Finance:**

- a. The Finance Manager will report on the Local Agency Investment Fund (LAIF) account at the June 9, 2021 Board Meeting.
- b. The Finance Advisory Committee met to review the Reserve Policy and District Counsel has reviewed the revised draft. The policy will come to the Board for approval on June 9, 2021.
- c. The new Money Market Account has been opened for the WBSD/SHGCC facility funds.

**3) CIP & IT Projects:**

**a. Levee Improvement Project:**

- i. Now that the Environmental Impact Review for the Levee Improvement and Bayfront Recycled Water Treatment Facility Project at the Flow Equalization and Resource Recovery Facility (FERRF) has been certified and approved, staff will continue to work on the SRF loan application. The Financial and Technical packet to the application should be approved by the Board in the June timeframe.
- ii. The Levee Project has made it through the first round of grant funding through the National Fish and Wildlife Association.

**b. Construction Capital Improvement Program (CIP)**

- i. Aztec Consultants is preparing to build the Metal Storage Building at the Flow Equalization Resource Recovery Facility.
- ii. Precision Pipeline continues to work on this year's CIP project. Staff has been working with San Mateo County to coordinate the work on Ringwood Avenue with a resurfacing project. The County has given the District two additional options in order to perform the work ahead of the county.

---

### Report to the District Board for the Regular Meeting of June 9, 2021

Additional information or topics may be introduced by the DM verbally during the Board meeting.

- iii. Freyer & Laureta is working on the Bay Front Improvement projects including the Influent Pump Station.
- 4) **Operations and Maintenance:**
  - a. **Collection System:**
    - i. Crews have been working on the Town of Los Altos Hills collection system.
  - b. **Training:**
    - i. Safety training has been ongoing with the assistance of a DuALL Safety consultant.
- 5) **Water Quality:**
  - a. **Sharon Heights Golf and Country Club (SHGCC):**
    - i. The recycled water plant has been operating well. Staff is regularly working with SHGCC staff to better predict their water requirements.
  - b. **Bayfront Recycled Water Facility (BRWF):**
    - i. After approving the EIR, the next step will be to enter into developer agreements with developers in the Bayfront Area. District Counsel has prepared the Draft Recycled Water Code to be shared with the City of Menlo Park.
  - c. **West Bay:**
    - i. Source Control Staff has been performing FOG inspections.
- 6) **Fleet and Facilities:**
  - a. **Vehicle Maintenance:**
    - i. After reviewing the option to lease a hybrid vehicle it makes sense to do so and will be proposed in the Budget.
- 7) **Personnel:**
  - i. District Manager is reorganizing a portion of the Admin Staff.
- 8) **Upcoming Events:**
  - a. **Regular Board Meeting:** June 9, 2021
  - b. **Next Regular Board meetings:** June 23, 2021
- 9) **Misc./Action Items from Previous Meeting:**
  - a. **West Bay SSOs:** Zero SSOs for May 2021.
  - b. **LAH Contract:** LAH did not have SSOs in May.
  - c. **Town of Woodside Contract:** Staff received the amended agreement for FY21/22.
  - d. **Revenue:** The final Sewer Service Charge for FY20/21 has been received from the County in the amount of \$2.7M. These rate payers are billed manually. To-date the District is owed approximately \$14,000.

---

## Report to the District Board for the Regular Meeting of June 9, 2021

Additional information or topics may be introduced by the DM verbally during the Board meeting.



**WEST BAY SANITARY DISTRICT  
AGENDA ITEM 8**

**To:** *Board of Directors*

**From:** *Debra Fisher, Finance Manager*

**Subject:** *Discussion on Local Agency Investment Fund (LAIF)  
Allocations*

**Background**

The District joined the Local Agency Investment Fund (LAIF) in 1985, a program created by statute in 1977 as an investment alternative for California's local governments and special districts, managed by the California State Treasurer's Office as part of the Pooled Money Investment Account (PMIA) of the state of California. LAIF has 2,379 participants and over \$35.5 billion in assets, as of April 30, 2021. Funds in LAIF are considered a cash equivalent, as the District has an account which earns interest and our principal is not subject to loss.

The District holds funds in LAIF in one account. Although the account is not restricted for any one purpose, the funds can be identified as reserved for specific funds and liabilities. Below is a list of the major liabilities whose funds would be transferred from LAIF, if unavailable in the General Account.

The Unreserved Balance is the net funds, less those specifically reserved and the Reserve Target Deficits. The negative \$1.69 million is the balance if all targets were funded, indicating that the District does not have sufficient funds to meet all reserve targets, based on the FY 2021-22 budget. The total unreserved is \$7.8 million (Unreserved Balance plus Reserve Target Deficits).

<u>Local Agency Investment Fund (LAIF)</u>	<u>Actual 6/30/20</u>	<u>Actual 3/31/21</u>	<u>Estimate 6/30/21</u>	<u>Estimate 6/30/22</u>
Reserved:				
Operating Reserve			9,385,292	10,758,057
Recycled Water Cash Flow Reserve	7,313,135	7,344,859	7,344,859	7,344,859
Capital Budget, less Capital Reserves	6,753,129	9,284,401	6,709,676	-
Solid Waste Fund	243,405	244,484	183,366	183,366
Deposits	4,038,990	2,761,819	2,523,362	2,284,906
Unreserved Balance	5,976,944	7,133,052	193,463	(1,690,420)
Reserve Target Deficits	11,739,698	9,031,684	12,000,000	9,500,000
<b>LAIF Balance</b>	<b>36,065,300</b>	<b>35,800,299</b>	<b>38,340,019</b>	<b>17,622,711</b>

**Fiscal Impact**

No fiscal impact.

**Recommendation**

For the Board review and information only.



## WEST BAY SANITARY DISTRICT AGENDA ITEM 9

**To:** *Board of Directors*

**From:** *Sergio Ramirez, District Manager*  
*Debra Fisher, Finance Manager*

**Subject:** *Consideration to Approve the District Reserve Policy*

---

### **Background**

On October 13, 2010, the Board designated Bank of the West as the District's Investment Advisor and authorized the District Manager to transfer to and from Bank of the West Investment Management & Trust funds designated by the District Board as long-term investment funds. The reserves are managed by Bank of the West on behalf of the District.

Reserves were established to facilitate efficient district operations, capital expenditures, or as required by regulations or agreement and provide for known future funding needs and emergencies.

The Finance Committee met on June 2, 2021 to reviewed the Reserve Policy and discuss proposed changes. The following policy revisions are recommended.

- Increase Operating Reserve from five to six months of operations and keep in LAIF, which is more liquid, to provide cash flow needs from July to December, when the first sewer service charges are received.
- Transfer funds from Operating Reserve Investment account to fully fund other reserve Target balances.
- Establish Treatment Plant Reserve (TRP), by converting Operating Reserve Investment account balance and begin to fund the TPR to a target level of \$12 million.
- Increase Rate Stabilization Reserve to \$10 million, from \$8 million.
- Clarify language on reserves, procedures for using reserves, and update procedures for monitoring reserves levels.

### **Fiscal Impact**

Reserves would better align with cash flow needs of the District. Preparing for future large cash flow needs allows the District to manage funds efficiently, save interest by avoiding future debt, and manage rate increases more smoothly. Operating Reserves

---

would be held in the more liquid LAIF account, allowing efficient transfer of funds for operating needs between July and December, when the first sewer service fees are received and to avoid possible liquidation costs from investment accounts.

The following is a list of all reserve accounts, the balances as of May 31, 2021, the targets in the Reserve Policy, and the deficit (negative) or excess (positive) amounts, based on the target balance. The reserves are \$10,791,581 under the target balances.

<u>Reserve Balances 5/31/2021</u>	<u>Target</u>	<u>Investments</u>	<u>Funds in LAIF/MN</u>	<u>Total Reserves</u>	<u>Deficit/Excess</u>
<b><u>General Fund</u></b>					
Operating Reserve	9,500,000	9,565,272		9,565,272	65,272
Rate Stabilization Reserve	10,000,000	2,963,366		2,963,366	(7,036,634)
Public Agency Retirement Services (PARS):				-	
Other Post-Employment Benefits (OPEB)		320,810		320,810	
Pension		233,543		233,543	
<b><u>Capital Fund</u></b>					
Capital Project Reserve	6,000,000	3,478,891		3,478,891	(2,521,109)
Emergency Capital Reserve	5,000,000	4,125,894		4,125,894	(874,106)
Equipment Replacement Money Market			969,357	969,357	
Recycled Water Cash Flow Reserve	8,000,000	230,138	7,344,859	7,574,997	(425,003)
<b><u>Recycled Water Fund</u></b>					
Restricted - Recycled Water SRF Reserve	1,458,404	258,287	1,282,197	1,540,484	82,080

\* PARS balance as of 4/30/21 (latest available)

**Recommendation**

The District Manager recommends the Board approve the Reserve Policy and authorize the District Manager to transfer funds as described, and directed by the Finance Committee.





# West Bay Sanitary District

## Reserve Policy

(Approved ~~October~~ June 9, 2021)

### PURPOSE

West Bay Sanitary District (~~the~~ District) shall maintain reserves in the General and Capital Asset Funds ~~to~~ to. ~~This policy establishes~~ ss the levels of reserves necessary for maintaining the District's credit worthiness and ~~for~~ adequately providing for:

- Funding infrastructure replacement.
- Economic uncertainties and other financial hardships.
- Loss of significant revenue sources such as property tax receipts or connection fees.
- Local disasters ~~or~~ catastrophic events.
- Future debt or capital obligations.
- Cash flow requirements
- Unfunded mandates including costly regulatory requirements.

### POLICY

#### Operating Reserves (General Fund)

The ~~minimum~~ amount of operating reserves will equal ~~five~~ six months of operating expenses. ~~At the start of a new fiscal year, funds are added earmarked to specifically for the operating expenses Reserve and are to equal five to six months of budgeted total expenses (excluding depreciation) for that year, when available.~~ The ~~key~~ objective for this reserve is to provide ~~for~~ adequate cash flow ~~from in the period of the year, July through December 15,~~ when the District ~~does not~~ receives ~~no~~ revenue ~~in the form from of~~ sewer service charges.

The Rate Stabilization Reserve (RSR) was established in FY2015-16 to build a reserve to stabilize future rate increases. As approved by the Board through the budget approval process, contributions are made to the reserve. The target for the RSR is established as \$10&M.

The Treatment Plant Reserve (TPR) has been established to assist in stabilizing rates due to future treatment plant needs. The target level for this reserve is \$12M.

#### Public Agency Retirement Services (PARS) Trust/PERS Liability Reserves

The District ~~has~~ established a Public Agency Retirement Services (PARS) Trust, with separate Public Employee Retirement System (PERS) and a Other -Post-Employment Benefits (OPEB) and Pension funds. The funds are, trust program administered by ~~PARS (Public Agency Retirement Services)~~ for the purpose of pre-funding pension and retirement benefit liabilities. ~~These is~~ reserves are is an irrevocable trusts as defined by the Internal Revenue Service (IRS), and PARS uses mutual fund earnings to accumulate interest and gains that which can be used for payment of pension liabilities for PERS retirement and OPEB costs and PERS accumulated Unfunded Accrued Pension Liabilities.

~~The Rate Stabilization Reserve (RSR) was established in FY2015-16 to build a reserve to stabilize future rate increases. As approved by the Board through the budget approval process, contributions are made to the reserve, as well as, unspent balances remaining in the Non-Operating Expenses budget at year end. The target for the RSR is \$8M.~~

#### Capital Reserves—(Capital Asset Fund)

The Capital Projects Reserves (CPR) will be accumulated to fund infrastructure projects and will be an integral part of the District's capital improvement plan documented in its Ten-Year Capital Improvement Master Plan. A key objective for accumulating capital reserves is to minimize potential external borrowing and interest expenses. The target for the Capital Projects Reserve, for emergency cash flow funding of Capital Projects, is fully funded at the target level of \$3.5M to \$6 Mmillion.

The Emergency Capital Reserve (ECR) was established to cover cash flow requirements in the event of catastrophic or local disasters. It is considered fully funded at a target level of \$5M.

The Equipment Replacement Reserve (ERR) was established to stabilize expenditures for purchases of large equipment and vehicles. This reserve was initially funded with \$215,000 in FY2015-16 and with other contributions has grown to approximately \$600,000. Contributions are added annually through the budget process based on year over year by 3%. CPI increases. The ERR can fluctuate depending on equipment needs.

~~The Rate Stabilization Reserve (RSR) was established in FY2015-16 to build a reserve to stabilize future rate increases. It was initially funded with \$3M. As approved by the Board through the budget approval process, contributions of \$1M are made to the reserve, as well as, unspent balances remaining in the Non-Operating Expenses budget at year end, are added to the reserve annually. The target for the RSR is \$8M to 10M.~~

The Recycled Water Facility Cash Flow Reserve (RWFR) was established with \$8M with the specific objective to fund expenditure requirements of ~~the~~ Recycled Water Projects, such as, Sharon Heights and Bayfront. The reserve is used while awaiting reimbursement from ~~the project partners or the~~ California State Revolving Fund (SRF) or project partners. No further additions to this fund are anticipated. Upon completion of the projects ~~the reserves would could~~ be reallocated per Board direction to the eGeneral fFund.

#### Recycled Water Fund

Restricted reserves may be setup and maintained to support agreements with District partners. The Sharon Heights Recycled Water Facility Reserve is a restricted reserve to hold funds of Sharon Heights Golf and Country Club as required by their long-term agreement as a security deposit for the SRF loan. The balance is dictated by the terms of their agreement.

## **PROCEDURE FOR USING RESERVE FUNDS**

### Operating Reserves

Operating ~~R~~eserves can be used to meet cash flow requirements of District operations. Authority to use the funds will be consistent with the District's ~~fiscal policies, including the annual Approved Budget, Finance Policy,~~ and Purchasing Policy.

### Capital Reserves

The Board of Directors will authorize use of ~~C~~apital ~~R~~eserves during the budget process. ~~Capital Reserves are also available for unplanned (unbudgeted) capital replacement.~~ Authorization for the use of ~~e~~Capital ~~R~~eserves for unplanned capital replacement will be consistent with the District's ~~Financing Policy~~~~fiscal policies, including the~~ ~~and~~ Purchasing Policy. ~~Capital Reserve are~~ ~~and~~ subject to Board approval prior to their use.

### PARS Trust/PERS Liability Reserves (Other Post-Employment Benefit Trust)

The Board of Directors ~~may~~will authorize the use of interest and/or principal from the PARS Trust towards the District's OPEB and PERS Unfunded Accrued Liability (UAL) or current accumulated Unfunded pPension ~~!~~Liabilities. This fund is an irrevocable trust and is strictly for the use of paying the District's Other Post-Employment Benefits and pension liabilities. This fund has no requirement to be used in any fiscal year and can be allowed to accumulate to the level desired by the Board to be used at a future date. ~~The fund can be used for OPEB, UAL, and PERS obligations and contributions. The fund may~~could be used to assist to offset Employer Contributions and help stabilize annual pension fluctuations~~fluxuations~~budget increases.

### **PROCEDURE FOR MONITORING RESERVE LEVELS – Monthly**

A reserve analysis is submitted to the Board upon the occurrence of the following events:

- Monthly Financial Analysis Reports are provided to the board showing all receipts, distributions, and transfers for the previous month.
- Monthly summary Investment Portfolio Statements, for all investment accounts, are provided to the board for the previous month.
- ~~Monthly~~Quarterly reports~~analysis~~ of reserve balances and performance are submitted to the Board of Directors for their review and approval.
- Board of Directors' reviews target levels of reserves during~~deliberation of the annual budget. Reserves~~ ~~are~~should be reviewed ~~annually~~ to determine if levels are still adequate and keeping up with inflation.
- Board of Director' deliberation of a sewer service charge rate increase.
- ~~When a~~A major change in conditions threatens the reserve levels established within this policy.

If the analysis indicates projected or actual reserve levels falling 10% below or above the levels outlined in this policy, at least one of the following actions shall be included with the analysis:

- An explanation of why the reserve levels are not at the targeted level, ~~and/or~~
- An identified course of action to bring reserve levels within the minimum and maximum levels prescribed.



## West Bay Sanitary District

### Reserve Policy

(Approved June 9, 2021)

#### PURPOSE

West Bay Sanitary District (District) shall maintain reserves in the General and Capital Asset Funds to establish levels of reserves necessary for maintaining the District's credit worthiness and adequately providing for:

- Funding infrastructure replacement.
- Economic uncertainties and other financial hardships.
- Loss of significant revenue sources such as property tax receipts or connection fees.
- Local disasters, catastrophic events.
- Future debt or capital obligations.
- Cash flow requirements
- Unfunded mandates including costly regulatory requirements.

#### POLICY

##### Operating Reserves (General Fund)

The amount of operating reserves will equal six months of operating expenses. Funds are earmarked specifically for the operating expenses and are equal to six months of budgeted total expenses (excluding depreciation) for that year. The key objective for this reserve is to provide adequate cash flow from July through December, when the District does not receive revenue from sewer service charges.

The Rate Stabilization Reserve (RSR) was established in FY2015-16 to build a reserve to stabilize future rate increases. As approved by the Board through the budget approval process, contributions are made to the reserve. The target for the RSR is established at \$10M.

The Treatment Plant Reserve (TPR) has been established to assist in stabilizing rates due to future treatment plant needs. The target level for this reserve is \$12M.

The District established a Public Agency Retirement Services (PARS) Trust, with separate Other Post-Employment Benefits (OPEB) and Pension funds. The funds are administered by PARS for the purpose of pre-funding pension and retirement benefit liabilities. These reserves are irrevocable trusts as defined by the Internal Revenue Service (IRS). PARS uses mutual fund earnings to accumulate interest and gains which can be used for payment of liabilities for PERS retirement and OPEB costs.

### Capital Asset Fund

The Capital Projects Reserves (CPR) will be accumulated to fund infrastructure projects and will be an integral part of the District's capital improvement plan documented in its Ten-Year Capital Improvement Master Plan. A key objective for accumulating capital reserves is to minimize potential external borrowing and interest expenses. The target for the CPR is \$6 million.

The Emergency Capital Reserve (ECR) was established to cover cash flow requirements in the event of catastrophic or local disasters. It is considered fully funded at a target level of \$5M.

The Equipment Replacement Reserve (ERR) was established to stabilize expenditures for purchases of large equipment and vehicles. This reserve was initially funded with \$215,000 in FY2015-16. Contributions are added annually through the budget process by 3%. The ERR can fluctuate depending on equipment needs.

The Recycled Water Facility Reserve (RWFR) was established with \$8M with the specific objective to fund expenditure requirements of Recycled Water Projects, such as, Sharon Heights and Bayfront. The reserve is used while awaiting reimbursement from the California State Revolving Fund (SRF) or project partners. No further additions to this fund are anticipated. Upon completion of the projects the reserves could be reallocated per Board direction to the General Fund.

### Recycled Water Fund

Restricted reserves may be setup and maintained to support agreements with District partners. The Sharon Heights Recycled Water Facility Reserve is a restricted reserve to hold funds of Sharon Heights Golf and Country Club as required by their long-term agreement as a security deposit for the SRF loan. The balance is dictated by the terms of their agreement.

## **PROCEDURE FOR USING RESERVE FUNDS**

### Operating Reserves

Operating Reserves can be used to meet cash flow requirements of District operations. Authority to use the funds will be consistent with the District's fiscal policies, annual Approved Budget, and Purchasing Policy.

### Capital Reserves

The Board of Directors will authorize use of Capital Reserves during the budget process. Authorization for the use of Capital Reserves for unplanned capital replacement will be consistent with the District's fiscal policies, including the Purchasing Policy. Capital Reserve are subject to Board approval prior to their use.

## PARS Trust

The Board of Directors may authorize the use of interest and/or principal from the PARS Trust towards the District's OPEB and PERS Unfunded Accrued Liability (UAL) or current pension liabilities. This fund is an irrevocable trust and is strictly for the use of paying the District's Other Post-Employment Benefits and pension liabilities. This fund has no requirement to be used in any fiscal year and can accumulate to the level desired by the Board to be used at a future date. The fund may be used to offset employer contributions and help stabilize annual pension fluctuations.

### **PROCEDURE FOR MONITORING RESERVE LEVELS**

A reserve analysis is submitted to the Board upon the occurrence of the following events:

- Monthly Financial Analysis Reports are provided to the Board showing all receipts, distributions, and transfers for the previous month.
- Monthly summary Investment Portfolio Statements, for all investment accounts, are provided to the Board for the previous month.
- Quarterly reports of reserve balances and performance are submitted to the Board of Directors for their review and approval.
- Board of Directors reviews target levels of reserves during deliberation of the annual budget. Reserves are reviewed to determine if levels are still adequate and to keeping up with inflation.
- Board of Director deliberation of a sewer service charge rate increase.
- A major change in conditions threatens the reserve levels established within this policy.

If the analysis indicates projected or actual reserve levels falling 10% below or above the levels outlined in this policy, at least one of the following actions shall be included with the analysis:

- An explanation of why the reserve levels are not at the targeted level.
- An identified course of action to bring reserve levels within the minimum and maximum levels prescribed.

THIS PAGE LEFT INTENTIONALLY BLANK





**WEST BAY SANITARY DISTRICT  
AGENDA ITEM 10**

**To: Board of Directors**

**From: Debra Fisher, Finance Manager**

**Subject: Consideration to Approve Budget Revision for FY 2020-21 to Reallocate Reserve Contribution from Operating Reserve to the Rate Stabilization Reserve**

**Background**

On June 10, 2020 the District’s Fiscal Year 2020-21 budget was approved by the Board of Directors. The approved budget called for \$4,099,000 in contributions to reserves. Year to date, \$2,799,000 has been contributed to reserve accounts in FY 2020-21, as prescribed by the budget. The \$1.3 million transfer to the Operating Reserve was not transferred, since that account was at the target level.

**Approved Budget FY 2020-21:**

	Budget FY 2019-20	Actual 6/30/2020	Budget FY 2020/21	Budget Variance	% Var
<b>CONTRIBUTIONS TO RESERVES</b>					
Operating Reserves Transfers (Target Goal \$9M)	0	1,300,000	1,300,000	1,300,000	
Rate Stabilization/Bond Reserve (Target Goal \$8M)	1,000,000	0	1,555,000	555,000	56%
Capital Project Reserves Transfers (Target Goal \$6M)	350,000	683,500	683,500	333,500	95%
Emergency Capital Reserves Transfer (Target Goal \$5M)	0	200,000	200,000	200,000	
Contributions To Vehicle & Equip Replacement Reserve	350,000	270,000	360,500	10,500	3%
Recycled Water Facility Cash Flow Reserve	0	0	0		
Recycled Water SRF Reserve	0	0	0		
<b>TOTAL CONTRIBUTIONS TO RESERVES</b>	<b>1,700,000</b>	<b>2,453,500</b>	<b>4,099,000</b>	<b>2,399,000</b>	<b>141%</b>

The Finance Committee met on June 2, 2021 and recommended contributing the \$1.3 million to the Rate Stabilization Reserve, which is currently more than \$3.7 million under the \$8 million target balance.

**Fiscal Impact**

No fiscal impact. Reserves contributions were approved in the FY 2020-21 budget. Funds would be transferred to Rate Stabilization Reserve instead of Operating Reserve.

**Recommendation**

The Finance Manager recommends the Board reallocate the contribution of \$1.3 million, budgeted as contribution to Operating Reserves, to Rate Stabilization Reserve and authorize the District Manager to reallocate reserves per the Reserve Policy.



## WEST BAY SANITARY DISTRICT AGENDA ITEM 11

**To:** *Board of Directors*

**From:** *Debra Fisher, Finance Manager*  
*Sergio Ramirez, District Manager*

**Subject:** *Consideration to Approve Resolution Adopting FY 2021-22 Budget*

---

### **Background**

Attached for the Board's review is the Proposed Budget for fiscal year (FY) 2021-22. Each fund is reported separated to better view the primary operations and other activities in the; General, Capital, Solid Waste, and Recycled Water Funds.

### **Fiscal Impact**

#### **General Fund:**

Operating Revenue is \$30,872,989, a 2.2% decrease from FY 2020-21 annual budget. Operating Expense is \$24,704,200, 2.8% decrease from FY 2020-21 annual budget. This includes contributions to Silicon Valley Clean Water (SVCW) of \$12,396,490, 57.6% of the total Operating budget. SVCW expenses are decreasing 5.8% due to lower flows at the Menlo Park Pump Station and refinancing of debt at lower interest rates. The District's Net Operating Income is \$6,168,697.

Non-Operating Revenues are increased to \$351,000 from \$51,000, to better reflect expected interest income on long-term reserves. Non-Operating Expenses are unchanged at \$6,000.

The General Fund budget includes a \$6,513,697 increase in Change in Net Position, which is available for capital expenditures; 5% over FY 2020-21.

#### **Capital Fund:**

The Capital Fund estimates revenue from Connection Fees of \$250,000, unchanged from FY 2020-21 annual budget. In FY 2020-21, \$219 thousand has been received through 3/31/21.

---

Capital Expenditures of \$12,811,750 are budgeted for FY 2021-22 in capital purchases and construction for District Operations, which are capitalized as projects are completed.

**Solid Waste Fund:**

The Solid Waste Fund estimates \$100,000 in Franchise Fees from Recology, which manages solid waste collection for the District, accounting for increased expenses due to additional service routes.

Solid Waste Expenditures of \$105,090 are budgeted for rate studies, annual notification mailing, and overhead allocation.

The Solid Waste Fund budget decreases the Net Position by \$5,090, to a \$247,494 ending fund balance.

**Recycled Water Fund:**

The Recycled Water Fund includes the Sharon Heights Recycled Water Facility and the Bayfront Project.

Sharon Heights Recycled Water Facility (SHRWF) was accepted July 27, 2020 and has a Clean Water State Revolving Fund (SRF) loan balance of \$16,616,382, as of March 31, 2021.

The SHRWF budget estimates Operating Revenue of \$503,224 on Expenditures of \$503,224, excluding \$754,902 in depreciation of the facility. The SHRWF passes through costs to Sharon Heights Golf & Country Club (SHGCC), including \$15,557 in overhead which offsets costs in the General Fund.

The Bayfront Project is in the planning stages, with no direct Revenue or Expenditures. \$1 million in Capital Expenditures is budgeted for FY 2021-22, for total projected Construction In Progress (CIP) expenditures of \$1,577,625.

**Financial Statements Summary:**

The following is a summary of the FY 2021-22 Budget, for the General Fund and the Change in Net Position for other Funds, compared with the actual for the quarter ending March 31, 2021, which varies slightly with the Third Quarter Report, as other accrued income and expenses were identified after reporting.

	Budget FY 2020/21	YTD 3/31/2021	Projected 6/30/21	Budget FY 2021/22	Budget Variance	% Var
Operating Revenues	31,579,058	24,292,481	32,179,160	30,872,898	(706,161)	-2.2%
Operating Expenses	(12,271,022)	(10,580,479)	(18,941,800)	(12,307,711)	(36,688)	0.3%
SVCW	(13,153,679)	(10,830,847)	(12,961,059)	(12,396,490)	757,189	-5.8%
<b>Operating Income (Loss)</b>	<b>6,154,357</b>	<b>2,881,155</b>	<b>276,301</b>	<b>6,168,697</b>	<b>14,340</b>	<b>0.2%</b>
Non-Operating Rev / Exp	45,000	526,852	520,852	345,000	300,000	666.7%
General Fund	6,199,357	3,408,007	797,154	6,513,697	314,340	5.1%
Capital Fund	250,000	88,490	88,490	250,000	0	0.0%
Solid Waste Fund	5,000	26,579	14,314	(5,090)	(10,090)	-201.8%
<b>Change in Net Position</b>	<b>6,454,357</b>	<b>3,523,075</b>	<b>899,957</b>	<b>6,758,607</b>	<b>304,250</b>	<b>4.7%</b>
Restricted Funds						
Recycled Water Fund	12,630	(694,219)	(752,902)	(752,902)	(765,532)	

### **Recommendation**

The Finance Manager recommends the Board approve the Proposed Budget for Fiscal Year 2021-22.

Attachment: Proposed Budget Report, FY 2021-22

# **WEST BAY SANITARY DISTRICT**



**Proposed Budget**

**Fiscal Year 2021-2022**

## **Financial Report Proposed Budget Fiscal Year 2021-2022**

The West Bay Sanitary District (the District) provides wastewater collection and conveyance services to the City of Menlo Park, Atherton, and Portola Valley, and areas of East Palo Alto, Woodside and unincorporated San Mateo and Santa Clara counties. The District conveys raw wastewater, via the Menlo Park Pump Station and force main, to Silicon Valley Clean Water (SVCW) for treatment and discharge to the San Francisco Bay. The District was originally formed in December 1902 as the Menlo Park Sanitary District under the Sanitary Sewer Act of 1891. The District operated as the Menlo Park Sanitary District from 1902 until 1981 when its name was changed to the West Bay Sanitary District to more accurately reflect the service area. The powers of the District are established by the State of California Health and Safety Code. The District serves a population of 20,170 households and commercial establishments.

The District held a Budget Workshop on May 5, 2021 to work on the development of the fiscal year 2021-2022 (FY 2021-22) Budget. Based on District estimates and direction from the District Board of Directors (Board), the Proposed Budget Report was developed, in conformity with the format prescribed by the provisions of Governmental Accounting Standards. This report is an overview of the District's Proposed Budget for FY 2021-22.

### **Table of Contents**

Statement of Revenue, Expenses and Changes in Net Position	3
Changes since Budget Workshop	4
General Fund	
Revenues	5
Expenditures	6
Expense Analysis	7
Capital Fund	9
Capital Fund Details	11
Reserves	13
Solid Waste Fund	15
Recycled Water Fund	16

West Bay Sanitary District  
Proposed Budget  
Fiscal Year 2021-22

	Budget FY 2020/21	YTD 3/31/2021	Projected 6/30/21	Budget FY 2021/22	Budget Variance	% Var
<b>General Fund</b>						
<b>Operating Revenue</b>						
Non-Residential	6,861,843	5,385,440	7,180,587	5,193,421	(1,668,422)	-24.3%
Residential	23,912,216	18,005,546	23,966,720	24,547,205	634,989	2.7%
Sewer Service Charges	<b>30,774,058</b>	<b>23,390,987</b>	<b>31,147,307</b>	<b>29,740,626</b>	<b>(1,033,432)</b>	<b>-3.4%</b>
Permit & Inspection Fees	100,000	155,419	155,419	100,000	0	0.0%
Flow Equalization Cost Sharing	355,000	355,000	355,000	368,490	13,490	3.8%
Other Operating Income (LAH, WS, HACH)	350,000	391,075	521,433	663,781	313,781	89.7%
<b>Total Operating Revenue</b>	<b>31,579,058</b>	<b>24,292,481</b>	<b>32,179,160</b>	<b>30,872,898</b>	<b>(706,161)</b>	<b>-2.2%</b>
<b>Operating Expenditures</b>						
District Operating Expense (Excluding Depreciation)	9,371,022	8,592,334	16,075,400	9,107,711	(263,312)	-2.8%
Depreciation	2,900,000	1,988,145	2,866,400	3,200,000	300,000	10.3%
SVCW Expense	13,153,679	10,830,847	12,961,059	12,396,490	(757,189)	-5.8%
<b>Total Operating Expenditures</b>	<b>25,424,701</b>	<b>21,411,327</b>	<b>31,902,859</b>	<b>24,704,200</b>	<b>(720,501)</b>	<b>-2.8%</b>
<b>Net Operating Income (Loss)</b>	<b>6,154,357</b>	<b>2,881,155</b>	<b>276,301</b>	<b>6,168,697</b>	<b>14,340</b>	<b>0.2%</b>
<b>Non-Operating Income (Expense)</b>						
Interest Income	50,000	475,231	475,231	350,000	300,000	600.0%
Other Non Operating Income	1,000	51,621	51,621	1,000	0	0.0%
<b>Total Non-Operating Income</b>	<b>51,000</b>	<b>526,852</b>	<b>526,852</b>	<b>351,000</b>	<b>300,000</b>	<b>588.2%</b>
Total Non-Operating Expense	(6,000)	0	(6,000)	(6,000)	0	0.0%
<b>Total Non-Operating Income (Expense)</b>	<b>45,000</b>	<b>526,852</b>	<b>520,852</b>	<b>345,000</b>	<b>300,000</b>	<b>666.7%</b>
<b>Change in Net Position</b>						
Total Income	31,630,058	24,819,333	32,706,012	31,223,898	(406,161)	-1.3%
Total Expenditures	(25,430,701)	(21,411,327)	(31,908,859)	(24,710,200)	720,501	-2.8%
<b>Net Change in Position - Transfer to Capital Fund</b>	<b>6,199,357</b>	<b>3,408,007</b>	<b>797,154</b>	<b>6,513,697</b>	<b>314,340</b>	<b>5.1%</b>
Capital Asset Fund	250,000	88,490	88,490	250,000	0	0.0%
Solid Waste Fund	5,000	1,079	9,179	(5,090)	(10,090)	-201.8%
Recycled Water Fund	12,630	(591,447)	(694,219)	(752,902)	(765,532)	-6061.2%
<b>Total Change in Net Position</b>	<b>6,466,987</b>	<b>2,906,128</b>	<b>200,603</b>	<b>6,005,705</b>	<b>(461,282)</b>	<b>(63)</b>



**Budget Workshop:**

On May 5, 2021, District staff held a Budget Workshop with the Board to review the estimates for FY 2021-22 and receive direction from the Board. The District has also received more current information on some items.

**Changes since Budget Workshop:**

- **General Fund**
  - **Revenue:**
    - Sewer Service Charges increased, since May 5, 2021, based on current data. Revenue is estimated to decrease 2.2%.
  - **Expenditures:**
    - **Salaries & Wages.** Increased based on current rates, added steps, and current data.
    - **Benefits.** Decreased due to payoff of Public Employees Retirement Service (PERS) Unfunded Accrued Liability in FY 2020-21, eliminates contributions in FY 2021-22.
    - **Insurance.** Insurance estimates have been revised based on new information from California Sanitation Risk Management Authority (CSRMA) program administrators. Deductible option were discussed with Finance Committee 6/2/21 and direction provided to increase liability deductible to \$100,000 and reserve \$31,410 savings as a self-insured reserve. Property deductible will remain at \$5,000.
    - **Rents & Leases.** Increased \$6,000 for a lease for the District Manager vehicle.
  - **Interest Income.** Interest was increased from \$250,000 to \$350,000, at direction from the Board.
- **Capital Assets – Vehicles.** At the Board direction, the purchase of a new vehicle for the District Manager has been removed and the lease of a new vehicle for \$6,000 annually has been added Rents & Leases.
- **Reserve Funding.** The Finance Committee reviewed the Reserve Policy on 6/9/21, increasing the Rate Stabilization Reserve to \$10 million, from \$8 million and adding a Treatment Plant Reserve of \$12 million to designate funds for plant capital. The new reserve will allow the District to fund the estimated \$6 million due in 2024, for plant capital and future loan payments. Reserves will be managed in accordance with the revised Reserve Policy.
- **Solid Waste Fund.** Revenue has been reduced to account for increases in costs, based on Board approval of additional route and additional information from Recology, the franchisee.
- **Recycled Water Fund.** Insurance has been increased for the Sharon Heights Recycled Water Facility (SHRWF).

**General Fund:****Revenues:**

The Proposed Budget for FY 2021-22 includes total Operating Revenues of \$30,872,898 in the General Fund, reflecting a 2.2% decrease from FY 2020-21 annual budget.

- **Sewer Service Charges.** Total revenue of \$29,740,626 is estimated for FY 2021-22, reflecting a 24.3% decrease in Non-Residential Sewer Service Charges, irregardless of the 2.5% rate increases. This was due to reduced flows in FY 2020-21 as many business were totally or partially shut down during the COVID-19 pandemic. Residential Sewer Service Charges are estimated to increase 2.7%, due to the 2.5% increase in residential rates.
- **Permit Fees.** Permit & Inspection Fees budget is unchanged at \$100,000. These fees are budgeted conservatively, due to the uncertain nature of their timing and the economic environment.
- **Flow Equal.** The total Flow Equalization Cost Sharing with Silicon Valley Clean Water (SVCW) budget is \$368,490, a 3.8% increase based on the annual Consumer Price Index (CPI) for All Urban Consumers for San Francisco-Oakland-Hayward (Bay Area), CA from April 2020 to April 2021.
- **Other Operating Income.** A total of \$663,781 is estimated; a 90% increase from the FY 2020-21 annual budget, due to negotiated contract extensions with Los Altos Hills and Woodside, and the addition of HACH Service Contract fees, which will be passed-on to customers.
  - Revenue from Los Altos Hills = \$423,775
  - Revenue from Town of Woodside = \$77,106
  - Revenue from HACH Service Contracts = \$162,900
  - Sampling & Monitoring by SVCW is not budgeted for. Receipts are the results of invoices paid to SVCW on behalf of our commercial customers, which the District then bills to our customers.
- **Other Non-Operating Revenues:** The District budgets for Interest Income of \$350,000 and \$1,000 in other miscellaneous non-operating revenue, for a total of \$351,000.

	Budget FY 2020/21	YTD 3/31/2021	Projected 6/30/21	Budget FY 2021/22	Budget Variance	% Var
<b>General Fund</b>						
<b><u>Operating Revenue</u></b>						
Non-Residential	6,861,843	5,385,440	7,180,587	5,193,421	(1,668,422)	-24.3%
Residential	23,912,216	18,005,546	23,966,720	24,547,205	634,989	2.7%
Sewer Service Charges	<b>30,774,058</b>	<b>23,390,987</b>	<b>31,147,307</b>	<b>29,740,626</b>	<b>(1,033,432)</b>	<b>-3.4%</b>
Permit & Inspection Fees	100,000	155,419	155,419	100,000	0	0.0%
Flow Equalization Cost Sharing	355,000	355,000	355,000	368,490	13,490	3.8%
Other Operating Income (LAH, WS, HACH)	350,000	391,075	521,433	663,781	313,781	89.7%
<b>Total Operating Revenue</b>	<b>31,579,058</b>	<b>24,292,481</b>	<b>32,179,160</b>	<b>30,872,898</b>	<b>(706,161)</b>	<b>-2.2%</b>

**Expenditures:**

Total Operating Expenditures for the General Fund is estimated at \$24,704,200, a 2.8% decrease from FY 2020-21.

- **WBSD Direct Operating Expenses.** General Fund Expenses were \$9,107,711, excluding \$3.2 million in Capital Depreciation, a 2.8% decrease from the FY 2020-21 annual budget. Expenses are shown on the Expense Analysis on the following page in total, with allocations to the Solid Waste and Recycled Water Fund deducted in aggregate.
- **Depreciation.** Depreciation increased 10.3% due to \$7.25 million in capital projects completed through March 31, 2021, which are now being depreciated.
- **External Operating Expenses.** This includes contributions and debt payments, for the benefit of, SVCW. Total Expenditures are \$12,396,490 for the District share of SVCW budget in FY 2021-22, a 5.8% decrease, due to lower flows and SVCW refinancing of debt in FY 2020-21 at lower rates. SVCW expenditures represent 57.6% of the total annual budget, excluding depreciation. The District holds a 23.91% share of SVCW's Net Position according to the SVCW's annual Unaudited Analysis of Net Position, as of June 30, 2020. SVCW will be reported as a separate Fund in FY 2021-22, to better identify direct District Operations and those of SVCW.
  - SVCW Operating & Capital Contributions are \$7,163,747. This is a 9.3% decrease from FY 2020-21, due to decreased flows from the District to SVCW for treatment processing while other members realized an increase in flows.
  - SVCW Debt payments are \$5,232,733. The 2014 and 2015 Bonds were refinanced, along with the 2011 SRF debt, into new 2021 Bonds. The District owes \$55.7 million for the new 2021 Bonds, with payments commencing in 2021-22. SVCW refinanced debt to take advantage of historically low rates, which are estimated to save the District \$3.25 million.
    - Additional refinancing is expected to occur in 2021-22, which will affect future debt payments, including the addition of a 2024 Bond,
- **Non-Operating Expenses.** The District budgets \$6,000 for unanticipated Non-Operating Expenses.

**Change in Net Position:**

The General Fund Net Operating Income is estimated at \$6,525,697 for FY 2021-22. This is the estimated amount that will be transferred to the Capital budget for capital projects.

Proposed Budget  
Fiscal Year 2021-22  
General Fund  
Expense Analysis

General Fund Expenditures	Budget FY 2020/21	YTD 3/31/2021	Projected 6/30/21	Budget FY 2021/22	Budget Variance	% Var
<b>Operating Expense</b>						
Salaries & Wages	3,963,828	3,039,858	6,079,716	4,363,442	399,614	10.1%
Employee Benefits	2,841,502	3,967,557	7,935,114	1,834,191	(1,007,311)	-35.4%
<b>Total Salaries, Wages &amp; Benefits</b>	<b>6,805,330</b>	<b>7,007,415</b>	<b>14,014,829</b>	<b>6,197,633</b>	<b>(607,697)</b>	<b>-8.9%</b>
<b>Other Operating Expense</b>						
Director Fees	42,320	29,110	38,813	42,320	0	0.0%
Election Expense	70,000	4	4	0	(70,000)	-100.0%
Depreciation	2,900,000	1,988,145	2,866,400	3,200,000	300,000	10.3%
Gasoline, Oil & Fuel	70,000	31,188	41,584	70,000	0	0.0%
Insurance	173,290	160,838	167,182	204,550	31,260	18.0%
Self-Insurance Reserve				31,410	31,410	
Memberships	51,450	39,012	39,012	58,660	7,210	14.0%
Office Expense	35,500	23,593	31,458	39,600	4,100	11.5%
Operating Supplies	375,345	296,816	395,755	393,425	18,080	4.8%
Contractual Services	481,000	271,652	362,203	665,475	184,475	38.4%
Professional Services	495,220	218,165	290,886	510,220	15,000	3.0%
Printing & Publications	62,500	27,348	60,837	67,500	5,000	8.0%
Rents & Leases	40,000	27,862	37,149	51,700	11,700	29.3%
Repairs & Maintenance	297,900	226,381	301,842	338,425	40,525	13.6%
Research & Monitoring	20,000	6,600	8,800	20,000	0	0.0%
Training, Meetings & Travel	56,200	14,730	19,641	56,200	0	0.0%
Utilities	196,550	174,815	233,086	232,500	35,950	18.3%
LAFCO Contributions	21,000	28,067	19,000	29,400	8,400	40.0%
Other Operating Expense	199,700	88,715	118,287	219,340	19,640	9.8%
Transfer Overhead to Solid Waste Reserve Fund	(103,000)	(68,286)	(85,686)	(105,090)	(2,090)	2.0%
Transfer Overhead to Recycled Water Facility	(19,283)	(11,692)	(19,283)	(15,557)	3,726	-19.3%
<b>Total Other Operating Expenses</b>	<b>5,465,692</b>	<b>3,573,065</b>	<b>4,926,971</b>	<b>6,110,078</b>	<b>644,386</b>	<b>11.8%</b>
<b>Total Operating Expense</b>	<b>12,271,022</b>	<b>10,580,479</b>	<b>18,941,800</b>	<b>12,307,711</b>	<b>36,688</b>	<b>0.3%</b>
<b>Related Agencies:</b>						
<b>Silicon Valley Clean Water (SVCW)</b>						
SVCW Operating Expenditures	7,076,158	5,162,651	6,883,538	6,225,028	(851,130)	-12.0%
SVCW Revenue Funded Capital Expenditures	347,712	260,784	347,712	401,929	54,217	15.6%
SVCW Reserve Contributions	409,274	306,956	409,274	536,800	127,526	31.2%
SVCW 2014 Bond (\$65 million)	1,145,480	1,145,480	1,145,480		(1,145,480)	-100.0%
SVCW 2015 Bond (\$60 million)	1,610,500	1,610,500	1,610,500		(1,610,500)	-100.0%
SVCW 2018 Bond (\$55 million)	1,837,713	1,837,713	1,837,713	1,839,213	1,500	0.1%
SVCW 2021A&B Bond (\$55.6 million)		0		2,743,273	2,743,273	
SVCW SRF - Control Building, C-06-5216-110	220,077	0	220,077	0	(220,077)	-100.0%
SVCW SRF - WWTP Phase I, C-06-5216-120	506,765	506,765	506,765	506,765	0	0.0%
SVCW SRF - Conveyance Planning, C-06-8069-110 (\$4.1m)		0		143,482	143,482	
<b>Total SVCW Expenditures</b>	<b>13,153,679</b>	<b>10,830,847</b>	<b>12,961,059</b>	<b>12,396,490</b>	<b>(757,189)</b>	<b>-5.8%</b>
<b>Total Operating Expenditures</b>	<b>25,424,701</b>	<b>21,411,327</b>	<b>31,902,859</b>	<b>24,704,200</b>	<b>(720,501)</b>	<b>-2.8%</b>

Proposed Budget  
Fiscal Year 2021-22  
General Fund  
Expense Analysis

<b>Salaries, Wages, And Benefit - Details</b>	<b>Budget FY 2020/21</b>	<b>YTD 3/31/2021</b>	<b>Projected 6/30/21</b>	<b>Budget FY 2021/22</b>	<b>Budget Variance</b>	<b>% Var</b>
<b>Salaries &amp; Wages</b>						
Collection	2,197,296	1,675,051	2,233,401	2,308,600	111,304	5.1%
Administrative	1,123,236	990,003	1,320,005	1,345,300	222,065	19.8%
Temporary Employees	160,000	91,330	131,881	130,000	(30,000)	-18.8%
Allowance for Staff Salary Increase July, 4% Per MOU	137,480	0	142,136	143,640	6,160	4.5%
Allowance for Merit Increase (Step Increases)	16,450	0	4,073	61,620	45,170	274.6%
<b>Subtotal</b>	<b>3,634,462</b>	<b>2,756,384</b>	<b>3,831,495</b>	<b>3,989,160</b>	<b>354,698</b>	<b>9.8%</b>
Overtime	142,019	102,595	145,000	154,690	12,671	8.9%
Standy-By Pay	37,347	28,900	33,830	39,520	2,173	5.8%
Performance Measures Program	150,000	142,329	142,329	160,000	10,000	6.7%
End Of Year Compensation	0	9,650	9,650	20,072	20,072	
<b>Total Salaries &amp; Wages</b>	<b>3,963,828</b>	<b>3,039,858</b>	<b>4,162,305</b>	<b>4,363,442</b>	<b>399,614</b>	<b>10.1%</b>
<b>Employee Benefits</b>						
Life & AD&D Insurance	17,372	8,262	11,016	14,175	(3,197)	-18%
Long-Term Disability	20,847	11,545	15,394	19,845	(1,002)	-5%
Workers' Compensation	129,332	82,464	109,952	118,230	(11,102)	-9%
Cafeteria & Health Benefits	907,182	624,353	832,471	1,013,350	106,168	12%
Public Employee's Retirement System (PERS)	414,441	212,664	352,664	355,335	(59,106)	-14%
PERS Unfunded Accrued Liability	2,600,000	2,982,655	6,246,141	0	(2,600,000)	-100%
Employee Assistance & FSA Administration Fee	3,100	831	1,663	1,806	(1,294)	-42%
Social Security, Medicare, State Employer Taxes	85,880	61,735	82,314	85,000	(880)	-1%
District Manager Auto Allowance	7,200	4,385	5,846	6,300	(900)	-13%
Commuter	10,000	2,985	3,979	10,000	0	0%
Deferred Compensation Matching	58,691	37,412	49,883	60,150	1,459	2%
Pre-Funding Retirement Unfunded Liability (PARS Trust)	(1,600,000)	(1,600,000)	(1,600,000)	0	1,600,000	-100%
Pre-Funding OPEB Unfunded Liability (PARS Trust)	87,458	0	87,458	50,000	(37,458)	-43%
Vacation Leave Accrual	100,000	65,585	87,447	100,000	0	0%
<b>Total Employee Benefits</b>	<b>2,841,503</b>	<b>2,494,877</b>	<b>6,286,228</b>	<b>1,834,191</b>	<b>(1,007,312)</b>	<b>-35.4%</b>

**Capital Fund:**

The Capital Fund is funded with any Net Increase in Position from the General Fund Operations, Connection Charges by customers, and Interest Income.

	Budget	YTD	Projected	Budget	Budget	
	FY 2020/21	3/31/2021	6/30/2021	FY 2021/22	Variance	% Var
<b>Fund Balance</b>						
Beginning Balance For Fiscal Year *	20,960,496	20,960,496	20,960,496	20,116,346	(844,150)	-4%
Revenue - Connection Charges	250,000	88,490	88,490	250,000	0	0%
Projected Transfer From General Fund	6,199,357	3,408,007	797,154	6,513,697	314,340	5%
<b>Total Funds Balance Available</b>	<b>27,409,853</b>	<b>24,456,993</b>	<b>21,846,140</b>	<b>26,880,044</b>	<b>(529,810)</b>	<b>-2%</b>
<b>Capital Expenditures</b>	<b>(9,428,000)</b>	<b>(930,466)</b>	<b>(1,729,793)</b>	<b>(12,751,750)</b>	<b>(3,323,750)</b>	<b>35%</b>
<b>Fund Balance</b>	<b>17,981,853</b>	<b>23,526,526</b>	<b>20,116,346</b>	<b>14,128,294</b>	<b>(3,853,560)</b>	<b>-21%</b>

**Capital Fund Revenue:**

Connection Fees of \$250,000 are estimated; no change from FY 2020-21.

**Capital Fund Expenses:**

Total Capital Expenditures of \$12,751,750 are budgeted for in FY 2021-22; 36% increase from FY 2020-21. A detailed schedule of Capital Expenditures is included on page 11-12.

	Budget	YTD	Projected	Budget	Budget	
	FY 2020/21	3/31/2021	6/30/2021	FY 2021/22	Variance	% Var
<b>Capital Expenditures</b>						
Administration	35,000	0	32,000	35,000	0	0%
Collection Facilities	100,000	2,800	2,800	600,000	500,000	500%
Vehicles & Equipment	228,000	177,112	212,112	201,750	(26,250)	-12%
Subsurface Lines & Other Capital	195,000	0	94,983	195,000	0	0%
Construction Projects	8,870,000	750,554	1,387,898	11,720,000	2,850,000	32%
<b>Total Capital Expenditures</b>	<b>9,428,000</b>	<b>930,466</b>	<b>1,729,793</b>	<b>12,751,750</b>	<b>3,323,750</b>	<b>35%</b>

- **Administration.** The budget for Administrative facilities is \$35,000, no change from FY 2020-21.
- **Collection Facilities - Buildings.** The budget for Collection includes FERRF Improvements and Allowance for Unanticipated Capital Expenditures of \$600,000, a 500% increase from the \$100,000 in FY 2020-21 budget.
  - FERRF Improvements: Added \$500,000 in FY 2021-22.
  - Allowance For Unanticipated Capital Expenditures: \$100,000; No Change in FY 2021-22.

- **Vehicle & Equipment.** The budget for vehicles and equipment is \$261,750, a 15% increase over FY 2020-21 budget.
  - Equipment:
    - Flo Dar Equipment: Increase 5% to \$36,750 for two flow meters, due to price increase.
  - Vehicles: Increase expenditures 62% in FY 2021-22.
    - Replace Vehicle 201, District Manager vehicle.
      - Lease Malibu at \$500 month, included in Rents & Leases
    - Add Vehicle 228, Jet Truck, Superduty F550 4x4, 1/2in Jetter.
  - Contribution to Equipment Replacement Reserve: Increase 3%.

	Budget	Actual	Projected	Budget	Variance	YTD %
Vehicle Replacement Program	FY 2020-21	3/31/2021	6/30/2021	FY 2021/22	Budget Balance	Budget
Bank of the West Money Mkt, Less Contributions	607,251	607,251	607,251	757,441	150,190	25%
Interest	-	1,286	1,802	1,666	1,666	
Contributions	360,500	360,500	360,500	371,315	10,815	3%
Total Vehicle & Equipment Expenditures	(228,000)	(177,112)	(212,112)	(201,750)	26,250	-12%
<b>Net Vehicle &amp; Equipment Program</b>	<b>739,751</b>	<b>791,925</b>	<b>757,441</b>	<b>928,672</b>	<b>188,921</b>	<b>26%</b>

- **Subsurface Lines & Other Capital.** The budget is unchanged from FY 2020-21, at \$195,000.
- **Construction in Progress (CIP).** These are new constructions projects that are recorded separately and capitalized when completed. CIP is not depreciated until completed. \$11,720,000 is budgeted for CIP, with \$6.6 million carried over from FY 2020-21 capital budget.
- **Resource Recovery.** Recycled water facilities projects recorded under the Recycled Water Fund.
  - **Sharron Heights Recycled Water Facility.** The facility is completed and there is no capital improvements budgeted in FY 2021-22.
  - **Bayfront.** The proposed Bayfront Recycled Water Project is in early developments. \$1 million is budgeted for entrance improvements.

Proposed Budget  
Fiscal Year 2021-22  
Capital Fund

Capital Expenditure - Detail	Budget FY 2020/21	YTD 3/31/2021	Projected 6/30/2021	Budget FY 2021/22	Budget Variance	% Var
<b>Administration</b>						
District Office Interior	10,000		9,000	10,000	0	0%
District Office Exterior	10,000		8,000	10,000	0	0%
Server Replacement Program	15,000		15,000	15,000	0	0%
10 Year Master Plan - Deferred	0			0	0	
<b>Total Administration</b>	<b>35,000</b>	<b>0</b>	<b>32,000</b>	<b>35,000</b>	<b>0</b>	<b>0%</b>
<b>Collection Facilities</b>						
FERRF Improvements	0	0	0	500,000	500,000	
Allowance For Unanticipated Capital Expenditure	100,000	2,800	2,800	100,000	0	0%
<b>Subtotal Collection Facilities</b>	<b>100,000</b>	<b>2,800</b>	<b>2,800</b>	<b>600,000</b>	<b>500,000</b>	<b>500%</b>
<b>Equipment Replacement - Funded From The Equipment Replacement Fund</b>						
<b>Equipment</b>						
Ads Flow Meter	0				0	
Pipehunter (Hoses & Camera Reel Backups)	25,000	23,250	23,250		(25,000)	-100%
Mainline CCTV Camera	28,000	23,835	23,835		(28,000)	-100%
Flo Dar Equipment (Flow Meters)	35,000		35,000	36,750	1,750	5%
<b>Vehicles</b>						
District Manager Vehicle (2013) - Unit 201				0	0	
Dump Truck (Deferred since 2020 to 2023-24) - Unit 203					0	
Jet Truck, Superduty F550 4x4, 1/2in Jetter - Unit 228				165,000	165,000	
Operations Superintendent SUV - Unit 206					0	
Pump Supervisor Truck, 1/2ton Crane (Deferred I	90,000	87,290	87,290		(90,000)	-100%
Service Truck - Unit 208					0	
Water Quality Supervisor Vehicle - Unit 227	50,000	42,738	42,738		(50,000)	-100%
<b>Total Equipment Replacement</b>	<b>228,000</b>	<b>177,112</b>	<b>212,112</b>	<b>201,750</b>	<b>(26,250)</b>	<b>-12%</b>
Equipment purchases funded from Equipment Re	(360,500)	(177,112)	(360,500)	(371,315)	(10,815)	3%
<b>Net Vehicles &amp; Equipment</b>	<b>328,000</b>	<b>179,912</b>	<b>(145,588)</b>	<b>801,750</b>	<b>473,750</b>	<b>144%</b>
<b>Subsurface Lines &amp; Other Capital</b>						
<b>Pump Stations</b>						
Pump & Valve Replacement Program	40,000		40,000	45,000	5,000	13%
Private Pump & Panel Replacements	20,000		20,000	15,000	(5,000)	-25%
Pump Station Repair & Replacements	5,000		0	5,000	0	0%
<b>Total Pump Stations</b>	<b>65,000</b>	<b>0</b>	<b>60,000</b>	<b>65,000</b>	<b>0</b>	<b>0%</b>
Flow Monitoring Study	30,000		25,000	30,000	0	0%
Smart Covers (2)	0		9,983	0	0	
Manhole Raising (Paving Projects)	100,000		0	100,000	0	0%
<b>Total Subsurface Lines and Other</b>	<b>195,000</b>	<b>0</b>	<b>94,983</b>	<b>195,000</b>	<b>0</b>	<b>0%</b>



Proposed Budget  
Fiscal Year 2021-22  
Capital Fund

Capital Expenditure - Detail	Budget FY 2020/21	YTD 3/31/2021	Projected 6/30/2021	Budget FY 2021/22	Budget Variance	Budget % Var
<b><u>Construction in Progress</u></b>						
Levee Survey & GPS Update	60,000	0	0	60,000	0	0%
FERRF & Levee Improvement Project - Sheet Piling	1,500,000	293,521	293,521	6,000,000	4,500,000	300%
Sheet Piling Projects	0				0	
Corporate Yard Renovation Feasibility Study / Desi	350,000			350,000	0	0%
Replace Metal Storage Building Phase 1	852,550		50,000	852,550	0	0%
Replace Metal Storage Building Phase 2	247,450			247,450	0	0%
Construction Projects Environmental Review	10,000			10,000	0	0%
<b><u>Pipeline Replacement &amp; Rehab Engineering</u></b>					0	
<i>Isabella, Gilbert &amp; Bay North, Coyote Hill - Phase 1</i>	350,000				(350,000)	-100%
<b><u>Pipeline Replacement &amp; Rehab Construction</u></b>					0	
<i>Belle Haven III &amp; Alpine</i>		39,647			0	
<i>Town of Atherton Civic Center - Dinklespeil</i>	0				0	
<i>Isabella, Gilbert &amp; Bay North - Phase 1 (Carryover ;</i>	1,500,000	373,100	1,000,000		(1,500,000)	-100%
<i>Isabella, Gilbert &amp; Bay North - Phase 2 (Carryover</i>	2,500,000			2,500,000	0	0%
<i>Lower Ringwood / North Bay (Carryover \$1.5m)</i>	1,500,000			1,500,000	0	0%
<i>Stowe Lane</i>	0			200,000	200,000	
<b>Total Construction in Progress</b>	<b>8,870,000</b>	<b>750,554</b>	<b>1,387,898</b>	<b>11,720,000</b>	<b>2,850,000</b>	<b>32%</b>
<b>Total Operating Capital Expenditures</b>	<b>9,428,000</b>	<b>930,466</b>	<b>1,729,793</b>	<b>12,751,750</b>	<b>3,323,750</b>	<b>35%</b>
<b>Resource Recovery Projects</b>						
Bayfront Resource Recovery	300,000	0	247,398	0	(300,000)	-100%
Bayfront Entrance Improvements				1,000,000	1,000,000	
<b>Recycled Water Facilities</b>	<b>300,000</b>	<b>0</b>	<b>247,398</b>	<b>1,000,000</b>	<b>700,000</b>	<b>2.33</b>
<b>Total Capital Expenditures</b>	<b>9,728,000</b>	<b>930,466</b>	<b>1,977,191</b>	<b>13,751,750</b>	<b>4,023,750</b>	<b>52%</b>

**Reserves:**

The District reserves funds to protect cash flow between sewer service fee payments from the county, maintain fiscal stability, and reserve for future projects. The District has six individual investment accounts to reserve funds for various aspects of operations, plus two money market accounts, including the two accounts which are restricted and hold deposits from Sharon Heights Golf & Country Club (SHGCC) for the SRF loan on the Sharon Heights Recycled Water Facility (SHRWF). In addition, the District has two checking accounts and holds funds in Local Agency Investment Fund (LAIF), which are liquid and available to fund current Operations and Capital Projects.

**Proposed Budget  
Fiscal Year 2021-22  
Reserves**

	Target	Balance 6/30/2020	Contributions, (Withdrawals), Change in Value 2020/21	Projected Balance 6/30/2021	Budget Contributions (Withdrawals) 2021/22	Projected Balance 6/30/2022
<b>General Fund</b>						
Operating Reserve (in LAIF, effective 6/9/21)	10,752,100	9,530,903	0	9,530,903	1,221,197	10,752,100
Rate Stabilization	10,000,000	1,408,407	8,580,432	9,988,840	0	9,988,840
Treatment Plant Reserve (transferred from Ops)	12,000,000		0	0	2,500,000	2,500,000
PARS Irrevocable Trust - OPEB		273,733	126,672	400,405	50,000	450,405
PARS Irrevocable Trust - Retirement		1,762,989	(1,535,170)	227,819	0	227,819
Local Agency Investment Fund (LAIF)		21,999,036	(9,319,181)	12,679,855	200,000	12,879,855
<b>Total General Fund</b>		<b>34,975,069</b>	<b>(2,147,247)</b>	<b>32,827,822</b>	<b>3,971,197</b>	<b>36,799,019</b>
<b>Capital Asset Fund</b>						
Emergency Capital Reserve	5,000,000	3,904,702	1,083,608	4,988,310	0	4,988,310
Capital Project Reserve	6,000,000	2,781,875	3,208,412	5,990,287	0	5,990,287
Equipment Replacement Reserve		607,251	274,496	881,747	371,315	1,253,062
Local Agency Investment Fund (LAIF)		6,753,129	2,531,272	<b>9,284,401</b>	(5,988,053)	3,296,348
<b>Total Capital Asset Fund</b>		<b>14,046,958</b>	<b>7,097,788</b>	<b>21,144,745</b>	<b>(5,616,738)</b>	<b>15,528,007</b>
<b>Recycled Water Fund</b>						
Recycled Water Cash Flow Reserve	8,000,000					
Recycled Water Facility Cash Flow Reserve - BoW		228,464	1,012	229,476	400,000	629,476
Recycled Water Facility Cash Flow Reserve - LAIF		7,313,135	31,724	7,344,859	33,400	7,378,259
<b>Total Recycled Water Cash Flow Reserve</b>		<b>7,541,598</b>	<b>32,737</b>	<b>7,574,335</b>	<b>433,400</b>	<b>8,007,735</b>
<b>Restricted Accounts</b>						
Recycled Water SRF Reserve (Required Deposit)	1,458,404					
Recycled Water SRF Reserve - BofW Investment Acct.		1,530,350	(1,282,147)	248,203	0	248,203
Recycled Water SRF Reserve - BofW MM Acct.			1,282,147	1,282,147	0	1,282,147
<b>Total Recycled Water SRF Reserves</b>		<b>1,530,350</b>	<b>0</b>	<b>1,530,350</b>	<b>0</b>	<b>1,530,350</b>
<b>Total Recycled Water Fund</b>		<b>9,071,948</b>	<b>32,737</b>	<b>9,104,685</b>	<b>433,400</b>	<b>9,538,085</b>
<b>Solid Waste Fund</b>						
Solid Waste Rate Stabilization		243,405	8,760	252,165	(5,090)	247,075

**Reserves:**

District staff met with the Finance Committee on June 2, 2021 to discuss options to achieve the reserve target balances. After direction from the Finance Committee and if authorized by the full Board at the June 9, 2021 Board meeting, the District will create a new Treatment Plant Reserve, with a target of \$12 million. In addition, the Operating Reserve Investment Account will fund the target balance deficits and Operating Reserves will be kept in LAIF, where funds are readily available.

To fully fund all targets, plus the annual contribution to the Equipment Reserve, the District would need \$13.6 million designated to reserves. Based on the estimated LAIF balance, as of 6/30/21 and estimated budget for FY 2021-22, there would be \$7.8 million in unreserved funds.

- **Reserves.** Total reserve designations and transfers are \$4.1 million in FY 2021-22.
  - **Operating Reserve:** Designate \$1,221,197
    - Six months of operations provides cash flow between July and December, when the first sewer service charges are received.
    - Operating Reserves will be held in LAIF, where they are available for cash flow.
  - **Treatment Plant Reserve:** \$2,500,000
    - The District estimates funding reserve \$2.5 million annual.
    - In 2024 the District anticipates the need for \$6 million to avoid further SVCW bonds at \$416,000 per year for 30 years, for a total of \$12.48 million. Additionally, in FY 2027-28 annual SVCW debt service will increase by \$2.6 million.
  - **Other Post-Employment Benefits:** \$50,000 to keep pace with increasing liability.
  - **Vehicle & Equip Replacement Reserve:** \$371,315, increased 3% annually.
- **Restricted Reserves.** There is no budget for transfers to restricted reserve accounts.

Reserves	Budget FY 2020/21	YTD 3/31/2021	Projected 6/30/2021	Budget FY 2021/22	Budget Variance	% Var
<b>Reserve Contributions</b>						
Operating Reserves Transfers (Target Goal \$9.5M)	1,300,000	0	(7,560,000)	1,221,197	(78,803)	-6%
Rate Stabilization/Bond Reserve (Target Goal \$1M)	1,555,000	1,555,000	8,592,000	0	(1,555,000)	-100%
Treatment Plant Reserve (Target Goal \$12M)				2,500,000	2,500,000	100%
<b>Capital Reserves</b>						
Capital Project Reserves Transfers (Target Goal \$1M)	683,500	683,500	3,205,500	0	(683,500)	-100%
Emergency Capital Reserves Transfer (Target Goal \$1M)	200,000	200,000	1,075,000	0	(200,000)	-100%
Vehicle & Equip Replacement Reserve	360,500	360,500	360,500	371,315	10,815	3%
Recycled Water Cash Flow Reserve (Target Goal \$8M)		0	426,000	0	0	
<b>Recycled Water - Restricted Reserves</b>						
Recycled Water SRF Reserve						
<b>Total Reserve Contributions</b>	<b>4,099,000</b>	<b>2,799,000</b>	<b>6,099,000</b>	<b>4,092,512</b>	<b>(6,488)</b>	<b>0%</b>

**Solid Waste:**

The Solid Waste Fund has a net decrease of \$5,090, a \$10,000 change from FY 2021-22. The Fund will have a Net Position of \$247,494.

- **Solid Waste Fund Revenue.** Franchise fees are received from Recology, which manages solid waste collection for the District. The budget is estimated at an 18% increase from FY 2020-21. The budget is based on average for FY 2020-21, less a slight decrease, due to the introduction of a new route in 2022. In addition, Recology has other changes, which are uncertain at this time; additional costs associated with implementation of California’s Short-Lived Climate Pollutant (SLCP) Reduction Strategy, SB 1383 and disposal costs at the Shoreway Environmental Center.
- **Solid Waste Fund Expense.** Allocated expenses for the Solid Waste program of \$105,090 is budgeted for rate studies, annual notification mailing, and overhead allocation. The annual Rate Study is based on the contract for this service, although it is 34% under budget for FY 2020-21. The overhead to manage the Fund has increased by the Consumer Price Index of 3.8%, for the Bay Area, as of April 2021.

Proposed Budget  
Fiscal Year 2021-22  
Solid Waste Fund

	Budget FY 2020/21	YTD 3/31/2021	Projected 6/30/21	Budget FY 2021/22	Budget Variance	% Var
<b>Operating Income</b>						
Franchises	108,000	69,365	94,865	100,000	(8,000)	-7%
<b>Total Income</b>	<b>108,000</b>	<b>69,365</b>	<b>94,865</b>	<b>100,000</b>	<b>(8,000)</b>	<b>-7%</b>
<b>Expenditures</b>						
Rate Studies	42,000	25,105	27,755	42,000	0	0%
Mailings	5,000	1,932	1,932	5,000	0	0%
Public Relations	1,000	0	1,000	1,000	0	0%
Overhead Expense Allocation - General Func	55,000	41,250	55,000	57,090	2,090	4%
<b>Total Allocated Operating Expense</b>	<b>103,000</b>	<b>68,286</b>	<b>85,686</b>	<b>105,090</b>	<b>2,090</b>	<b>2%</b>
<b>Solid Waste Fund Beginning Balance</b>	<b>243,405</b>	<b>243,405</b>	<b>243,405</b>	<b>252,584</b>	<b>9,179</b>	<b>4%</b>
<b>Contribution To Solid Waste Fund</b>	<b>5,000</b>	<b>1,079</b>	<b>9,179</b>	<b>(5,090)</b>	<b>(10,090)</b>	<b>-202%</b>
<b>Solid Waste Fund Balance</b>	<b>248,405</b>	<b>244,484</b>	<b>252,584</b>	<b>247,494</b>	<b>(911)</b>	<b>0%</b>

**Recycled Water:*****Sharon Heights Recycled Water Facility***

The Sharon Heights Recycled Water Facility (SHRW) was completed in FY 2021-22, for a project total of \$22,647,052. \$22,267,257 has been received from the State Revolving Fund, including a \$5,259,800 Water Recycling Funding Program Construction Grant and a net SRF Loan of \$17,117,420. The District assumed full management of the facility beginning January 27, 2021.

Summary Recycled Water Fund statements are included on page 17-18, with detailed expenditure schedule on page 16.

- **Revenue.** All costs of the facility are paid by the District and ultimately paid by Sharon Heights Golf & Country Club (SHGCC). The budget for FY 2021-22 is \$511,266 in revenue, which represents reimbursement by SHGCC. The District provided SHGCC with a projected budget in January 2021, which estimates \$444,391 annually and is billed in monthly equal installments. The difference will be reconciled annually and billed to SHGCC.
- **Expense.** Total Operating expenditures are estimated at \$1,264,761 for FY 2021-22, including \$754,902 in depreciation of the recycled water facility.
  - Operating Expenses were \$494,303.
    - Direct District expenses are budgeted at \$494,303, 27% less than FY 2020-21.
      - Insurance is 171% higher than the FY 2020-21 budget and 71% higher than the actual for FY 2020-21; liability decreased 2%, as the District increased our deductible to \$100,000 from \$25,000 and property increased by 50%.
    - Indirect Administration is \$15,557, 19% less than FY 2020-21.
    - There is no outside Operations & Maintenance in FY 2021-22.
    - Depreciation expense is \$754,902 for FY 2021-22.
  - Non-Operating Income & Expenses offset, with net zero for the District.
    - Non-Operating Income is \$664,911, representing \$2,000 in estimated interest income on the SRF deposit and \$662,911 for the SRF loan payment.
    - Non-Operating Expenses of \$662,911 represent the principal and interest on the SRF loan payment.

***Bayfront Recycled Water Project***

The Bayfront Project has a \$1 million capital budget for entrance improvements.

West Bay Sanitary District  
Recycled Water Fund  
Sharron Heights Recycled Water Facility  
Budget Fiscal Year 2021-22

	Budget FY 2020/21	YTD 3/31/2021	Projected 6/30/21	Budget FY 2021/22	Budget Variance	% Var
<b>Fund Income</b>						
Operating Income						
Sharon Heights Golf & Country Club	762,701	457,752	647,620	509,860	(252,841)	-33%
<b>Total Operating Income</b>	<b>762,701</b>	<b>457,752</b>	<b>647,620</b>	<b>509,860</b>	<b>(252,841)</b>	<b>-33%</b>
<b>Fund Expenditures</b>						
Total Operating Expense (Excluding Depreciation)	762,701	528,680	647,620	509,860	(252,841)	-33%
Depreciation	0	521,101	694,801	754,902	754,902	100%
<b>Total Fund Expenditures</b>	<b>762,701</b>	<b>1,049,780</b>	<b>1,342,421</b>	<b>1,264,761</b>	<b>502,061</b>	<b>66%</b>
<b>Non-Operating Income (Expense)</b>						
Non-Operating Income	675,541	663,492	663,492	664,911	(10,630)	-2%
Non-Operating Expense	(662,911)	(662,911)	(662,911)	(662,911)	0	0%
<b>Total Non-Operating Income</b>	<b>12,630</b>	<b>582</b>	<b>582</b>	<b>2,000</b>	<b>(10,630)</b>	<b>-84%</b>
<b>Change in Net Position</b>	<b>12,630</b>	<b>(591,447)</b>	<b>(694,219)</b>	<b>(752,902)</b>	<b>(765,532)</b>	<b>-6061%</b>
<b>RETAINED FUNDS</b>						
<b>Restricted</b>						
SRF Reserve (120% of annual pmt)		863,111	863,111	0	0	
Long Term Agreement Reserve		675,541	675,541	0	0	
Subtotal Restricted Funds	0	1,538,652	1,538,652	0	0	
<b>Unrestricted</b>						
Sinking Fund (Prepaid Rehabilitation Expenses)	144,148	0	0	0	(144,148)	
SRF Advances		878,203	1,077,076	662,911		
Subtotal Restricted Funds	144,148	878,203	1,077,076	662,911	(144,148)	
<b>Retained Funds</b>	<b>288,296</b>	<b>\$3,295,058</b>	<b>3,692,805</b>	<b>1,325,822</b>	<b>(288,296)</b>	

West Bay Sanitary District  
Recycled Water Fund  
Sharron Heights Recycled Water Facility  
Budget Fiscal Year 2021-22

Fund Expenditures - Detail	Budget FY 2020/21	YTD 3/31/2021	Projected 6/30/21	Budget FY 2021/22	Budget Variance	% Var
<b>Operating Expense</b>						
Salaries & Wages	63,428	62,102	82,803	122,992	59,565	94%
Employee Benefits	47,571	19,448	25,931	47,571	0	0%
Indirect Labor	0	0	29,817	29,817	39,756	
<b>Total Salaries, Wages &amp; Benefits</b>	<b>110,999</b>	<b>81,550</b>	<b>138,550</b>	<b>200,381</b>	<b>99,321</b>	<b>89%</b>
<b>Other Operating Expense</b>						
Gasoline, Oil And Fuel	0	0	0	0	0	
Insurance	9,252	10,998	14,664	25,095	15,843	171%
Memberships	0	0	0	0	0	
Office Expense	0	0	0	0	0	
Operating Supplies	4,800	734	978	12,600	7,800	163%
Contractual Services	0	0	0	0	0	
Professional Services	34,992	695	927	10,000	(24,992)	-71%
Printing And Publications	0	0	0	0	0	
Rents And Leases	0	0	0	0	0	
Repairs And Maintenance	12,000	0	0	12,000	0	0%
Research And Monitoring	66,000	2,760	3,680	27,375	(38,625)	-59%
Training, Meetings & Travel	0	0	0	0	0	
Utilities	126,792	128,044	170,726	194,352	67,560	53%
Licenses & Permits	0	19,214	25,619	12,500	12,500	
Other Operating Expenses	33,499	601	802	0	(33,499)	-100%
<b>Subtotal Operating Expenses</b>	<b>398,334</b>	<b>244,596</b>	<b>355,946</b>	<b>494,303</b>	<b>105,907</b>	<b>27%</b>
Operations & Maintenance - Anderson Pacific **	345,083	272,392	272,392	0	(345,083)	-100%
Administrative Expense	19,283	11,692	19,283	15,557	(3,726)	-19.32%
Depreciation	0	521,101	694,801	754,902	754,902	#DIV/0!
<b>Total Operating Expense</b>	<b>762,701</b>	<b>1,049,780</b>	<b>1,342,421</b>	<b>1,264,761</b>	<b>512,000</b>	<b>67%</b>
<b>Non-Operating Income &amp; Expense</b>						
<b>Other Non-Operating Income</b>						
Interest Income, Gains on Investments		581	581	2,000	2,000	
SRF Loan Payments - SHGCC	675,541	662,911	662,911	662,911	(12,630)	-2%
<b>Total Non-Operating Income</b>	<b>675,541</b>	<b>663,492</b>	<b>663,492</b>	<b>664,911</b>	<b>(10,630)</b>	<b>-2%</b>
<b>Other Non-Operating Expense</b>						
SRF Loan Payment - Principal	(501,038)	(443,928)	(443,928)	(496,747)	4,291	-1%
SRF Loan Payment - Interest	(161,873)	(218,983)	(218,983)	(166,164)	(4,291)	3%
<b>Total Non-Operating Expense</b>	<b>(662,911)</b>	<b>(662,911)</b>	<b>(662,911)</b>	<b>(662,911)</b>	<b>(0)</b>	<b>0%</b>
<b>Total Non-Operating Income &amp; Expense</b>	<b>12,630</b>	<b>582</b>	<b>582</b>	<b>2,000</b>	<b>(10,630)</b>	<b>-84%</b>
<b>Total Current Expense</b>	<b>1,425,611</b>	<b>1,712,691</b>	<b>2,005,332</b>	<b>1,927,672</b>	<b>512,000</b>	<b>36%</b>

**RESOLUTION NO. \_\_\_\_\_ (2021)**

IN THE DISTRICT BOARD OF THE WEST BAY SANITARY DISTRICT

COUNTY OF SAN MATEO, STATE OF CALIFORNIA

\*\*\*\*\*

BE IT RESOLVED that the annexed Fiscal Year 2021/2022 General Fund, Capital Assets Fund, Recycled Water Fund, and Solid Waste Fund Budgets, for West Bay Sanitary District is hereby approved.

\*\*\*\*\*

Passed and adopted by the District Board of the West Bay Sanitary District at a regular meeting thereof held on the 9<sup>th</sup> day of June, 2021, by the following vote:

Ayes:

Noes:

Abstain:

Absent:

---

President of the District Board of the West Bay Sanitary District of San Mateo County, State of California

Attest:

---

Secretary of the District Board of the West Bay Sanitary District of San Mateo County, State of California





## WEST BAY SANITARY DISTRICT AGENDA ITEM 12

**To:** *Board of Directors*

**From:** *Sergio Ramirez, District Manager*

**Subject:** *June 9<sup>th</sup>, 2021 Update Report on District Response to Corona Virus*

---

### **Background**

In early March of 2020, the outbreak of Corona Virus in the USA caused Federal, State and Local governments to enact several laws, regulations and guidelines to mitigate the impact of the spread and severity of the virus including Shelter in Place. The District has been busy employing measures to meet those regulations and guidelines as well as taking action to ensure the safe working conditions of staff and minimize exposure of and interaction with the public.

### **Analysis**

The District has thus far taken action in regards to: Shelter in Place, Social Distancing, Personal Protective Equipment, and the Injury and Illness Prevention Program (IIPP).

*Shelter in Place:* The District as a wastewater agency has been designated as an “Essential Service” and supplied employees with letters drafted by legal counsel that can be shown to legal authorities, if required, to justify their travel to, during and from work. In addition, the District has developed a Modified Work Schedule that requires individuals to stay at home or telecommute in order to reduce interaction and thus the potential of any spread of the virus among District staff. The District has also implemented the use of Zoom for meetings to reduce the need for consultants, partners, the public and Board member to attend in person. A camera and large screen have been installed to accommodate this mode of virtual meetings.

*Social Distancing:* District staff has employed several measures related to Social Distancing including; limiting meeting size to 10, marking seating spots at tables with 6 foot separation, signage encouraging 6 foot distancing, separation of reporting stations to include the FERRF, Plexi-glass shields at the counter and between workspaces that cannot achieve 6 foot distancing, and closing of the District Office to the public unless by appointment.

---

**Report to the District Board for the Regular Meeting of June 9, 2021**

*Personal Protective Equipment (PPE):* The District has been engaged in supplying employees and Board members with several forms of Personal Protective Equipment and emphasizing the frequent and regular use of this equipment. These items include: The distribution of hand sanitizer to employees and Board members, wipes for counters, chairs and tables, installation of hand sanitizer at counter, tables and offices, N95 masks to all employees, increased counts coveralls, face shields, goggles etc.

This has caused the District to reassess its inventory and at what levels of existing stock should trigger new orders so that the District can maintain adequate levels of important supplies to carry us not only through traditionally thought of natural disasters but pandemics such as this. To that end staff has developed an improved inventory check list that includes contact information for ordering, expected lag times in ordering, minimum levels of stock, Trigger-levels for ordering, dates of stock added to inventory and so on. This should help us be better prepared for future events where PPE can be in short supply or difficult to obtain and District operations can continue uninterrupted.

*Injury and Illness Prevention Program:* The District has made a significant effort in the way of training employees in how to deal with the COVID 19 response. We have developed SOP's for both field staff and office staff in dealing with customers while maintaining social distancing, utilizing PPE, and remote permitting etc. We have complied with local health officials requirement to complete and post at all entrances the Social Distancing Protocols and used that and our SOP's as a basis for developing a comprehensive COVID 19 Preparedness and Response program.

The District has taken great efforts to inform the public of changes in business procedures during this time including website postings, posting notices and information on all entrance doors, mailings of letters and flyers to residents, and ads in Facebook and YouTube. The use of Wipes has emerged as a huge problem for the District and our outreach has included addressing this problem in the flyers, ads, and correspondence to persuade our constituents to refrain from flushing wipes.

*May 13 update:* The District has found that it takes at least 3 weeks from the date of order to delivery of consumable PPE items such as; N95 face masks (we have received 2,000 masks since the first March order), 500 face shields, and 150 goggles to protect the field staff from droplets and mist while cleaning the sewer lines.

The District will now be faced with transitioning back to normal operations. The District Office is open on Friday by appointment only. Construction activities are increasing and inspections are being scheduled much more frequently. Social Distancing and PPE will continue to be key elements of District life for the foreseeable future.

*May 27 update:* The District has opened the office to the public on Tuesdays and Thursdays. Stickers on the floors and notices on the doors and shields at the counters have been placed to remain compliant with the Health Dept. Wipes and signs have been placed in the bathrooms. All the departments except Administration have

returned to normal work hours (which are mostly 9/80 schedule but crews are still separated with the Satellite Office/Corp Yard. As a result of these changes have updated the COVID 19 response plan and affixed to entry doors as required.

*June 10 update:* Staff is resuming normal Pre-COVID 19 work schedules beginning June 8, with the exception of some of the Admin staff. Office hours will open up to Monday through Thursday 9am to 3pm.

*June 24 update:* As of Friday, June 12 the Administration Office was open by appointment. Office hours continue to be open Monday through Thursday 9am to 3pm. Staff is continuing to make a concerted effort to be available to the public and contractors for business.

*July 8 update:* The current YouTube advertisement advising customers not to flush wipes or towels has been viewed by 220,653 people and 24% or 50,759 have viewed the video to completion.

*August 12 update:* When an employee has been in contact with a known or possible COVID 19 positive patient or been in contact with someone who has been in contact with a confirmed COVID 19 positive patient they will be asked to stay home for a 14-day self-quarantine period and will be asked to be tested for COVID 19. If the employee is well enough during the self-quarantine period, they will work from home during this time. As soon as the employee is COVID 19 negative, they will be asked to return to work.

*September 9 update:* The District's COVID-19 Preparedness and Response Program has been updated through DuAll Safety to include usage of current San Mateo County Health Department signage, updated social distancing protocol (verbiage and links for continuing SIP order), CDC updates on Coronavirus symptoms, addition of cloth face mask and San Mateo County Health guidelines. Training to be scheduled for September with DuAll Safety (by ZOOM) for all current updates. Staff has purchased two disinfecting fog machines to disinfect surfaces in the Admin and Maintenance Buildings, and Operations Building at FERFF. Disinfection of surface are being done weekly.

*September 23 update:* Two employees are currently out sick and in quarantine due to a possible exposure to COVID-19 per District's protocol memorialized in our August 12, 2020 update (above) "*When an employee has been in contact with a known or possible COVID 19 positive patient or been in contact with someone who has been in contact with a confirmed COVID 19 positive patient they will be asked to stay home for a 14-day self-quarantine period and will be asked to be tested for COVID 19.*" Once the employees test negative for COVID-19, or quarantine for 14 days, they will be allowed back to work.

*October 14 update:* No updates at this time.

*October 28 update:* Updated training on the Response Program will be conducted in October. Two office employees were experiencing COVID-19 symptoms and were asked to work from home until test results were available. Both employees tested negative and have returned to work.

*November 18 update:* Updated training on the Response Program will be conducted on November 16.

*December 9 update:* The District is following all County of San Mateo increased COVID-19 restrictions and has cancelled our Holiday Luncheon out of an abundance of caution.

*January 13, 2021 update:* The front office is now limiting customers inside the lobby to no more than one. Others are asked to socially distance outside while they wait. Staff is working on the new COVID-19 Prevention Emergency Temporary Standards regarding prevention and reporting outbreaks.

*January 27, 2021 update:* The new COVID-19 Prevention Plan is complete and staff will receive training shortly.

*February 10, 2021 update:* Updated training on the Response Program was provided on February 2.

*February 24, 2021 update:* District Manager issued COVID-19 Vaccine letter to staff so they may schedule their vaccine on or after February 22, 2021 as part of the Phase 1B.

*March 10, 2021 update:* To date 7 employees have received at least one vaccine shot and approximately 3 others have received appointments.

*March 24, 2021 update:* Approximately 10 employees have been vaccinated.

*April 14, 2021 update:* The front office is back open to the public with limited hours of 9am-3pm Monday thru Friday with one customer being allowed in the lobby at a time. All four front office staff have received their second vaccine. Approximately, 33% of all staff have received one or more vaccine shots.

*April 28, 2021 update:* Approximately 50% of West Staff has been vaccinated. Effective May 3<sup>rd</sup> the Administrative staff will begin to work in the office full time, rather than from home, as they were for one to two days per week.

*May 12, 2021 update:* West Bay staff is back to working in the office full time and we are continuing have the front office opened to the public Monday through Friday. Over 50% of all staff are now vaccinated.

*May 26, 2021 update:* According to voluntary data, approximately 70% of West Bay staff have been vaccinated. Staff continues to follow Health Department guidelines.

*June 9, 2021 update:* Staff is following the County and State updates closely as restrictions ease up.

### **Fiscal Impact**

While there has been considerable expense to implementing some of the COVID 19 mitigation measures such as; converting the FERRF office space (approx. \$2,000), purchasing PPE for stock (\$8,000 to \$10,000), Public Outreach (\$10,500), Zoom Meeting Equipment (approx. \$6,000) these expenses were absorbed in the Operating budget. The FY2020-21 Budget could be substantially impacted by the effects of the national COVID 19 response. To date approximately \$5300.00 has been spent in PPE, \$2000.00 in disinfecting equipment, and \$1927.00 in producing and updating the COVID 19 Response Plan.

### **Recommendation**

The District Manager recommends the Board accept this report and provide comments to the District Manager in regards to the report. Additional information may be available at the Board meeting as conditions and responses are rapidly changing throughout the COVID-19 pandemic.

THIS PAGE LEFT INTENTIONALLY BLANK



**WEST BAY SANITARY DISTRICT  
AGENDA ITEM 13**

**To: Board of Directors**

**From: Sergio Ramirez, District Manager**

**Subject: Report and Discussion on the West Bay and Sharon Heights  
Recycled Water Facility**

---

A discussion will be held on the Sharon Heights Recycled Water Facility and other events related to the recycled water plant. The Board will have opportunity to provide direction to staff and legal counsel.

The following is a disclosure statement required for any document, written report or brochure prepared in whole or in part pursuant to the Finance Agreement with the State Water Resources Control Board for the West Bay Sanitary District Recycled Water Project - Sharon Heights:

*Funding for this project has been provided in full or in part through an agreement with the State Water Resources Control Board. California's Clean Water State Revolving Fund is capitalized through a variety of funding sources, including grants from the United States Environmental Protection Agency and state bond proceeds. The contents of this document do not necessarily reflect the views and policies of the foregoing, nor does mention of trade names or commercial products constitute endorsement or recommendation for use.*

THIS PAGE LEFT INTENTIONALLY BLANK





**WEST BAY SANITARY DISTRICT  
AGENDA ITEM 14**

**To: Board of Directors**

**From: Sergio Ramirez, District Manager**

**Subject: Discussion and Direction on the Bayfront Recycled Water Project  
and Status Update**

---

A discussion will be held on the District's Bayfront Recycled Water Projects and other events related to the recycled water projects including financing, environmental review, design/build issues and grant applications.

The Board will have opportunity to provide direction to staff and legal counsel.

THIS PAGE LEFT INTENTIONALLY BLANK



**WEST BAY SANITARY DISTRICT  
AGENDA ITEM 15**

**To: Board of Directors**

**From: Sergio Ramirez, District Manager**

**Subject: Report and Discussion on South Bayside Waste Management Authority (SBWMA)**

---

The District's representative to South Bayside Waste Management Authority (SBWMA), President Fran Dehn, will report on any pertinent items regarding SBWMA business.

THIS PAGE LEFT INTENTIONALLY BLANK



**WEST BAY SANITARY DISTRICT  
AGENDA ITEM 16**

**To: Board of Directors**

**From: Sergio Ramirez, District Manager**

**Subject: Report and Discussion on Silicon Valley Clean Water (SVCW)  
Plant**

---

The District's representative to Silicon Valley Clean Water (SVCW), Commissioner George Otte, will report on pertinent items regarding SVCW Operations, CIP and Finance.

---

**Report to the District Board for the Regular Meeting of June 9, 2021**

THIS PAGE LEFT INTENTIONALLY BLANK



**WEST BAY SANITARY DISTRICT  
AGENDA ITEM 18**

**To: Board of Directors**

**From: Sergio Ramirez, District Manager  
Debra Fisher, Finance Manager**

**Subject: Consideration to Adopt Resolution Establishing Rates of Pay  
and Related Compensation Provisions**

---

**Background**

On June 26, 2019, the Board adopted a Memorandum of Understanding (MOU) between the District and Teamsters Local 350. The provisions in the MOU include approved pay increases, effective June 1, 2019. Increases are determined for the five-year term of the MOU. The 4% increase per year is effective on June 1, 2019 and is based on the approved MOU.

On March 25, 2020 the Board approved the Resolution Establishing the Rates of Pay to include the adjusted salary ranges for the Water Quality Manager and the Water Quality Supervisor/Chief Plant Operator. Subsequently, the Board approved the current Rates of Pay schedule on June 24, 2020.

During the Budget Workshop on May 5, 2021 staff proposed hiring a Utility Worker/ Operator in Training to provide support for the Chief Plant Operator and the Pump Station crew. It was reported the new position would be funded by the STEP/Grinder fees and recycled water projects. The position would be filled only if approved by the Board during the budget process.

On June 3, 2021 the newly formed IT Committee met with District Staff to discuss the IT Department and the IT Analyst's duties and responsibilities. Direction was given to District Staff on how to proceed with the proposed rates of pay.

**Analysis**

The attached Resolution is required to adjust the individual salary ranges by 4% and related compensation provisions for represented, unrepresented, and management employees, including the new salary ranges as approved by the Board of Directors.

### Fiscal Impact

Salaries and employee benefits will increase per the terms of the MOU and as approved by the Board of Directors. Employees will continue to contribute to the employer's PERS portion at a rate of .25% per year beginning July 1, 2019. Effective July 1, 2020, 0.5%; effective July 1, 2021, 0.75%; effective July 1, 2022, 1.00%; and effective July 1, 2023 1.25%. Additionally, the employee shall pay to PERS the employee's portion of the total required contribution (i.e. 8% of pay for Classic Tier I, 7% Classic Tier II, and 6.75% of pay for PEPRA staff). To-date thirteen employees are in Tier I, one employee is in Tier II, and seventeen employees are in PEPRA.

### Recommendation

The District Manager recommends adoption of the attached Resolution.



**RESOLUTION NO. \_\_\_\_ (2021)**

**RESOLUTION ESTABLISHING RATES OF PAY AND RELATED COMPENSATION  
PROVISIONS FOR CERTAIN EMPLOYEES OF THE WEST BAY SANITARY DISTRICT**

\*\*\*

*BE IT RESOLVED BY THE DISTRICT BOARD OF THE WEST BAY SANITARY DISTRICT,  
COUNTY OF SAN MATEO, STATE OF CALIFORNIA, AS FOLLOWS:*

1. Executive Employees (FLSA exempt). The following monthly salary rates in dollars are hereby established for each of the employee positions within the executive employee category as hereinafter set forth, and the individuals duly appointed to said positions of employment shall be compensated at such rates for all services rendered to this District.

<b>Position</b>	<b>Salary Rate</b>
District Manager	16,727 - 20,072

2. Management Employees (FLSA exempt). The following monthly salary rates in dollars are hereby established for each of the employee positions within the management employee category as hereinafter set forth, and the individuals duly appointed to said positions of employment shall be compensated at such rates for all services rendered to this District.

<b>Position</b>	<b>Salary Rate</b>
Projects & IT Manager	11,193 - 15,669
Operations Superintendent	10,427 - 15,119
Water Quality Manager	10,114 - 15,119
Finance Manager	11,193 - 15,669
Office & Communications Manager	6,918 - 10,032

3. General Employees (unrepresented). The following monthly salary rates in dollars are hereby established for each of the listed employee positions within the general employee (unrepresented) category as hereinafter set forth, and the individuals duly appointed to said positions of employment shall be compensated within such rates for all services rendered to this District.

<b>Position</b>	<b>Salary Rate</b>
Assistant Operations Superintendent	9,036 - 12,199
Water Quality Supervisor/Operator	9,036 - 12,199
Pump Facility Supervisor	9,106 - 11,781
Operations Supervisor	9,106 - 11,781
Information Technology Analyst	6,722 - 11,350
Engineering Technician	7,940 - 11,063
Personnel & Accounting Specialist	6,974 - 9,102
Administrative Technician	5,673 - 7,942
Part-Time Clerical Assistant	21 - 26/hour

4. General Employees (represented). The following monthly salary rates in dollars are hereby established for each of the listed employee positions within the general employee (represented) category as hereinafter set forth, and the individuals duly appointed to said positions of employment shall be compensated within such rates for all services rendered to this District.

<b>Position</b>	<b>Salary Rate</b>
Construction Inspector	7,938 - 11,065
Source Control Inspector	7,938 - 11,065
Field Supervisor	6,614 - 10,086
Rehabilitation Technician	6,073 - 9,016
Pipeline Inspection Technician	6,073 - 9,016
Maintenance Mechanic	6,073 - 9,016
Utility Worker / Operator in Training	6,073 - 9,016
Maintenance Worker	5,515 - 7,942
Temporary Maintenance Worker	27/hour

5. Health Benefits Plan.

(a) Subject to all terms and conditions of any agreement which may be entered into between this District and any organization or organizations offering health, dental and/or vision insurance and the provisions of the Public Employees' Medical and Hospital Care Act, the District shall contribute for each employee enrolled the amount necessary to pay for the full cost of his or her enrollment, including the enrollment of his or her family members in a health benefits plan up to the amount required pursuant to Section 22892 of the Government Code.

(b) Subject to all terms and conditions of any agreement which may be entered into between this District and any organization or organizations offering health, dental and/or vision insurance and the provisions of the Public Employees' Medical and Hospital Care Act, the District shall contribute for each annuitant the amount required pursuant to Section 22892 of the Government Code.

(c) The District may, at its sole discretion, enter into, amend, or cancel any agreement between this District and any organization or organizations offering health, dental and/or vision insurance.

6. Optional Benefits Package ("Cafeteria Plan"). Subject to all terms and conditions of any agreement which may be entered into at the employees' option between employees and any organization offering either health, dental, vision and/or universal life insurance benefits, the District shall pay to all represented and unrepresented employees the amount specified in the adopted Memorandum of Understanding Between the West Bay Sanitary District and Teamsters Local 350 adopted by the Board of Directors for the premium of such optional benefits attributable to management, represented, and unrepresented employees of the District.

7. Life Insurance. Subject to all terms and conditions of any agreement which may be entered into between this District and any organization or organizations offering life insurance coverage benefits, the District shall furnish to each employee general life

insurance coverage, the face amount of which shall be equal to one and a half (1.5) times the annual salary of the employee.

8. Deferred Compensation. The District will provide matching contributions for unrepresented employees at a one (1) to 0.75 ratio to a maximum of 3% of salary. I.E. If an employee contributes 4% of their salary to a 457 Deferred Compensation plan the District will contribute 3% of salary equivalent to the employee's 457 Deferred Compensation plan.

9. Retention Plan. In order to promote the retention of "Critical Positions" within the District, the District Manager is authorized to exceed the salary ranges for individuals within this category up to 1-1/2% of base salaries for the positions deemed critical to be distributed at the District Manager's discretion based on achievement of performance goals established for the individuals within the category. Positions deemed critical are determined by recommendation of the District Manager and approved by the District Board.

10. Retirement Plan. Subject to the provisions of this Resolution, retirement benefits for employees qualifying therefore shall be provided in accordance with, and pursuant to that certain contract between the Board of Administration of the Public Employees' Retirement System ("PERS") of the State of California and the District Board of this District, and amendments thereto approved by Resolution No. 628, adopted March 26, 1973 and subsequent Resolutions.

Subject to other provisions of the contract and Resolutions referred to above, the District shall pay to PERS the employer portion. Employees will contribute to the employer's PERS portion at a rate of .25% per year affective July 1, 2019. Effective July 1, 2020, 0.5%; effective July 1, 2021, 0.75%; effective July 1, 2022, 1.00%; and effective July 1, 2023 1.25%. Additionally, the employee shall pay to PERS the employee's portion of the total required contribution (i.e. 8% of pay for Classic Tier I, 7% for Classic Tier II, and 6.75% for PEPRAs members).

11. Interpretation. The provisions of the Resolution shall be administered and interpreted in accordance with and pursuant to Resolution No. 759 of this District, adopted June 13, 1977 (and as amended). Nothing herein shall be deemed a limitation upon any other term and condition of employment, or agreements, or provisions relating thereto, except as specifically herein contained.

12. Effective Date. This Resolution shall be effective on July 1, 2021.

BE IT FURTHER RESOLVED that any and all previously adopted Resolutions or provisions thereof in conflict with the provisions herein contained, be and are hereby, rescinded.

\*\*\*\*\*

Passed and adopted by the District Board of the West Bay Sanitary District at a regular meeting thereof held on the 9<sup>th</sup> day of June, 2021 by the following vote:

AYES:

NOES:

ABSTAIN:

ABSENT:

\_\_\_\_\_  
President of the District Board of the  
West Bay Sanitary District of San Mateo  
County, State of California

Attest:

\_\_\_\_\_  
Secretary of the District Board of the  
West Bay Sanitary District of San Mateo  
County, State of California