

*1902 - Serving Our Community for over 115 Years - 2020*

**WEST BAY SANITARY DISTRICT  
AGENDA OF BUSINESS  
REGULAR MEETING OF THE DISTRICT BOARD  
WEDNESDAY, AUGUST 12, 2020 AT 7:00 P.M.  
RONALD W. SHEPHERD ADMINISTRATION BUILDING,  
500 LAUREL STREET, MENLO PARK, CALIFORNIA 94025**

**Board Members**

Fran Dehn, President  
David Walker, Secretary  
Roy Thiele-Sardiña, Treasurer  
Edward P. Moritz, Member  
George Otte, Member

**District Manager**

Sergio Ramirez

**District Legal Counsel**

Anthony Condotti, Esq.

**AGENDA OF BUSINESS**

**NOTICE OF PUBLIC PARTICIPATION BY TELECONFERENCE ONLY**

Pursuant to Governor Newsom's Executive Order N-29-20, members of the West Bay Sanitary District Board of Directors and Staff may participate in this meeting via a teleconference. In the interest of reducing the spread of COVID- 19, members of the public are allowed to participate telephonically only, and may submit comments in advance by email addressed to [treese@westbaysanitary.org](mailto:treese@westbaysanitary.org) by 4:00 p.m. on Wednesday, August 12<sup>th</sup>.

To participate by telephone or Zoom meeting, public comments can be made by joining Zoom meeting at: <https://zoom.us/j/95021408549?pwd=cHFRVisrWEdHOHM1OWFCN0x4d2liUT09>

Meeting ID: 950 2140 8549 Passcode: 885652

Or by phone, call: 1-669-900-6833 Meeting ID: 950 2140 8549 Passcode: 885652

Following receipt of public comment and open session items, the Board will adjourn to closed session. Reportable action, if any, will be available upon inquiry within twenty-four (24) hours.

***NOTE: The Board may take action on any agendized item unless specifically designated a "discussion" item or a "report."***

1. Call to Order and Roll Call
2. Communications from the Public
3. Consideration to Approve the Final Acceptance (Notice of Completion) for the Construction of the Recycled Water Project – Sharon Heights and Authorize the District Manager to Issue a Final Acceptance Letter and Commence the Short Term Operations by Anderson Pacific Engineering Construction per the Design Build and Short Term Operations Agreement Pg. 3-1
4. Consider to Authorize the District Manager to Remit to Anderson Pacific Engineering Construction Inc., Fifty Percent of Retention for the Construction of the Recycled Water Project – Sharon Heights Prior to the End of the 60 Day Waiting Period Pg. 4-1
5. Consent Calendar

*Matters listed under this item are considered routine and will be enacted by one motion. The motion, seconds, and vote are applicable to any included resolutions and recorded accordingly. There will be no separate discussion of these items unless specifically requested by a member of the Board.*

  - A. Approval of Minutes for Regular meeting July 8, 2020 Pg. 5A-1
  - B. Approval of the Withdrawal Order Authorizing Payment of Certain Bills and Salaries and Consideration of Other Financial Matters for August 12, 2020 Pg. 5B-1
  - C. WBSD Operations and Maintenance Report – July 2020 Pg. 5C-1
  - D. Town of Los Altos Hills Operations and Maintenance Report for Work Performed by WBSD – July 2020 Pg. 5D-1

- E. Consideration to Approve District's Investment Portfolio Reports Including the Transactions of Assets Described Therein as of 6/30/20 Pg. 5E-1
  - F. Consideration to Authorize the District Manager to Issue the Class 3 Permit for the Sewer Main Installation on San Antonio Street, Menlo Park, CA Pg. 5F-1
  - G. Consideration to Approve Amendment to the District's Excavation, Backfill, and Surface Restoration Detail No. 8 Pg. 5G-1
6. District Manager's Report Pg. 6-1
  7. Consideration to Approve Resolution for the Audited & Revised Sewer System Management Plan (SSMP) and Authorizing Re-Certification for 2020 Pg. 7-1
  8. Consideration to Approve Purchase of a 2020 Ford Ranger for Water Quality Supervisor Pg. 8-1
  9. Consideration to Approve the Purchase of a 2020 Ford Super Duty F-350 Pump Supervisor Truck with Crane Pg. 9-1
  10. Consideration to Approve Amendment 3 to the Consultant Agreement for Recycled Water Project Management Phase B Dated March 14, 2017 Pg. 10-1
  11. Review and Consideration to Approve the Conflict of Interest Code and General Rules of Office for the District Board Pg. 11-1
  12. August 12<sup>th</sup> Update Report on District Response to Corona Virus Pg. 12-1
  13. Consideration to Authorize the District Manager to Enter Into a Fleet Equipment Maintenance Agreement with the City of Redwood City Pg. 13-1
  14. Discussion and Direction on Recycled Water Projects - Sharon Heights & Bayfront, Including Project Status Pg. 14-1
  15. Report & Discussion on South Bayside Waste Management Authority (SBWMA) Pg. 15-1
  16. Report & Discussion on Silicon Valley Clean Water (SVCW), Discussion on SVCW CIP Program and Financing Pg. 16-1
  17. Closed Session:
    - A. CONFERENCE WITH LABOR NEGOTIATORS  
(Pursuant to Cal. Govt. Code §54957.6) Agency designated representatives: Board President/Legal Counsel  
Unrepresented Employee: Finance Manager
    - B. PUBLIC EMPLOYEE PERFORMANCE EVALUATION:  
Title: District Manager
    - C. CONFERENCE WITH LEGAL COUNSEL – ANTICIPATED LITIGATION  
Significant exposure to litigation pursuant to Cal. Govt. Code § 54956.9(d)(2):  
(1 potential case)
  18. Comments or Reports from Members of the District Board and Consider Items to be Placed on Future Agenda
  19. Adjournment

The West Bay Sanitary District does not discriminate against persons with disabilities. Upon request, the agenda and agenda packet can be provided in a format to accommodate special needs. If you require a copy of the agenda or related materials in an alternative format to accommodate a disability, or if you wish to attend this public meeting and will require special assistance or other special equipment, please call the District at (650) 321-0384 at least five days in advance and we will make every reasonable attempt to provide such an accommodation.



## WEST BAY SANITARY DISTRICT AGENDA ITEM 3

**To:** *Board of Directors*

**From:** *Sergio Ramirez, District Manager*

**Subject:** *Consideration to Approve the Final Acceptance (Notice of Completion) for the Construction of the Recycled Water Project– Sharon Heights and Authorize the District Manager to Issue a Final Acceptance Letter and Commence the Short Term Operations by Anderson Pacific Engineering Construction per the Design Build and Short Term Operations Agreement*

---

### Background

The West Bay Sanitary District Recycled Water Project – Sharon Heights (also known as the “Project”) is the planned construction of a water supply project that would deliver up to 152 to 200 acre-feet per year (AFY) of recycled water produced by the District at a Recycled Water Treatment Plant (RWTP) located on property owned by Sharon Heights Golf and Country Club (SHGCC).

The District Board approved a Notice to Proceed on the Recycled Water Project – Sharon Heights Design Build and Short Term Operations on March 1, 2018, for a not-to-exceed amount of \$19,695,000.00 for Design, Construction and Operational Testing and \$325,000.00 for Short Term Operations to Anderson Pacific Engineering Construction Inc., (APEC).

West Bay Sanitary District received a letter dated May 7, 2020 from Matthew Mirenda on behalf of Anderson Pacific Engineering Construction (APEC), regarding the “WBSD Recycled Water Project - Sharon Heights Final Acceptance”. The letter listed the Closeout Submittals and provided a status on those submittals. At that time the Board declined to issue a Final Acceptance of the project due to a failed bioassay test of the UV system and hence the lack of a Notice of Applicability (aka Permit to Operate) from the Regional Water Quality Control Board.

APEC, has now submitted a second final acceptance request dated July 28 (See Attached) citing the following to have been completed:

1. Notice of Applicability (*aka Title 22 Permit*) issued by the Regional Water Quality Control Board on July 24, 2020.
-

2. 15 Day Notice of Operation *issued by West Bay Sanitary District on July 27, 2020 (submitted to the Regional Board - See Attached).*
3. Spot-Check Bioassay (SCB) Report, *dated July 2020, summarizing the successful SCB re-test validating both Trojan UVFit™ reactors at 100% of the 2012 NWRI Guidelines.*

The Project's Request for Proposal states the District has 21 days from receiving the letter from APEC requesting Final Acceptance to formally accept the project or delineate what is not acceptable.

Now that the construction of the RWTP is complete, staff is requesting the Board authorize the District Manager to issue the Final Acceptance Letter (Attached).

### Analysis

The RWTP project is complete and operating successfully. The only outstanding issue is the final painting of the cabinet to the Phil Scott Pump Station at Sandhill Road and Oak Ave. which requires a sign offs from the City permit. The remaining issue will be taken care of by District in-house staff on or about September 1, 2020.

As of July 27, 2020 the RWTP is producing and delivering Title 22 quality recycled water to the golf course.

The significance of the Final Acceptance is that it starts the 60-day clock for the District to release the retention held on the project. Staff is recommending the Board approve the Final Acceptance of the project and ratify the six (6) month Short Term Operation commencement effective July 27, 2020. Thus the 6-month Short Term Operation period is anticipated to take place from July 27, 2020 to January 27, 2021.

During the Short Term Operation period the District's Water Quality Supervisor, who will be the Chief Plant Operator for the treatment facility once the District takes control of Operation and Maintenance, will be allowed to shadow APEC's contract Operator to learn the operational characteristics, parameters and idiosyncrasies of the RWTP. The intent is to have the District's Water Quality Supervisor learn and assist the Contract Operator with sampling, monitoring, process control, data acquisition, regulatory requirements, reporting, maintenance, and safety procedures so the transition from APEC to the District operating the RWTP will be a smooth and seamless one.

### Fiscal Impact

Per the Long-Term Agreement with Sharon Heights Golf & Country Club (SHGCC), the costs for the 6-month Operation period by APEC are reimbursable by SHGCC. The District will invoice SHGCC monthly. District Capital Asset funds will bridge the expense until reimbursement is received by the SHGCC.



## Recommendation

The District Manager recommends the District Board Approve the Final Acceptance (Notice of Completion) for the Construction of the Recycled Water Project – Sharon Heights and Authorize the District Manager to Issue a Final Acceptance Letter and Commence the Short Term Operations by Anderson Pacific Engineering Construction per the Design Build and Short Term Operations Agreement.

### Attachment:

APEC Letter dated July 28, 2020

State Water Board NOA and MRP (On-File)

WBSD 15 Day Notice of Operation Letter dated July 27, 2020

Draft Final Acceptance Letter to APEC

Final Punch List August 6, 2020



July 28, 2020

West Bay Sanitary District  
WBSD Recycled Water Project  
701 Laurel St.  
Menlo Park, CA 94025

Attn: Sergio Ramirez  
Re: WBSD Recycled Water Project -Sharon Heights  
Final Acceptance

Dear Mr. Ramirez

Pursuant Section 8.6 of the Project Element Narratives, Anderson Pacific Engineering Construction, Inc. again calls for Final Acceptance of the “*Recycled Water Project -Sharon Heights*” project. As part of the Final Document Submittal, we are adding the following files.

1. *Notice of Applicability* (aka Title 22 Permit) issued by the Regional Water Quality Control Board on July 24, 2020.
2. *Notice of Operation* issued by West Bay Sanitary District on July 27, 2020.
3. *Spot-Check Bioassay Report*, dated July 2020, summarizing the successful SCB re-test validating both Trojan UVFit™ reactors at 100% of the 2012 NWRI Guidelines.

Copies of these documents have been uploaded to the “*Closeout Documents*” folder on SharePoint and are sent as attachments to the email transmitting this letter.

Sincerely,

Matthew Miranda  
Project Manager

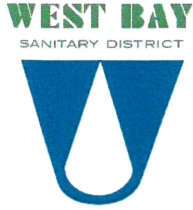

*Serving Our Community Since 1902*

500 Laurel Street, Menlo Park, California 94025-3486 (650) 321-0384 (650)321-4265 FAX

SERGIO RAMIREZ  
District Manager

In reply, please refer to our  
File No.

Agreement No.: D16-01018  
Project No.: C-06-8163-110  
1760.0

**July 27, 2020**

**Melissa Gunter**

Water Resources Control Engineer  
SF Bay Regional Water Quality Control Board  
1515 Clay Street, Suite 1400  
Oakland, CA 94612  
510.622.2390 | office  
*Sent electronically to: [Melissa.Gunter@waterboards.ca.gov](mailto:Melissa.Gunter@waterboards.ca.gov)*

**Subject: Notice of Operation of West Bay Sanitary District's Recycled Water Facility – Sharon Heights, CIWQS Place ID 864895 and DDW System No. 4190008**

Dear Ms. Gunter,

Pursuant to the Notice of Applicability (NOA) dated July 24, 2020 and Water Quality Order WQ 2016-0068-DDW, the West Bay Sanitary District is hereby submitting Notice to the Regional Water Board of commencement of the operation of the treatment system resulting in recycled water uses as of July 27, 2020, thereby meeting the 15-day notification requirement.

The treatment system is and will continue to operate conforming to the conditions set forth in the NOA and the Monitoring and Reporting Program.

Feel free to call me at (650) 321-0384 with any questions.

Very truly yours,

**WEST BAY SANITARY DISTRICT**

Sergio Ramirez  
District Manager

cc: BHK, JMB, QMG, PLS, Tony Condotti- District Counsel, File, Woodard & Curran, and APEC



*Serving Our Community Since 1902*

500 Laurel Street, Menlo Park, California 94025-3486 (650) 321-0384 (650)321-4265 FAX

SERGIO RAMIREZ  
District Manager

In reply, please refer to our  
File No.

August 13, 2020

Peter Anderson  
Anderson Pacific Engineering Construction, Inc.  
1390 Norman Avenue  
Santa Clara, CA 95054

RE: FINAL ACCEPTANCE RECYCLED WATER PROJECT - SHARON HEIGHTS DESIGN BUILD AND SHORT-TERM OPERATIONS Project #1760.0 (Design-Build Agreement)

Dear Mr. Anderson,

West Bay Sanitary District has received your letter dated July 28, 2020 from Matthew Miranda on behalf of Anderson Pacific Engineering Construction (APEC), regarding the "WBSD Recycled Water Project - Sharon Heights Final Acceptance". The letter listed the Closeout Submittals and provided a status on those submittals.

The District Board approved a Notice to Proceed on the Recycled Water Project – Sharon Height Design Build and Short Term Operations on March 1, 2018, and has now approved Final Acceptance (Notice of Completion) at the August 12, 2020 Board meeting, effective July 27, 2020.

The RWTP project is complete and operating successfully. The only outstanding issue is the final painting of the cabinet to the Phil Scott Pump Station at Sandhill Road and Oak Ave. which requires a sign offs from the City permit. The remaining issue will be taken care of by District in-house staff on or about September 1, 2020.

As of July 27, 2020 the Operation of the RWTP has commenced and the delivery of recycled water to the SHGCC is taking place. Thus the 6-month Short Term Operation period will take place from July 27, 2020 to January 27, 2021.

As the parties have mutually agreed, upon commencement of the Short Term Operation period the District's Water Quality Supervisor, who will be the Chief Plant Operator for the treatment facility once the District takes control of Operation and Maintenance, has begun to shadow APEC's contract Operator to learn the operational characteristics, parameters and idiosyncrasies of the Recycled Water Treatment Plant (RWTP).

Name  
August 7, 2020  
Page | 2

On or about January 27, 2020, the District's Water Quality Supervisor will replace the Contract Operator as the Chief Plant Operator (CPO) and perform the CPO duties and the District will take over all Operations and Maintenance of the RWTP.

We'd like to thank you for your services, contributions, and dedication to this substantial construction project.

Very Truly Yours,

WEST BAY SANITARY DISTRICT

Sergio Ramirez  
District Manager

cc: Anthony Condotti, BHK, Greg Vontz, SWRCB, Sami Kader, Woodard & Curran

Enclosure(s): Punch List.

# WBSD RWF - Sharon Heights

## PUNCH LISTS

Dated 3/25 and 3/30/2020

Updated 4/24/2020

**ORIGINAL**

| <u>No.</u> | <u>ITEM</u>  | <u>STATUS</u>  | <u>DATE COMPLETED</u> | <u>WBSD SIGNOFF</u>               |
|------------|--|--|-----------------------|-----------------------------------|
| 1          | All labels to be affixed in proper placement including near outside chemical enclosure and in the Mechanical Room.                       |  | 4/6/2020              | <i>JB</i> 4/27                    |
| 2          | All permits for operating the plant must be obtained and in effect.  | Verbal approval; waiting for T22 Permit to be approved | 3/16/2020             | JB - 8/6/20                       |
| 3          | Verification that the lowest fixture or floor drain is 12 inches or more higher in elevation than the rim elevation of District manhole. |  | 4/17/2020             | <i>JB</i> 4/27                    |
| 4          | Ph probe installed   |  | 4/6/2020              | <i>JB</i> 4/27                    |
| 5          | Washer and hold down escutcheon installed on outside eye wash station  |  | 4/17/2020             | <i>JB</i> 4/27                    |
| 6          | Fill Station water meters installed and operational  |  | 4/13/2020             | <i>JB</i> 4/27                    |
| 7          | Photo confirmation of exterior night lighting is working and in proper condition   |  | 4/15/2020             | <i>JB</i> 4/27                    |
| 8          | Signage at Fill Station is installed compliant with Title 22   |  | 4/13/2020             | <i>JB</i> 4/27                    |
| 9          | All Fill Station hydrants and Fill Station ports and painted purple  |  | 4/14/2020             | <i>JB</i> 4/27                    |
| 10         | Asphalt berms are installed at treatment facility turnaround and Fill Station turnout.   |  | 4/4/2020              | <i>JB</i> 4/27                    |
| 11         | Receipt of spare drum screen is verified.  | Part of CCO #5<br>Revised shipping date 5/29/2020      |                       | JB - 8/6/20                       |
| 12         | All SCADA programming complete including IPS time of bypass.   |  | 4/7/2020              | <i>JB</i> 4/27                    |
| 13         | Internet Cable is installed and operational for all computer and communication needs.  |  | 4/15/2020             | <i>JB</i> 4/27                    |
| 14         | Caltrans encroachment permit signed off.   | Final Inspection Sch'd 5-8-20                          | 7/30/2020             | Confirmed by Jonathan<br>8-5-2020 |



| <u>No.</u> | <u>ITEM</u>  | <u>STATUS</u>   | <u>DATE COMPLETED</u> | <u>WBSD SIGNOFF</u>               |
|------------|--|---|-----------------------|-----------------------------------|
| 15         | Menlo Park encroachment permit signed off.   | Requested signoff. Unable to work in City Park to replace trees during shutdown |                       |                                   |
| 16         | Submittal of data verifying compliance of Air quality and odor standards during 30-day Demonstration period. |   | 4/27/2020             | JB 4/27<br>collecting data weekly |
| 17         | Submittal of all warranty and guarantee documents for equipment and processes.                               | Submitted w/ Final Acceptance package   | 5/1/2020              | JB - 8/6/20                       |
|            | NOT USED   |   | -                     | -                                 |
|            | <u>PIPELINE</u>  |   | -                     | -                                 |
| 20         | As-Built drawings  | Uploaded to SharePoint  | 5/1/2020              | Confirmed by Jonathan<br>5-7-2020 |
| 21         | Sign off from City of Menlo Park   | see #15 above Panel needs to get painted green                                  |                       |                                   |
| 22         | Sign off from San Mateo County   | Permit # <u>DPW2018-01291</u>   | 6/25/2019             | Confirmed<br>4-30-2020            |
| 23         | Manhole #H12084 Remove 36" ACP inside MH   |   | 5/1/2020              | Confirmed by Jonathan<br>8-5-2020 |
| 24         | Manhole #H12078 Install Weir   | Tested flow with PS on & PS off<br>5/5/2020                                     | 5/4/2020              | Confirmed by Jonathan<br>5-7-2020 |
| 25         | Manhole #H12078 pick hole is filled with AC  |   | 5-1-2020              | Confirmed by George<br>5-6-2020   |
| 26         | Remove Tree Protection Near Pump Station   |   | 4/16/2020             | Confirmed<br>4-30-2020            |
| 27         | Remove Construction Fence around cul-de-sac  | Snow Fence left to protect landscaping  | N/A                   | Confirmed by George<br>5-6-2020   |
| 28         | Fiber roll (BMP) left in SD Channel  | Fiber Roll Installed by Hewitt Foundation. Not related to our Project           | N/A                   | Confirmed<br>4-30-2020            |
| 29         | Near STA 28+00 Cal Water Meter box broken  |   | 5/4/2020              | Confirmed by George<br>5-6-2020   |
| 30         | Near STA 31+50 Stanford Bus Stop Sign needs to be replaced.  | Pole replaced, Stanford to update schedule/sign                                 | 5-1-2020              | Confirmed by George<br>4-30-2020  |
| 31         | Near STA 38+25 ARV Trace Wire missing  |   | 4/15/2020             | Confirmed<br>4-30-2020            |



| <u>No.</u> | <u>ITEM</u>   | <u>STATUS</u>                                 | <u>DATE COMPLETED</u> | <u>WBSD SIGNOFF</u>                       |
|------------|---|---|-----------------------|---|
| 32         | Near STA 41+00 SD catch basin needs to be raised to grade         |   | 4/14/2020             | <i>Confirmed<br/>4-30-2020</i>            |
| 33         | Near STA 52+50 ARV Trace Wire missing                             |   | 4/15/2020             | <i>Confirmed<br/>4-30-2020</i>            |
| 34         | Near STA 68+00 ARV missing  | Rim Elevation need adjusting. WE<br>4.24.2020 | 5-6-2020              | <i>Confirmed by George<br/>5-6-2020</i>   |
| 35         | Near STA 77+50 ARV Trace Wire missing                             |   | 4/15/2020             | <i>Confirmed<br/>4-30-2020</i>            |
| 36         | Near STA 77+50 ARV (gate valve shall be replaced with ball valve) |   | 5-1-2020              | <i>Confirmed by George<br/>5-6-2020</i>   |
| 37         | NOT USED  |   | ---                   |   |
| 38         | Near STA 78+75 PG&E box broken                                    |   | 5-1-2020              | <i>Confirmed by George<br/>5-6-2020</i>   |
| 39         | Near STA 86+00 ARV Is Leaking                                     |   | 5-1-2020              | <i>Confirmed by<br/>Jonathan</i>          |
| 40         | Near STA 86+00 ARV Tracer Wire missing                            |   | 4/16/2020             | <i>Confirmed<br/>4-30-2020</i>            |
| 41         | Near STA 86+00 backfill and clean up                              |   | 4/9/2020              | <i>Confirmed<br/>4-30-2020</i>            |
| 42         | Fill Station# 2 in Center Island Sta 95+15                        |   | 4/14/2020             | <i>Confirmed<br/>4-30-2020</i>            |
| 43         | Tracer Wire Pull Box For casing pipe.                             |   | 4/16/2020             | <i>Confirmed<br/>4-30-2020</i>            |
| 44         | Hydroseed Center Island   |   | 4/15/2020             | <i>Confirmed<br/>4-30-2020</i>            |
| 45         | Hydroseed Stanford property North Side                            | Alignment hand-seeded.                        | 5-5-2020              | <i>Confirmed by Jonathan<br/>8-5-2020</i> |
| 46         | Fill Station# 1 STA 160+00  |   | 4/14/2020             | <i>Confirmed<br/>4-30-2020</i>            |
| 47         | ARV Near Recycled Water Plant                                     |   | 4/13/2020             | <i>Confirmed<br/>4-30-2020</i>            |
| 48         | --END--   |   | ---                   |   |



## WEST BAY SANITARY DISTRICT AGENDA ITEM 4

**To:** *Board of Directors*

**From:** *Sergio Ramirez, District Manager*

**Subject:** *Consideration to Authorize the District Manager to Remit to Anderson Pacific Engineering Construction Inc., Fifty Percent of Retention for the Construction of the Recycled Water Project – Sharon Heights Prior to the End of the 60 Day Waiting Period*

---

### Background

Per the Design/Build agreement with Anderson Pacific Engineering Construction Inc., (APEC), the District is holding as retention pay for the project, approximately \$517,507.75 equal to 2.5% of the Project price plus contingency.

The original retention amount was 5% but the Board previously authorized a reduction to 2.5% in light of the exemplary work being done and that most of the work was being performed directly by APEC resulting in relatively few subcontractors.

Retention pay is traditionally held on projects 60 days after completion of the project primarily to protect against claims from subcontractors of non-payment by the General Contractor for goods or services.

### Analysis

APEC has relatively few subcontractors and the Projects & IT Manager is satisfied releases have been obtained from the subcontractors, significantly reducing any risk of a claim for non-payment.

Additionally, the Design/Build contractor, APEC, has worked the last 2-1/2 months without any remuneration while waiting for the bioassay testing on the UV system to be completed and allow us to deliver recycled water to the golf course. This process was completed on July 24, 2020.

### Fiscal Impact

There is no fiscal impact as the money is owed and will be paid 60 days from the Final Acceptance. Whether the District pays 50% of the remaining retention now or later has no impact to the budget.

---

### Recommendation

The District Manager recommends the District Board authorize the District Manager to remit 50% (\$258,753.88) of the remaining retention held on the project to APEC prior to the 60 day waiting period and remit the remaining 50% of the retention when the waiting period is completed on or about September 27<sup>th</sup>, 2020.



*1902 - Serving Our Community for over 110 Years - 2020*

**WEST BAY SANITARY DISTRICT  
MINUTES OF THE REGULAR MEETING OF THE DISTRICT BOARD  
WEDNESDAY, JULY 8, 2020 AT 7:00 P.M.**

**1. Call to Order**

President Dehn called the meeting to order at 7:02 PM

**Roll Call**

BOARD MEMBERS PRESENT: President Dehn, Secretary Walker, Treasurer Thiele-Sardiña, , Director Otte

BOARD MEMBERS ABSENT: Director Moritz

STAFF MEMBERS PRESENT: District Manager Sergio Ramirez; District Counsel Tony Condotti via Zoom; Water Quality Manager Jed Beyer.

Others Present: Former District Manager Phil Scott via Zoom.

**2. Communications from the Public: None.**

**3. Public Hearing: Consideration to Approve Resolution Confirming Report on Sewer Service Charges for West Bay Sanitary District for the Fiscal Year 2020/2021**

Motion to Open Public Hearing by: Thiele-Sardiña 2<sup>nd</sup> by: Walker Vote: AYE: 4 NAY: 0 Abstain: 0

Comments: Treasurer Thiele-Sardiña asked to review the large commercial customer's water usage data for the 2017, 2018, and 2019 years. Former District Manager Scott suggested looking at the last three years' worth of rate study reports to gather the data.

Motion to Close Public Hearing by: Walker 2<sup>nd</sup> by: Otte Vote: AYE: 4 NAY: 0 Abstain: 0

**4. Consideration to Approve Resolution Confirming Report on Sewer Service Charges for West Bay Sanitary District for the Fiscal Year 2020/2021**

Motion to Approve by: Walker 2<sup>nd</sup> by: Thiele-Sardiña Vote: AYE: 4 NAY: 0 Abstain: 0

Comments: None.

**5. Consideration to Approve Maintenance Contract with HACH**

Motion to Approve by: Otte 2<sup>nd</sup> by: Thiele-Sardiña Vote: AYE: 4 NAY: 0 Abstain: 0

Comments: Water Quality Manager Beyer reported we have not received any feedback since the District sent the "Letter of Intent." The Board approved the Maintenance Contract subject to Legal Council's review.

## 6. District Manager's Report

### 1) CIP Project:

- a. **Cleaning and Inspecting Large Diameter lines:** Crews are working on cleaning and televising the large diameter sewer lines; 36" From Alpine Road to the Menlo Park Pump Station at Bayfront. To date cleaning and inspections have been completed from Alpine Road to Highway 101.
- b. **Levee Improvement Project:** We concluded the comment period of the Public Notice of Preparation meeting held by Zoom on June 3, 2020; as required for the drafting of the Environmental Impact Report. No out of the ordinary comments have been received.
- c. **Conditions to Operate at Sharon Heights** – Water Board had to revise the draft Notice of Applicability and will be resubmitting to their supervisor. They would like to share the draft with our team early next week, and then after receiving feedback, the last step will be approval and signature by their Division Chief. Staff is following the matter closely.

### 2) Affiliate Agency/Association News:

- a. **CMPK:** Building permit application has been submitted for Metal Building at FERRF and is being reviewed by CMPK. DPW has put in a good word to the Building Department to help expedite the process; however, many of their staff are still working from home. We will continue to work with Menlo Park to issue the District's building permit.

### 3) Operations and Maintenance:

- a. **Vacancy:** Selected New Operations Superintendent
- b. **Menlo Park:** The City terminated the Vehicle Maintenance Service Agreement. Menlo Park has yet to respond with their rationale behind their decision. The District is reviewing other government entities or private firms whom would like the extra revenue from such contract. Treasurer Thiele-Sardiña reported he was on the call with the City of Menlo Park as they discussed canceling the Maintenance Service Agreement between Menlo Park and West Bay. He attempted to explain to the City Council about the benefits of the agreement; however, the City Council directed staff to cancel the agreement. President Dehn suggested Staff let Menlo Park know the District is interested in keeping the agreement in place on an "As-Needed" basis. District Manager Ramirez agreed to contact Menlo Park but he will also pursue Redwood City and the City of Palo Alto to obtain their services and offer them the potential revenue from such maintenance service contract.

### 4) Upcoming Events:

**Board meetings:** The July 22, 2020 Regular Board Meeting was canceled. The Annual Goals Luncheon will be held on July 29, 2020 at the District's Admin and Maintenance Facilities where Staff will present Annual/Fiscal Goals. The next Regular Board Meeting will be held on August 12, 2020.

### 5) Misc./Action Items from Previous Meeting:

- a. **SSOs:** Zero SSO for May. 2020 Total = 0. 13 months in a row w/o SSO.
- b. **LAH:** Zero SSO for May. 2 SSO in 2020.
- c. **Revenue:** Last San Mateo County check for FY20/21 was received on July 1, 2020 in the amount of \$1.2M.

- d. **COVID-19 Update:** 3 month YouTube advertisement advising customers not to flush wipes or towels has been viewed by 220,653 people and 24% or 50,759 have viewed the video to completion with one month remaining.

**7. Consent Calendar**

Motion to Approve by: Otte 2<sup>nd</sup> by: Thiele-Sardiña Vote: AYE: 4 NAY: 0 Abstain: 0

**CONSIDERATION OF ITEM(S) REMOVED FROM THE CONSENT CALENDAR**

Comments:

President Dehn inquired about the “Spraying at Flo Equal at FERRF” an item on the Withdrawal Order. District Manager Ramirez reported this item was to pay for weed abatement at the Flow Equalization & Resource Recovery Facility.

- A. Approval of Minutes for Regular meeting June 24, 2020
- B. Approval of the Withdrawal Order Authorizing Payment of Certain Bills and Salaries and Consideration of Other Financial Matters for July 8, 2020
- C. WBSD Operations and Maintenance Report – June 2020
- D. Town of Los Altos Hills Operations and Maintenance Report for Work Performed by WBSD – June 2020

**8. Discussion of LAFCo Call for Nominations**

Motion to Approve by: \_\_\_\_\_ 2<sup>nd</sup> by: \_\_\_\_\_ Vote: ~~AYE:~~ ~~NAY:~~ ~~Abstain:~~

Comments: President Dehn directed Staff to reach out to absent Director Moritz in order to find out if he is interested in running for the LAFCo Board.

**9. July 8<sup>th</sup> Update Report on District Response to Corona Virus**

Comments: District Manager Ramirez reported on the Corona Virus induced “No Wipes” media campaign on YouTube. He reported the campaign is going well. So far the 3 month ad has received almost 51,000 views. President Dehn asked to see data on who, when, and where people are viewing our ad and asked if we can find out on what device they are viewing it on (such as smart phone, tablets, PC, etc.) She requested to see the bell curve on such data.

District Manager Ramirez reported on one of the District’s staff members parents has tested positive for COVID-19. The staff member was asked to stay home through July 10<sup>th</sup> to allow for a 14 day quarantine. July 10<sup>th</sup> would be 14 days after his encounter with a now known COVID-19 patient. President Dehn, asked if the staff member could work or prepare for technical certification exams from home while in self quarantine.

**10. Discussion and Direction on Recycled Water Projects - Sharon Heights & Bayfront, Including Project Status**

Comments: District Manager Ramirez reported the State Water Board may be days away from giving the District the “Notice of Applicability” permit in order to deliver water to the Sharon Heights Golf and Country Club. He also discussed an odor issue Staff has been diligently working on. District Crews installed a clean out to a lateral on the golf course to help address the odor issues and to allow for monitoring.

**11. Report & Discussion on South Bayside Waste Management Authority (SBWMA)**

Comments: President Dehn reported on Recology’s plan to convert their current solid waste and recycling fleet to an all-electric environmentally friendly fleet by 2024. She reported the SBWMA JPA has approved an insurance agreement allowing for higher deductibles while maintaining a lower premium. President Dehn also reported on the JPA’s efforts to change their budget to a calendar budget beginning in January 2021. Budget meetings will resume in September or October for the 2021 calendar year budget.

**12. Report, Discussion & Direction on Silicon Valley Clean Water (SVCW) and Discussion on SVCW CIP Program and Financing**

Comments: Treasurer Thiele-Sardiña stated SVCW Manager Teresa Herrera has done a great job with the SVCW newsletter. Director Otte reported SVCW will be hosting tours of the large diameter pipeline over the next two weeks. The tour will consist of walking the 1.5 mile long pipeline. The next SVCW meeting will be held on July 19, 2020.

**14. Closed Session**

Entered closed session at 7:57 p.m. Left closed session at 8:41 p.m.

Reportable action: None.

Comments: No need to place existing litigation item on Agenda if there is nothing to report. DC Condotti will let Staff know when it needs to be added.

- A. PUBLIC EMPLOYEE PERFORMANCE EVALUATION:  
Title: District Manager
- B. CONFERENCE WITH LABOR NEGOTIATORS  
(Pursuant to Cal. Govt. Code §54957.6) Agency designated representatives: Board President/Legal Counsel  
Unrepresented Employee: Finance Manager
- C. CONFERENCE WITH LEGAL COUNSEL—EXISTING LITIGATION  
(Subdivision (a) of Section 54956.9)  
Chan, Moreno, Vestnys, Pebbles v. WBSD – San Mateo County Court Case No. 19CIV07567
- D. CONFERENCE WITH LEGAL COUNSEL – EXISTING LITIGATION  
(Cal. Govt. Code §54956.9(d))  
Name of Case: *1740 Oak Avenue, LP v. West Bay Sanitary District, et al.* – SMCS  
Case No. 18CIV02183



**17. Comments or Reports from Members of the District Board and Consider Items to be Placed on Future Agenda**

Comments: Board wishes to see the Top 10 Commercial users of 2017, 2018, and 2019 for the purpose of water data and trend of 2020 water usage. Consider placing it on the Agenda in early 2021.

**18. Adjournment Time:** The meeting was adjourned at 8:42 PM

---

Secretary

THIS PAGE LEFT INTENTIONALLY BLANK

**WEST BAY SANITARY DISTRICT  
WITHDRAWAL ORDER  
July 1, 2020 through August 3, 2020**

| CHECK | DATE      | TO WHOM PAYABLE                | PURPOSE  | AMOUNT    |
|-------|-----------|--------------------------------|--|-----------|
| 66763 | 6/30/2020 | SAN MATEO COUNTY ASSESSOR      | Assessment Roll I  | 305.00    |
| 66764 | 7/7/2020  | MATHESON TRI-GAS, INC.         | Cylinder Rentals   | 52.28     |
| 66765 | 7/7/2020  | ALL FENCE COMPANY, INC.        | Menlo Industrial Pump Station - Fence Windscreen                   | 1,040.00  |
| 66766 | 7/7/2020  | ALLIANT INSURANCE SERVICES     | Equipment Insurance - FY 2020-21                                   | 18,218.00 |
| 66767 | 7/7/2020  | AMERICAN TEXTILE & SUPPLY      | PPE: N95 Masks (20,000)  | 1,872.90  |
| 66768 | 7/7/2020  | READYREFRESH BY NESTLE         | Water Delivery (25 cases)  | 215.70    |
| 66769 | 7/7/2020  | BAY ALARM                      | Alarm Monitoring   | 4,149.42  |
| 66770 | 7/7/2020  | Bayside Equipment Company      | Vehicle Repairs Unit 218   | 1,430.42  |
| 66771 | 7/7/2020  | WEX BANK                       | Fuel Purchases 6/2020  | 79.20     |
| 66772 | 7/7/2020  | Cintas Corp.                   | Uniform Services 7/2020  | 771.07    |
| 66773 | 7/7/2020  | COMCAST                        | Internet   | 277.45    |
| 66774 | 7/7/2020  | NAVIA BENEFIT SOLUTIONS        | Commuter Minimum Fee 6/2020  | 25.00     |
| 66775 | 7/7/2020  | KIMBALL MIDWEST                | Misc Operating Supplies - Clamps, Bolts, Cable Ties, DOT Air Lines | 1,978.24  |
| 66776 | 7/7/2020  | BOB HULSMANN                   | Costco Reimbursement   | 1,096.15  |
| 66777 | 7/7/2020  | INSTRUMENT TECHNOLOGY CORP.    | Mini Push Camera   | 5,472.81  |
| 66778 | 7/7/2020  | MALLORY CO.                    | Safety Equipment - Sensors   | 4,412.00  |
| 66779 | 7/7/2020  | SUTTER EAP                     | Q1 & Q2 EAP Charges  | 826.50    |
| 66780 | 7/7/2020  | OGASAWARA LANDSCAPE MAINT.     | Building Maintenance 6/2020  | 700.00    |
| 66781 | 7/7/2020  | Peninsula Building Supply      | Misc Operating Supplies  | 118.09    |
| 66782 | 7/7/2020  | Priority 1 Public Safety       | Unit 208 Service Truck   | 7,908.96  |
| 66783 | 7/7/2020  | TODD REESE                     | Payroll Adj: Reim Rejected Direct Deposit                          | 500.00    |
| 66784 | 7/7/2020  | SAN MATEO COUNTY CLERK         | Limited Sewer Service Agmt: 491 Fletcher Dr                        | 26.00     |
| 66785 | 7/7/2020  | SEEKZEN SYSTEMS                | Service Plan Monthly Fee 6/2020                                    | 475.00    |
| 66786 | 7/7/2020  | ZANKER RECYCLING               | Misc Operating Supplies - Charge 10/2019                           | 51.77     |
| 66787 | 7/13/2020 | CWEA                           | CWEA - ECI 1 Test  | 180.00    |
| 66788 | 7/13/2020 | NAVIA BENEFIT SOLUTIONS        | Flexible Spending Account PR Contributions                         | 525.39    |
| 66789 | 7/13/2020 | FRANCHISE TAX BOARD            | Earnings Withholding Order   | 250.00    |
| 66790 | 7/13/2020 | SAN MATEO COUNTY CLERK         | Limited Sewer Service Agmt: 95 Mesa Ct, ATH                        | 20.00     |
| 66791 | 7/13/2020 | SAN MATEO COUNTY CLERK         | Quitclaim Deed of Easement - Orig paid \$23                        | 6.00      |
| 66792 | 7/13/2020 | TEAMSTERS LOCAL NO. 350        | July-Union Dues  | 1,020.00  |
| 66793 | 7/14/2020 | AMERICAN TEXTILE & SUPPLY      | Towels   | 86.68     |
| 66794 | 7/14/2020 | AMERICAN MESSAGING             | Pager Service 7/2020   | 64.57     |
| 66795 | 7/14/2020 | ATCHISON, BARISONE & CONDOTTI  | Legal Services 6/2020  | 7,790.67  |
| 66796 | 7/14/2020 | BAY ALARM                      | Alarm Monitoring 6/2020  | 4,418.70  |
| 66797 | 7/14/2020 | Bayside Equipment Company      | Unit 216 Generator Repair  | 811.49    |
| 66798 | 7/14/2020 | CALPERS LONG-TERM CARE PROGRAM | LTC Withholding 7/2020   | 35.36     |
| 66799 | 7/14/2020 | CITY OF FOSTER CITY            | Job Posting 6/2020   | 500.00    |
| 66800 | 7/14/2020 | DOLPHIN GRAPHICS               | Employee Hats 6/2020   | 763.61    |
| 66801 | 7/14/2020 | DU-ALL SAFETY, LLC             | Safety Training 6/2020   | 1,620.00  |
| 66802 | 7/14/2020 | EMBARCADERO MEDIA              | Advertisement 6/2020   | 396.00    |
| 66803 | 7/14/2020 | FINISHMASTER INC               | Fleet Paint Unit 208 6/2020  | 459.36    |
| 66804 | 7/14/2020 | FREMONT URGENT CARE            | Physician 6/2020   | 145.00    |
| 66805 | 7/14/2020 | FREYER & LAURETA               | Wall Maps 6/2020   | 2,009.52  |
| 66806 | 7/14/2020 | GOVERNMENTJOBS.COM DBA NEOGOV  | Subscription Fee 7/2020-7/2021                                     | 3,778.32  |
| 66807 | 7/14/2020 | Home Depot                     | Sprinkler Parts for Admin 6/2020                                   | 1,283.25  |
| 66808 | 7/14/2020 | INSTRUMENT TECHNOLOGY CORP.    | Lateral Camera Repair 6/2020                                       | 1,562.82  |
| 66809 | 7/14/2020 | JANI-KING OF CA, INC - SFR/OAK | Custodial Service 7/2020   | 743.31    |
| 66810 | 7/14/2020 | KONE INC.                      | Elevator Maintenance 7/2020  | 267.12    |
| 66811 | 7/14/2020 | LOG ME IN                      | Computer Software 7/2020   | 67.33     |
| 66812 | 7/14/2020 | CITY OF MENLO PARK - Water     | Water Service 6/2020   | 54.65     |
| 66813 | 7/14/2020 | City of Menlo Park - Repair    | Vehicle Repairs & Maintenance 6/2020                               | 3,857.31  |
| 66814 | 7/14/2020 | CITY OF MENLO PARK-Fuel        | Fuel 6/2020  | 4,284.99  |
| 66815 | 7/14/2020 | ABILA                          | Abila Acctg Software 8/2020-7/2021                                 | 4,366.00  |
| 66816 | 7/14/2020 | Peninsula Building Supply      | Misc Operating Supplies FEF 6/2020                                 | 67.78     |
| 66817 | 7/14/2020 | Rich Voss Trucking             | Drain Rock 6/2020  | 406.00    |
| 66818 | 7/14/2020 | Roberts & Brune Company        | Misc. Operating Supplies   | 1,578.93  |
| 66819 | 7/14/2020 | SAN MATEO COUNTY               | Pump Station Permit 7/2020   | 849.00    |
| 66820 | 7/14/2020 | SHARP BUSINESS SYSTEMS         | Copier 7/2020  | 1,036.78  |
| 66821 | 7/14/2020 | SONSRAY MACHINERY LLC          | Backhoe Repair 6/2020  | 2,140.51  |
| 66822 | 7/20/2020 | AAA Rentals                    | Misc Equipment 6/2020  | 184.00    |
| 66823 | 7/20/2020 | ACCESS                         | Document Destruction 6/2020  | 110.00    |

**WEST BAY SANITARY DISTRICT  
WITHDRAWAL ORDER  
July 1, 2020 through August 3, 2020**

|       |           |                                |  |            |
|-------|-----------|--------------------------------|--|------------|
| 66824 | 7/20/2020 | READYREFRESH BY NESTLE         | Water 6/2020   | 28.47      |
| 66825 | 7/20/2020 | Cintas Corp.                   | Uniform Services 7/2020                                    | 1,848.52   |
| 66826 | 7/20/2020 | FINISHMASTER INC               | Manhole Supplies 6/2020                                    | 185.96     |
| 66827 | 7/20/2020 | FREYER & LAURETA               | Levee Design, ECI Consultation, CIP North Bay Rd, Misc Eng | 136,210.13 |
| 66828 | 7/20/2020 | KANTOR'S FURNITURE             | Office Furniture 6/2020                                    | 6,610.63   |
| 66829 | 7/20/2020 | Mid State Container Sales, Inc | PO-030034-20 Foot Storage Container                        | 2,800.00   |
| 66830 | 7/20/2020 | PIER 2 MARKETING               | Computer Maintenance 7/2020                                | 800.00     |
| 66831 | 7/20/2020 | PONTON INDUSTRIES, INC.        | Operating Supplies - Coll                                  | 1,474.88   |
| 66832 | 7/20/2020 | PREFERRED ALLIANCE             | Admin Fee DOT Drivers 6/2020                               | 235.98     |
| 66833 | 7/20/2020 | PRINCIPAL LIFE INSURANCE CO.   | Life, LTD & Health 7/2020                                  | 4,790.90   |
| 66834 | 7/20/2020 | Roberts & Brune Company        | Construction Supplies 7/2020                               | 3,014.06   |
| 66835 | 7/20/2020 | Towne Ford Sales               | Vehicle Repair Unit 208 7/2020                             | 318.17     |
| 66836 | 7/20/2020 | V & A CONSULTING ENGINEERS     | Flow Monitoring 6/2020                                     | 7,060.00   |
| 66837 | 7/20/2020 | VISION COMMUNICATIONS CO.      | Radio Service Agreement 7/2020                             | 690.49     |
| 66838 | 7/28/2020 | AT&T                           | Long Distance 6/2020                                       | 985.79     |
| 66839 | 7/28/2020 | READYREFRESH BY NESTLE         | Water 6/2020   | 439.59     |
| 66840 | 7/28/2020 | CALPERS LONG-TERM CARE PROGRAM | Long Term Care Withholding 7/2020                          | 35.36      |
| 66841 | 7/28/2020 | WEX BANK                       | Fuel 7/2020  | 258.24     |
| 66842 | 7/28/2020 | COMCAST                        | Internet 7/2020  | 277.45     |
| 66843 | 7/28/2020 | DELL MARKETING L.P.            | Windows Server Std Per 2 Core Licenses MOLP 2019           | 984.00     |
| 66844 | 7/28/2020 | FEDERAL EXPRESS                | Shipping Charges 6/2020                                    | 325.41     |
| 66845 | 7/28/2020 | NAVIA BENEFIT SOLUTIONS        | Flexible Spending Account PR Contributions                 | 525.39     |
| 66846 | 7/28/2020 | FRANCHISE TAX BOARD            | Earnings Withholding Order                                 | 250.00     |
| 66847 | 7/28/2020 | CITY OF MENLO PARK             | Water Service - 6/2020                                     | 2,675.82   |
| 66848 | 7/28/2020 | QUADIENT LEASING USA, INC.     | Postage Meter Lease 8/10/2020 - 11/9/2020                  | 268.25     |
| 66849 | 7/28/2020 | OCCASIONS, ETC.                | Retirement Plaque P.Scott 6/2020                           | 27.75      |
| 66850 | 7/28/2020 | OGASAWARA LANDSCAPE MAINT.     | Building Maintenance 7/2020                                | 400.00     |
| 66851 | 7/28/2020 | PONTON INDUSTRIES, INC.        | Telemetry Service - Verizon                                | 8,280.00   |
| 66852 | 7/28/2020 | SERGIO RAMIREZ                 | Tuition Reimbursement                                      | 4,001.62   |
| 66853 | 7/28/2020 | RANGER PIPELINES               | Alpine Road Project 7/2020                                 | 39,646.99  |
| 66854 | 7/28/2020 | STAPLES CREDIT PLAN            | Office Supplies 6/2020                                     | 1,542.46   |
| 66855 | 7/28/2020 | WOODARD & CURRAN               | Sampling Analysis & Discharge Support 6/2020               | 2,063.25   |
| 66856 | 8/3/2020  | BAY AREA AIR QUALITY MGMT DIST | Annual Permit Renewal 7/2020                               | 391.00     |
| 66857 | 8/3/2020  | CENTER FOR HEARING HEALTH INC. | Annual Audiometric Testing 7/2020                          | 600.00     |
| 66858 | 8/3/2020  | Cintas Corp.                   | Uniform Services 7/2020                                    | 1,551.28   |
| 66859 | 8/3/2020  | HEATH CORTEZ                   | 15 Year Service Award                                      | 225.00     |
| 66860 | 8/3/2020  | DEWEY PEST CONTROL             | Rodent Control 7/2020                                      | 164.00     |
| 66861 | 8/3/2020  | R.A. NOSEK INVESTIGATIONS      | Screening Reports 7/2020                                   | 1,180.00   |
| 66862 | 8/3/2020  | PACIFIC GAS & ELECTRIC         | Gas & Electric Service 7/2020                              | 15,547.64  |
| 66863 | 8/3/2020  | SAN MATEO COUNTY CLERK         | Limited Sewer Service: 269 Marmona Ct, MP                  | 20.00      |
| 66864 | 8/3/2020  | SAN MATEO COUNTY CLERK         | Limited Sewer Service: 491 Fletcher Dr, MP                 | 14.00      |
| 66865 | 8/3/2020  | HENRY SANTOS                   | 10 Year Service Award                                      | 150.00     |
| 66866 | 8/3/2020  | TEAMSTERS LOCAL NO. 350        | Union Dues 8/2020  | 1,020.00   |
| 66867 | 8/3/2020  | VISION COMMUNICATIONS CO.      | Hand Held Walkie Talkie Repair                             | 440.00     |

**TOTAL CHECKS**

**350,100.89**

CORPORATE CARDS:

| GL    | DATE      | Account Number & Name          | Description   | Amount   |
|-------|-----------|--------------------------------|---|----------|
| 54083 | 7/15/2020 | Memberships                    | CWEA: Membership And Renewal                              | 198.00   |
| 54091 | 7/15/2020 | Stationary and Office Supplies | Office Supplies   | 773.34   |
| 54101 | 7/15/2020 | Ops Supplies & Materials       | Office Supplies   | 971.12   |
| 54102 | 7/15/2020 | Safety Supplies & Materials    | Ace Hardware: Paint Supplies                              | 353.48   |
| 54106 | 7/15/2020 | Small Tools                    | Home Depot: AC Unit                                       | 525.66   |
| 54131 | 7/15/2020 | Advertisement & Legal Notices  | PBP Compliance: DOL State And Fed Posters For 4 Buildings | 937.00   |
| 54151 | 7/15/2020 | Fleet/Vehicle R&M              | Mission Valley Ford: Unit 210 Caliper Bolts               | 8.89     |
| 54158 | 7/15/2020 | Computer Software R&M          | Video Conference Annual Renewal / Microsoft Subscription  | 171.24   |
| 54159 | 7/15/2020 | Computer Hardware R & M        | Dell: Computer Replacement Program                        | 877.52   |
| 54174 | 7/15/2020 | Mgmt Conf. & District Meetings | Manager's Meeting, Interviews, Board Meeting              | 281.46   |
| 54175 | 7/15/2020 | CWEA Conf/Section Mtgs         | Regional Gov: Training                                    | 75.00    |
| 54176 | 7/15/2020 | Business Meetings              | Business Meetings, Interview Panels, SSO Lunch            | 215.42   |
| 54192 | 7/15/2020 | Telephone                      | TPZ Communications: Phone Service                         | 2,281.92 |
| 54194 | 7/15/2020 | Water                          | CalWater: Water Service                                   | 1,996.34 |

**WEST BAY SANITARY DISTRICT  
WITHDRAWAL ORDER  
July 1, 2020 through August 3, 2020**

|                               |           |                               |                              |                  |
|-------------------------------|-----------|-------------------------------|------------------------------|------------------|
| 54195                         | 7/15/2020 | Electricity                   | PG&E: Gas & Electric Service | 20,704.93        |
| 54202                         | 7/15/2020 | Other Misc. Operating Expense | Fastrak: Commuter Program    | 550.00           |
| 54083                         | 7/15/2020 | Memberships                   | CWEA: Membership And Renewal | 281.00           |
| <b>TOTAL CORPORATE CARDS:</b> |           |                               |                              | <b>31,202.32</b> |

WIRE TRANSFERS

| DATE                                     | TO WHOM PAYABLE  | PURPOSE                                | AMOUNT              |
|--|------------------|--|---------------------|
| 7/2/2020                                 | PrimePay         | Employee Payroll - Pay Period 6/19-7/3 | 99,871.55           |
| 7/2/2020                                 | PrimePay         | Federal Payroll Taxes                  | 21,108.17           |
| 7/2/2020                                 | PrimePay         | State Payroll Taxes                    | 6,552.52            |
| 7/2/2020                                 | ICMA             | Deferred Compensation                  | 9,204.74            |
| 7/5/2020                                 | PrimePay         | PrimePay Fees                          | 606.08              |
| 7/10/2020                                | CalPERs          | Health Premium                         | 52,363.59           |
| 7/17/2020                                | PrimePay         | Employee Payroll - Pay Period 7/3-17   | 107,864.50          |
| 7/17/2020                                | PrimePay         | Federal Payroll Taxes                  | 21,905.99           |
| 7/17/2020                                | PrimePay         | State Payroll Taxes                    | 7,600.75            |
| 7/17/2020                                | ICMA             | Deferred Compensation                  | 9,052.53            |
| 7/24/2020                                | Bank of New York | 2014 SVCW Bond                         | 391,929.21          |
| 7/24/2020                                | Bank of New York | 2015 SVCW Bond                         | 1,107,625.00        |
| 7/27/2020                                | Zions Bank       | 2018 SVCW Bonds                        | 1,203,293.75        |
| 7/28/2020                                | CalPERs          | Pay Down Unfunded Liability            | 1,600,000.00        |
| 7/30/2020                                | CalPERs          | Unfunded Accrued Liability             | 382,655.00          |
| 7/31/2020                                | PrimePay         | Employee Payroll - Pay Period 7/17-31  | 111,549.95          |
| 7/31/2020                                | PrimePay         | Directors Fees 7/2020                  | 2,502.41            |
| 7/31/2020                                | PrimePay         | Federal Payroll Taxes                  | 22,189.16           |
| 7/31/2020                                | PrimePay         | State Payroll Taxes                    | 7,024.23            |
| 7/31/2020                                | ICMA             | Deferred Compensation                  | 8,922.09            |
| 8/1/2020                                 | SVCW             | August Operating Expense               | 636,710.00          |
| <b>WIRE TRANSFERS FROM BoFw CHECKING</b> |                  |  | <b>5,810,531.22</b> |

Summary

|                 |              |
|-----------------|--------------|
| TOTAL CHECKS    | 350,100.89   |
| TOTAL CORP CARD | 31,202.32    |
| TOTAL WIRES     | 5,810,531.22 |

**TOTAL WITHDRAWALS** **6,191,834.43**

Summary by Budget Category

|            |                     |
|------------|---------------------|
| Operations | 6,149,387.44        |
| Capital    | 42,446.99           |
| SHGCC      | 0.00                |
|            | <b>6,191,834.43</b> |

President \_\_\_\_\_

Secretary \_\_\_\_\_

**WEST BAY SANITARY DISTRICT  
WITHDRAWAL ORDER  
SUPPLEMENTAL PURCHASE REGISTER  
July 1, 2020 through August 3, 2020**

**OPERATING SUPPLIES & OFFICE EXPENSE**

| <u>CHECK</u> | <u>DATE</u> | <u>VENDOR</u>                 | <u>DESCRIPTION</u>   | <u>AMOUNT</u> |
|--------------|-------------|-------------------------------|--|---------------|
| 66766        | 7/7/2020    | ALLIANT INSURANCE SERVICES    | Equipment Insurance - FY 2020-21                                   | 18,218.00     |
| 66767        | 7/7/2020    | AMERICAN TEXTILE & SUPPLY     | PPE: N95 Masks (20,000)  | 1,872.90      |
| 66769        | 7/7/2020    | BAY ALARM                     | Alarm Monitoring   | 4,149.42      |
| 66775        | 7/7/2020    | KIMBALL MIDWEST               | Misc Operating Supplies - Clamps, Bolts, Cable Ties, DOT Air Lines | 1,978.24      |
| 66776        | 7/7/2020    | BOB HULSMANN                  | Costco Reimbursement - Supplies                                    | 1,096.15      |
| 66777        | 7/7/2020    | INSTRUMENT TECHNOLOGY CORP.   | Mini Push Camera   | 5,472.81      |
| 66778        | 7/7/2020    | MALLORY CO.                   | Safety Equipment - Sensors   | 4,412.00      |
| 66792        | 7/13/2020   | TEAMSTERS LOCAL NO. 350       | July-Union Dues  | 1,020.00      |
| 66795        | 7/14/2020   | ATCHISON, BARISONE & CONDOTTI | Legal Services 6/2020  | 7,790.67      |
| 66796        | 7/14/2020   | BAY ALARM                     | Alarm Monitoring 6/2020  | 4,418.70      |
| 66801        | 7/14/2020   | DU-ALL SAFETY, LLC            | Safety Training 6/2020   | 1,620.00      |
| 66805        | 7/14/2020   | FREYER & LAURETA              | Wall Maps 6/2020   | 2,009.52      |
| 66806        | 7/14/2020   | GOVERNMENTJOBS.COM DBA NEOGOV | Subscription Fee 7/2020-7/2021                                     | 3,778.32      |
| 66807        | 7/14/2020   | Home Depot                    | Sprinkler Parts for Admin 6/2020                                   | 1,283.25      |
| 66808        | 7/14/2020   | INSTRUMENT TECHNOLOGY CORP.   | Lateral Camera Repair 6/2020                                       | 1,562.82      |
| 66815        | 7/14/2020   | ABILA                         | Abila Acctg Software 8/2020-7/2021                                 | 4,366.00      |
| 66818        | 7/14/2020   | Roberts & Brune Company       | Misc. Operating Supplies   | 1,578.93      |
| 66820        | 7/14/2020   | SHARP BUSINESS SYSTEMS        | Copier 7/2020  | 1,036.78      |
| 66825        | 7/20/2020   | Cintas Corp.                  | Uniform Services 7/2020  | 1,848.52      |
| 66828        | 7/20/2020   | KANTOR'S FURNITURE            | Office Furniture 6/2020  | 6,610.63      |
| 66831        | 7/20/2020   | PONTON INDUSTRIES, INC.       | Operating Supplies - Coll  | 1,474.88      |
| 66833        | 7/20/2020   | PRINCIPAL LIFE INSURANCE CO.  | Life, LTD & Health 7/2020  | 4,790.90      |
| 66834        | 7/20/2020   | Roberts & Brune Company       | Construction Supplies 7/2020                                       | 3,014.06      |
| 66836        | 7/20/2020   | V & A CONSULTING ENGINEERS    | Flow Monitoring 6/2020   | 7,060.00      |
| 66847        | 7/28/2020   | CITY OF MENLO PARK            | Water Service - 6/2020   | 2,675.82      |
| 66851        | 7/28/2020   | PONTON INDUSTRIES, INC.       | Telemetry Service - Verizon  | 8,280.00      |
| 66852        | 7/28/2020   | SERGIO RAMIREZ                | Tuition Reimbursement  | 4,001.62      |
| 66854        | 7/28/2020   | STAPLES CREDIT PLAN           | Office Supplies 6/2020   | 1,542.46      |
| 66855        | 7/28/2020   | WOODARD & CURRAN              | Sampling Analysis & Discharge Support 6/2020                       | 2,063.25      |
| 66858        | 8/3/2020    | Cintas Corp.                  | Uniform Services 7/2020  | 1,551.28      |
| 66862        | 8/3/2020    | PACIFIC GAS & ELECTRIC        | Gas & Electric Service 7/2020                                      | 15,547.64     |
| 66866        | 8/3/2020    | TEAMSTERS LOCAL NO. 350       | Union Dues 8/2020  | 1,020.00      |

**MISCELLANEOUS**

| <u>CHECK</u> | <u>DATE</u> | <u>VENDOR</u>                  | <u>DESCRIPTION</u>   | <u>AMOUNT</u> |
|--------------|-------------|--------------------------------|--|---------------|
| 66765        | 7/7/2020    | ALL FENCE COMPANY, INC.        | Menlo Industrial Pump Station - Fence Windscreen           | 1,040.00      |
| 66770        | 7/7/2020    | Bayside Equipment Company      | Vehicle Repairs Unit 218                                   | 1,430.42      |
| 66782        | 7/7/2020    | Priority 1 Public Safety       | Unit 208 Service Truck                                     | 7,908.96      |
| 66813        | 7/14/2020   | City of Menlo Park - Repair    | Vehicle Repairs & Maintenance 6/2020                       | 3,857.31      |
| 66814        | 7/14/2020   | CITY OF MENLO PARK-Fuel        | Fuel 6/2020  | 4,284.99      |
| 66821        | 7/14/2020   | SONSRAY MACHINERY LLC          | Backhoe Repair 6/2020                                      | 2,140.51      |
| 66827        | 7/20/2020   | FREYER & LAURETA               | Levee Design, ECI Consultation, CIP North Bay Rd, Misc Eng | 136,210.13    |
| 66829        | 7/20/2020   | Mid State Container Sales, Inc | PO-030034-20 Foot Storage Container                        | 2,800.00      |
| 66853        | 7/28/2020   | RANGER PIPELINES               | Alpine Road Project 7/2020                                 | 39,646.99     |
| 66861        | 8/3/2020    | R.A. NOSEK INVESTIGATIONS      | Screening Reports 7/2020                                   | 1,180.00      |

**WEST BAY SANITARY DISTRICT**  
**SUMMARY OF FY2019-20 PAYMENTS**  
**July 1, 2020 through August 3, 2020**

| <b>REGULAR PAYABLES</b>              | <b>TOTAL BY VENDOR<br/>YTD FY 2020-21</b> | <b>WITHDRAWALS<br/>7/1/2020 - 8/3/2020</b> |
|--------------------------------------|---|--|
| AAA Rentals                          | 184.00                                    | 184.00                                     |
| Abila                                | 4,366.00                                  | 4,366.00                                   |
| Access                               | 110.00                                    | 110.00                                     |
| All Fence Company, Inc.              | 1,040.00                                  | 1,040.00                                   |
| Alliant Insurance Services           | 18,218.00                                 | 18,218.00                                  |
| American Messaging                   | 64.57                                     | 64.57                                      |
| American Textile & Supply            | 1,959.58                                  | 1,959.58                                   |
| AT&T                                 | 985.79                                    | 985.79                                     |
| Atchison, Barisone & Condotti        | 7,790.67                                  | 7,790.67                                   |
| Bank of the West Corp. Cards         | 31,202.32                                 | 31,202.32                                  |
| Bay Alarm                            | 8,568.12                                  | 8,568.12                                   |
| Bay Area Air Quality Mgmt Dist       | 391.00                                    | 391.00                                     |
| Bayside Equipment Company            | 2,241.91                                  | 2,241.91                                   |
| CWEA                                 | 180.00                                    | 180.00                                     |
| CALPERS 1959 Survivor Billing        | -   | -  |
| CALPERS - Unfunded Accrued Liability | 1,982,655.00                              | 1,982,655.00                               |
| CALPERS - Retirement                 | -   | -  |
| CALPERS - Health Premiums            | 52,363.59                                 | 52,363.59                                  |
| Calpers Long-Term Care Program       | 70.72                                     | 70.72                                      |
| Center for Hearing Health Inc.       | 600.00                                    | 600.00                                     |
| Cintas Corp.                         | 4,170.87                                  | 4,170.87                                   |
| Comcast                              | 554.90                                    | 554.90                                     |
| Heath Cortez                         | 225.00                                    | 225.00                                     |
| Dell Marketing L.P.                  | 984.00                                    | 984.00                                     |
| Dewey Pest Control                   | 164.00                                    | 164.00                                     |
| Dolphin Graphics                     | 763.61                                    | 763.61                                     |
| Du-All Safety, Llc                   | 1,620.00                                  | 1,620.00                                   |
| Embarcadero Media                    | 396.00                                    | 396.00                                     |
| Federal Express                      | 325.41                                    | 325.41                                     |
| Fremont Urgent Care                  | 145.00                                    | 145.00                                     |
| Finishmaster Inc                     | 645.32                                    | 645.32                                     |
| City of Foster City                  | 500.00                                    | 500.00                                     |
| Franchise Tax Board                  | 500.00                                    | 500.00                                     |
| Freyer & Laureta                     | 138,219.65                                | 138,219.65                                 |
| Governmentjobs.com dba NeoGov        | 3,778.32                                  | 3,778.32                                   |
| Home Depot                           | 1,283.25                                  | 1,283.25                                   |
| Bob Hulsmann                         | 1,096.15                                  | 1,096.15                                   |
| Instrument Technology Corp.          | 7,035.63                                  | 7,035.63                                   |
| Jani-King of CA, Inc - SFR/OAK       | 743.31                                    | 743.31                                     |
| Kantor's Furniture                   | 6,610.63                                  | 6,610.63                                   |
| Kimball Midwest                      | 1,978.24                                  | 1,978.24                                   |
| Kone Inc.                            | 267.12                                    | 267.12                                     |
| Log Me In                            | 67.33                                     | 67.33                                      |
| Mallory Co.                          | 4,412.00                                  | 4,412.00                                   |
| Matheson Tri-Gas, Inc.               | 52.28                                     | 52.28                                      |
| City of Menlo Park - Repair          | 3,857.31                                  | 3,857.31                                   |
| City of Menlo Park-Fuel              | 4,284.99                                  | 4,284.99                                   |
| City of Menlo Park - Water           | 2,730.47                                  | 2,730.47                                   |
| Mid State Container Sales, Inc       | 2,800.00                                  | 2,800.00                                   |
| Navia Benefit Solutions              | 1,075.78                                  | 1,075.78                                   |
| R.A. Nosek Investigations            | 1,180.00                                  | 1,180.00                                   |
| Occasions, ETC.                      | 27.75                                     | 27.75                                      |
| Ogasawara Landscape Maint.           | 1,100.00                                  | 1,100.00                                   |
| Pacific Gas & Electric               | 15,547.64                                 | 15,547.64                                  |
| Peninsula Building Supply            | 185.87                                    | 185.87                                     |
| Pier 2 Marketing                     | 800.00                                    | 800.00                                     |
| Ponton Industries, Inc.              | 9,754.88                                  | 9,754.88                                   |



**WEST BAY SANITARY DISTRICT**  
**SUMMARY OF FY2019-20 PAYMENTS**  
**July 1, 2020 through August 3, 2020**

| <b>REGULAR PAYABLES</b>                       | <b>TOTAL BY VENDOR<br/>YTD FY 2020-21</b> | <b>WITHDRAWALS<br/>7/1/2020 - 8/3/2020</b> |
|---|---|--|
| Preferred Alliance                            | 235.98                                    | 235.98                                     |
| Principal Life Insurance Co.                  | 4,790.90                                  | 4,790.90                                   |
| Priority 1 Public Safety                      | 7,908.96                                  | 7,908.96                                   |
| Quadient Leasing USA, Inc.                    | 268.25                                    | 268.25                                     |
| Sergio Ramirez                                | 4,001.62                                  | 4,001.62                                   |
| Ranger Pipelines                              | 39,646.99                                 | 39,646.99                                  |
| Readyrefresh By Nestle                        | 683.76                                    | 683.76                                     |
| Todd Reese                                    | 500.00                                    | 500.00                                     |
| Rich Voss Trucking                            | 406.00                                    | 406.00                                     |
| Roberts & Brune Company                       | 4,592.99                                  | 4,592.99                                   |
| SVCW Bond - 2014 Bond                         | 391,929.21                                | 391,929.21                                 |
| SVCW Bond - 2015 Bond                         | 1,107,625.00                              | 1,107,625.00                               |
| SVCW Bond - 2018 Bond                         | 1,203,293.75                              | 1,203,293.75                               |
| SVCW - Monthly Operating Payment              | 636,710.00                                | 636,710.00                                 |
| San Mateo County                              | 849.00                                    | 849.00                                     |
| San Mateo County Assessor                     | 305.00                                    | 305.00                                     |
| San Mateo County Clerk                        | 86.00                                     | 86.00                                      |
| Henry Santos                                  | 150.00                                    | 150.00                                     |
| Seekzen Systems                               | 475.00                                    | 475.00                                     |
| Sharp Business Systems                        | 1,036.78                                  | 1,036.78                                   |
| Sonsray Machinery LLC                         | 2,140.51                                  | 2,140.51                                   |
| Staples Credit Plan                           | 1,542.46                                  | 1,542.46                                   |
| Sutter EAP                                    | 826.50                                    | 826.50                                     |
| Teamsters Local No. 350                       | 2,040.00                                  | 2,040.00                                   |
| Towne Ford Sales                              | 318.17                                    | 318.17                                     |
| V & A Consulting Engineers                    | 7,060.00                                  | 7,060.00                                   |
| Vision Communications Co.                     | 1,130.49                                  | 1,130.49                                   |
| Wex Bank                                      | 337.44                                    | 337.44                                     |
| Woodard & Curran                              | 2,063.25                                  | 2,063.25                                   |
| Zanker Recycling                              | 51.77                                     | 51.77                                      |
| <b>TOTAL REGULAR PAYABLES</b>                 | <b>5,755,879.76</b>                       | <b>5,755,879.76</b>                        |
| <br><b>SALARIES, WAGES &amp; WITHHOLDINGS</b> |   |  |
| Salaries/Wages - Net Pay                      | 319,286.00                                | 319,286.00                                 |
| Directors Fees - Net Pay                      | 2,502.41                                  | 2,502.41                                   |
| PrimePay Fees                                 | 606.08                                    | 606.08                                     |
| IRS - Federal Payroll Taxes                   | 65,203.32                                 | 65,203.32                                  |
| EDD - State Payroll Taxes                     | 21,177.50                                 | 21,177.50                                  |
| ICMA  | 27,179.36                                 | 27,179.36                                  |
| Performance Merit Program - Net Pay           | -   | -  |
| <b>TOTAL SALARIES RELATED</b>                 | <b>435,954.67</b>                         | <b>435,954.67</b>                          |
| <br><b>TOTAL WITHDRAWALS</b>                  | <br><b>6,191,834.43</b>                   | <br><b>6,191,834.43</b>                    |

**WEST BAY SANITARY DISTRICT**  
**Receipts & Incoming Transfers**  
**7/1/2020 - 8/3/2020**

| RECEIPT NUMBER                         | DEPOSIT DATE | DESCRIPTION  | AMOUNT                |
|--|--------------|--|-----------------------|
| 461271                                 | 7/9/2020     | Cell Phone Reim 7/1/20-7/15/20   | 52.37                 |
| 461272                                 | 7/9/2020     | Permit: 33 Spencer Ln, Ath   | 170.00                |
| 461273                                 | 7/9/2020     | Permit: 124 Foxwood Rd   | 290.00                |
| 461274                                 | 7/9/2020     | Permit: 855 Fremont St, MP   | 290.00                |
| 461275                                 | 7/9/2020     | Postage  | 0.50                  |
| 461276                                 | 7/9/2020     | Permit: 1130 Westfield Dr, MP  | 170.00                |
| 461277                                 | 7/9/2020     | Inv 2019/20-040 - 883 Santa Cruz Ave   | 5,131.88              |
| 461278                                 | 7/9/2020     | Permit: 1780 Oakdell Dr, MP  | 460.00                |
| 461279                                 | 7/9/2020     | Permit: 820 Hobart St, MP  | 355.00                |
| 461280                                 | 7/9/2020     | Permit: 2181 Ashton Ave, MP  | 170.00                |
| 461281                                 | 7/9/2020     | Final Settlement   | 8,500.00              |
| 461282                                 | 7/9/2020     | Finishmaster reimbursement   | 298.00                |
| 461283                                 | 7/9/2020     | Permit: 137 Holland St, EPA  | 290.00                |
| 461284                                 | 7/9/2020     | Permit: 95 Mesa Ct, ATH  | 355.00                |
| 461285                                 | 7/9/2020     | Anderson Pacific PG&E Reimbursements: Invoice #2020/21-002   | 32,203.12             |
| 461286                                 | 7/9/2020     | Permit: 89 Victoria Dr, Ath  | 290.00                |
| 461287                                 | 7/9/2020     | Permit: 819 Laurel Ave, MP   | 195.00                |
| 461288                                 | 7/9/2020     | Permit: 3138 Alameda   | 95.00                 |
| 461289                                 | 7/9/2020     | Permit: 2140 Prospect St, MP   | 460.00                |
| 461290                                 | 7/9/2020     | Permit: 440 Linfield Dr  | 290.00                |
| 461291                                 | 7/9/2020     | Permit: 966 & 968 Menlo Ave; \$290/each  | 580.00                |
| 461292                                 | 7/9/2020     | Permit: 908 & 910 Menlo Ave; \$290/each  | 580.00                |
| 461293                                 | 7/9/2020     | Permit: 152 & 154 Stone Pine Ln, \$290/each  | 580.00                |
| 461294                                 | 7/9/2020     | Permit: 1318 University Dr, MP   | 290.00                |
| 461296                                 | 7/30/2020    | Permit: 261 Park Ln, Ath   | 170.00                |
| 461297                                 | 7/30/2020    | VOID   | 0.00                  |
| 461298                                 | 7/30/2020    | 46 Linda Vista Ave   | 2,585.00              |
| 461299                                 | 7/30/2020    | Permit: 33 Spencer Ln  | 290.00                |
| 461300                                 | 7/30/2020    | Permit: 481 Vine St, MP  | 170.00                |
| 461301                                 | 7/30/2020    | Permit: 2105 Monterey Ave, MP  | 290.00                |
| 461302                                 | 7/30/2020    | Permit: 24 Greenoaks Dr, ATH   | 5,815.65              |
| 461304                                 | 7/30/2020    | Permit: 2084 Camino A Los Cerros, MP   | 290.00                |
| 461306                                 | 7/30/2020    | Postage  | 0.80                  |
| 461307                                 | 7/30/2020    | Permit: 735 Menlo Ave, MP  | 290.00                |
| 461308                                 | 7/30/2020    | Permit: 203 Haight St, MP  | 95.00                 |
| 461309                                 | 7/30/2020    | Permit: 1700 Oak Ave, MP   | 290.00                |
| 461310                                 | 7/30/2020    | Unclaimed Property from State  | 291.14                |
| 461311                                 | 7/30/2020    | Permit: 750 Menlo Oaks Drive   | 170.00                |
| 461312                                 | 7/30/2020    | Permit: 611 Woodland Ave - Lot 2   | 8,791.00              |
| 461313                                 | 7/30/2020    | Processing & Publication Fee for 17 Redberry Ridge, PV   | 2,785.00              |
| 461314                                 | 7/30/2020    | Permit: 2100 Prospect St, MP   | 290.00                |
| 461315                                 | 7/30/2020    | 4B Permit: 1031 Sierra Dr \$170; (3) 1A Permits \$290/each: 1031 Sierra, 174 San Andreas Dr, and 125 Garland, MP | 1,040.00              |
| 461316                                 | 7/30/2020    | Permit: 269 Marmona Ct   | 355.00                |
| 461317                                 | 7/30/2020    | Laptop, 2 Phones, Mifi @ \$25 /ea  | 100.00                |
| 461318                                 | 7/30/2020    | Permit: 2050 Santa Cruz Ave - Lot 1, 2 & 3   | 17,872.00             |
| 461319                                 | 7/30/2020    | Permit: 203 Haight St  | 195.00                |
| 461320                                 | 7/30/2020    | Permit: 29 Cowell Ln   | 170.00                |
| 461321                                 | 7/30/2020    | Permit: 441 Gilbert Ave, MP  | 170.00                |
| 461322                                 | 7/30/2020    | Permit: 715 Regal, MP  | 290.00                |
| 461323                                 | 7/30/2020    | Non Routine Discharge Permit #0405   | 1,301.58              |
| 461324                                 | 7/30/2020    | Postage: \$0.50  | 0.50                  |
| 461325                                 | 7/30/2020    | Permit: 1350 N Lemon, MP   | 290.00                |
| 461326                                 | 7/30/2020    | Permit: 1895 Oakdell Dr, MP  | 170.00                |
| 461327                                 | 7/30/2020    | Permit: 30 Cowell, MP  | 290.00                |
| 461328                                 | 7/30/2020    | Permit: 328 Hedge, MP  | 290.00                |
| 461329                                 | 7/30/2020    | Permit: 371 Hedge, MP  | 290.00                |
| 461330                                 | 7/30/2020    | 44 McCormick Lane, ATH   | 4,675.55              |
| 461331                                 | 7/30/2020    | Permit: 752 Gilbert Ave, MP  | 460.00                |
| 461334                                 | 7/30/2020    | 1540 El Camino Real; Connection Fees   | 275,214.50            |
| 461334                                 | 7/30/2020    | Permit: 1540 El Camino Real; Permits   | \$4,440.00            |
| 461336                                 | 7/30/2020    | Permit: 223 Laurel Ave, MP   | \$170.00              |
| 461337                                 | 7/30/2020    | Permit: 16884 - 3122 Barney Ave  | \$8,501.00            |
| 461337                                 | 7/30/2020    | Permit: 16885 - 2020 Manzanita Ave   | \$580.00              |
| 461338                                 | 7/30/2020    | Permit: 7 Fair Oaks, ATH   | \$170.00              |
| <b>Total Deposits</b>                  |              |  | <b>\$391,744.59</b>   |
| <b>WIRE/ACH TRANSFERS RECEIVED</b>     |              |  |                       |
| 461295                                 | 7/1/2020     | Sewer Svc Fees FY 2019-20  | \$1,193,804.25        |
| 461303                                 | 7/13/2020    | SRF Loan Installment #3  | \$67,554.09           |
| 461305                                 | 7/14/2020    | Franchise Fee 6/2020   | \$8,498.04            |
| 461332                                 | 7/23/2020    | Transfer from PARS Pension Trust   | \$1,600,000.00        |
| 461333                                 | 7/23/2020    | Transfer from LAIF   | \$5,000,000.00        |
| <b>Total Transfer to BofW Checking</b> |              |  | <b>\$7,869,856.38</b> |
| <b>TOTAL DEPOSITS</b>                  |              |  | <b>\$8,261,600.97</b> |



**WEST BAY SANITARY DISTRICT  
AGENDA ITEM 5C**

**To: Board of Directors**

**From: Bob Hulsmann, Operations Superintendent**

**Subject: WBSD Operations and Maintenance Report – July 2020**

| Month             | Basin PM Pipe Cleaning<br>Miles | High Freq. PM Pipe Cleaning<br>Miles | Un-Sche. Pipe Cleaning<br>Miles | WBSD CCTV Insp.<br>Miles | Pipe Patch Repairs<br>Qty. | Open Trench Repairs<br>Qty. | Pump Sta. PM<br>Qty. | Pump Sta. Unsch. Repairs<br>Qty. | SSO<br>Cat. 1 | SSO<br>Cat. 2&3s | Service Calls- Unit 208 |            |            |             |
|-------------------|---------------------------------|--------------------------------------|---------------------------------|--------------------------|----------------------------|-----------------------------|----------------------|----------------------------------|---------------|------------------|-------------------------|------------|------------|-------------|
|                   |                                 |                                      |                                 |                          |                            |                             |                      |                                  |               |                  | Call Outs               | Sch        | Unsch.     | USA's       |
|                   |                                 |                                      |                                 |                          |                            |                             |                      |                                  |               |                  |                         | PM         | PM         |             |
| January           | 6.9                             | 4.1                                  | 0.0                             | 3.0                      | 6                          | 7                           | 72                   | 1                                | 0             | 0                | 90                      | 11         | 0          | 206         |
| February          | 5.0                             | 7.8                                  | 0.9                             | 2.5                      | 2                          | 9                           | 69                   | 0                                | 0             | 0                | 95                      | 12         | 0          | 177         |
| March             | 17.3                            | 0.1                                  | 0.4                             | 1.3                      | 4                          | 8                           | 70                   | 0                                | 0             | 0                | 94                      | 9          | 0          | 156         |
| April             | 15.7                            | 3.1                                  | 1.3                             | 0.0                      | 0                          | 0                           | 57                   | 1                                | 0             | 0                | 54                      | 9          | 0          | 152         |
| May               | 8.5                             | 9.6                                  | 0.0                             | 0.2                      | 0                          | 0                           | 50                   | 0                                | 0             | 0                | 71                      | 11         | 0          | 236         |
| June              | 18.4                            | 0.2                                  | 0.4                             | 4.0                      | 6                          | 6                           | 72                   | 0                                | 0             | 0                | 73                      | 3          | 0          | 254         |
| July              | 8.1                             | 4.0                                  | 0.8                             | 1.0                      | 6                          | 9                           | 73                   | 1                                | 0             | 0                | 86                      | 7          | 0          | 217         |
| August            |                                 |                                      |                                 |                          |                            |                             |                      |                                  |               |                  |                         |            |            |             |
| Sept.             |                                 |                                      |                                 |                          |                            |                             |                      |                                  |               |                  |                         |            |            |             |
| * Oct.            | 3.9                             | 4.1                                  | 0.3                             | 4.3                      | 5                          | 8                           | 95                   | 1                                | 0             | 0                | 94                      | 0          | 1          | 309         |
| Nov.              | 0.8                             | 8.2                                  | 0.1                             | 3.2                      | 4                          | 8                           | 83                   | 0                                | 0             | 0                | 105                     | 0          | 3          | 269         |
| Dec               | 13.7                            | 0.0                                  | 0.0                             | 4.6                      | 6                          | 8                           | 76                   | 1                                | 0             | 0                | 88                      |            | 10         | 160         |
| <b>Yr to date</b> | <b>98.4</b>                     | <b>41.2</b>                          | <b>4.2</b>                      | <b>24.0</b>              | <b>39</b>                  | <b>63</b>                   | <b>717</b>           | <b>5</b>                         | <b>0</b>      | <b>0</b>         | <b>850</b>              | <b>62</b>  | <b>14</b>  | <b>2136</b> |
| <b>2020 Goals</b> | <b>120.0</b>                    | <b>50.0</b>                          | <b>n/a</b>                      | <b>45-50</b>             | <b>65</b>                  | <b>90</b>                   | <b>n/a</b>           | <b>&lt;10</b>                    | <b>0-2</b>    | <b>3 to 5</b>    | <b>n/a</b>              | <b>n/a</b> | <b>n/a</b> | <b>n/a</b>  |
| 2019 Goals        | 112.0                           | 48.2                                 | 6.9                             | 42.7                     | 60                         | 86                          | 967                  | 6                                | 0             | 4                | 1063                    | 75         | 33         | 2850        |
| 2018 Results      | 134.2                           | 48.5                                 | 7.4                             | 42.1                     | 66                         | 63                          | 1256                 | 6                                | 0             | 4                | 1139                    | 134        | 89         | 2525        |

**Report to the District Board for the Regular Meeting of August 12, 2020**

|                 |       |      |     |      |    |    |      |    |   |    |     |     |     |      |
|-----------------|-------|------|-----|------|----|----|------|----|---|----|-----|-----|-----|------|
| 2017<br>Results | 126.4 | 51.5 | 5.7 | 24.8 | 66 | 97 | 1265 | 8  | 2 | 3  | 700 | 178 | 61  | 3218 |
| 2016<br>Results | 126.4 | 49   | 6   | 33   | 65 | 94 | 1188 | 5  | 0 | 8  | 798 | 167 | 155 | 3222 |
| 2015Results     | 126.4 | 55   | 21  | 46   | 65 | 90 | 1349 | 6  | 0 | 5  | 798 | 174 | 185 | 2125 |
| 2014Results     | 126.4 | 63   | 20  | 48   | 65 | 78 | 1328 | 10 | 2 | 12 | 771 | 183 | 72  | 1834 |

\* = Beginning of PMPP year.



**WEST BAY SANITARY DISTRICT  
AGENDA ITEM 5D**

**To: Board of Directors**

**From: Bob Hulsmann, Operations Superintendent**

**Subject: Town of Los Altos Hills Operations and Maintenance Report for Work Performed by WBSD – July 2020**

|                      | Basin<br>PM<br>Pipe<br>Clean-<br>ing | High<br>Freq.<br>PM<br>Pipe<br>Clean-<br>ing | Un-<br>Sche.<br>Pipe<br>Clean-<br>ing | WBSD<br>CCTV<br>Insp. | Pump<br>Sta.<br>PM | Pump<br>Sta.<br>Unsch.<br>Repairs | SSO       | SSO          | Service<br>Calls |
|----------------------|--------------------------------------|--|---------------------------------------|-----------------------|--------------------|-----------------------------------|-----------|--------------|------------------|
| Month                |                                      |  |                                       |                       |                    |                                   | Cat.<br>1 | Cat.<br>2&3s | Call<br>Outs     |
| Temp Help            | Miles                                | Miles  | Miles                                 | Miles                 | Qty.               | Qty.                              |           |              |                  |
| January              | 0.5                                  | 0.8  | 0.2                                   | 0.8                   | 4                  | 1                                 | 0         | 0            | 0                |
| February             | 1.3                                  | 0.2  | 0.1                                   | 1.2                   | 4                  | 1                                 | 0         | 1            | 0                |
| March                | 0.0                                  | 1.2  | 0.0                                   | 0.0                   | 4                  | 0                                 | 0         | 0            | 0                |
| April                | 3.2                                  | 1.8  | 0.0                                   | 0.0                   | 4                  | 0                                 | 0         | 0            | 0                |
| May                  | 3.3                                  | 1.3  | 0.1                                   | 0.1                   | 4                  | 0                                 | 0         | 0            | 0                |
| June                 | 1.8                                  | 0.5  | 0.1                                   | 1.9                   | 4                  | 0                                 | 0         | 1            | 0                |
| July                 | 1.4                                  | 1.1  | 0.0                                   | 1.6                   | 4                  | 0                                 | 0         | 0            | 0                |
| *August              | 0.0                                  | 1.2  | 0.0                                   | 0.5                   | 4                  | 0                                 | 0         | 0            | 0                |
| Sept.                | 0.0                                  | 1.5  | 0.0                                   | 1.1                   | 4                  | 0                                 | 0         | 0            | 0                |
| Oct.                 | 0.5                                  | 1.7  | 0.2                                   | 1.2                   | 4                  | 1                                 | 0         | 0            | 0                |
| Nov.                 | 1.0                                  | 1.0  | 0.0                                   | 0.0                   | 4                  | 2                                 | 0         | 0            | 0                |
| Dec                  | 0.0                                  | 1.7  | 0.1                                   | 1.2                   | 4                  | 0                                 | 0         | 0            | 0                |
| <b>** Yr to date</b> | <b>13.0</b>                          | <b>14.0</b>                                  | <b>0.8</b>                            | <b>9.6</b>            | <b>48</b>          | <b>5</b>                          | <b>0</b>  | <b>2</b>     | <b>0</b>         |
| FY19/20Goals         | 17.4                                 | 16.9   | n/a                                   | 9.3                   | 52                 | n/a                               | n/a       | n/a          | n/a              |

\* = August- Start of Contract

THIS PAGE LEFT INTENTIONALLY BLANK



**WEST BAY SANITARY DISTRICT  
AGENDA ITEM 5E**

**To: Board of Directors**

**From: Sergio Ramirez, District Manager  
Debra Fisher, Finance Manager**

**Subject: Consideration to Approve District's Investment Portfolio  
Reports Including Transactions of Assets Described Therein as  
of 6/30/20**

---

Background

On October 27, 2010 the District named Bank of the West as the District's Investment advisor and approved an investment of \$5 million in available funds.

On October 15, 2014, the Board of Directors discussed the District's reserve funds and directed the District Manager to use recent unbudgeted revenues to fund District reserves as close to the predetermined target levels as the revenues would allow. As a result, the District Manager transferred \$3M from the Money Market account on October 29, 2014 to the Investment Portfolio.

On November 19, 2014, the Board of Directors directed the DM to apply additional unbudgeted revenues to the Investment Portfolio, to maneuver closer to the reserve target levels, including adding the Operating Reserves. The District's Operating Fund, equivalent to 5 months operating expense, is designed to bridge the cash flow gap between tax roll receipts from the County from July to December each year. The Board consensus was to fully fund the reserves at target levels. The Operating Reserves change each year to reflect the current budget.

In March 2018 an additional reserve was established to set aside funds from Sharon Heights Golf and Country Club for the required Recycled Water SRF Reserve. \$7.91 million of these funds are held in Local Agency Investment Fund (LAIF), as their yields had outperformed Bank of the West. These funds will be returned to the Investment Portfolio as Bank of the West net returns improve over LAIF.

There are currently six separate reserves maintained to support the goals of the District. Annual contributions are made in accordance with the board approved budget and the Reserve Replenishment Plan to reach the target balances for each reserve.



The District's reserve funds for the fourth quarter 2019-20:

| <b>District Reserves</b><br><b>4/1/2020 - 6/30/2020</b> | <b>Target<br/>Balance</b> | <b>Beginning<br/>Market Value<br/>(millions)</b> | <b>Ending<br/>Market Value<br/>(millions)</b> | <b>Yield</b> |   |
|---|---------------------------|--|---|--------------|---|
| Operating Reserve                                       | \$9.5 million             | \$8.17   | \$9.53  | 2.35%        |   |
| Emergency Capital Reserve                               | \$5 million               | \$3.69   | \$3.90  | 2.32%        |   |
| Capital Project Reserve                                 | \$6 million               | \$2.08   | \$2.78  | 2.77%        |   |
| Rate Stabilization Reserve                              | \$6 million               | \$1.40   | \$1.41  | 3.32%        |   |
| Recycled Water Cash Flow                                | \$8 million               |  |   |              |   |
| Recycled Water Cash Flow Reserve - BofW                 |                           | \$0.23   | \$0.23  | 1.76%        |   |
| Recycled Water Cash Flow Reserve - LAIF                 |                           | \$7.91   | \$7.91  | 1.36%        | * |
| Recycled Water SRF Reserve                              |                           | \$0.85   | \$1.53  | 2.50%        |   |

\* LAIF quarterly apportionment rate.

Analysis

The District transferred \$2,183,000 in the fourth quarter 2019-20, in accordance with the Reserve Replenishment Plan and approved budget; \$1.3 million to the Operating Reserve, \$200 thousand to the Emergency Capital Reserve, and \$683 thousand to the Capital Project Reserve.

Staff will continue to budget for the Reserve Replenishment Plan, as directed, over the next several years to restore reserves to their full target levels.

The district received \$675,540.88 in June from Sharron Heights Golf & Country Club, which was transferred to the SHGCC Recycled Water SRF Reserve.

Fiscal Impact

The investment portfolios have been set up with the goal to yield a rate of return of approximately 2%. Current yields are near or exceed this goal, with yields of 2.32 to 3.32%.

Recommendation

The District Manager recommends the District Board approve the report on the District's Investment Portfolio including the transactions of assets described therein as of 6/30/20.



**WBSD - CAPITAL PROJECT RESERVE**

**Account Number:** 04/01/20 -  
**Statement Period:** 06/30/20

WEST BAY SANITARY DISTRICT  
 ATTN: PHILLIP L. SCOTT  
 500 LAUREL STREET  
 MENLO PARK CA 94025

**Fiduciary**  
 Chuen Ying Lee  
 (408) 645-3234  
**Portfolio**  
 Michael D. Smith  
 (408) 490-2079

**Asset Allocation**

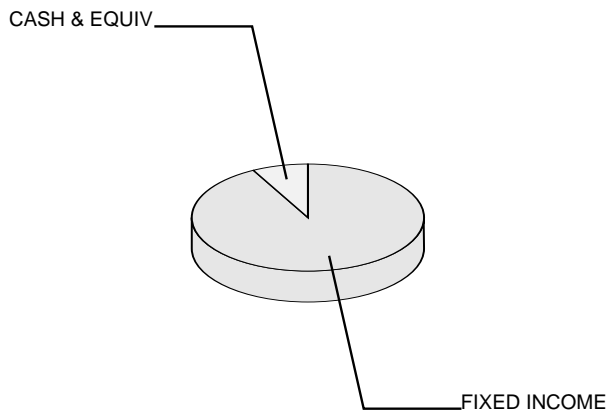

**Asset Valuation**

| Description            | Market Value           | % of Account  |
|------------------------|------------------------|---------------|
| Cash & Equiv           | 223,747.22             | 8.1%          |
| Fixed Income           | 2,532,593.81           | 91.9%         |
| <b>Total Portfolio</b> | <b>\$ 2,756,341.03</b> | <b>100.0%</b> |
| Accrued Income         | 25,533.79              |               |
| <b>Total Valuation</b> | <b>\$ 2,781,874.82</b> |               |

**Market Reconciliation**

|   | Current Period         | Year To Date           |
|---|------------------------|------------------------|
| <b>Beginning Market Value</b>                     | <b>\$ 2,078,824.43</b> | <b>\$ 2,666,749.24</b> |
| Income  |                        |                        |
| Interest.....                                     | 9,684.28               | 56,703.93              |
| Purchased Income.....                             | -9,522.14              | -12,175.54             |
| Additions.....                                    | 683,000.00             | 683,000.00             |
| Disbursements.....                                | -1,300.57              | -642,755.90            |
| Realized Gains/(Losses).....                      | -1.55                  | 1,366.40               |
| Change In Accrued Income.....                     | 16,882.01              | 9,799.45               |
| Change In Market Appreciation/(Depreciation)..... | 6,485.80               | 29,683.07              |
| Non-Cash Asset Changes.....                       | -2,177.44              | -10,495.83             |
| <b>Ending Market Value</b>                        | <b>\$ 2,781,874.82</b> | <b>\$ 2,781,874.82</b> |



**WBSD - CAPITAL PROJECT RESERVE**

Account Number:  
Statement Period:

04/01/20 -  
06/30/20

**Asset Position As of 06/30/20**

| Asset Description   | Units       | Market Value<br>Cost                         | Est. Annual Income<br>Accruals | Current<br>Yield |
|---|-------------|--|--------------------------------|------------------|
| <b>Cash Equivalents</b>   |             |  |                                |                  |
| Bank of The West Advantage Acct   | 223,747.220 | 223,747.22<br>223,747.22                     | 268.00<br>9.92                 | 0.12%            |
| <b>Total Cash Equivalents</b>   |             | <b>\$ 223,747.22</b><br><b>\$ 223,747.22</b> | <b>268.00</b><br><b>9.92</b>   | <b>0.12%</b>     |
| <b>Fixed Income</b>   |             |  |                                |                  |
| Apple Inc Sr Gbl Nt<br>0.75% Dtd 05/11/2020 Due 05/11/2023<br>Callable                                    | 10,000.000  | 10,105.40<br>10,118.70                       | 75.00<br>10.42                 | 0.74%            |
| Austin Tex Indpt Sch Dist Ultd Tax<br>Sch Bldg and RE 5.00% Dtd 04/10/2019<br>Due 08/01/2022 Non-Callable | 100,000.000 | 109,595.00<br>108,780.00                     | 5,000.00<br>2,083.33           | 4.56%            |
| California St GO Bds<br>5.00% Dtd 03/14/2017 Due 08/01/2023<br>Non-Callable                               | 60,000.000  | 68,639.40<br>66,635.40                       | 3,000.00<br>1,249.99           | 4.37%            |
| Citibank NA N Y<br>2.85% Dtd 02/15/2018 Due 02/12/2021<br>Callable  | 32,000.000  | 32,415.68<br>32,265.60                       | 912.00<br>352.13               | 2.81%            |
| Collin Cnty Tex Cmnty College GO Bds<br>2020a 5.00% Dtd 03/15/2020 Due<br>08/15/2021 Non-Callable         | 100,000.000 | 105,306.00<br>104,864.00                     | 5,000.00<br>861.11             | 4.75%            |
| Credit Suisse Ag New York Bran Fr<br>2.80% Dtd 04/09/2020 Due 04/08/2022<br>Non-Callable                  | 20,000.000  | 20,749.40<br>20,728.80                       | 560.00<br>127.55               | 2.70%            |
| Disney Walt Co Sr Gbl Nt<br>1.65% Dtd 09/06/2019 Due 09/01/2022<br>Callable                               | 20,000.000  | 20,465.60<br>20,424.40                       | 330.00<br>110.00               | 1.61%            |
| East Side Un High Sch Dist Cal GO<br>Ref Bds 3.50% Dtd 07/25/2013 Due<br>08/01/2021 Non-Callable          | 115,000.000 | 119,056.05<br>118,422.40                     | 4,025.00<br>1,677.08           | 3.38%            |
| Exxon Mobil Corp Sr Gbl Nt<br>1.902% Dtd 08/16/2019 Due 08/16/2022<br>Callable                            | 20,000.000  | 20,623.40<br>20,640.20                       | 380.00<br>142.65               | 1.84%            |
| Federal Home Loan Bks Cons Bds<br>Step Cpn Dtd 04/27/2017 Due<br>04/27/2022 Callable                      | 50,000.000  | 51,857.50<br>49,887.50                       | 1,150.00<br>204.44             | 2.22%            |



**WBSD - CAPITAL PROJECT RESERVE**

**Account Number:**  
**Statement Period:**

**04/01/20 -**  
**06/30/20**

**Asset Position As of 06/30/20**

| <b>Asset Description</b>  | <b>Units</b> | <b>Market Value<br/>Cost</b> | <b>Est. Annual Income<br/>Accruals</b> | <b>Current<br/>Yield</b> |
|---|--------------|------------------------------|--|--------------------------|
| Federal Farm Cr Bks Cons Systemwide<br>Bds 1.90% Dtd 07/19/2017 Due<br>07/19/2022 Non-Callable  | 60,000.000   | 62,022.00<br>60,145.80       | 1,140.00<br>513.00                     | 1.84%                    |
| Federal Farm Cr Bks Cons Systemwide<br>Bds 1.90% Dtd 08/03/2017 Due<br>08/03/2022 Non-Callable  | 60,000.000   | 62,056.80<br>60,079.80       | 1,140.00<br>468.66                     | 1.84%                    |
| Federal Farm Cr Bks Cons Systemwide<br>Bds 4.75% Dtd 09/21/2005 Due<br>09/21/2020 Non-Callable  | 125,000.000  | 126,413.75<br>127,085.00     | 5,937.00<br>1,649.30                   | 4.70%                    |
| Federal Home Loan Bks Cons Bds<br>2.875% Dtd 08/27/2010 Due 09/11/2020<br>Non-Callable          | 100,000.000  | 100,522.00<br>100,708.00     | 2,875.00<br>878.47                     | 2.86%                    |
| Federal Natl Mtg Assn<br>1.50% Dtd 10/19/2015 Due 11/30/2020<br>Non-Callable                    | 40,000.000   | 40,217.20<br>40,060.40       | 600.00<br>51.66                        | 1.49%                    |
| Federal Natl Mtg Assn<br>1.875% Dtd 11/16/2015 Due 12/28/2020<br>Non-Callable                   | 100,000.000  | 100,830.00<br>100,319.00     | 1,875.00<br>15.62                      | 1.86%                    |
| Federal Natl Mtg Assn<br>1.375% Dtd 02/05/2016 Due 02/26/2021<br>Non-Callable                   | 60,000.000   | 60,445.20<br>59,887.70       | 825.00<br>286.45                       | 1.36%                    |
| Federal Natl Mtg Assn<br>1.375% Dtd 10/07/2016 Due 10/07/2021<br>Non-Callable                   | 60,000.000   | 60,906.60<br>59,745.04       | 825.00<br>192.50                       | 1.35%                    |
| Federal Natl Mtg Assn<br>2.00% Dtd 01/09/2017 Due 01/05/2022<br>Non-Callable                    | 120,000.000  | 123,307.20<br>120,285.60     | 2,400.00<br>1,173.33                   | 1.95%                    |
| Federal Natl Mtg Assn<br>1.875% Dtd 04/10/2017 Due 04/05/2022<br>Non-Callable                   | 60,000.000   | 61,781.40<br>60,102.00       | 1,125.00<br>268.75                     | 1.82%                    |
| Federal Home Ln Mtg Corp<br>2.375% Dtd 01/13/2012 Due 01/13/2022<br>Non-Callable                | 120,000.000  | 124,000.80<br>121,360.80     | 2,850.00<br>1,330.00                   | 2.30%                    |
| Indiana Univ Revs Student Fee Bds V<br>Taxable 2.227% Dtd 10/26/2012 Due<br>08/01/2020 Callable | 25,000.000   | 25,032.25<br>25,070.50       | 556.00<br>231.97                       | 2.22%                    |
| JPMorgan Chase & Co Sr Nt<br>3.25% Dtd 09/24/2012 Due 09/23/2022<br>Non-Callable                | 20,000.000   | 21,119.20<br>21,075.00       | 650.00<br>176.94                       | 3.08%                    |



**WBSD - CAPITAL PROJECT RESERVE**

**Account Number:**  
**Statement Period:**

**04/01/20 -**  
**06/30/20**

**Asset Position As of 06/30/20**

| <b>Asset Description</b>   | <b>Units</b> | <b>Market Value Cost</b> | <b>Est. Annual Income Accruals</b> | <b>Current Yield</b> |
|--|--------------|--------------------------|------------------------------------|----------------------|
| Jackson Cnty MO Reorg Sch Dist GO Sch Bldg Bds 2009c Taxable 4.90% Dtd 11/15/2009 Due 03/01/2021 Callable    | 135,000.000  | 138,204.90<br>138,804.30 | 6,615.00<br>2,205.00               | 4.79%                |
| League City Tex Combi Tax and Rev Cfs O 5.00% Dtd 07/01/2017 Due 02/15/2023 Non-Callable                     | 65,000.000   | 72,514.65<br>71,658.60   | 3,250.00<br>1,227.77               | 4.48%                |
| Massachusetts St GO Bds 2013b 5.00% Dtd 07/02/2013 Due 08/01/2022 Non-Callable                               | 75,000.000   | 82,377.75<br>81,549.75   | 3,750.00<br>1,562.50               | 4.55%                |
| Michigan St GO Ref Bds 2009a Taxable 6.95% Dtd 04/14/2009 Due 11/01/2020 Non-Callable                        | 25,000.000   | 25,509.00<br>25,645.50   | 1,737.00<br>289.58                 | 6.81%                |
| New York St Dorm Auth Revs Non Univ Rev Bds 2019b Taxable 2.839% Dtd 02/21/2019 Due 07/01/2022 Callable      | 100,000.000  | 103,216.00<br>102,432.00 | 2,839.00<br>1,419.50               | 2.75%                |
| New York St Dorm Auth St Pers Income Tax Rev Bds 2010c Taxable 4.554% Dtd 03/11/2010 Due 02/15/2021 Callable | 25,000.000   | 25,431.75<br>25,620.00   | 1,138.00<br>430.10                 | 4.48%                |
| San Francisco Calif City & Cnt Taxable Ref Bds 2019 A Taxable 1.814% Dtd 01/09/2020 Due 11/01/2020 Callable  | 50,000.000   | 50,213.50<br>50,025.00   | 907.00<br>433.34                   | 1.81%                |
| Southwest Tex Indpt Sch Dist Ultd Tax Sch Bldg and RE 5.00% Dtd 07/15/2014 Due 02/01/2022 Non-Callable       | 50,000.000   | 53,678.00<br>53,425.50   | 2,500.00<br>1,041.66               | 4.66%                |
| Statoil Asa Sr Glbl Nt 2.75% Dtd 11/10/2014 Due 11/10/2021 Callable  | 44,000.000   | 45,155.44<br>44,514.36   | 1,210.00<br>171.41                 | 2.68%                |
| Toyota Motor Credit Corp Fr 2.90% Dtd 04/01/2020 Due 03/30/2023 Non-Callable                                 | 20,000.000   | 21,173.00<br>21,078.80   | 580.00<br>144.99                   | 2.74%                |
| US Treasury Note 1.625% Dtd 11/30/2015 Due 11/30/2020  | 30,000.000   | 30,177.00<br>30,008.48   | 487.00<br>41.29                    | 1.62%                |
| US Treasury Note 1.125% Dtd 01/15/2011 Due 01/15/2021 Treasury Inflation Protection Security                 | 46,892.400   | 47,320.53<br>46,639.64   | 527.00<br>245.15                   | 1.11%                |



**WBSD - CAPITAL PROJECT RESERVE**

Account Number:  
 Statement Period:

04/01/20 -  
 06/30/20

**Asset Position As of 06/30/20**

| Asset Description   | Units       | Market Value<br>Cost                             | Est. Annual Income<br>Accruals       | Current<br>Yield |
|---|-------------|--|--------------------------------------|------------------|
| US Treasury Note<br>0.125% Dtd 04/15/2016 Due 04/15/2021<br>Treasury Inflation Protection<br>Security | 32,460.600  | 32,615.11<br>32,381.75                           | 40.00<br>8.59                        | 0.12%            |
| US Treasury Note<br>1.875% Dtd 12/15/2017 Due 12/15/2020  | 30,000.000  | 30,233.70<br>30,157.00                           | 562.00<br>24.59                      | 1.86%            |
| US Treasury Note<br>2.50% Dtd 01/31/2019 Due 01/31/2021   | 100,000.000 | 101,342.00<br>100,833.63                         | 2,500.00<br>1,043.95                 | 2.47%            |
| University Calif Revs Gen Rev Bds<br>2015 A Taxable 2.909% Dtd 03/25/2015<br>Due 05/15/2023 Callable  | 65,000.000  | 68,926.65<br>68,067.35                           | 1,890.00<br>241.60                   | 2.74%            |
| Upper Trinity Regl Wtr Dist Te Rev<br>Ref Bds 3.00% Dtd 01/01/2012 Due<br>08/01/2022 Callable         | 75,000.000  | 77,037.00<br>76,612.50                           | 2,250.00<br>937.50                   | 2.92%            |
| <b>Total Fixed Income</b>   |             | <b>\$ 2,532,593.81</b><br><b>\$ 2,508,145.80</b> | <b>76,012.00</b><br><b>25,523.87</b> | <b>3.00%</b>     |
| <b>Cash</b>   |             |  |                                      |                  |
| Principal Cash  |             | 0.00<br>0.00                                     | 0.00                                 | 0.00%            |
| Income Cash   |             | 0.00<br>0.00                                     | 0.00                                 | 0.00%            |
| <b>Total Cash</b>   |             | <b>\$ 0.00</b><br><b>\$ 0.00</b>                 | <b>0.00</b><br><b>0.00</b>           | <b>0.00%</b>     |
| <b>Total Market Value</b>   |             | <b>\$ 2,756,341.03</b><br><b>\$ 2,731,893.02</b> | <b>76,280.00</b><br><b>25,533.79</b> | <b>2.77%</b>     |
| <b>Total Market Value Plus Accruals</b>   |             | <b>\$ 2,781,874.82</b>                           |                                      |                  |

**Income Activity**

|  | Date     | Income Cash | Principal Cash |
|--|----------|-------------|----------------|
| <b>Interest Income</b>                             |          |             |                |
| Bank of The West Advantage Acct<br>Int To 03/31/20 | 04/01/20 |             | 84.93          |
| Int To 04/30/20                                    | 05/01/20 |             | 192.18         |
| Int To 05/31/20                                    | 06/01/20 |             | 23.37          |



**WBSD - CAPITAL PROJECT RESERVE**

**Account Number:**  
**Statement Period:**

**04/01/20 -**  
**06/30/20**

| Income Activity  |                      |             |                  |
|--|----------------------|-------------|------------------|
|  | Date                 | Income Cash | Principal Cash   |
| Federal Home Loan Bks Cons Bds<br>Step Cpn Dtd 04/27/2017 Due<br>04/27/2022 Callable<br>Int To 04/27/20 on 50,000                  | 04/28/20             |             | 575.00           |
| Federal Farm Cr Bks Cons Systemwide<br>Bds 1.64% Dtd 12/11/2019 Due<br>06/11/2021 Callable<br>Interest At Full Call of             | 04/01/20             |             | 150.33           |
| Federal Home Loan Bks Cons Bds<br>4.625% Dtd 05/25/2005 Due 06/12/2020<br>Non-Callable<br>Int To 06/12/20 on 50,000                | 06/12/20             |             | 1,156.25         |
| Federal Home Ln Mtg Corp<br>1.65% Dtd 04/27/2017 Due 04/27/2020<br>Callable<br>Int To 04/27/20 on 100,000                          | 04/27/20             |             | 825.00           |
| Federal Natl Mtg Assn<br>1.50% Dtd 04/27/2015 Due 06/22/2020<br>Non-Callable<br>Int To 06/22/20 on 40,000                          | 06/22/20             |             | 300.00           |
| Federal Natl Mtg Assn<br>1.50% Dtd 10/19/2015 Due 11/30/2020<br>Non-Callable<br>Int To 05/30/20 on 40,000                          | 06/01/20             |             | 300.00           |
| Federal Natl Mtg Assn<br>1.875% Dtd 11/16/2015 Due 12/28/2020<br>Non-Callable<br>Int To 06/28/20 on 100,000                        | 06/29/20             |             | 937.50           |
| Federal Natl Mtg Assn<br>1.375% Dtd 10/07/2016 Due 10/07/2021<br>Non-Callable<br>Int To 04/07/20 on 60,000                         | 04/07/20             |             | 412.50           |
| Federal Natl Mtg Assn<br>1.875% Dtd 04/10/2017 Due 04/05/2022<br>Non-Callable<br>Int To 04/05/20 on 60,000                         | 04/06/20             |             | 562.50           |
| Federal Natl Mtg Assn<br>1.80% Dtd 10/26/2012 Due 10/26/2021<br>Callable<br>Int To 04/26/20 on 100,000<br>Interest At Full Call of | 04/27/20<br>06/26/20 |             | 900.00<br>300.00 |



**WBSD - CAPITAL PROJECT RESERVE**

Account Number:  
 Statement Period:

04/01/20 -  
 06/30/20

| Income Activity   |          |                |                    |
|---|----------|----------------|--------------------|
|   | Date     | Income Cash    | Principal Cash     |
| Federal Natl Mtg Assn Gtd Passthru<br>CTF Pool #797828 5.000% Dtd<br>04/01/2005 Due 04/01/2020 IPD24<br>Int For March 2020 on 27.93                                 | 04/27/20 |                | 0.12               |
| Michigan St GO Ref Bds 2009a Taxable<br>6.95% Dtd 04/14/2009 Due 11/01/2020<br>Non-Callable<br>Int To 05/01/20 on 25,000  | 05/01/20 |                | 868.75             |
| Statoil Asa Sr Gbl Nt<br>2.75% Dtd 11/10/2014 Due 11/10/2021<br>Callable<br>Int To 05/10/20 on 44,000   | 05/11/20 |                | 605.00             |
| US Treasury Note<br>1.625% Dtd 11/30/2015 Due 11/30/2020<br>Int To 05/31/20 on 30,000   | 06/01/20 |                | 243.75             |
| US Treasury Note<br>0.125% Dtd 04/15/2016 Due 04/15/2021<br>Treasury Inflation Protection<br>Security<br>Int To 04/15/20 on 32695.50                                | 04/15/20 |                | 20.43              |
| US Treasury Note<br>1.875% Dtd 12/15/2017 Due 12/15/2020<br>Int To 06/15/20 on 30,000   | 06/15/20 |                | 281.25             |
| University Calif Revs Gen Rev Bds<br>2015 A Taxable 2.909% Dtd 03/25/2015<br>Due 05/15/2023 Callable<br>Int To 05/15/20 on 65,000                                   | 05/15/20 |                | 945.42             |
| <b>Total Interest Income</b>  |          | <b>\$ 0.00</b> | <b>\$ 9,684.28</b> |
| <b>Purchased Income</b>   |          |                |                    |
| Apple Inc Sr Gbl Nt<br>0.75% Dtd 05/11/2020 Due 05/11/2023<br>Callable<br>Accrued Int To 06/02/20 Paid on<br>Purchase of 10,000                                     | 06/02/20 |                | -4.38              |
| Austin Tex Indpt Sch Dist Ultd Tax<br>Sch Bldg and RE 5.00% Dtd 04/10/2019<br>Due 08/01/2022 Non-Callable<br>Accrued Int To 04/29/20 Paid on<br>Purchase of 100,000 | 04/29/20 |                | -1,222.22          |





**WBSD - CAPITAL PROJECT RESERVE**

Account Number:  
 Statement Period:

04/01/20 -  
 06/30/20

| Income Activity   |          |             |                |
|---|----------|-------------|----------------|
|   | Date     | Income Cash | Principal Cash |
| California St GO Bds<br>5.00% Dtd 03/14/2017 Due 08/01/2023<br>Non-Callable<br>Accrued Int To 05/01/20 Paid on<br>Purchase of 60,000                                      | 05/01/20 |             | -750.00        |
| Citibank NA N Y<br>2.85% Dtd 02/15/2018 Due 02/12/2021<br>Callable<br>Accrued Int To 04/15/20 Paid on<br>Purchase of 32,000   | 04/15/20 |             | -159.60        |
| Credit Suisse Ag New York Bran Fr<br>2.80% Dtd 04/09/2020 Due 04/08/2022<br>Non-Callable<br>Accrued Int To 05/29/20 Paid on<br>Purchase of 20,000                         | 05/29/20 |             | -77.78         |
| Disney Walt Co Sr Gbl Nt<br>1.65% Dtd 09/06/2019 Due 09/01/2022<br>Callable<br>Accrued Int To 05/29/20 Paid on<br>Purchase of 20,000                                      | 05/29/20 |             | -80.67         |
| East Side Un High Sch Dist Cal GO<br>Ref Bds 3.50% Dtd 07/25/2013 Due<br>08/01/2021 Non-Callable<br>Accrued Int To 04/30/20 Paid on<br>Purchase of 115,000                | 04/30/20 |             | -995.07        |
| Exxon Mobil Corp Sr Gbl Nt<br>1.902% Dtd 08/16/2019 Due 08/16/2022<br>Callable<br>Accrued Int To 06/02/20 Paid on<br>Purchase of 20,000                                   | 06/02/20 |             | -112.01        |
| JPMorgan Chase & Co Sr Nt<br>3.25% Dtd 09/24/2012 Due 09/23/2022<br>Non-Callable<br>Accrued Int To 05/29/20 Paid on<br>Purchase of 20,000                                 | 05/29/20 |             | -119.17        |
| Jackson Cnty MO Reorg Sch Dist GO<br>Sch Bldg Bds 2009c Taxable 4.90% Dtd<br>11/15/2009 Due 03/01/2021 Callable<br>Accrued Int To 04/17/20 Paid on<br>Purchase of 135,000 | 04/17/20 |             | -845.25        |



**WBSD - CAPITAL PROJECT RESERVE**

Account Number:  
 Statement Period:

04/01/20 -  
 06/30/20

| Income Activity  |          |             |                |
|--|----------|-------------|----------------|
|  | Date     | Income Cash | Principal Cash |
| League City Tex Combi Tax and Rev<br>Cffs O 5.00% Dtd 07/01/2017 Due<br>02/15/2023 Non-Callable<br>Accrued Int To 05/01/20 Paid on<br>Purchase of 65,000                 | 05/01/20 |             | -686.11        |
| Massachusetts St GO Bds 2013b<br>5.00% Dtd 07/02/2013 Due 08/01/2022<br>Non-Callable<br>Accrued Int To 04/29/20 Paid on<br>Purchase of 75,000                            | 04/29/20 |             | -916.67        |
| New York St Dorm Auth Revs Non Univ<br>Rev Bds 2019b Taxable 2.839% Dtd<br>02/21/2019 Due 07/01/2022 Callable<br>Accrued Int To 04/17/20 Paid on<br>Purchase of 100,000  | 04/17/20 |             | -835.93        |
| Southwest Tex Indpt Sch Dist Ultd<br>Tax Sch Bldg and RE 5.00% Dtd<br>07/15/2014 Due 02/01/2022<br>Non-Callable<br>Accrued Int To 04/29/20 Paid on<br>Purchase of 50,000 | 04/29/20 |             | -611.11        |
| Statoil Asa Sr Gbl Nt<br>2.75% Dtd 11/10/2014 Due 11/10/2021<br>Callable<br>Accrued Int To 04/13/20 Paid on<br>Purchase of 44,000  | 04/13/20 |             | -514.25        |
| Toyota Motor Credit Corp Fr<br>2.90% Dtd 04/01/2020 Due 03/30/2023<br>Non-Callable<br>Accrued Int To 05/29/20 Paid on<br>Purchase of 20,000                              | 05/29/20 |             | -93.44         |
| US Treasury Note<br>1.125% Dtd 01/15/2011 Due 01/15/2021<br>Treasury Inflation Protection<br>Security<br>Accrued Int To 04/15/20 Paid on<br>Purchase of 47,231.600       | 04/15/20 |             | -132.84        |
| University Calif Revs Gen Rev Bds<br>2015 A Taxable 2.909% Dtd 03/25/2015<br>Due 05/15/2023 Callable<br>Accrued Int To 05/01/20 Paid on<br>Purchase of 65,000            | 05/01/20 |             | -871.89        |



**WBSD - CAPITAL PROJECT RESERVE**

Account Number:  
 Statement Period:

04/01/20 -  
 06/30/20

| Income Activity  |          |                |                     |
|--|----------|----------------|---------------------|
|  | Date     | Income Cash    | Principal Cash      |
| Upper Trinity Regl Wtr Dist Te Rev<br>Ref Bds 3.00% Dtd 01/01/2012 Due<br>08/01/2022 Callable<br>Accrued Int To 04/20/20 Paid on<br>Purchase of 75,000 | 04/20/20 |                | -493.75             |
| <b>Total Purchased Income</b>  |          | <b>\$ 0.00</b> | <b>\$ -9,522.14</b> |
| <b>Total Income</b>  |          | <b>\$ 0.00</b> | <b>\$ 162.14</b>    |

| Additions   |          |                |                      |
|---|----------|----------------|----------------------|
|   | Date     | Income Cash    | Principal Cash       |
| <b>Miscellaneous Additions</b>  |          |                |                      |
| Addition To Account<br>ACH Transfer From Bank of The West<br>Ckg Ending In 6049 Per<br>Instruction 4/8/20 | 04/10/20 |                | 683,000.00           |
| <b>Total Miscellaneous Additions</b>  |          | <b>\$ 0.00</b> | <b>\$ 683,000.00</b> |
| <b>Total Additions</b>  |          | <b>\$ 0.00</b> | <b>\$ 683,000.00</b> |

| Disbursement Activity      |          |                |                     |
|----------------------------|----------|----------------|---------------------|
|                            | Date     | Income Cash    | Principal Cash      |
| <b>Fees/Expenses</b>       |          |                |                     |
| Monthly Fee To 03/31/20    | 04/15/20 |                | -364.35             |
| Monthly Fee To 04/30/20    | 05/15/20 |                | -467.62             |
| Monthly Fee To 05/31/20    | 06/15/20 |                | -468.60             |
| <b>Total Fees/Expenses</b> |          | <b>\$ 0.00</b> | <b>\$ -1,300.57</b> |
| <b>Total Disbursements</b> |          | <b>\$ 0.00</b> | <b>\$ -1,300.57</b> |



**WBSD - CAPITAL PROJECT RESERVE**

Account Number:  
 Statement Period:

04/01/20 -  
 06/30/20

| Purchase Activity  |          |                |
|--|----------|----------------|
|  | Date     | Principal Cash |
| Bank of The West Advantage Acct<br>Purchases (14) 04/01/20 To 06/30/20   | 06/30/20 | -1,011,630.85  |
| Apple Inc Sr Gbl Nt<br>0.75% Dtd 05/11/2020 Due 05/11/2023<br>Callable<br>Purchased 10000 05/29/20<br>From BNY Mellon/Toronto Dominion Sec<br>@ 101.187                          | 06/02/20 | -10,118.70     |
| Austin Tex Indpt Sch Dist Ultd Tax<br>Sch Bldg and RE 5.00% Dtd 04/10/2019<br>Due 08/01/2022 Non-Callable<br>Purchased 100000 04/27/20<br>From Samco Capital Markets<br>@ 108.78 | 04/29/20 | -108,780.00    |
| California St GO Bds<br>5.00% Dtd 03/14/2017 Due 08/01/2023<br>Non-Callable<br>Purchased 60000 04/29/20<br>From Southwest Securities<br>@ 111.059                                | 05/01/20 | -66,635.40     |
| Citibank NA N Y<br>2.85% Dtd 02/15/2018 Due 02/12/2021<br>Callable<br>Purchased 32000 04/13/20<br>From BNY Mellon/Toronto Dominion Sec<br>@ 100.83                               | 04/15/20 | -32,265.60     |
| Collin Cnty Tex Cmnty College GO Bds<br>2020a 5.00% Dtd 03/15/2020 Due<br>08/15/2021 Non-Callable<br>Purchased 100000 04/27/20<br>From Mesirow Financial Inc<br>@ 104.864        | 04/29/20 | -104,864.00    |
| Credit Suisse Ag New York Bran Fr<br>2.80% Dtd 04/09/2020 Due 04/08/2022<br>Non-Callable<br>Purchased 20000 05/27/20<br>From BNY Mellon/Toronto Dominion Sec<br>@ 103.644        | 05/29/20 | -20,728.80     |
| Disney Walt Co Sr Gbl Nt<br>1.65% Dtd 09/06/2019 Due 09/01/2022<br>Callable<br>Purchased 20000 05/27/20<br>From BNY Mellon/Toronto Dominion Sec<br>@ 102.122                     | 05/29/20 | -20,424.40     |



**WBSD - CAPITAL PROJECT RESERVE**

Account Number:  
 Statement Period:

04/01/20 -  
 06/30/20

| Purchase Activity  |          |             |                |
|--|----------|-------------|----------------|
|  | Date     | Income Cash | Principal Cash |
| East Side Un High Sch Dist Cal GO<br>Ref Bds 3.50% Dtd 07/25/2013 Due<br>08/01/2021 Non-Callable<br>Purchased 115000 04/28/20<br>From Stifel Nicolaus & Co<br>@ 102.976                | 04/30/20 |             | -118,422.40    |
| Exxon Mobil Corp Sr Glbl Nt<br>1.902% Dtd 08/16/2019 Due 08/16/2022<br>Callable<br>Purchased 20000 05/29/20<br>From BNY Mellon/Toronto Dominion Sec<br>@ 103.201                       | 06/02/20 |             | -20,640.20     |
| JPMorgan Chase & Co Sr Nt<br>3.25% Dtd 09/24/2012 Due 09/23/2022<br>Non-Callable<br>Purchased 20000 05/27/20<br>From BNY Mellon/Toronto Dominion Sec<br>@ 105.375                      | 05/29/20 |             | -21,075.00     |
| Jackson Cnty MO Reorg Sch Dist GO<br>Sch Bldg Bds 2009c Taxable 4.90% Dtd<br>11/15/2009 Due 03/01/2021 Callable<br>Purchased 135000 04/15/20<br>From Wedbush Morgan Secs<br>@ 102.818  | 04/17/20 |             | -138,804.30    |
| League City Tex Combi Tax and Rev<br>Ctfs O 5.00% Dtd 07/01/2017 Due<br>02/15/2023 Non-Callable<br>Purchased 65000 04/29/20<br>From BOK Financial Securities, Inc.<br>@ 110.244        | 05/01/20 |             | -71,658.60     |
| Massachusetts St GO Bds 2013b<br>5.00% Dtd 07/02/2013 Due 08/01/2022<br>Non-Callable<br>Purchased 75000 04/27/20<br>From Tmc Bonds LLC<br>@ 108.733                                    | 04/29/20 |             | -81,549.75     |
| New York St Dorm Auth Revs Non Univ<br>Rev Bds 2019b Taxable 2.839% Dtd<br>02/21/2019 Due 07/01/2022 Callable<br>Purchased 100000 04/15/20<br>From Headlands Holdings LLC<br>@ 102.432 | 04/17/20 |             | -102,432.00    |



**WBSD - CAPITAL PROJECT RESERVE**

Account Number:  
 Statement Period:

04/01/20 -  
 06/30/20

| Purchase Activity  |          |                |                         |
|--|----------|----------------|-------------------------|
|  | Date     | Income Cash    | Principal Cash          |
| Southwest Tex Indpt Sch Dist Ultl<br>Tax Sch Bldg and RE 5.00% Dtd<br>07/15/2014 Due 02/01/2022<br>Non-Callable<br>Purchased 50000 04/27/20<br>From Samco Capital Markets<br>@ 106.851   | 04/29/20 |                | -53,425.50              |
| Statoil Asa Sr Gbl Nt<br>2.75% Dtd 11/10/2014 Due 11/10/2021<br>Callable<br>Purchased 44000 04/08/20<br>From BNY Mellon/Toronto Dominion Sec<br>@ 101.225                                | 04/13/20 |                | -44,539.00              |
| Toyota Motor Credit Corp Fr<br>2.90% Dtd 04/01/2020 Due 03/30/2023<br>Non-Callable<br>Purchased 20000 05/27/20<br>From BNY Mellon/Toronto Dominion Sec<br>@ 105.394                      | 05/29/20 |                | -21,078.80              |
| US Treasury Note<br>1.125% Dtd 01/15/2011 Due 01/15/2021<br>Treasury Inflation Protection<br>Security<br>Purchased 47231.600 04/14/20<br>From Wells Fargo Securities, LLC<br>@ 99.464844 | 04/15/20 |                | -46,978.84              |
| University Calif Revs Gen Rev Bds<br>2015 A Taxable 2.909% Dtd 03/25/2015<br>Due 05/15/2023 Callable<br>Purchased 65000 04/29/20<br>From Wells Fargo Securities, LLC<br>@ 104.778        | 05/01/20 |                | -68,105.70              |
| Upper Trinity Regl Wtr Dist Te Rev<br>Ref Bds 3.00% Dtd 01/01/2012 Due<br>08/01/2022 Callable<br>Purchased 75000 04/16/20<br>From Stifel Nicolaus & Co<br>@ 102.15                       | 04/20/20 |                | -76,612.50              |
| <b>Total Purchases</b>   |          | <b>\$ 0.00</b> | <b>\$ -2,240,770.34</b> |



**WBSD - CAPITAL PROJECT RESERVE**

**Account Number:**  
**Statement Period:**

**04/01/20 -**  
**06/30/20**

| <b>Sale Activity</b>  |             |                        |                           |
|---|-------------|------------------------|---------------------------|
|   | <b>Date</b> | <b>Proceeds</b>        | <b>Realized Gain/Loss</b> |
| Bank of The West Advantage Acct<br>Sales (12) 04/01/20 To 06/30/20  | 06/30/20    | 1,238,880.84           |                           |
| Federal Farm Cr Bks Cons Systemwide<br>Bds 1.64% Dtd 12/11/2019 Due<br>06/11/2021 Callable<br>Recd Proceeds on Full Call of<br>30,000 Par Value | 04/01/20    | 30,000.00              |                           |
| Federal Home Loan Bks Cons Bds<br>4.625% Dtd 05/25/2005 Due 06/12/2020<br>Non-Callable<br>Recd Proceeds on Maturity of<br>50,000 Par Value      | 06/12/20    | 50,000.00              |                           |
| Federal Home Ln Mtg Corp<br>1.65% Dtd 04/27/2017 Due 04/27/2020<br>Callable<br>Recd Proceeds on Maturity of<br>100,000 Par Value                | 04/27/20    | 100,000.00             |                           |
| Federal Natl Mtg Assn<br>1.50% Dtd 04/27/2015 Due 06/22/2020<br>Non-Callable<br>Recd Proceeds on Maturity of<br>40,000 Par Value                | 06/22/20    | 40,000.00              |                           |
| Federal Natl Mtg Assn<br>1.80% Dtd 10/26/2012 Due 10/26/2021<br>Callable<br>Recd Proceeds on Full Call of<br>100,000 Par Value                  | 06/26/20    | 100,000.00             |                           |
| Federal Natl Mtg Assn Gtd Passthru<br>CTF Pool #797828 5.000% Dtd<br>04/01/2005 Due 04/01/2020 IPD24<br>Recd Proceeds At Final Paydown of       | 04/27/20    | 27.93                  | -1.55                     |
| <b>Total Sales</b>  |             | <b>\$ 1,558,908.77</b> | <b>\$ -1.55</b>           |

| <b>Non-Cash Activity</b>  |             |             |
|---|-------------|-------------|
|   | <b>Date</b> | <b>Cost</b> |
| Federal Home Loan Bks Cons Bds<br>4.625% Dtd 05/25/2005 Due 06/12/2020<br>Non-Callable<br>Amortization of Premium | 06/12/20    | -761.50     |



**WBSD - CAPITAL PROJECT RESERVE**

Account Number:  
 Statement Period:

04/01/20 -  
 06/30/20

| Non-Cash Activity  |          |         |
|--|----------|---------|
|  | Date     | Cost    |
| Federal Home Ln Mtg Corp<br>1.65% Dtd 04/27/2017 Due 04/27/2020<br>Callable<br>Accretion of Discount                   | 04/27/20 | 72.02   |
| Federal Natl Mtg Assn<br>1.50% Dtd 04/27/2015 Due 06/22/2020<br>Non-Callable<br>Amortization of Premium                | 06/22/20 | -84.80  |
| Federal Natl Mtg Assn<br>1.50% Dtd 10/19/2015 Due 11/30/2020<br>Non-Callable<br>Amortization of Premium                | 05/29/20 | -60.00  |
| Federal Natl Mtg Assn<br>1.875% Dtd 11/16/2015 Due 12/28/2020<br>Non-Callable<br>Amortization of Premium               | 06/26/20 | -318.00 |
| Federal Natl Mtg Assn<br>1.375% Dtd 02/05/2016 Due 02/26/2021<br>Non-Callable<br>Accretion of Discount                 | 04/30/20 | 14.25   |
| Accretion of Discount  | 05/29/20 | 14.25   |
| Accretion of Discount  | 06/30/20 | 14.25   |
| Federal Natl Mtg Assn<br>1.375% Dtd 10/07/2016 Due 10/07/2021<br>Non-Callable<br>Accretion of Discount                 | 04/30/20 | 16.71   |
| Accretion of Discount  | 05/29/20 | 16.71   |
| Accretion of Discount  | 06/30/20 | 16.71   |
| Federal Natl Mtg Assn<br>1.875% Dtd 04/10/2017 Due 04/05/2022<br>Non-Callable<br>Amortization of Premium               | 04/03/20 | -24.60  |
| Michigan St GO Ref Bds 2009a Taxable<br>6.95% Dtd 04/14/2009 Due 11/01/2020<br>Non-Callable<br>Amortization of Premium | 05/01/20 | -408.75 |
| Statoil Asa Sr Glbl Nt<br>2.75% Dtd 11/10/2014 Due 11/10/2021<br>Callable<br>Amortization of Premium                   | 05/08/20 | -24.64  |
| US Treasury Note<br>1.625% Dtd 11/30/2015 Due 11/30/2020<br>Amortization of Premium                                    | 05/29/20 | -5.58   |





**WBSD - CAPITAL PROJECT RESERVE**

Account Number:  
 Statement Period:

04/01/20 -  
 06/30/20

**Non-Cash Activity**

|   | Date     | Cost                |
|---|----------|---------------------|
| US Treasury Note<br>1.125% Dtd 01/15/2011 Due 01/15/2021<br>Treasury Inflation Protection<br>Security                           |          |                     |
| Inflationary Int Adjustment 04/29/20  | 04/29/20 | 64.80               |
| Inflationary Int Adjustment 05/14/20  | 05/14/20 | -42.40              |
| Inflationary Int Adjustment 05/28/20  | 05/28/20 | -53.20              |
| Inflationary Int Adjustment 06/12/20  | 06/12/20 | -150.40             |
| Inflationary Int Adjustment 06/30/20  | 06/30/20 | -158.00             |
| US Treasury Note<br>0.125% Dtd 04/15/2016 Due 04/15/2021<br>Treasury Inflation Protection<br>Security                           |          |                     |
| Inflationary Int Adjustment 04/14/20  | 04/14/20 | 45.90               |
| Inflationary Int Adjustment 04/29/20  | 04/29/20 | 44.70               |
| Inflationary Int Adjustment 05/14/20  | 05/14/20 | -29.40              |
| Inflationary Int Adjustment 05/28/20  | 05/28/20 | -36.60              |
| Inflationary Int Adjustment 06/12/20  | 06/12/20 | -104.40             |
| Inflationary Int Adjustment 06/30/20  | 06/30/20 | -109.20             |
| US Treasury Note<br>1.875% Dtd 12/15/2017 Due 12/15/2020<br>Amortization of Premium   | 06/15/20 | -87.92              |
| University Calif Revs Gen Rev Bds<br>2015 A Taxable 2.909% Dtd 03/25/2015<br>Due 05/15/2023 Callable<br>Amortization of Premium | 05/15/20 | -38.35              |
| <b>Total Non-Cash Transactions</b>  |          | <b>\$ -2,177.44</b> |

SECURITY PRICES CONTAINED IN THIS STATEMENT ARE OBTAINED FROM THE MOST RELIABLE SOURCES AVAILABLE BUT ARE NOT GUARANTEED BY BANK OF THE WEST. QUOTED PRICES MAY NOT EQUAL ACTUAL PRICES BECAUSE OF SECURITY SIZE, MARKET PRICE, TERM AND DEMAND.



## **Electronic Funds Transfers**

### Preauthorized Transfers:

You may request an electronic fund transfer (EFT), such as an ACH transfer from or deposit to your account, by contacting your account Administrator. You may also preauthorize periodic EFTs by contacting your account Administrator. If you would like to know whether a preauthorized EFT has occurred, please contact your account Administrator at the phone number listed on the first page of your statement, or call 1-877-898-1003 (TTY 1-800-659-5495) between the hours of 8:00 A.M. to 5:00 P.M. Pacific Standard Time.

### Error Resolution Notice:

If you think a statement or receipt is wrong or if you need more information about an EFT listed on a statement or receipt, telephone us at 1-877-898-1003 (TTY 1-800-659-5495) between the hours of 8:00 A.M. to 5:00 P.M. Pacific Standard Time, write to us at Bank of the West, 13300 Crossroads Parkway North, City of Industry, CA 91746, or e-mail us at [WMGIFSOperations@bankofthewest.com](mailto:WMGIFSOperations@bankofthewest.com) as soon as possible. We must hear from you no later than 60 days after we sent the FIRST statement on which the problem or error appeared.

1. Tell us your name and account number (if any).
2. Tell us the dollar amount of the suspected error.
3. Describe the error or the transfer you are unsure about, and explain as clearly as you can why you believe it is an error or why you need more information.

If you contact us verbally, we may require that you send us your complaint or question in writing within 10 business days. We will investigate your complaint and will correct any error promptly. If we take more than 10 business days to do this, we will credit your account for the amount you think is in error, so that you will have the use of the money during the time it takes us to complete our investigation.



**WBSD - EMERGENCY CAPITAL RESERVE**

Account Number:  
 Statement Period:

04/01/20 -  
 06/30/20

WEST BAY SANITARY DISTRICT  
 ATTN: PHILLIP L. SCOTT  
 500 LAUREL STREET  
 MENLO PARK CA 94025

**Fiduciary**  
 Chuen Ying Lee  
 (408) 645-3234  
**Portfolio**  
 Michael D. Smith  
 (408) 490-2079

**Asset Allocation**

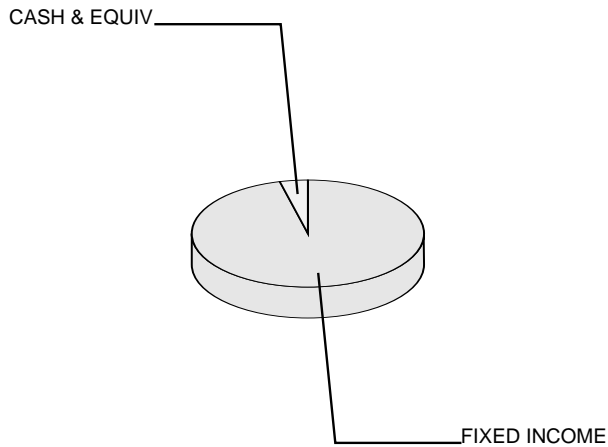

**Asset Valuation**

| Description            | Market Value           | % of Account  |
|------------------------|------------------------|---------------|
| Cash & Equiv           | 146,538.48             | 3.8%          |
| Fixed Income           | 3,732,807.79           | 96.2%         |
| <b>Total Portfolio</b> | <b>\$ 3,879,346.27</b> | <b>100.0%</b> |
| Accrued Income         | 25,356.22              |               |
| <b>Total Valuation</b> | <b>\$ 3,904,702.49</b> |               |

**Market Reconciliation**

|   | Current Period         | Year To Date           |
|---|------------------------|------------------------|
| <b>Beginning Market Value</b>                     | <b>\$ 3,685,182.28</b> | <b>\$ 4,308,686.39</b> |
| Income  |                        |                        |
| Interest.....                                     | 17,598.87              | 93,444.71              |
| Purchased Income.....                             | -7,503.80              | -12,041.20             |
| Additions.....                                    | 200,000.00             | 200,000.00             |
| Disbursements.....                                | -1,963.32              | -1,703,465.88          |
| Cash Transfers.....                               | 0.00                   | 8,700.00               |
| Realized Gains/(Losses).....                      | 5,207.93               | -19,339.38             |
| Change In Accrued Income.....                     | 9,205.09               | 546.86                 |
| Change In Market Appreciation/(Depreciation)..... | -1,997.01              | 47,585.97              |
| Non-Cash Asset Changes.....                       | -1,027.55              | 980,585.02             |
| <b>Ending Market Value</b>                        | <b>\$ 3,904,702.49</b> | <b>\$ 3,904,702.49</b> |



**WBSD - EMERGENCY CAPITAL RESERVE**

Account Number:  
Statement Period:

04/01/20 -  
06/30/20

**Asset Position As of 06/30/20**

| Asset Description  | Units       | Market Value<br>Cost                         | Est. Annual Income<br>Accruals | Current<br>Yield |
|--|-------------|--|--------------------------------|------------------|
| <b>Cash Equivalents</b>  |             |  |                                |                  |
| Bank of The West Advantage Acct  | 146,538.480 | 146,538.48<br>146,538.48                     | 175.00<br>28.81                | 0.12%            |
| <b>Total Cash Equivalents</b>  |             | <b>\$ 146,538.48</b><br><b>\$ 146,538.48</b> | <b>175.00</b><br><b>28.81</b>  | <b>0.12%</b>     |
| <b>Fixed Income</b>  |             |  |                                |                  |
| American Express Co Sr Gbl<br>2.50% Dtd 07/30/2019 Due 07/30/2024<br>Callable                      | 100,000.000 | 105,843.00<br>105,752.00                     | 2,500.00<br>1,048.61           | 2.36%            |
| Apple Inc Sr Gbl Nt<br>0.75% Dtd 05/11/2020 Due 05/11/2023<br>Callable                             | 25,000.000  | 25,263.50<br>25,296.75                       | 187.00<br>26.04                | 0.74%            |
| Autozone Inc Sr Gbl<br>2.50% Dtd 04/29/2015 Due 04/15/2021<br>Callable                             | 45,000.000  | 45,627.30<br>45,603.90                       | 1,125.00<br>237.50             | 2.47%            |
| Credit Suisse Ag New York Bran Fr<br>2.80% Dtd 04/09/2020 Due 04/08/2022<br>Non-Callable           | 45,000.000  | 46,686.15<br>46,639.80                       | 1,260.00<br>287.00             | 2.70%            |
| Disney Walt Co Sr Gbl Nt<br>1.65% Dtd 09/06/2019 Due 09/01/2022<br>Callable                        | 45,000.000  | 46,047.60<br>45,954.90                       | 742.00<br>247.50               | 1.61%            |
| Exxon Mobil Corp Sr Gbl Nt<br>1.902% Dtd 08/16/2019 Due 08/16/2022<br>Callable                     | 45,000.000  | 46,402.65<br>46,440.45                       | 855.00<br>320.95               | 1.84%            |
| Federal Home Ln Mtg Corp Partn Gold<br>Group #G11940 5.500% Dtd 03/01/2006<br>Due 05/01/2020 IPD14 |             | 0.00<br>0.00                                 | 0.00<br>0.09                   | 0.00%            |
| Federal Home Loan Bks Cons Bds<br>Step Cpn Dtd 04/27/2017 Due<br>04/27/2022 Callable               | 120,000.000 | 124,458.00<br>119,730.00                     | 2,760.00<br>490.66             | 2.22%            |
| Federal Farm Cr Bks Cons Systemwide<br>Bds 1.90% Dtd 08/03/2017 Due<br>08/03/2022 Non-Callable     | 80,000.000  | 82,742.40<br>80,106.40                       | 1,520.00<br>624.88             | 1.84%            |
| Federal Home Loan Bks Cons Bds<br>2.875% Dtd 08/27/2010 Due 09/11/2020<br>Non-Callable             | 80,000.000  | 80,417.60<br>80,566.40                       | 2,300.00<br>702.77             | 2.86%            |



**WBSD - EMERGENCY CAPITAL RESERVE**

**Account Number:**  
**Statement Period:**

**04/01/20 -**  
**06/30/20**

**Asset Position As of 06/30/20**

| <b>Asset Description</b>  | <b>Units</b> | <b>Market Value<br/>Cost</b> | <b>Est. Annual Income<br/>Accruals</b> | <b>Current<br/>Yield</b> |
|---|--------------|------------------------------|--|--------------------------|
| Federal Home Loan Bks Cons Bds<br>3.125% Dtd 11/17/2010 Due 12/11/2020<br>Non-Callable          | 110,000.000  | 111,461.90<br>111,474.66     | 3,437.00<br>190.97                     | 3.08%                    |
| Federal Home Ln Mtg Corp Medium<br>Term Nts 1.625% Dtd 04/27/2017 Due<br>07/27/2020 Callable    | 40,000.000   | 40,040.00<br>40,000.00       | 650.00<br>115.55                       | 1.62%                    |
| Federal Natl Mtg Assn<br>1.50% Dtd 10/19/2015 Due 11/30/2020<br>Non-Callable                    | 275,000.000  | 276,493.25<br>274,555.25     | 4,125.00<br>355.20                     | 1.49%                    |
| Federal Natl Mtg Assn<br>1.875% Dtd 11/16/2015 Due 12/28/2020<br>Non-Callable                   | 40,000.000   | 40,332.00<br>40,127.60       | 750.00<br>6.24                         | 1.86%                    |
| Federal Natl Mtg Assn<br>1.375% Dtd 02/05/2016 Due 02/26/2021<br>Non-Callable                   | 60,000.000   | 60,445.20<br>59,887.70       | 825.00<br>286.45                       | 1.36%                    |
| Federal Natl Mtg Assn<br>1.25% Dtd 08/19/2016 Due 08/17/2021<br>Non-Callable                    | 130,000.000  | 131,565.20<br>129,088.85     | 1,625.00<br>604.86                     | 1.24%                    |
| Federal Natl Mtg Assn<br>1.375% Dtd 10/07/2016 Due 10/07/2021<br>Non-Callable                   | 60,000.000   | 60,906.60<br>59,745.04       | 825.00<br>192.50                       | 1.35%                    |
| Federal Natl Mtg Assn<br>2.00% Dtd 01/09/2017 Due 01/05/2022<br>Non-Callable                    | 60,000.000   | 61,653.60<br>60,142.80       | 1,200.00<br>586.66                     | 1.95%                    |
| Federal Natl Mtg Assn<br>1.75% Dtd 09/28/2017 Due 09/28/2020<br>Callable                        | 130,000.000  | 130,504.40<br>130,000.00     | 2,275.00<br>587.70                     | 1.74%                    |
| Federal Home Ln Mtg Corp<br>2.375% Dtd 01/13/2012 Due 01/13/2022<br>Non-Callable                | 60,000.000   | 62,000.40<br>60,680.40       | 1,425.00<br>664.99                     | 2.30%                    |
| Harley Davidson Finl Svcs Inc Fr<br>2.55% Dtd 06/09/2017 Due 06/09/2022<br>Callable             | 100,000.000  | 100,357.00<br>100,650.00     | 2,550.00<br>155.83                     | 2.54%                    |
| Home Depot Inc Sr Gbl Nt<br>2.00% Dtd 02/12/2016 Due 04/01/2021<br>Callable                     | 60,000.000   | 60,712.20<br>59,878.80       | 1,200.00<br>299.99                     | 1.98%                    |
| Indiana Univ Revs Student Fee Bds V<br>Taxable 2.227% Dtd 10/26/2012 Due<br>08/01/2020 Callable | 25,000.000   | 25,032.25<br>25,070.50       | 556.00<br>231.97                       | 2.22%                    |



**WBSD - EMERGENCY CAPITAL RESERVE**

**Account Number:**  
**Statement Period:**

**04/01/20 -**  
**06/30/20**

**Asset Position As of 06/30/20**

| <b>Asset Description</b>  | <b>Units</b> | <b>Market Value Cost</b> | <b>Est. Annual Income Accruals</b> | <b>Current Yield</b> |
|---|--------------|--------------------------|------------------------------------|----------------------|
| JPMorgan Chase & Co Sr Nt<br>3.25% Dtd 09/24/2012 Due 09/23/2022<br>Non-Callable  | 45,000.000   | 47,518.20<br>47,418.75   | 1,462.00<br>398.13                 | 3.08%                |
| Jackson Cnty MO Reorg Sch Dist GO<br>Sch Bldg Bds 2009c Taxable 4.90% Dtd<br>11/15/2009 Due 03/01/2021 Callable                   | 100,000.000  | 102,374.00<br>102,818.00 | 4,900.00<br>1,633.33               | 4.79%                |
| Lawrence Kans GO Impt Bds 2017 D<br>5.00% Dtd 09/28/2017 Due 09/01/2021<br>Non-Callable   | 70,000.000   | 73,861.90<br>73,432.10   | 3,500.00<br>1,166.66               | 4.74%                |
| Michigan St GO Ref Bds 2009a Taxable<br>6.95% Dtd 04/14/2009 Due 11/01/2020<br>Non-Callable                                       | 25,000.000   | 25,509.00<br>25,645.50   | 1,737.00<br>289.58                 | 6.81%                |
| Mississippi St Univ Edl Bldg C Rev<br>Bds 4.00% Dtd 05/17/2017 Due<br>08/01/2021 Non-Callable                                     | 60,000.000   | 62,419.80<br>62,006.40   | 2,400.00<br>1,000.00               | 3.84%                |
| Morgan Stanley Fr<br>5.75% Dtd 01/25/2011 Due 01/25/2021<br>Callable  | 45,000.000   | 46,343.70<br>46,528.20   | 2,587.00<br>1,121.25               | 5.58%                |
| New Hampshire Health & Ed Facs<br>Taxable Univ Sys Issue B 2017 B<br>Taxable 2.292% Dtd 12/06/2017 Due<br>07/01/2021 Non-Callable | 25,000.000   | 25,205.00<br>25,158.75   | 573.00<br>286.50                   | 2.27%                |
| New York N Y GO Bds Subser Taxable<br>4.669% Dtd 10/15/2009 Due 10/01/2022<br>Callable  | 45,000.000   | 48,807.00<br>47,869.65   | 2,101.00<br>525.26                 | 4.30%                |
| New York St Dorm Auth Revs Non Univ<br>Rev Bds 2019b Taxable 2.839% Dtd<br>02/21/2019 Due 07/01/2022 Callable                     | 100,000.000  | 103,216.00<br>102,432.00 | 2,839.00<br>1,419.50               | 2.75%                |
| Pfizer Inc Sr Nt<br>5.20% Dtd 08/12/2015 Due 08/12/2020<br>Non-Callable   | 100,000.000  | 100,547.00<br>101,605.00 | 5,200.00<br>2,007.77               | 5.17%                |
| San Diego Tex Indpt Sch Dist Unltd<br>Tax Ref Bds 3.00% Dtd 05/15/2020 Due<br>08/15/2022 Non-Callable                             | 100,000.000  | 105,051.00<br>103,953.00 | 3,000.00<br>333.33                 | 2.86%                |
| San Francisco Calif City & Cnt<br>Taxable Ref Bds 2019 A Taxable<br>1.814% Dtd 01/09/2020 Due 11/01/2020<br>Callable              | 50,000.000   | 50,213.50<br>50,025.00   | 907.00<br>433.34                   | 1.81%                |



**WBSD - EMERGENCY CAPITAL RESERVE**

**Account Number:**  
**Statement Period:**

**61-J004-01-2**  
**04/01/20 - 06/30/20**

**Asset Position As of 06/30/20**

| <b>Asset Description</b>  | <b>Units</b> | <b>Market Value<br/>Cost</b> | <b>Est. Annual Income<br/>Accruals</b> | <b>Current<br/>Yield</b> |
|---|--------------|------------------------------|--|--------------------------|
| Small Business Admin Gtd Ln Pool<br>Cfs 4.34% Dtd 03/17/2004 Due<br>03/01/2024                        | 8,094.590    | 8,416.11<br>12,760.73        | 351.00<br>148.57                       | 4.17%                    |
| Small Business Admin Gtd Ln Pool<br>Cfs 4.084% Dtd 03/29/2011 Due<br>03/10/2021                       | 4,194.560    | 4,266.75<br>5,009.20         | 171.00<br>84.00                        | 4.01%                    |
| Starbucks Corp Sr Gbl<br>2.10% Dtd 02/04/2016 Due 02/04/2021<br>Callable                              | 60,000.000   | 60,495.60<br>59,984.40       | 1,260.00<br>514.50                     | 2.08%                    |
| 3M Co Fr<br>2.00% Dtd 06/26/2012 Due 06/26/2022<br>Non-Callable                                       | 100,000.000  | 103,145.00<br>99,468.24      | 2,000.00<br>27.77                      | 1.94%                    |
| Toyota Motor Credit Corp Fr<br>2.90% Dtd 04/01/2020 Due 03/30/2023<br>Non-Callable                    | 50,000.000   | 52,932.50<br>52,697.00       | 1,450.00<br>362.49                     | 2.74%                    |
| Toyota Motor Credit Corp Fr<br>3.00% Dtd 04/01/2020 Due 04/01/2025<br>Callable                        | 40,000.000   | 43,473.20<br>43,945.20       | 1,200.00<br>299.99                     | 2.76%                    |
| United Parcel Service Inc Sr Nt<br>2.50% Dtd 11/14/2017 Due 04/01/2023<br>Callable                    | 100,000.000  | 105,065.00<br>105,153.00     | 2,500.00<br>625.00                     | 2.38%                    |
| US Treasury Note<br>1.625% Dtd 11/30/2015 Due 11/30/2020  | 110,000.000  | 110,649.00<br>110,031.11     | 1,787.00<br>151.40                     | 1.62%                    |
| US Treasury Note<br>1.125% Dtd 01/15/2011 Due 01/15/2021<br>Treasury Inflation Protection<br>Security | 70,338.600   | 70,980.79<br>69,959.46       | 791.00<br>367.73                       | 1.11%                    |
| US Treasury Note<br>0.125% Dtd 04/15/2016 Due 04/15/2021<br>Treasury Inflation Protection<br>Security | 108,202.000  | 108,717.04<br>107,939.16     | 135.00<br>28.63                        | 0.12%                    |
| US Treasury Note<br>1.375% Dtd 09/15/2017 Due 09/15/2020  | 100,000.000  | 100,249.00<br>100,243.42     | 1,375.00<br>403.53                     | 1.37%                    |
| US Treasury Note<br>1.875% Dtd 12/15/2017 Due 12/15/2020  | 100,000.000  | 100,779.00<br>100,523.34     | 1,875.00<br>81.96                      | 1.86%                    |
| US Treasury Note<br>2.375% Dtd 03/15/2018 Due 03/15/2021  | 50,000.000   | 50,775.50<br>50,777.27       | 1,187.00<br>348.50                     | 2.34%                    |



**WBSD - EMERGENCY CAPITAL RESERVE**

Account Number:  
Statement Period:

04/01/20 -  
06/30/20

**Asset Position As of 06/30/20**

| Asset Description   | Units       | Market Value<br>Cost                             | Est. Annual Income<br>Accruals       | Current<br>Yield |
|---|-------------|--|--------------------------------------|------------------|
| US Treasury Note<br>2.75% Dtd 09/15/2018 Due 09/15/2021                                 | 100,000.000 | 103,114.00<br>99,695.31                          | 2,750.00<br>807.06                   | 2.67%            |
| US Treasury Note<br>2.50% Dtd 01/31/2019 Due 01/31/2021                                 | 100,000.000 | 101,342.00<br>100,833.63                         | 2,500.00<br>1,043.95                 | 2.47%            |
| University Neb Facs Corp Rev Bds<br>5.00% Dtd 08/09/2018 Due 07/15/2021<br>Non-Callable | 50,000.000  | 52,349.00<br>52,211.50                           | 2,500.00<br>1,152.77                 | 4.78%            |
| <b>Total Fixed Income</b>   |             | <b>\$ 3,732,807.79</b><br><b>\$ 3,707,516.52</b> | <b>89,730.00</b><br><b>25,327.41</b> | <b>2.40%</b>     |
| <b>Cash</b>   |             |  |                                      |                  |
| Principal Cash  |             | 0.00<br>0.00                                     | 0.00                                 | 0.00%            |
| Income Cash   |             | 0.00<br>0.00                                     | 0.00                                 | 0.00%            |
| <b>Total Cash</b>   |             | <b>\$ 0.00</b><br><b>\$ 0.00</b>                 | <b>0.00</b><br><b>0.00</b>           | <b>0.00%</b>     |
| <b>Total Market Value</b>   |             | <b>\$ 3,879,346.27</b><br><b>\$ 3,854,055.00</b> | <b>89,905.00</b><br><b>25,356.22</b> | <b>2.32%</b>     |
| <b>Total Market Value Plus Accruals</b>   |             | <b>\$ 3,904,702.49</b>                           |                                      |                  |

**Income Activity**

|  | Date     | Income Cash | Principal Cash |
|--|----------|-------------|----------------|
| <b>Interest Income</b>   |          |             |                |
| Bank of The West Advantage Acct  |          |             |                |
| Int To 03/31/20  | 04/01/20 |             | 112.61         |
| Int To 04/30/20  | 05/01/20 |             | 122.40         |
| Int To 05/31/20  | 06/01/20 |             | 101.64         |
| Federal Home Ln Mtg Corp Partn Gold<br>Group #G13107 5.500% Dtd 03/01/2008<br>Due 07/01/2020 IPD14 |          |             |                |
| Int For March 2020 on 16.64  | 04/15/20 |             | 0.08           |
| Int For April 2020 on 1.42   | 05/15/20 |             | 0.01           |





**WBSD - EMERGENCY CAPITAL RESERVE**

Account Number:  
 Statement Period:

04/01/20 -  
 06/30/20

| Income Activity  |          |             |                |
|--|----------|-------------|----------------|
|  | Date     | Income Cash | Principal Cash |
| Federal Home Ln Mtg Corp Partn Gold<br>Group #G11940 5.500% Dtd 03/01/2006<br>Due 05/01/2020 IPD14 |          |             |                |
| Int For March 2020 on 39.31  | 04/15/20 |             | 0.18           |
| Int For April 2020 on 14.37  | 05/15/20 |             | 0.07           |
| Federal Home Loan Bks Cons Bds<br>Step Cpn Dtd 04/27/2017 Due<br>04/27/2022 Callable               |          |             |                |
| Int To 04/27/20 on 120,000   | 04/28/20 |             | 1,380.00       |
| Federal Home Loan Bks Cons Bds<br>1.70% Dtd 07/27/2016 Due 07/27/2022<br>Callable                  |          |             |                |
| Interest At Full Call of   | 04/23/20 |             | 568.56         |
| Federal Farm Cr Bks Cons Systemwide<br>Bds 1.64% Dtd 12/11/2019 Due<br>06/11/2021 Callable         |          |             |                |
| Interest At Full Call of   | 04/01/20 |             | 551.22         |
| Federal Home Loan Bks Cons Bds<br>3.125% Dtd 11/17/2010 Due 12/11/2020<br>Non-Callable             |          |             |                |
| Int To 06/11/20 on 110,000   | 06/11/20 |             | 1,718.75       |
| Federal Home Ln Mtg Corp Medium<br>Term Nts 1.625% Dtd 04/27/2017 Due<br>07/27/2020 Callable       |          |             |                |
| Int To 04/27/20 on 40,000  | 04/27/20 |             | 325.00         |
| Federal Home Ln Mtg Corp<br>1.65% Dtd 04/27/2017 Due 04/27/2020<br>Callable                        |          |             |                |
| Int To 04/27/20 on 150,000   | 04/27/20 |             | 1,237.50       |
| Federal Natl Mtg Assn<br>1.50% Dtd 04/27/2015 Due 06/22/2020<br>Non-Callable                       |          |             |                |
| Int To 06/22/20 on 25,000  | 06/22/20 |             | 187.50         |
| Federal Natl Mtg Assn<br>1.50% Dtd 10/19/2015 Due 11/30/2020<br>Non-Callable                       |          |             |                |
| Int To 05/30/20 on 275,000   | 06/01/20 |             | 2,062.50       |
| Federal Natl Mtg Assn<br>1.875% Dtd 11/16/2015 Due 12/28/2020<br>Non-Callable                      |          |             |                |
| Int To 06/28/20 on 40,000  | 06/29/20 |             | 375.00         |



**WBSD - EMERGENCY CAPITAL RESERVE**

Account Number:  
Statement Period:

04/01/20 -  
06/30/20

| Income Activity   |                      |             |                  |
|---|----------------------|-------------|------------------|
|   | Date                 | Income Cash | Principal Cash   |
| Federal Natl Mtg Assn<br>1.375% Dtd 10/07/2016 Due 10/07/2021<br>Non-Callable<br>Int To 04/07/20 on 60,000                          | 04/07/20             |             | 412.50           |
| Federal Natl Mtg Assn<br>1.80% Dtd 10/26/2012 Due 10/26/2021<br>Callable<br>Int To 04/26/20 on 100,000<br>Interest At Full Call of  | 04/27/20<br>06/26/20 |             | 900.00<br>300.00 |
| Federal Natl Mtg Assn<br>1.50% Dtd 11/27/2012 Due 11/27/2020<br>Callable<br>Int To 05/27/20 on 200,000                              | 05/27/20             |             | 1,500.00         |
| Federal Home Ln Mtg Corp<br>1.375% Dtd 04/04/2013 Due 05/01/2020<br>Non-Callable<br>Int To 05/01/20 on 200,000                      | 05/01/20             |             | 1,375.00         |
| Federal Natl Mtg Assn Gtd Passthru<br>CTF Pool #797828 5.000% Dtd<br>04/01/2005 Due 04/01/2020 IPD24<br>Int For March 2020 on 55.86 | 04/27/20             |             | 0.23             |
| Home Depot Inc Sr Gbl Nt<br>2.00% Dtd 02/12/2016 Due 04/01/2021<br>Callable<br>Int To 04/01/20 on 60,000                            | 04/01/20             |             | 600.00           |
| Michigan St GO Ref Bds 2009a Taxable<br>6.95% Dtd 04/14/2009 Due 11/01/2020<br>Non-Callable<br>Int To 05/01/20 on 25,000            | 05/01/20             |             | 868.75           |
| 3M Co Fr<br>2.00% Dtd 06/26/2012 Due 06/26/2022<br>Non-Callable<br>Int To 06/26/20 on 100,000                                       | 06/26/20             |             | 1,000.00         |
| US Treasury Note<br>1.625% Dtd 11/30/2015 Due 11/30/2020<br>Int To 05/31/20 on 110,000  | 06/01/20             |             | 893.75           |
| US Treasury Note<br>0.125% Dtd 04/15/2016 Due 04/15/2021<br>Treasury Inflation Protection<br>Security<br>Int To 04/15/20 on 108985  | 04/15/20             |             | 68.12            |



**WBSD - EMERGENCY CAPITAL RESERVE**

Account Number:  
 Statement Period:

04/01/20 -  
 06/30/20

| Income Activity   |          |                |                     |
|---|----------|----------------|---------------------|
|   | Date     | Income Cash    | Principal Cash      |
| US Treasury Note<br>1.875% Dtd 12/15/2017 Due 12/15/2020<br>Int To 06/15/20 on 100,000  | 06/15/20 |                | 937.50              |
| <b>Total Interest Income</b>  |          | <b>\$ 0.00</b> | <b>\$ 17,598.87</b> |
| <b>Purchased Income</b>   |          |                |                     |
| American Express Co Sr Gbl<br>2.50% Dtd 07/30/2019 Due 07/30/2024<br>Callable<br>Accrued Int To 06/19/20 Paid on<br>Purchase of 100,000           | 06/19/20 |                | -965.28             |
| Apple Inc Sr Gbl Nt<br>0.75% Dtd 05/11/2020 Due 05/11/2023<br>Callable<br>Accrued Int To 06/02/20 Paid on<br>Purchase of 25,000                   | 06/02/20 |                | -10.94              |
| Autozone Inc Sr Gbl<br>2.50% Dtd 04/29/2015 Due 04/15/2021<br>Callable<br>Accrued Int To 05/29/20 Paid on<br>Purchase of 45,000                   | 05/29/20 |                | -137.50             |
| Credit Suisse Ag New York Bran Fr<br>2.80% Dtd 04/09/2020 Due 04/08/2022<br>Non-Callable<br>Accrued Int To 05/29/20 Paid on<br>Purchase of 45,000 | 05/29/20 |                | -175.00             |
| Disney Walt Co Sr Gbl Nt<br>1.65% Dtd 09/06/2019 Due 09/01/2022<br>Callable<br>Accrued Int To 05/29/20 Paid on<br>Purchase of 45,000              | 05/29/20 |                | -181.50             |
| Exxon Mobil Corp Sr Gbl Nt<br>1.902% Dtd 08/16/2019 Due 08/16/2022<br>Callable<br>Accrued Int To 06/02/20 Paid on<br>Purchase of 45,000           | 06/02/20 |                | -252.01             |
| Harley Davidson Finl Svcs Inc Fr<br>2.55% Dtd 06/09/2017 Due 06/09/2022<br>Callable<br>Accrued Int To 06/19/20 Paid on<br>Purchase of 100,000     | 06/19/20 |                | -70.84              |



**WBSD - EMERGENCY CAPITAL RESERVE**

Account Number:  
 Statement Period:

04/01/20 -  
 06/30/20

| Income Activity   |          |             |                |
|---|----------|-------------|----------------|
|   | Date     | Income Cash | Principal Cash |
| JPMorgan Chase & Co Sr Nt<br>3.25% Dtd 09/24/2012 Due 09/23/2022<br>Non-Callable<br>Accrued Int To 05/29/20 Paid on<br>Purchase of 45,000                                 | 05/29/20 |             | -268.13        |
| Jackson Cnty MO Reorg Sch Dist GO<br>Sch Bldg Bds 2009c Taxable 4.90% Dtd<br>11/15/2009 Due 03/01/2021 Callable<br>Accrued Int To 04/17/20 Paid on<br>Purchase of 100,000 | 04/17/20 |             | -626.11        |
| Lawrence Kans GO Impt Bds 2017 D<br>5.00% Dtd 09/28/2017 Due 09/01/2021<br>Non-Callable<br>Accrued Int To 04/28/20 Paid on<br>Purchase of 70,000                          | 04/28/20 |             | -554.17        |
| Mississippi St Univ Edl Bldg C Rev<br>Bds 4.00% Dtd 05/17/2017 Due<br>08/01/2021 Non-Callable<br>Accrued Int To 04/28/20 Paid on<br>Purchase of 60,000                    | 04/28/20 |             | -580.00        |
| Morgan Stanley Fr<br>5.75% Dtd 01/25/2011 Due 01/25/2021<br>Callable<br>Accrued Int To 05/29/20 Paid on<br>Purchase of 45,000   | 05/29/20 |             | -891.25        |
| New York N Y GO Bds Subser Taxable<br>4.669% Dtd 10/15/2009 Due 10/01/2022<br>Callable<br>Accrued Int To 04/15/20 Paid on<br>Purchase of 45,000                           | 04/15/20 |             | -81.71         |
| New York St Dorm Auth Revs Non Univ<br>Rev Bds 2019b Taxable 2.839% Dtd<br>02/21/2019 Due 07/01/2022 Callable<br>Accrued Int To 04/17/20 Paid on<br>Purchase of 100,000   | 04/17/20 |             | -835.93        |
| Toyota Motor Credit Corp Fr<br>2.90% Dtd 04/01/2020 Due 03/30/2023<br>Non-Callable<br>Accrued Int To 05/29/20 Paid on<br>Purchase of 50,000                               | 05/29/20 |             | -233.61        |



**WBSD - EMERGENCY CAPITAL RESERVE**

Account Number:  
 Statement Period:

04/01/20 -  
 06/30/20

| Income Activity  |          |                |                     |
|--|----------|----------------|---------------------|
|  | Date     | Income Cash    | Principal Cash      |
| Toyota Motor Credit Corp Fr<br>3.00% Dtd 04/01/2020 Due 04/01/2025<br>Callable<br>Accrued Int To 06/19/20 Paid on<br>Purchase of 40,000                            | 06/19/20 |                | -260.00             |
| United Parcel Service Inc Sr Nt<br>2.50% Dtd 11/14/2017 Due 04/01/2023<br>Callable<br>Accrued Int To 06/19/20 Paid on<br>Purchase of 100,000                       | 06/19/20 |                | -541.67             |
| US Treasury Note<br>1.125% Dtd 01/15/2011 Due 01/15/2021<br>Treasury Inflation Protection<br>Security<br>Accrued Int To 04/15/20 Paid on<br>Purchase of 70,847.400 | 04/15/20 |                | -199.26             |
| University Neb Facs Corp Rev Bds<br>5.00% Dtd 08/09/2018 Due 07/15/2021<br>Non-Callable<br>Accrued Int To 04/17/20 Paid on<br>Purchase of 50,000                   | 04/17/20 |                | -638.89             |
| <b>Total Purchased Income</b>  |          | <b>\$ 0.00</b> | <b>\$ -7,503.80</b> |
| <b>Total Income</b>  |          | <b>\$ 0.00</b> | <b>\$ 10,095.07</b> |

| Additions   |          |                |                      |
|---|----------|----------------|----------------------|
|   | Date     | Income Cash    | Principal Cash       |
| <b>Miscellaneous Additions</b>  |          |                |                      |
| Addition To Account<br>ACH Transfer From Bank of The West<br>Ckg Ending In 6049 Per Instruction<br>4/8/20 | 04/10/20 |                | 200,000.00           |
| <b>Total Miscellaneous Additions</b>  |          | <b>\$ 0.00</b> | <b>\$ 200,000.00</b> |
| <b>Total Additions</b>  |          | <b>\$ 0.00</b> | <b>\$ 200,000.00</b> |



**WBSD - EMERGENCY CAPITAL RESERVE**

Account Number:  
 Statement Period:

04/01/20 -  
 06/30/20

| Disbursement Activity      |          |                |                     |
|----------------------------|----------|----------------|---------------------|
|                            | Date     | Income Cash    | Principal Cash      |
| <b>Fees/Expenses</b>       |          |                |                     |
| Monthly Fee To 03/31/20    | 04/15/20 |                | -645.74             |
| Monthly Fee To 04/30/20    | 05/15/20 |                | -658.74             |
| Monthly Fee To 05/31/20    | 06/15/20 |                | -658.84             |
| <b>Total Fees/Expenses</b> |          | <b>\$ 0.00</b> | <b>\$ -1,963.32</b> |
| <b>Total Disbursements</b> |          | <b>\$ 0.00</b> | <b>\$ -1,963.32</b> |

| Purchase Activity   |          |             |                |
|---|----------|-------------|----------------|
|   | Date     | Income Cash | Principal Cash |
| Bank of The West Advantage Acct<br>Purchases (14) 04/01/20 To 06/30/20  | 06/30/20 |             | -1,141,222.14  |
| American Express Co Sr Gbl<br>2.50% Dtd 07/30/2019 Due 07/30/2024<br>Callable<br>Purchased 100000 06/17/20<br>From BNY Mellon/Toronto Dominion Sec<br>@ 105.752           | 06/19/20 |             | -105,752.00    |
| Apple Inc Sr Gbl Nt<br>0.75% Dtd 05/11/2020 Due 05/11/2023<br>Callable<br>Purchased 25000 05/29/20<br>From BNY Mellon/Toronto Dominion Sec<br>@ 101.187                   | 06/02/20 |             | -25,296.75     |
| Autozone Inc Sr Gbl<br>2.50% Dtd 04/29/2015 Due 04/15/2021<br>Callable<br>Purchased 45000 05/27/20<br>From BNY Mellon/Toronto Dominion Sec<br>@ 101.342                   | 05/29/20 |             | -45,603.90     |
| Credit Suisse Ag New York Bran Fr<br>2.80% Dtd 04/09/2020 Due 04/08/2022<br>Non-Callable<br>Purchased 45000 05/27/20<br>From BNY Mellon/Toronto Dominion Sec<br>@ 103.644 | 05/29/20 |             | -46,639.80     |



**WBSD - EMERGENCY CAPITAL RESERVE**

Account Number:  
 Statement Period:

04/01/20 -  
 06/30/20

| Purchase Activity   |          |             |                |
|---|----------|-------------|----------------|
|   | Date     | Income Cash | Principal Cash |
| Disney Walt Co Sr Gbl Nt<br>1.65% Dtd 09/06/2019 Due 09/01/2022<br>Callable<br>Purchased 45000 05/27/20<br>From BNY Mellon/Toronto Dominion Sec<br>@ 102.122                          | 05/29/20 |             | -45,954.90     |
| Exxon Mobil Corp Sr Gbl Nt<br>1.902% Dtd 08/16/2019 Due 08/16/2022<br>Callable<br>Purchased 45000 05/29/20<br>From BNY Mellon/Toronto Dominion Sec<br>@ 103.201                       | 06/02/20 |             | -46,440.45     |
| Harley Davidson Finl Svcs Inc Fr<br>2.55% Dtd 06/09/2017 Due 06/09/2022<br>Callable<br>Purchased 100000 06/17/20<br>From BNY Mellon/Toronto Dominion Sec<br>@ 100.65                  | 06/19/20 |             | -100,650.00    |
| JPMorgan Chase & Co Sr Nt<br>3.25% Dtd 09/24/2012 Due 09/23/2022<br>Non-Callable<br>Purchased 45000 05/27/20<br>From BNY Mellon/Toronto Dominion Sec<br>@ 105.375                     | 05/29/20 |             | -47,418.75     |
| Jackson Cnty MO Reorg Sch Dist GO<br>Sch Bldg Bds 2009c Taxable 4.90% Dtd<br>11/15/2009 Due 03/01/2021 Callable<br>Purchased 100000 04/15/20<br>From Wedbush Morgan Secs<br>@ 102.818 | 04/17/20 |             | -102,818.00    |
| Lawrence Kans GO Impt Bds 2017 D<br>5.00% Dtd 09/28/2017 Due 09/01/2021<br>Non-Callable<br>Purchased 70000 04/24/20<br>From Stifel Nicolaus & Co<br>@ 104.903                         | 04/28/20 |             | -73,432.10     |
| Mississippi St Univ Edl Bldg C Rev<br>Bds 4.00% Dtd 05/17/2017 Due<br>08/01/2021 Non-Callable<br>Purchased 60000 04/24/20<br>From Wells Fargo Securities, LLC<br>@ 103.344            | 04/28/20 |             | -62,006.40     |



**WBSD - EMERGENCY CAPITAL RESERVE**

Account Number:  
 Statement Period:

04/01/20 -  
 06/30/20

| Purchase Activity  |          |             |                |
|--|----------|-------------|----------------|
|  | Date     | Income Cash | Principal Cash |
| Morgan Stanley Fr<br>5.75% Dtd 01/25/2011 Due 01/25/2021<br>Callable<br>Purchased 45000 05/27/20<br>From BNY Mellon/Toronto Dominion Sec<br>@ 103.396                                  | 05/29/20 |             | -46,528.20     |
| New York N Y GO Bds Subser Taxable<br>4.669% Dtd 10/15/2009 Due 10/01/2022<br>Callable<br>Purchased 45000 04/13/20<br>From Headlands Holdings LLC<br>@ 106.377                         | 04/15/20 |             | -47,869.65     |
| New York St Dorm Auth Revs Non Univ<br>Rev Bds 2019b Taxable 2.839% Dtd<br>02/21/2019 Due 07/01/2022 Callable<br>Purchased 100000 04/15/20<br>From Headlands Holdings LLC<br>@ 102.432 | 04/17/20 |             | -102,432.00    |
| San Diego Tex Indpt Sch Dist Unltd<br>Tax Ref Bds 3.00% Dtd 05/15/2020 Due<br>08/15/2022 Non-Callable<br>Purchased 100000 04/27/20<br>From Oppenheimer & Co Inc<br>@ 103.953           | 05/21/20 |             | -103,953.00    |
| Toyota Motor Credit Corp Fr<br>2.90% Dtd 04/01/2020 Due 03/30/2023<br>Non-Callable<br>Purchased 50000 05/27/20<br>From BNY Mellon/Toronto Dominion Sec<br>@ 105.394                    | 05/29/20 |             | -52,697.00     |
| Toyota Motor Credit Corp Fr<br>3.00% Dtd 04/01/2020 Due 04/01/2025<br>Callable<br>Purchased 40000 06/17/20<br>From BNY Mellon/Toronto Dominion Sec<br>@ 109.863                        | 06/19/20 |             | -43,945.20     |
| United Parcel Service Inc Sr Nt<br>2.50% Dtd 11/14/2017 Due 04/01/2023<br>Callable<br>Purchased 100000 06/17/20<br>From BNY Mellon/Toronto Dominion Sec<br>@ 105.153                   | 06/19/20 |             | -105,153.00    |





**WBSD - EMERGENCY CAPITAL RESERVE**

Account Number:  
 Statement Period:

04/01/20 -  
 06/30/20

| Purchase Activity  |          |                |                         |
|--|----------|----------------|-------------------------|
|  | Date     | Income Cash    | Principal Cash          |
| US Treasury Note<br>1.125% Dtd 01/15/2011 Due 01/15/2021<br>Treasury Inflation Protection<br>Security<br>Purchased 70847.400 04/14/20<br>From Wells Fargo Securities, LLC<br>@ 99.464844 | 04/15/20 |                | -70,468.26              |
| University Neb Facs Corp Rev Bds<br>5.00% Dtd 08/09/2018 Due 07/15/2021<br>Non-Callable<br>Purchased 50000 04/15/20<br>From Stifel Nicolaus & Co<br>@ 104.423                            | 04/17/20 |                | -52,211.50              |
| <b>Total Purchases</b>   |          | <b>\$ 0.00</b> | <b>\$ -2,468,493.00</b> |

| Sale Activity  |          |              |                    |
|--|----------|--------------|--------------------|
|  | Date     | Proceeds     | Realized Gain/Loss |
| Bank of The West Advantage Acct<br>Sales (10) 04/01/20 To 06/30/20   | 06/30/20 | 1,335,249.44 |                    |
| Federal Home Ln Mtg Corp Partn Gold<br>Group #G13107 5.500% Dtd 03/01/2008<br>Due 07/01/2020 IPD14<br>Prin Pmt For March 2020                    | 04/15/20 | 15.22        | -18.40             |
| Prin Pmt For April 2020  | 05/15/20 | 0.94         | -1.14              |
| Recd Proceeds on Final Paydown of  | 06/15/20 | 0.48         | -0.58              |
| Federal Home Ln Mtg Corp Partn Gold<br>Group #G11940 5.500% Dtd 03/01/2006<br>Due 05/01/2020 IPD14<br>Prin Pmt For March 2020                    | 04/15/20 | 24.94        | -23.42             |
| Recd Proceeds on Final Paydown of  | 05/15/20 | 14.37        | -13.50             |
| Federal Home Loan Bks Cons Bds<br>1.70% Dtd 07/27/2016 Due 07/27/2022<br>Callable<br>Recd Proceeds on Full Call of<br>140,000 Par Value          | 04/23/20 | 140,000.00   | 3,386.89           |
| Federal Farm Cr Bks Cons Systemwide<br>Bds 1.64% Dtd 12/11/2019 Due<br>06/11/2021 Callable<br>Recd Proceeds on Full Call of<br>110,000 Par Value | 04/01/20 | 110,000.00   |                    |



**WBSD - EMERGENCY CAPITAL RESERVE**

Account Number:  
 Statement Period:

04/01/20 -  
 06/30/20

| Sale Activity   |          |                        |                    |
|---|----------|------------------------|--------------------|
|   | Date     | Proceeds               | Realized Gain/Loss |
| Federal Home Ln Mtg Corp<br>1.65% Dtd 04/27/2017 Due 04/27/2020<br>Callable<br>Recd Proceeds on Maturity of<br>150,000 Par Value          | 04/27/20 | 150,000.00             |                    |
| Federal Natl Mtg Assn<br>1.50% Dtd 04/27/2015 Due 06/22/2020<br>Non-Callable<br>Recd Proceeds on Maturity of<br>25,000 Par Value          | 06/22/20 | 25,000.00              |                    |
| Federal Natl Mtg Assn<br>1.80% Dtd 10/26/2012 Due 10/26/2021<br>Callable<br>Recd Proceeds on Full Call of<br>100,000 Par Value            | 06/26/20 | 100,000.00             |                    |
| Federal Natl Mtg Assn<br>1.50% Dtd 11/27/2012 Due 11/27/2020<br>Callable<br>Recd Proceeds on Full Call of<br>200,000 Par Value            | 05/27/20 | 200,000.00             | 1,371.88           |
| Federal Home Ln Mtg Corp<br>1.375% Dtd 04/04/2013 Due 05/01/2020<br>Non-Callable<br>Recd Proceeds on Maturity of<br>200,000 Par Value     | 05/01/20 | 200,000.00             | 528.00             |
| Federal Natl Mtg Assn Gtd Passthru<br>CTF Pool #797828 5.000% Dtd<br>04/01/2005 Due 04/01/2020 IPD24<br>Recd Proceeds At Final Paydown of | 04/27/20 | 55.86                  | -21.80             |
| <b>Total Sales</b>  |          | <b>\$ 2,260,361.25</b> | <b>\$ 5,207.93</b> |

| Non-Cash Activity  |          |        |
|--|----------|--------|
|  | Date     | Cost   |
| Federal Home Loan Bks Cons Bds<br>1.70% Dtd 07/27/2016 Due 07/27/2022<br>Callable<br>Accretion of Discount | 04/23/20 | 358.03 |
| Federal Home Ln Mtg Corp<br>1.65% Dtd 04/27/2017 Due 04/27/2020<br>Callable<br>Accretion of Discount       | 04/27/20 | 107.83 |



**WBSD - EMERGENCY CAPITAL RESERVE**

**Account Number:**  
**Statement Period:**

**04/01/20 -**  
**06/30/20**

| Non-Cash Activity  |          |         |
|--|----------|---------|
|  | Date     | Cost    |
| Federal Natl Mtg Assn<br>1.50% Dtd 04/27/2015 Due 06/22/2020<br>Non-Callable<br>Amortization of Premium                | 06/22/20 | -53.00  |
| Federal Natl Mtg Assn<br>1.50% Dtd 10/19/2015 Due 11/30/2020<br>Non-Callable<br>Amortization of Premium                | 05/29/20 | -37.50  |
| Federal Natl Mtg Assn<br>1.875% Dtd 11/16/2015 Due 12/28/2020<br>Non-Callable<br>Amortization of Premium               | 06/26/20 | -127.20 |
| Federal Natl Mtg Assn<br>1.375% Dtd 02/05/2016 Due 02/26/2021<br>Non-Callable<br>Accretion of Discount                 | 04/30/20 | 14.25   |
| Accretion of Discount  | 05/29/20 | 14.25   |
| Accretion of Discount  | 06/30/20 | 14.25   |
| Federal Natl Mtg Assn<br>1.375% Dtd 10/07/2016 Due 10/07/2021<br>Non-Callable<br>Accretion of Discount                 | 04/30/20 | 16.71   |
| Accretion of Discount  | 05/29/20 | 16.71   |
| Accretion of Discount  | 06/30/20 | 16.71   |
| Federal Natl Mtg Assn<br>1.50% Dtd 11/27/2012 Due 11/27/2020<br>Callable<br>Accretion of Discount                      | 04/30/20 | 91.00   |
| Accretion of Discount  | 04/30/20 | 136.51  |
| Accretion of Discount  | 05/27/20 | 79.26   |
| Accretion of Discount  | 05/27/20 | 118.90  |
| Michigan St GO Ref Bds 2009a Taxable<br>6.95% Dtd 04/14/2009 Due 11/01/2020<br>Non-Callable<br>Amortization of Premium | 05/01/20 | -408.75 |
| 3M Co Fr<br>2.00% Dtd 06/26/2012 Due 06/26/2022<br>Non-Callable<br>Accretion of Discount                               | 04/30/20 | 22.27   |
| Accretion of Discount  | 05/29/20 | 22.27   |
| Accretion of Discount  | 06/30/20 | 22.27   |
| US Treasury Note<br>1.625% Dtd 11/30/2015 Due 11/30/2020<br>Amortization of Premium                                    | 05/29/20 | -20.45  |



**WBSD - EMERGENCY CAPITAL RESERVE**

Account Number:  
 Statement Period:

04/01/20 -  
 06/30/20

**Non-Cash Activity**

|   | Date     | Cost                |
|---|----------|---------------------|
| US Treasury Note<br>1.125% Dtd 01/15/2011 Due 01/15/2021<br>Treasury Inflation Protection<br>Security |          |                     |
| Inflationary Int Adjustment 04/29/20  | 04/29/20 | 97.20               |
| Inflationary Int Adjustment 05/14/20  | 05/14/20 | -63.60              |
| Inflationary Int Adjustment 05/28/20  | 05/28/20 | -79.80              |
| Inflationary Int Adjustment 06/12/20  | 06/12/20 | -225.60             |
| Inflationary Int Adjustment 06/30/20  | 06/30/20 | -237.00             |
| US Treasury Note<br>0.125% Dtd 04/15/2016 Due 04/15/2021<br>Treasury Inflation Protection<br>Security |          |                     |
| Inflationary Int Adjustment 04/14/20  | 04/14/20 | 153.00              |
| Inflationary Int Adjustment 04/29/20  | 04/29/20 | 149.00              |
| Inflationary Int Adjustment 05/14/20  | 05/14/20 | -98.00              |
| Inflationary Int Adjustment 05/28/20  | 05/28/20 | -122.00             |
| Inflationary Int Adjustment 06/12/20  | 06/12/20 | -348.00             |
| Inflationary Int Adjustment 06/30/20  | 06/30/20 | -364.00             |
| US Treasury Note<br>1.875% Dtd 12/15/2017 Due 12/15/2020<br>Amortization of Premium                   |          |                     |
|   | 06/15/20 | -293.07             |
| <b>Total Non-Cash Transactions</b>  |          | <b>\$ -1,027.55</b> |

SECURITY PRICES CONTAINED IN THIS STATEMENT ARE OBTAINED FROM THE MOST RELIABLE SOURCES AVAILABLE BUT ARE NOT GUARANTEED BY BANK OF THE WEST. QUOTED PRICES MAY NOT EQUAL ACTUAL PRICES BECAUSE OF SECURITY SIZE, MARKET PRICE, TERM AND DEMAND.



## **Electronic Funds Transfers**

### Preauthorized Transfers:

You may request an electronic fund transfer (EFT), such as an ACH transfer from or deposit to your account, by contacting your account Administrator. You may also preauthorize periodic EFTs by contacting your account Administrator. If you would like to know whether a preauthorized EFT has occurred, please contact your account Administrator at the phone number listed on the first page of your statement, or call 1-877-898-1003 (TTY 1-800-659-5495) between the hours of 8:00 A.M. to 5:00 P.M. Pacific Standard Time.

### Error Resolution Notice:

If you think a statement or receipt is wrong or if you need more information about an EFT listed on a statement or receipt, telephone us at 1-877-898-1003 (TTY 1-800-659-5495) between the hours of 8:00 A.M. to 5:00 P.M. Pacific Standard Time, write to us at Bank of the West, 13300 Crossroads Parkway North, City of Industry, CA 91746, or e-mail us at [WMGIFSOperations@bankofthewest.com](mailto:WMGIFSOperations@bankofthewest.com) as soon as possible. We must hear from you no later than 60 days after we sent the FIRST statement on which the problem or error appeared.

1. Tell us your name and account number (if any).
2. Tell us the dollar amount of the suspected error.
3. Describe the error or the transfer you are unsure about, and explain as clearly as you can why you believe it is an error or why you need more information.

If you contact us verbally, we may require that you send us your complaint or question in writing within 10 business days. We will investigate your complaint and will correct any error promptly. If we take more than 10 business days to do this, we will credit your account for the amount you think is in error, so that you will have the use of the money during the time it takes us to complete our investigation.



**WBSD - OPERATING RESERVE**

Account Number: 04/01/20 -  
 Statement Period: 06/30/20

WEST BAY SANITARY DISTRICT  
 ATTN: PHILLIP L. SCOTT  
 500 LAUREL STREET  
 MENLO PARK CA 94025

**Fiduciary**  
 Chuen Ying Lee  
 (408) 645-3234  
**Portfolio**  
 Michael D. Smith  
 (408) 490-2079

**Asset Allocation**

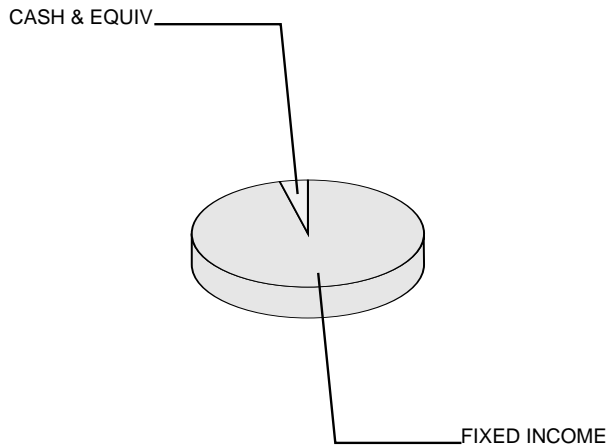

**Asset Valuation**

| Description            | Market Value           | % of Account  |
|------------------------|------------------------|---------------|
| Cash & Equiv           | 374,221.60             | 4.0%          |
| Fixed Income           | 9,095,785.00           | 96.1%         |
| <b>Total Portfolio</b> | <b>\$ 9,470,006.60</b> | <b>100.0%</b> |
| Accrued Income         | 60,896.75              |               |
| <b>Total Valuation</b> | <b>\$ 9,530,903.35</b> |               |

**Market Reconciliation**

|   | Current Period         | Year To Date           |
|---|------------------------|------------------------|
| <b>Beginning Market Value</b>                     | <b>\$ 8,166,101.26</b> | <b>\$ 7,191,676.47</b> |
| Income  |                        |                        |
| Interest.....                                     | 54,483.65              | 190,875.58             |
| Purchased Income.....                             | -29,768.52             | -37,527.67             |
| Additions.....                                    | 1,300,000.00           | 1,300,000.00           |
| Disbursements.....                                | -4,640.47              | -1,410,681.32          |
| Cash Transfers.....                               | 0.00                   | 9,000.00               |
| Realized Gains/(Losses).....                      | 1,075.85               | 19,051.44              |
| Change In Accrued Income.....                     | 25,745.32              | 22,873.90              |
| Change In Market Appreciation/(Depreciation)..... | 24,468.18              | 105,271.84             |
| Non-Cash Asset Changes.....                       | -6,561.92              | 2,140,363.11           |
| <b>Ending Market Value</b>                        | <b>\$ 9,530,903.35</b> | <b>\$ 9,530,903.35</b> |



**WBSD - OPERATING RESERVE**

Account Number:  
Statement Period:

04/01/20 -  
06/30/20

**Asset Position As of 06/30/20**

| Asset Description   | Units       | Market Value<br>Cost                         | Est. Annual Income<br>Accruals | Current<br>Yield |
|---|-------------|--|--------------------------------|------------------|
| <b>Cash Equivalents</b>   |             |  |                                |                  |
| Bank of The West Advantage Acct   | 374,221.600 | 374,221.60<br>374,221.60                     | 449.00<br>36.67                | 0.12%            |
| <b>Total Cash Equivalents</b>   |             | <b>\$ 374,221.60</b><br><b>\$ 374,221.60</b> | <b>449.00</b><br><b>36.67</b>  | <b>0.12%</b>     |
| <b>Fixed Income</b>   |             |  |                                |                  |
| Alabama St GO Ref Bds 2014 A<br>5.00% Dtd 08/06/2014 Due 08/01/2022<br>Non-Callable                     | 75,000.000  | 82,245.75<br>81,462.00                       | 3,750.00<br>1,562.50           | 4.56%            |
| American Express Co Sr Gbl<br>2.50% Dtd 07/30/2019 Due 07/30/2024<br>Callable                           | 100,000.000 | 105,843.00<br>105,752.00                     | 2,500.00<br>1,048.61           | 2.36%            |
| Apple Inc Sr Gbl Nt<br>0.75% Dtd 05/11/2020 Due 05/11/2023<br>Callable                                  | 20,000.000  | 20,210.80<br>20,237.40                       | 150.00<br>20.83                | 0.74%            |
| Atlantic Richfield Co Deb<br>8.25% Dtd 02/01/1992 Due 02/01/2022<br>Non-Callable                        | 15,000.000  | 16,445.55<br>16,635.00                       | 1,237.00<br>515.62             | 7.52%            |
| Austin Tex Pub Ppty Fin Contractual<br>5.00% Dtd 10/03/2018 Due 11/01/2021<br>Non-Callable              | 85,000.000  | 90,347.35<br>89,983.55                       | 4,250.00<br>708.33             | 4.70%            |
| Autozone Inc Sr Gbl<br>2.50% Dtd 04/29/2015 Due 04/15/2021<br>Callable                                  | 45,000.000  | 45,627.30<br>45,603.90                       | 1,125.00<br>237.50             | 2.47%            |
| Capital One Bk USA Natl Assn CTF Dep<br>1.40% Dtd 09/28/2016 Due 09/28/2020<br>Non-Callable             | 100,000.000 | 100,284.00<br>100,000.00                     | 1,400.00<br>364.38             | 1.40%            |
| Clackamas Cnty Ore Sch Dist No GO<br>Ref Bds 5.00% Dtd 06/13/2017 Due<br>06/15/2021 Non-Callable        | 75,000.000  | 78,381.00<br>77,923.50                       | 3,750.00<br>166.66             | 4.78%            |
| Colorado St Brd Governors Univ Rev<br>Ref Bds 2012b 5.00% Dtd 05/01/2012<br>Due 03/01/2023 Non-Callable | 125,000.000 | 139,795.00<br>137,822.50                     | 6,250.00<br>2,083.33           | 4.47%            |
| Credit Suisse Ag New York Bran Fr<br>2.80% Dtd 04/09/2020 Due 04/08/2022<br>Non-Callable                | 40,000.000  | 41,498.80<br>41,457.60                       | 1,120.00<br>255.11             | 2.70%            |



**WBSD - OPERATING RESERVE**

**Account Number:**  
**Statement Period:**

**04/01/20 -**  
**06/30/20**

**Asset Position As of 06/30/20**

| <b>Asset Description</b>   | <b>Units</b> | <b>Market Value<br/>Cost</b> | <b>Est. Annual Income<br/>Accruals</b> | <b>Current<br/>Yield</b> |
|--|--------------|------------------------------|--|--------------------------|
| Disney Walt Co Sr Gbl Nt<br>1.65% Dtd 09/06/2019 Due 09/01/2022<br>Callable                        | 35,000.000   | 35,814.80<br>35,742.70       | 577.00<br>192.50                       | 1.61%                    |
| Exxon Mobil Corp Sr Gbl Nt<br>1.902% Dtd 08/16/2019 Due 08/16/2022<br>Callable                     | 35,000.000   | 36,090.95<br>36,120.35       | 665.00<br>249.63                       | 1.84%                    |
| Fyi Pptys Wash Lease Rev Ref Bds<br>5.00% Dtd 03/05/2019 Due 06/01/2021<br>Non-Callable            | 100,000.000  | 104,201.00<br>103,501.00     | 5,000.00<br>416.66                     | 4.80%                    |
| Federal Home Ln Mtg Corp Partn Gold<br>Group #G11940 5.500% Dtd 03/01/2006<br>Due 05/01/2020 IPD14 |              | 0.00<br>0.00                 | 0.00<br>0.09                           | 0.00%                    |
| Federal Home Loan Bks Cons Bds<br>1.875% Dtd 11/30/2016 Due 11/29/2021<br>Non-Callable             | 200,000.000  | 204,884.00<br>198,831.96     | 3,750.00<br>333.33                     | 1.83%                    |
| Federal Home Loan Bks Cons Bds<br>1.85% Dtd 08/15/2017 Due 08/15/2022<br>Non-Callable              | 235,000.000  | 242,724.45<br>235,972.90     | 4,347.00<br>1,642.38                   | 1.79%                    |
| Federal Farm Cr Bks Cons Systemwide<br>Bds 2.40% Dtd 06/17/2015 Due<br>06/17/2022 Non-Callable     | 235,000.000  | 244,898.20<br>237,848.20     | 5,640.00<br>219.33                     | 2.30%                    |
| Federal Farm Cr Bks Cons Systemwide<br>Bds 1.72% Dtd 07/26/2017 Due<br>07/26/2021 Non-Callable     | 235,000.000  | 238,870.45<br>235,277.30     | 4,042.00<br>1,740.30                   | 1.69%                    |
| Federal Farm Cr Bks Cons Systemwide<br>Bds 1.54% Dtd 02/03/2020 Due<br>02/03/2022 Callable         | 100,000.000  | 100,476.00<br>100,000.00     | 1,540.00<br>641.66                     | 1.53%                    |
| Federal Home Loan Bks Cons Bds<br>2.875% Dtd 08/27/2010 Due 09/11/2020<br>Non-Callable             | 60,000.000   | 60,313.20<br>60,424.80       | 1,725.00<br>527.08                     | 2.86%                    |
| Federal Home Loan Bks Cons Bds<br>1.625% Dtd 11/07/2012 Due 12/10/2021<br>Non-Callable             | 235,000.000  | 239,683.55<br>234,353.75     | 3,818.00<br>222.76                     | 1.59%                    |
| Federal Home Ln Mtg Corp Medium<br>Term Nts 1.625% Dtd 04/27/2017 Due<br>07/27/2020 Callable       | 40,000.000   | 40,040.00<br>40,000.00       | 650.00<br>115.55                       | 1.62%                    |
| Federal Natl Mtg Assn<br>1.50% Dtd 10/19/2015 Due 11/30/2020<br>Non-Callable                       | 150,000.000  | 150,814.50<br>149,634.50     | 2,250.00<br>193.75                     | 1.49%                    |





**WBSD - OPERATING RESERVE**

**Account Number:**  
**Statement Period:**

**04/01/20 -**  
**06/30/20**

**Asset Position As of 06/30/20**

| <b>Asset Description</b>  | <b>Units</b> | <b>Market Value<br/>Cost</b> | <b>Est. Annual Income<br/>Accruals</b> | <b>Current<br/>Yield</b> |
|---|--------------|------------------------------|--|--------------------------|
| Federal Natl Mtg Assn<br>1.875% Dtd 11/16/2015 Due 12/28/2020<br>Non-Callable                                   | 60,000.000   | 60,498.00<br>60,191.40       | 1,125.00<br>9.37                       | 1.86%                    |
| Federal Natl Mtg Assn<br>1.375% Dtd 02/05/2016 Due 02/26/2021<br>Non-Callable                                   | 325,000.000  | 327,411.50<br>323,194.96     | 4,468.00<br>1,551.64                   | 1.36%                    |
| Federal Natl Mtg Assn<br>1.25% Dtd 05/16/2016 Due 05/06/2021<br>Non-Callable                                    | 290,000.000  | 292,636.10<br>288,897.88     | 3,625.00<br>553.81                     | 1.24%                    |
| Federal Natl Mtg Assn<br>1.375% Dtd 10/07/2016 Due 10/07/2021<br>Non-Callable                                   | 325,000.000  | 329,910.75<br>323,456.73     | 4,468.00<br>1,042.70                   | 1.35%                    |
| Federal Natl Mtg Assn<br>2.00% Dtd 01/09/2017 Due 01/05/2022<br>Non-Callable                                    | 505,000.000  | 518,917.80<br>506,051.91     | 10,100.00<br>4,937.77                  | 1.95%                    |
| Federal Natl Mtg Assn<br>1.875% Dtd 04/10/2017 Due 04/05/2022<br>Non-Callable                                   | 160,000.000  | 164,750.40<br>160,716.80     | 3,000.00<br>716.66                     | 1.82%                    |
| Federal Home Ln Mtg Corp<br>2.375% Dtd 01/13/2012 Due 01/13/2022<br>Non-Callable                                | 325,000.000  | 335,835.50<br>329,404.60     | 7,718.00<br>3,602.08                   | 2.30%                    |
| GE Capital Internotes Fr<br>5.50% Dtd 11/05/2009 Due 11/15/2021<br>Non-Callable                                 | 50,000.000   | 52,266.00<br>52,287.50       | 2,750.00<br>351.38                     | 5.26%                    |
| Harley Davidson Finl Svcs Inc Fr<br>2.55% Dtd 06/09/2017 Due 06/09/2022<br>Callable                             | 70,000.000   | 70,249.90<br>70,455.00       | 1,785.00<br>109.07                     | 2.54%                    |
| Home Depot Inc Sr Glbl Nt<br>2.00% Dtd 02/12/2016 Due 04/01/2021<br>Callable                                    | 50,000.000   | 50,593.50<br>49,899.00       | 1,000.00<br>250.00                     | 1.98%                    |
| Indiana Univ Revs Student Fee Bds V<br>Taxable 2.227% Dtd 10/26/2012 Due<br>08/01/2020 Callable                 | 25,000.000   | 25,032.25<br>25,070.50       | 556.00<br>231.97                       | 2.22%                    |
| JPMorgan Chase & Co Sr Nt<br>3.25% Dtd 09/24/2012 Due 09/23/2022<br>Non-Callable                                | 35,000.000   | 36,958.60<br>36,881.25       | 1,137.00<br>309.65                     | 3.08%                    |
| Jackson Cnty MO Reorg Sch Dist GO<br>Sch Bldg Bds 2009c Taxable 4.90% Dtd<br>11/15/2009 Due 03/01/2021 Callable | 120,000.000  | 122,848.80<br>123,381.60     | 5,880.00<br>1,959.99                   | 4.79%                    |



**WBSD - OPERATING RESERVE**

**Account Number:**  
**Statement Period:**

**04/01/20 -**  
**06/30/20**

**Asset Position As of 06/30/20**

| <b>Asset Description</b>  | <b>Units</b> | <b>Market Value<br/>Cost</b> | <b>Est. Annual Income<br/>Accruals</b> | <b>Current<br/>Yield</b> |
|---|--------------|------------------------------|--|--------------------------|
| LA Canada Calif Uni Sch Dist Taxable<br>GO Ref Bds Taxable 1.55% Dtd<br>04/28/2020 Due 08/01/2022<br>Non-Callable                 | 30,000.000   | 30,378.60<br>30,000.00       | 465.00<br>81.37                        | 1.53%                    |
| LA Canada Calif Uni Sch Dist Taxable<br>GO Ref Bds Taxable 1.65% Dtd<br>04/28/2020 Due 08/01/2023<br>Non-Callable                 | 60,000.000   | 61,212.00<br>60,000.00       | 990.00<br>173.25                       | 1.62%                    |
| League City Tex Combi Tax and Rev<br>Cfs O 5.00% Dtd 07/01/2017 Due<br>02/15/2023 Non-Callable                                    | 140,000.000  | 156,185.40<br>154,341.60     | 7,000.00<br>2,644.44                   | 4.48%                    |
| Los Angeles Calif Mun Impt COR Bds<br>2019a 5.00% Dtd 06/26/2019 Due<br>11/01/2023 Non-Callable                                   | 65,000.000   | 74,668.10<br>72,744.90       | 3,250.00<br>541.66                     | 4.35%                    |
| Michigan St GO Ref Bds 2009a Taxable<br>6.95% Dtd 04/14/2009 Due 11/01/2020<br>Non-Callable                                       | 25,000.000   | 25,509.00<br>25,645.50       | 1,737.00<br>289.58                     | 6.81%                    |
| Morgan Stanley Fr<br>5.75% Dtd 01/25/2011 Due 01/25/2021<br>Callable  | 45,000.000   | 46,343.70<br>46,528.20       | 2,587.00<br>1,121.25                   | 5.58%                    |
| Ncua Guaran Nts Tr Ser 2010 R1 CI I<br>A Fltg Rate Dtd 10/27/2010 Due<br>10/07/2020   | 63,148.840   | 63,060.67<br>63,306.71       | 925.00<br>69.28                        | 1.47%                    |
| New Hampshire Health & Ed Facs<br>Taxable Univ Sys Issue B 2017 B<br>Taxable 2.292% Dtd 12/06/2017 Due<br>07/01/2021 Non-Callable | 25,000.000   | 25,205.00<br>25,158.75       | 573.00<br>286.50                       | 2.27%                    |
| New York N Y GO Bds 2010 D Taxable<br>5.199% Dtd 12/17/2009 Due 12/01/2022<br>Callable  | 60,000.000   | 66,337.80<br>65,373.50       | 3,119.00<br>259.95                     | 4.70%                    |
| New York St Dorm Auth Revs Non Univ<br>Rev Bds 2019b Taxable 2.839% Dtd<br>02/21/2019 Due 07/01/2022 Callable                     | 50,000.000   | 51,608.00<br>51,216.00       | 1,419.00<br>709.74                     | 2.75%                    |
| New York St Dorm Auth St Pers Income<br>Tax Rev Bds 2010c Taxable 4.554% Dtd<br>03/11/2010 Due 02/15/2021 Callable                | 25,000.000   | 25,431.75<br>25,620.00       | 1,138.00<br>430.10                     | 4.48%                    |
| Ohio St Common Schs GO Ref Bds 2016<br>A 5.00% Dtd 03/09/2016 Due<br>12/15/2023 Non-Callable                                      | 45,000.000   | 52,138.35<br>50,612.85       | 2,250.00<br>100.00                     | 4.32%                    |



**WBSD - OPERATING RESERVE**

**Account Number:**  
**Statement Period:**

**04/01/20 -**  
**06/30/20**

**Asset Position As of 06/30/20**

| <b>Asset Description</b>   | <b>Units</b> | <b>Market Value<br/>Cost</b> | <b>Est. Annual Income<br/>Accruals</b> | <b>Current<br/>Yield</b> |
|--|--------------|------------------------------|--|--------------------------|
| Port Morrow Ore Transmission F Rev<br>Bds Taxable 2.737% Dtd 08/26/2015<br>Due 09/01/2021 Callable                   | 200,000.000  | 203,928.00<br>203,296.00     | 5,474.00<br>1,824.66                   | 2.68%                    |
| Royal Bk of Cda Bd Cds Fr<br>3.20% Dtd 04/30/2018 Due 04/30/2021<br>Non-Callable                                     | 81,000.000   | 82,941.57<br>82,607.57       | 2,592.00<br>439.20                     | 3.13%                    |
| San Francisco Calif City & Cnt<br>Taxable Ref Bds 2019 A Taxable<br>1.814% Dtd 01/09/2020 Due 11/01/2020<br>Callable | 50,000.000   | 50,213.50<br>50,025.00       | 907.00<br>433.34                       | 1.81%                    |
| Santa Ana Calif Fing Auth Wtr Ref<br>Bds 5.00% Dtd 08/07/2014 Due<br>09/01/2022 Non-Callable                         | 50,000.000   | 55,134.00<br>54,015.50       | 2,500.00<br>833.33                     | 4.53%                    |
| Seattle Wash GO Ref Bds<br>5.00% Dtd 05/16/2012 Due 12/01/2021<br>Non-Callable                                       | 100,000.000  | 106,700.00<br>105,786.00     | 5,000.00<br>416.66                     | 4.69%                    |
| Small Business Admin Gtd Ln Pool<br>Ctfs 2.245% Dtd 09/19/2012 Due<br>09/10/2022                                     | 219,554.760  | 222,716.35<br>222,376.38     | 4,929.00<br>1,648.41                   | 2.21%                    |
| Southwest Tex Indpt Sch Dist Ultd<br>Tax Sch Bldg and RE 5.00% Dtd<br>07/15/2014 Due 02/01/2022<br>Non-Callable      | 110,000.000  | 118,091.60<br>117,536.10     | 5,500.00<br>2,291.67                   | 4.66%                    |
| Starbucks Corp Sr Gbl<br>2.10% Dtd 02/04/2016 Due 02/04/2021<br>Callable   | 50,000.000   | 50,413.00<br>49,987.00       | 1,050.00<br>428.75                     | 2.08%                    |
| 3M Co Fr<br>2.00% Dtd 06/26/2012 Due 06/26/2022<br>Non-Callable  | 100,000.000  | 103,145.00<br>99,468.24      | 2,000.00<br>27.77                      | 1.94%                    |
| Toronto Dominion Bank Fr<br>2.00% Dtd 01/31/2020 Due 01/31/2023<br>Callable  | 100,000.000  | 99,978.00<br>99,756.00       | 2,000.00<br>338.88                     | 2.00%                    |
| Toyota Motor Credit Corp Fr<br>2.90% Dtd 04/01/2020 Due 03/30/2023<br>Non-Callable                                   | 40,000.000   | 42,346.00<br>42,157.60       | 1,160.00<br>290.00                     | 2.74%                    |
| Toyota Motor Credit Corp Fr<br>3.00% Dtd 04/01/2020 Due 04/01/2025<br>Callable                                       | 100,000.000  | 108,683.00<br>109,863.00     | 3,000.00<br>749.99                     | 2.76%                    |



**WBSD - OPERATING RESERVE**

Account Number:  
Statement Period:

04/01/20 -  
06/30/20

**Asset Position As of 06/30/20**

| Asset Description   | Units       | Market Value<br>Cost     | Est. Annual Income<br>Accruals | Current<br>Yield |
|---|-------------|--------------------------|--------------------------------|------------------|
| United Parcel Service Inc Sr Nt<br>2.50% Dtd 11/14/2017 Due 04/01/2023<br>Callable                    | 90,000.000  | 94,558.50<br>94,637.70   | 2,250.00<br>562.49             | 2.38%            |
| US Treasury Note<br>1.625% Dtd 11/30/2015 Due 11/30/2020  | 425,000.000 | 427,507.50<br>423,147.79 | 6,906.00<br>584.95             | 1.62%            |
| US Treasury Note<br>1.125% Dtd 01/15/2011 Due 01/15/2021<br>Treasury Inflation Protection<br>Security | 117,231.000 | 118,301.32<br>116,599.09 | 1,318.00<br>612.88             | 1.11%            |
| US Treasury Note<br>0.125% Dtd 04/15/2016 Due 04/15/2021<br>Treasury Inflation Protection<br>Security | 97,381.800  | 97,845.34<br>97,145.24   | 121.00<br>25.77                | 0.12%            |
| US Treasury Note<br>1.125% Dtd 06/30/2016 Due 06/30/2021  | 100,000.000 | 100,953.00<br>100,348.97 | 1,125.00<br>3.05               | 1.11%            |
| US Treasury Note<br>2.00% Dtd 07/31/2013 Due 07/31/2020   | 40,000.000  | 40,060.80<br>39,898.24   | 800.00<br>334.06               | 2.00%            |
| US Treasury Note<br>1.375% Dtd 09/15/2017 Due 09/15/2020  | 150,000.000 | 150,373.50<br>150,365.13 | 2,062.00<br>605.29             | 1.37%            |
| US Treasury Note<br>1.875% Dtd 12/15/2017 Due 12/15/2020  | 220,000.000 | 221,713.80<br>221,151.36 | 4,125.00<br>180.32             | 1.86%            |
| US Treasury Note<br>2.375% Dtd 03/15/2018 Due 03/15/2021  | 100,000.000 | 101,551.00<br>101,554.54 | 2,375.00<br>697.01             | 2.34%            |
| US Treasury Note<br>2.75% Dtd 09/15/2018 Due 09/15/2021   | 100,000.000 | 103,114.00<br>99,695.31  | 2,750.00<br>807.06             | 2.67%            |
| US Treasury Note<br>2.50% Dtd 01/31/2019 Due 01/31/2021   | 200,000.000 | 202,684.00<br>201,667.26 | 5,000.00<br>2,087.91           | 2.47%            |
| University Calif Revs Gen Rev Bds<br>2015 A Taxable 2.909% Dtd 03/25/2015<br>Due 05/15/2023 Callable  | 135,000.000 | 143,155.35<br>141,370.65 | 3,927.00<br>501.80             | 2.74%            |
| Walnut Calif Energy Ctr Auth R Ref<br>Bds 2014a 5.00% Dtd 07/23/2014 Due<br>01/01/2022 Non-Callable   | 65,000.000  | 69,621.50<br>68,970.85   | 3,250.00<br>1,625.00           | 4.67%            |
| Washington St Various Purp GO Ref<br>Bds R 5.00% Dtd 07/14/2016 Due<br>08/01/2022 Non-Callable        | 100,000.000 | 109,837.00<br>108,780.00 | 5,000.00<br>2,083.33           | 4.55%            |



**WBSD - OPERATING RESERVE**

Account Number:  
 Statement Period:

04/01/20 -  
 06/30/20

**Asset Position As of 06/30/20**

| Asset Description   | Units       | Market Value<br>Cost                             | Est. Annual Income<br>Accruals        | Current<br>Yield |
|---|-------------|--|---------------------------------------|------------------|
| Waxahachie Tex Comb Tax Rev Cfts<br>Oblig 5.00% Dtd 09/19/2018 Due<br>08/01/2021 Non-Callable | 125,000.000 | 131,248.75<br>130,966.25                         | 6,250.00<br>2,604.16                  | 4.76%            |
| Wells Fargo & Co New Sr Gbl<br>2.50% Dtd 03/04/2016 Due 03/04/2021<br>Non-Callable            | 250,000.000 | 253,492.50<br>248,550.00                         | 6,250.00<br>2,031.24                  | 2.47%            |
| <b>Total Fixed Income</b>   |             | <b>\$ 9,095,785.00</b><br><b>\$ 8,986,744.82</b> | <b>222,222.00</b><br><b>60,860.08</b> | <b>2.44%</b>     |
| <b>Cash</b>   |             |  |                                       |                  |
| Principal Cash  |             | 0.00<br>0.00                                     | 0.00                                  | 0.00%            |
| Income Cash   |             | 0.00<br>0.00                                     | 0.00                                  | 0.00%            |
| <b>Total Cash</b>   |             | <b>\$ 0.00</b><br><b>\$ 0.00</b>                 | <b>0.00</b><br><b>0.00</b>            | <b>0.00%</b>     |
| <b>Total Market Value</b>   |             | <b>\$ 9,470,006.60</b><br><b>\$ 9,360,966.42</b> | <b>222,671.00</b><br><b>60,896.75</b> | <b>2.35%</b>     |
| <b>Total Market Value Plus Accruals</b>   |             | <b>\$ 9,530,903.35</b>                           |                                       |                  |

**Income Activity**

|  | Date     | Income Cash | Principal Cash |
|--|----------|-------------|----------------|
| <b>Interest Income</b>   |          |             |                |
| Bank of The West Advantage Acct  |          |             |                |
| Int To 03/31/20  | 04/01/20 |             | 633.69         |
| Int To 04/30/20  | 05/01/20 |             | 398.49         |
| Int To 05/31/20  | 06/01/20 |             | 50.06          |
| Austin Tex Pub Ppty Fin Contractual<br>5.00% Dtd 10/03/2018 Due 11/01/2021<br>Non-Callable |          |             |                |
| Int To 05/01/20 on 85,000  | 05/01/20 |             | 2,125.00       |
| Bank Amer Chrlt NC MTN Sr Gbl FL Nt<br>Var Rate Dtd 05/24/2019 Due<br>05/24/2021 Callable  |          |             |                |
| Int To 05/24/20 on 80,000  | 05/26/20 |             | 406.55         |



**WBSD - OPERATING RESERVE**

Account Number:  
 Statement Period:

04/01/20 -  
 06/30/20

| Income Activity  |                      |             |                 |
|--|----------------------|-------------|-----------------|
|  | Date                 | Income Cash | Principal Cash  |
| Clackamas Cnty Ore Sch Dist No GO<br>Ref Bds 5.00% Dtd 06/13/2017 Due<br>06/15/2021 Non-Callable<br>Int To 06/15/20 on 75,000                                    | 06/15/20             |             | 1,875.00        |
| Constellation Brands Inc Sr Gbl Nt<br>2.25% Dtd 11/07/2017 Due 11/06/2020<br>Callable<br>Int To 05/06/20 on 75,000<br>Interest At Full Call of                   | 05/06/20<br>05/27/20 |             | 843.75<br>98.44 |
| Fyi Pptys Wash Lease Rev Ref Bds<br>5.00% Dtd 03/05/2019 Due 06/01/2021<br>Non-Callable<br>Int To 06/01/20 on 100,000  | 06/01/20             |             | 2,500.00        |
| Federal Home Ln Mtg Corp Partn Gold<br>Group #G13107 5.500% Dtd 03/01/2008<br>Due 07/01/2020 IPD14<br>Int For March 2020 on 16.57<br>Int For April 2020 on 1.41  | 04/15/20<br>05/15/20 |             | 0.08<br>0.01    |
| Federal Home Ln Mtg Corp Partn Gold<br>Group #G11940 5.500% Dtd 03/01/2006<br>Due 05/01/2020 IPD14<br>Int For March 2020 on 40.20<br>Int For April 2020 on 14.70 | 04/15/20<br>05/15/20 |             | 0.18<br>0.07    |
| Federal Home Loan Bks Cons Bds<br>1.875% Dtd 11/30/2016 Due 11/29/2021<br>Non-Callable<br>Int To 05/29/20 on 200,000   | 05/29/20             |             | 1,875.00        |
| Federal Farm Cr Bks Cons Systemwide<br>Bds 2.40% Dtd 06/17/2015 Due<br>06/17/2022 Non-Callable<br>Int To 06/17/20 on 235,000                                     | 06/17/20             |             | 2,820.00        |
| Federal Farm Cr Bks Cons Systemwide<br>Bds 1.64% Dtd 12/11/2019 Due<br>06/11/2021 Callable<br>Interest At Full Call of   | 04/01/20             |             | 501.11          |
| Federal Home Loan Bks Cons Bds<br>4.625% Dtd 05/25/2005 Due 06/12/2020<br>Non-Callable<br>Int To 06/12/20 on 200,000   | 06/12/20             |             | 4,625.00        |
| Federal Home Loan Bks Cons Bds<br>1.625% Dtd 11/07/2012 Due 12/10/2021<br>Non-Callable<br>Int To 06/10/20 on 235,000   | 06/10/20             |             | 1,909.37        |



**WBSD - OPERATING RESERVE**

Account Number:  
Statement Period:

04/01/20 -  
06/30/20

| Income Activity  |                      |             |                    |
|--|----------------------|-------------|--------------------|
|  | Date                 | Income Cash | Principal Cash     |
| Federal Home Loan Bks Cons Bds<br>1.75% Dtd 06/03/2013 Due 06/12/2020<br>Non-Callable<br>Int To 06/12/20 on 60,000                 | 06/12/20             |             | 525.00             |
| Federal Home Ln Mtg Corp Medium<br>Term Nts 1.625% Dtd 04/27/2017 Due<br>07/27/2020 Callable<br>Int To 04/27/20 on 40,000          | 04/27/20             |             | 325.00             |
| Federal Home Ln Mtg Corp<br>1.60% Dtd 05/15/2017 Due 05/15/2020<br>Callable<br>Int To 05/15/20 on 240,000                          | 05/15/20             |             | 1,920.00           |
| Federal Home Ln Mtg Corp<br>1.65% Dtd 01/27/2020 Due 04/27/2022<br>Callable<br>Int 01/27/20 To 04/27/20 on 100000                  | 04/27/20             |             | 412.50             |
| Federal Natl Mtg Assn<br>1.50% Dtd 10/19/2015 Due 11/30/2020<br>Non-Callable<br>Int To 05/30/20 on 150,000                         | 06/01/20             |             | 1,125.00           |
| Federal Natl Mtg Assn<br>1.875% Dtd 11/16/2015 Due 12/28/2020<br>Non-Callable<br>Int To 06/28/20 on 60,000                         | 06/29/20             |             | 562.50             |
| Federal Natl Mtg Assn<br>1.25% Dtd 05/16/2016 Due 05/06/2021<br>Non-Callable<br>Int To 05/06/20 on 290,000                         | 05/06/20             |             | 1,812.50           |
| Federal Natl Mtg Assn<br>1.375% Dtd 10/07/2016 Due 10/07/2021<br>Non-Callable<br>Int To 04/07/20 on 325,000                        | 04/07/20             |             | 2,234.37           |
| Federal Natl Mtg Assn<br>1.875% Dtd 04/10/2017 Due 04/05/2022<br>Non-Callable<br>Int To 04/05/20 on 160,000                        | 04/06/20             |             | 1,500.00           |
| Federal Natl Mtg Assn<br>1.80% Dtd 10/26/2012 Due 10/26/2021<br>Callable<br>Int To 04/26/20 on 200,000<br>Interest At Full Call of | 04/27/20<br>06/26/20 |             | 1,800.00<br>600.00 |



**WBSD - OPERATING RESERVE**

Account Number: 04/01/20 -  
 Statement Period: 06/30/20

| Income Activity  |                                  |             |                         |
|--|----------------------------------|-------------|-------------------------|
|  | Date                             | Income Cash | Principal Cash          |
| Federal Home Ln Mtg Corp<br>1.375% Dtd 04/04/2013 Due 05/01/2020<br>Non-Callable<br>Int To 05/01/20 on 50,000  | 05/01/20                         |             | 343.75                  |
| Federal Natl Mtg Assn Gtd Passthru<br>CTF Pool #797828 5.000% Dtd<br>04/01/2005 Due 04/01/2020 IPD24<br>Int For March 2020 on 59.68  | 04/27/20                         |             | 0.25                    |
| GE Capital Internotes Fr<br>5.50% Dtd 11/05/2009 Due 11/15/2021<br>Non-Callable<br>Int To 05/15/20 on 50,000   | 05/15/20                         |             | 1,375.00                |
| Home Depot Inc Sr Glbl Nt<br>2.00% Dtd 02/12/2016 Due 04/01/2021<br>Callable<br>Int To 04/01/20 on 50,000  | 04/01/20                         |             | 500.00                  |
| Los Angeles Calif Mun Impt COR Bds<br>2019a 5.00% Dtd 06/26/2019 Due<br>11/01/2023 Non-Callable<br>Int To 05/01/20 on 65,000   | 05/01/20                         |             | 1,625.00                |
| Michigan St GO Ref Bds 2009a Taxable<br>6.95% Dtd 04/14/2009 Due 11/01/2020<br>Non-Callable<br>Int To 05/01/20 on 25,000   | 05/01/20                         |             | 868.75                  |
| Ncua Guaran Nts Tr Ser 2010 R1 CI I<br>A Fltg Rate Dtd 10/27/2010 Due<br>10/07/2020<br>Int To 04/06/20 on 70047.81<br>Int To 05/07/20 on 67562.28<br>Int To 06/05/20 on 65547.33 | 04/06/20<br>05/08/20<br>06/05/20 |             | 88.44<br>83.28<br>36.82 |
| New York N Y GO Bds 2010 D Taxable<br>5.199% Dtd 12/17/2009 Due 12/01/2022<br>Callable<br>Int To 06/01/20 on 60,000  | 06/01/20                         |             | 1,559.70                |
| Ohio St Common Schs GO Ref Bds 2016<br>A 5.00% Dtd 03/09/2016 Due<br>12/15/2023 Non-Callable<br>Int To 06/15/20 on 45,000  | 06/15/20                         |             | 1,125.00                |
| Royal Bk of Cda Bd Cds Fr<br>3.20% Dtd 04/30/2018 Due 04/30/2021<br>Non-Callable<br>Int To 04/30/20 on 81,000  | 04/30/20                         |             | 1,296.00                |





**WBSD - OPERATING RESERVE**

Account Number:  
 Statement Period:

04/01/20 -  
 06/30/20

| Income Activity  |          |                |                     |
|--|----------|----------------|---------------------|
|  | Date     | Income Cash    | Principal Cash      |
| Seattle Wash GO Ref Bds<br>5.00% Dtd 05/16/2012 Due 12/01/2021<br>Non-Callable<br>Int To 06/01/20 on 100,000                                 | 06/01/20 |                | 2,500.00            |
| 3M Co Fr<br>2.00% Dtd 06/26/2012 Due 06/26/2022<br>Non-Callable<br>Int To 06/26/20 on 100,000  | 06/26/20 |                | 1,000.00            |
| Toronto Dominion Bank Fr<br>2.00% Dtd 01/31/2020 Due 01/31/2023<br>Callable<br>Int 01/31/20 To 04/30/20 on 100000                            | 04/30/20 |                | 500.00              |
| US Treasury Note<br>1.625% Dtd 11/30/2015 Due 11/30/2020<br>Int To 05/31/20 on 425,000   | 06/01/20 |                | 3,453.12            |
| US Treasury Note<br>0.125% Dtd 04/15/2016 Due 04/15/2021<br>Treasury Inflation Protection<br>Security<br>Int To 04/15/20 on 98086.50         | 04/15/20 |                | 61.30               |
| US Treasury Note<br>1.125% Dtd 06/30/2016 Due 06/30/2021<br>Int To 06/30/20 on 100,000   | 06/30/20 |                | 562.50              |
| US Treasury Note<br>1.875% Dtd 12/15/2017 Due 12/15/2020<br>Int To 06/15/20 on 220,000   | 06/15/20 |                | 2,062.50            |
| University Calif Revs Gen Rev Bds<br>2015 A Taxable 2.909% Dtd 03/25/2015<br>Due 05/15/2023 Callable<br>Int To 05/15/20 on 135,000           | 05/15/20 |                | 1,963.57            |
| <b>Total Interest Income</b>   |          | <b>\$ 0.00</b> | <b>\$ 54,483.65</b> |
| <b>Purchased Income</b>  |          |                |                     |
| Alabama St GO Ref Bds 2014 A<br>5.00% Dtd 08/06/2014 Due 08/01/2022<br>Non-Callable<br>Accrued Int To 04/29/20 Paid on<br>Purchase of 75,000 | 04/29/20 |                | -916.67             |



**WBSD - OPERATING RESERVE**

Account Number:  
 Statement Period:

04/01/20 -  
 06/30/20

| Income Activity   |          |             |                |
|---|----------|-------------|----------------|
|   | Date     | Income Cash | Principal Cash |
| American Express Co Sr Gbl<br>2.50% Dtd 07/30/2019 Due 07/30/2024<br>Callable<br>Accrued Int To 06/19/20 Paid on<br>Purchase of 100,000                           | 06/19/20 |             | -965.28        |
| Apple Inc Sr Gbl Nt<br>0.75% Dtd 05/11/2020 Due 05/11/2023<br>Callable<br>Accrued Int To 06/02/20 Paid on<br>Purchase of 20,000                                   | 06/02/20 |             | -8.75          |
| Austin Tex Pub Ppty Fin Contractual<br>5.00% Dtd 10/03/2018 Due 11/01/2021<br>Non-Callable<br>Accrued Int To 04/28/20 Paid on<br>Purchase of 85,000               | 04/28/20 |             | -2,089.58      |
| Autozone Inc Sr Gbl<br>2.50% Dtd 04/29/2015 Due 04/15/2021<br>Callable<br>Accrued Int To 05/29/20 Paid on<br>Purchase of 45,000                                   | 05/29/20 |             | -137.50        |
| Bank Amer Chrlt NC MTN Sr Gbl FL Nt<br>Var Rate Dtd 05/24/2019 Due<br>05/24/2021 Callable<br>Accrued Int To 04/21/20 Paid on<br>Purchase of 80,000                | 04/21/20 |             | -257.48        |
| Clackamas Cnty Ore Sch Dist No GO<br>Ref Bds 5.00% Dtd 06/13/2017 Due<br>06/15/2021 Non-Callable<br>Accrued Int To 04/29/20 Paid on<br>Purchase of 75,000         | 04/29/20 |             | -1,395.83      |
| Colorado St Brd Governors Univ Rev<br>Ref Bds 2012b 5.00% Dtd 05/01/2012<br>Due 03/01/2023 Non-Callable<br>Accrued Int To 05/01/20 Paid on<br>Purchase of 125,000 | 05/01/20 |             | -1,041.67      |
| Credit Suisse Ag New York Bran Fr<br>2.80% Dtd 04/09/2020 Due 04/08/2022<br>Non-Callable<br>Accrued Int To 05/29/20 Paid on<br>Purchase of 40,000                 | 05/29/20 |             | -155.56        |



**WBSD - OPERATING RESERVE**

Account Number:  
 Statement Period:

04/01/20 -  
 06/30/20

| Income Activity  |                      |             |                      |
|--|----------------------|-------------|----------------------|
|  | Date                 | Income Cash | Principal Cash       |
| Disney Walt Co Sr Gbl Nt<br>1.65% Dtd 09/06/2019 Due 09/01/2022<br>Callable<br>Accrued Int To 05/29/20 Paid on<br>Purchase of 35,000   | 05/29/20             |             | -141.17              |
| Exxon Mobil Corp Sr Gbl Nt<br>1.902% Dtd 08/16/2019 Due 08/16/2022<br>Callable<br>Accrued Int To 06/02/20 Paid on<br>Purchase of 35,000  | 06/02/20             |             | -196.01              |
| Fyi Pptys Wash Lease Rev Ref Bds<br>5.00% Dtd 03/05/2019 Due 06/01/2021<br>Non-Callable<br>Accrued Int To 04/16/20 Paid on<br>Purchase of 100,000  | 04/16/20             |             | -1,875.00            |
| Harley Davidson Finl Svcs Inc Fr<br>2.55% Dtd 06/09/2017 Due 06/09/2022<br>Callable<br>Accrued Int To 06/19/20 Paid on<br>Purchase of 70,000   | 06/19/20             |             | -49.58               |
| JPMorgan Chase & Co Sr Nt<br>3.25% Dtd 09/24/2012 Due 09/23/2022<br>Non-Callable<br>Accrued Int To 05/29/20 Paid on<br>Purchase of 35,000  | 05/29/20             |             | -208.54              |
| Jackson Cnty MO Reorg Sch Dist GO<br>Sch Bldg Bds 2009c Taxable 4.90% Dtd<br>11/15/2009 Due 03/01/2021 Callable<br>Accrued Int To 04/17/20 Paid on<br>Purchase of 120,000  | 04/17/20             |             | -751.33              |
| League City Tex Combi Tax and Rev<br>Cfs O 5.00% Dtd 07/01/2017 Due<br>02/15/2023 Non-Callable<br>Accrued Int To 05/01/20 Paid on<br>Purchase of 140,000   | 05/01/20             |             | -1,477.78            |
| Los Angeles Calif Mun Impt COR Bds<br>2019a 5.00% Dtd 06/26/2019 Due<br>11/01/2023 Non-Callable<br>Accrued Int To 04/15/20 Paid on<br>Purchase of 60,000<br>Accrued Int To 04/21/20 Paid on<br>Purchase of 5,000 | 04/15/20<br>04/21/20 |             | -1,366.67<br>-118.06 |



**WBSD - OPERATING RESERVE**

**Account Number:**  
**Statement Period:**

**04/01/20 -**  
**06/30/20**

| Income Activity  |          |             |                |
|--|----------|-------------|----------------|
|  | Date     | Income Cash | Principal Cash |
| Morgan Stanley Fr<br>5.75% Dtd 01/25/2011 Due 01/25/2021<br>Callable<br>Accrued Int To 05/29/20 Paid on<br>Purchase of 45,000  | 05/29/20 |             | -891.25        |
| New York N Y GO Bds 2010 D Taxable<br>5.199% Dtd 12/17/2009 Due 12/01/2022<br>Callable<br>Accrued Int To 04/21/20 Paid on<br>Purchase of 10,000                        | 04/21/20 |             | -202.18        |
| Accrued Int To 04/21/20 Paid on<br>Purchase of 50,000  | 04/21/20 |             | -1,010.92      |
| New York St Dorm Auth Revs Non Univ<br>Rev Bds 2019b Taxable 2.839% Dtd<br>02/21/2019 Due 07/01/2022 Callable<br>Accrued Int To 04/17/20 Paid on<br>Purchase of 50,000 | 04/17/20 |             | -417.96        |
| Ohio St Common Schs GO Ref Bds 2016<br>A 5.00% Dtd 03/09/2016 Due<br>12/15/2023 Non-Callable<br>Accrued Int To 04/20/20 Paid on<br>Purchase of 45,000                  | 04/20/20 |             | -781.25        |
| Royal Bk of Cda Bd Cds Fr<br>3.20% Dtd 04/30/2018 Due 04/30/2021<br>Non-Callable<br>Accrued Int To 04/17/20 Paid on<br>Purchase of 5,000                               | 04/17/20 |             | -74.22         |
| Accrued Int To 04/17/20 Paid on<br>Purchase of 19,000  | 04/17/20 |             | -282.04        |
| Accrued Int To 04/17/20 Paid on<br>Purchase of 57,000  | 04/17/20 |             | -846.13        |
| Santa Ana Calif Fing Auth Wtr Ref<br>Bds 5.00% Dtd 08/07/2014 Due<br>09/01/2022 Non-Callable<br>Accrued Int To 04/27/20 Paid on<br>Purchase of 50,000                  | 04/27/20 |             | -388.89        |
| Seattle Wash GO Ref Bds<br>5.00% Dtd 05/16/2012 Due 12/01/2021<br>Non-Callable<br>Accrued Int To 04/30/20 Paid on<br>Purchase of 100,000                               | 04/30/20 |             | -2,069.44      |



**WBSD - OPERATING RESERVE**

Account Number:  
 Statement Period:

04/01/20 -  
 06/30/20

| Income Activity   |          |                |
|---|----------|----------------|
|   | Date     | Principal Cash |
| Small Business Admin Gtd Ln Pool<br>Cffs 2.245% Dtd 09/19/2012 Due<br>09/10/2022<br>Accrued Int To 04/14/20 Paid on<br>Purchase of 219,554.760                            | 04/14/20 | -594.18        |
| Southwest Tex Indpt Sch Dist Ultd<br>Tax Sch Bldg and RE 5.00% Dtd<br>07/15/2014 Due 02/01/2022<br>Non-Callable<br>Accrued Int To 04/29/20 Paid on<br>Purchase of 110,000 | 04/29/20 | -1,344.45      |
| Toronto Dominion Bank Fr<br>2.00% Dtd 01/31/2020 Due 01/31/2023<br>Callable<br>Accrued Int To 04/16/20 Paid on<br>Purchase of 100,000                                     | 04/16/20 | -422.22        |
| Toyota Motor Credit Corp Fr<br>2.90% Dtd 04/01/2020 Due 03/30/2023<br>Non-Callable<br>Accrued Int To 05/29/20 Paid on<br>Purchase of 40,000                               | 05/29/20 | -186.89        |
| Toyota Motor Credit Corp Fr<br>3.00% Dtd 04/01/2020 Due 04/01/2025<br>Callable<br>Accrued Int To 06/19/20 Paid on<br>Purchase of 100,000                                  | 06/19/20 | -650.00        |
| United Parcel Service Inc Sr Nt<br>2.50% Dtd 11/14/2017 Due 04/01/2023<br>Callable<br>Accrued Int To 06/19/20 Paid on<br>Purchase of 90,000                               | 06/19/20 | -487.49        |
| US Treasury Note<br>1.125% Dtd 01/15/2011 Due 01/15/2021<br>Treasury Inflation Protection<br>Security<br>Accrued Int To 04/15/20 Paid on<br>Purchase of 118,079           | 04/15/20 | -332.09        |
| University Calif Revs Gen Rev Bds<br>2015 A Taxable 2.909% Dtd 03/25/2015<br>Due 05/15/2023 Callable<br>Accrued Int To 05/01/20 Paid on<br>Purchase of 135,000            | 05/01/20 | -1,810.85      |



**WBSD - OPERATING RESERVE**

Account Number:  
Statement Period:

04/01/20 -  
06/30/20

| <b>Income Activity</b>   |             |                    |                       |
|--|-------------|--------------------|-----------------------|
|  | <b>Date</b> | <b>Income Cash</b> | <b>Principal Cash</b> |
| Walnut Calif Energy Ctr Auth R Ref<br>Bds 2014a 5.00% Dtd 07/23/2014 Due<br>01/01/2022 Non-Callable<br>Accrued Int To 04/28/20 Paid on<br>Purchase of 65,000 | 04/28/20    |                    | -1,056.25             |
| Washington St Various Purp GO Ref<br>Bds R 5.00% Dtd 07/14/2016 Due<br>08/01/2022 Non-Callable<br>Accrued Int To 04/29/20 Paid on<br>Purchase of 100,000     | 04/29/20    |                    | -1,222.22             |
| Waxahachie Tex Comb Tax Rev Cfts<br>Oblig 5.00% Dtd 09/19/2018 Due<br>08/01/2021 Non-Callable<br>Accrued Int To 04/30/20 Paid on<br>Purchase of 125,000      | 04/30/20    |                    | -1,545.14             |
| <b>Total Purchased Income</b>  |             | <b>\$ 0.00</b>     | <b>\$ -29,768.52</b>  |
| <b>Total Income</b>  |             | <b>\$ 0.00</b>     | <b>\$ 24,715.13</b>   |

| <b>Additions</b>  |             |                    |                        |
|---|-------------|--------------------|------------------------|
|   | <b>Date</b> | <b>Income Cash</b> | <b>Principal Cash</b>  |
| <b>Miscellaneous Additions</b>  |             |                    |                        |
| Addition To Account<br>ACH Transfer From Bank of The West<br>Ckg Ending In 6049 Per<br>Instruction 4/8/20 | 04/10/20    |                    | 1,300,000.00           |
| <b>Total Miscellaneous Additions</b>  |             | <b>\$ 0.00</b>     | <b>\$ 1,300,000.00</b> |
| <b>Total Additions</b>  |             | <b>\$ 0.00</b>     | <b>\$ 1,300,000.00</b> |

| <b>Disbursement Activity</b> |             |                    |                       |
|------------------------------|-------------|--------------------|-----------------------|
|                              | <b>Date</b> | <b>Income Cash</b> | <b>Principal Cash</b> |
| <b>Fees/Expenses</b>         |             |                    |                       |
| Monthly Fee To 03/31/20      | 04/15/20    |                    | -1,431.03             |
| Monthly Fee To 04/30/20      | 05/15/20    |                    | -1,603.16             |



**WBSD - OPERATING RESERVE**

Account Number:  
Statement Period:

04/01/20 -  
06/30/20

| Disbursement Activity      |          |                |                     |
|----------------------------|----------|----------------|---------------------|
|                            | Date     | Income Cash    | Principal Cash      |
| Monthly Fee To 05/31/20    | 06/15/20 |                | -1,606.28           |
| <b>Total Fees/Expenses</b> |          | <b>\$ 0.00</b> | <b>\$ -4,640.47</b> |
| <b>Total Disbursements</b> |          | <b>\$ 0.00</b> | <b>\$ -4,640.47</b> |

| Purchase Activity   |          |             |                |
|---|----------|-------------|----------------|
|   | Date     | Income Cash | Principal Cash |
| Bank of The West Advantage Acct<br>Purchases (19) 04/01/20 To 06/30/20  | 06/30/20 |             | -2,353,620.96  |
| Alabama St GO Ref Bds 2014 A<br>5.00% Dtd 08/06/2014 Due 08/01/2022<br>Non-Callable<br>Purchased 75000 04/27/20<br>From Piper & Jaffray & Co<br>@ 108.616         | 04/29/20 |             | -81,462.00     |
| American Express Co Sr Gbl<br>2.50% Dtd 07/30/2019 Due 07/30/2024<br>Callable<br>Purchased 100000 06/17/20<br>From BNY Mellon/Toronto Dominion Sec<br>@ 105.752   | 06/19/20 |             | -105,752.00    |
| Apple Inc Sr Gbl Nt<br>0.75% Dtd 05/11/2020 Due 05/11/2023<br>Callable<br>Purchased 20000 05/29/20<br>From BNY Mellon/Toronto Dominion Sec<br>@ 101.187           | 06/02/20 |             | -20,237.40     |
| Austin Tex Pub Ppty Fin Contractual<br>5.00% Dtd 10/03/2018 Due 11/01/2021<br>Non-Callable<br>Purchased 85000 04/24/20<br>From Samco Capital Markets<br>@ 105.895 | 04/28/20 |             | -90,010.75     |
| Autozone Inc Sr Gbl<br>2.50% Dtd 04/29/2015 Due 04/15/2021<br>Callable<br>Purchased 45000 05/27/20<br>From BNY Mellon/Toronto Dominion Sec<br>@ 101.342           | 05/29/20 |             | -45,603.90     |



**WBSD - OPERATING RESERVE**

Account Number:  
 Statement Period:

04/01/20 -  
 06/30/20

| Purchase Activity  |          |                |
|--|----------|----------------|
|  | Date     | Principal Cash |
| Bank Amer Chrlt NC MTN Sr Gbl FL Nt<br>Var Rate Dtd 05/24/2019 Due<br>05/24/2021 Callable<br>Purchased 80000 04/17/20<br>From BNY Mellon/Toronto Dominion Sec<br>@ 99.653      | 04/21/20 | -79,722.40     |
| Clackamas Cnty Ore Sch Dist No GO<br>Ref Bds 5.00% Dtd 06/13/2017 Due<br>06/15/2021 Non-Callable<br>Purchased 75000 04/27/20<br>From Tmc Bonds LLC<br>@ 104.381                | 04/29/20 | -78,285.75     |
| Colorado St Brd Governors Univ Rev<br>Ref Bds 2012b 5.00% Dtd 05/01/2012<br>Due 03/01/2023 Non-Callable<br>Purchased 125000 04/29/20<br>From Southwest Securities<br>@ 110.258 | 05/01/20 | -137,822.50    |
| Credit Suisse Ag New York Bran Fr<br>2.80% Dtd 04/09/2020 Due 04/08/2022<br>Non-Callable<br>Purchased 40000 05/27/20<br>From BNY Mellon/Toronto Dominion Sec<br>@ 103.644      | 05/29/20 | -41,457.60     |
| Disney Walt Co Sr Gbl Nt<br>1.65% Dtd 09/06/2019 Due 09/01/2022<br>Callable<br>Purchased 35000 05/27/20<br>From BNY Mellon/Toronto Dominion Sec<br>@ 102.122                   | 05/29/20 | -35,742.70     |
| Exxon Mobil Corp Sr Gbl Nt<br>1.902% Dtd 08/16/2019 Due 08/16/2022<br>Callable<br>Purchased 35000 05/29/20<br>From BNY Mellon/Toronto Dominion Sec<br>@ 103.201                | 06/02/20 | -36,120.35     |
| Fyi Pptys Wash Lease Rev Ref Bds<br>5.00% Dtd 03/05/2019 Due 06/01/2021<br>Non-Callable<br>Purchased 100000 04/14/20<br>From D A Davidson & Co<br>@ 103.934                    | 04/16/20 | -103,934.00    |





**WBSD - OPERATING RESERVE**

Account Number:  
 Statement Period:

04/01/20 -  
 06/30/20

| Purchase Activity   |          |                |
|---|----------|----------------|
|   | Date     | Principal Cash |
| Harley Davidson Finl Svcs Inc Fr<br>2.55% Dtd 06/09/2017 Due 06/09/2022<br>Callable<br>Purchased 70000 06/17/20<br>From BNY Mellon/Toronto Dominion Sec<br>@ 100.65                   | 06/19/20 | -70,455.00     |
| JPMorgan Chase & Co Sr Nt<br>3.25% Dtd 09/24/2012 Due 09/23/2022<br>Non-Callable<br>Purchased 35000 05/27/20<br>From BNY Mellon/Toronto Dominion Sec<br>@ 105.375                     | 05/29/20 | -36,881.25     |
| Jackson Cnty MO Reorg Sch Dist GO<br>Sch Bldg Bds 2009c Taxable 4.90% Dtd<br>11/15/2009 Due 03/01/2021 Callable<br>Purchased 120000 04/15/20<br>From Wedbush Morgan Secs<br>@ 102.818 | 04/17/20 | -123,381.60    |
| LA Canada Calif Uni Sch Dist Taxable<br>GO Ref Bds Taxable 1.55% Dtd<br>04/28/2020 Due 08/01/2022<br>Non-Callable<br>Purchased 30000 04/14/20<br>From Stifel Nicolaus & Co<br>@ 100   | 04/28/20 | -30,000.00     |
| LA Canada Calif Uni Sch Dist Taxable<br>GO Ref Bds Taxable 1.65% Dtd<br>04/28/2020 Due 08/01/2023<br>Non-Callable<br>Purchased 60000 04/14/20<br>From Stifel Nicolaus & Co<br>@ 100   | 04/28/20 | -60,000.00     |
| League City Tex Combi Tax and Rev<br>Ctfs O 5.00% Dtd 07/01/2017 Due<br>02/15/2023 Non-Callable<br>Purchased 140000 04/29/20<br>From BOK Financial Securities, Inc.<br>@ 110.244      | 05/01/20 | -154,341.60    |
| Los Angeles Calif Mun Impt COR Bds<br>2019a 5.00% Dtd 06/26/2019 Due<br>11/01/2023 Non-Callable<br>Purchased 60000 04/13/20<br>From D A Davidson & Co<br>@ 112.036                    | 04/15/20 | -67,221.60     |



**WBSD - OPERATING RESERVE**

**Account Number:**  
**Statement Period:**

**04/01/20 -**  
**06/30/20**

| Purchase Activity   |          |             |                |
|---|----------|-------------|----------------|
|   | Date     | Income Cash | Principal Cash |
| Purchased 5000 04/17/20<br>From Headlands Holdings LLC<br>@ 112.312   | 04/21/20 |             | -5,615.60      |
| Morgan Stanley Fr<br>5.75% Dtd 01/25/2011 Due 01/25/2021<br>Callable<br>Purchased 45000 05/27/20<br>From BNY Mellon/Toronto Dominion Sec<br>@ 103.396                                 | 05/29/20 |             | -46,528.20     |
| New York N Y GO Bds 2010 D Taxable<br>5.199% Dtd 12/17/2009 Due 12/01/2022<br>Callable<br>Purchased 10000 04/17/20<br>From Tmc Bonds LLC<br>@ 108.757                                 | 04/21/20 |             | -10,875.70     |
| Purchased 50000 04/17/20<br>From Morgan Stanley & Co<br>@ 109.462   | 04/21/20 |             | -54,731.00     |
| New York St Dorm Auth Revs Non Univ<br>Rev Bds 2019b Taxable 2.839% Dtd<br>02/21/2019 Due 07/01/2022 Callable<br>Purchased 50000 04/15/20<br>From Headlands Holdings LLC<br>@ 102.432 | 04/17/20 |             | -51,216.00     |
| Ohio St Common Schs GO Ref Bds 2016<br>A 5.00% Dtd 03/09/2016 Due<br>12/15/2023 Non-Callable<br>Purchased 45000 04/16/20<br>From BOK Financial Securities, Inc.<br>@ 113.003          | 04/20/20 |             | -50,851.35     |
| Royal Bk of Cda Bd Cds Fr<br>3.20% Dtd 04/30/2018 Due 04/30/2021<br>Non-Callable<br>Purchased 5000 04/15/20<br>From Tmc Bonds LLC<br>@ 101.9  | 04/17/20 |             | -5,095.00      |
| Purchased 19000 04/15/20<br>From Tmc Bonds LLC<br>@ 102.058   | 04/17/20 |             | -19,391.02     |
| Purchased 57000 04/15/20<br>From Tmc Bonds LLC<br>@ 102.068   | 04/17/20 |             | -58,178.76     |



**WBSD - OPERATING RESERVE**

Account Number:  
 Statement Period:

04/01/20 -  
 06/30/20

| Purchase Activity   |          |                |
|---|----------|----------------|
|   | Date     | Principal Cash |
| Santa Ana Calif Fing Auth Wtr Ref<br>Bds 5.00% Dtd 08/07/2014 Due<br>09/01/2022 Non-Callable<br>Purchased 50000 04/23/20<br>From BOK Financial Securities, Inc.<br>@ 108.031            | 04/27/20 | -54,015.50     |
| Seattle Wash GO Ref Bds<br>5.00% Dtd 05/16/2012 Due 12/01/2021<br>Non-Callable<br>Purchased 100000 04/28/20<br>From Tmc Bonds LLC<br>@ 106.114  | 04/30/20 | -106,114.00    |
| Small Business Admin Gtd Ln Pool<br>Cfs 2.245% Dtd 09/19/2012 Due<br>09/10/2022<br>Purchased 219554.760 04/08/20<br>From Piper & Jaffray & Co<br>@ 101.285156                           | 04/14/20 | -222,376.38    |
| Southwest Tex Indpt Sch Dist Ultd<br>Tax Sch Bldg and RE 5.00% Dtd<br>07/15/2014 Due 02/01/2022<br>Non-Callable<br>Purchased 110000 04/27/20<br>From Samco Capital Markets<br>@ 106.851 | 04/29/20 | -117,536.10    |
| Toronto Dominion Bank Fr<br>2.00% Dtd 01/31/2020 Due 01/31/2023<br>Callable<br>Purchased 100000 04/14/20<br>From BOK Financial Securities, Inc.<br>@ 99.756                             | 04/16/20 | -99,756.00     |
| Toyota Motor Credit Corp Fr<br>2.90% Dtd 04/01/2020 Due 03/30/2023<br>Non-Callable<br>Purchased 40000 05/27/20<br>From BNY Mellon/Toronto Dominion Sec<br>@ 105.394                     | 05/29/20 | -42,157.60     |
| Toyota Motor Credit Corp Fr<br>3.00% Dtd 04/01/2020 Due 04/01/2025<br>Callable<br>Purchased 100000 06/17/20<br>From BNY Mellon/Toronto Dominion Sec<br>@ 109.863                        | 06/19/20 | -109,863.00    |



**WBSD - OPERATING RESERVE**

Account Number:  
 Statement Period:

04/01/20 -  
 06/30/20

| Purchase Activity   |          |                         |
|---|----------|-------------------------|
|   | Date     | Principal Cash          |
| United Parcel Service Inc Sr Nt<br>2.50% Dtd 11/14/2017 Due 04/01/2023<br>Callable<br>Purchased 90000 06/17/20<br>From BNY Mellon/Toronto Dominion Sec<br>@ 105.153                   | 06/19/20 | -94,637.70              |
| US Treasury Note<br>1.125% Dtd 01/15/2011 Due 01/15/2021<br>Treasury Inflation Protection<br>Security<br>Purchased 118079 04/14/20<br>From Wells Fargo Securities, LLC<br>@ 99.464844 | 04/15/20 | -117,447.09             |
| University Calif Revs Gen Rev Bds<br>2015 A Taxable 2.909% Dtd 03/25/2015<br>Due 05/15/2023 Callable<br>Purchased 135000 04/29/20<br>From Wells Fargo Securities, LLC<br>@ 104.778    | 05/01/20 | -141,450.30             |
| Walnut Calif Energy Ctr Auth R Ref<br>Bds 2014a 5.00% Dtd 07/23/2014 Due<br>01/01/2022 Non-Callable<br>Purchased 65000 04/24/20<br>From D A Davidson & Co<br>@ 106.109                | 04/28/20 | -68,970.85              |
| Washington St Various Purp GO Ref<br>Bds R 5.00% Dtd 07/14/2016 Due<br>08/01/2022 Non-Callable<br>Purchased 100000 04/27/20<br>From Samco Capital Markets<br>@ 108.78                 | 04/29/20 | -108,780.00             |
| Waxahachie Tex Comb Tax Rev Cfts<br>Oblig 5.00% Dtd 09/19/2018 Due<br>08/01/2021 Non-Callable<br>Purchased 125000 04/28/20<br>From BOK Financial Securities, Inc.<br>@ 104.773        | 04/30/20 | -130,966.25             |
| <b>Total Purchases</b>  |          | <b>\$ -5,468,606.76</b> |
|   |          | <b>\$ 0.00</b>          |



**WBSD - OPERATING RESERVE**

**Account Number:**  
**Statement Period:**

**04/01/20 -**  
**06/30/20**

| Sale Activity  |          |              |                    |
|--|----------|--------------|--------------------|
|  | Date     | Proceeds     | Realized Gain/Loss |
| Bank of The West Advantage Acct<br>Sales (16) 04/01/20 To 06/30/20   | 06/30/20 | 3,035,856.19 |                    |
| Bank Amer Chrlt NC MTN Sr Gbl FL Nt<br>Var Rate Dtd 05/24/2019 Due<br>05/24/2021 Callable<br>Full Call @ 100 on 5/26/2020<br>80,000 Par Value    | 05/26/20 | 80,000.00    | 253.48             |
| Constellation Brands Inc Sr Gbl Nt<br>2.25% Dtd 11/07/2017 Due 11/06/2020<br>Callable<br>Recd Proceeds on Full Call of<br>75,000 Par Value       | 05/27/20 | 75,660.49    | 835.99             |
| Federal Home Ln Mtg Corp Partn Gold<br>Group #G13107 5.500% Dtd 03/01/2008<br>Due 07/01/2020 IPD14<br>Prin Pmt For March 2020                    | 04/15/20 | 15.16        | -0.77              |
| Prin Pmt For April 2020  | 05/15/20 | 0.94         | -0.05              |
| Recd Proceeds on Final Paydown of  | 06/15/20 | 0.47         | -0.02              |
| Federal Home Ln Mtg Corp Partn Gold<br>Group #G11940 5.500% Dtd 03/01/2006<br>Due 05/01/2020 IPD14<br>Prin Pmt For March 2020                    | 04/15/20 | 25.50        | -1.40              |
| Recd Proceeds on Final Paydown of  | 05/15/20 | 14.70        | -0.81              |
| Federal Farm Cr Bks Cons Systemwide<br>Bds 1.64% Dtd 12/11/2019 Due<br>06/11/2021 Callable<br>Recd Proceeds on Full Call of<br>100,000 Par Value | 04/01/20 | 100,000.00   |                    |
| Federal Home Loan Bks Cons Bds<br>4.625% Dtd 05/25/2005 Due 06/12/2020<br>Non-Callable<br>Recd Proceeds on Maturity of<br>200,000 Par Value      | 06/12/20 | 200,000.00   |                    |
| Federal Home Loan Bks Cons Bds<br>1.75% Dtd 06/03/2013 Due 06/12/2020<br>Non-Callable<br>Recd Proceeds on Maturity of<br>60,000 Par Value        | 06/12/20 | 60,000.00    |                    |
| Federal Home Ln Mtg Corp<br>1.60% Dtd 05/15/2017 Due 05/15/2020<br>Callable<br>Recd Proceeds on Maturity of<br>240,000 Par Value                 | 05/15/20 | 240,000.00   |                    |



**WBSD - OPERATING RESERVE**

Account Number:  
 Statement Period:

04/01/20 -  
 06/30/20

| Sale Activity  |                                  |                                  |                         |
|--|----------------------------------|----------------------------------|-------------------------|
|  | Date                             | Proceeds                         | Realized Gain/Loss      |
| Federal Home Ln Mtg Corp<br>1.65% Dtd 01/27/2020 Due 04/27/2022<br>Callable<br>Recd Proceeds on Full Call of<br>100,000 Par Value                              | 04/27/20                         | 100,000.00                       | 10.00                   |
| Federal Natl Mtg Assn<br>1.80% Dtd 10/26/2012 Due 10/26/2021<br>Callable<br>Recd Proceeds on Full Call of<br>200,000 Par Value                                 | 06/26/20                         | 200,000.00                       |                         |
| Federal Home Ln Mtg Corp<br>1.375% Dtd 04/04/2013 Due 05/01/2020<br>Non-Callable<br>Recd Proceeds on Maturity of<br>50,000 Par Value                           | 05/01/20                         | 50,000.00                        |                         |
| Federal Natl Mtg Assn Gtd Passthru<br>CTF Pool #797828 5.000% Dtd<br>04/01/2005 Due 04/01/2020 IPD24<br>Recd Proceeds At Final Paydown of                      | 04/27/20                         | 59.68                            | -3.32                   |
| Ncua Guaran Nts Tr Ser 2010 R1 Cl I<br>A Fltg Rate Dtd 10/27/2010 Due<br>10/07/2020<br>Prin Pmt For 04/06/20<br>Prin Pmt For 05/07/20<br>Prin Pmt For 06/05/20 | 04/06/20<br>05/08/20<br>06/05/20 | 2,485.53<br>2,014.95<br>2,398.49 | -6.21<br>-5.04<br>-6.00 |
| <b>Total Sales</b>   |                                  | <b>\$ 4,148,532.10</b>           | <b>\$ 1,075.85</b>      |

| Non-Cash Activity   |                      |               |
|---|----------------------|---------------|
|   | Date                 | Cost          |
| Austin Tex Pub Ppty Fin Contractual<br>5.00% Dtd 10/03/2018 Due 11/01/2021<br>Non-Callable<br>Amortization of Premium                       | 05/01/20             | -27.20        |
| Bank Amer Chrlt NC MTN Sr Gbl FL Nt<br>Var Rate Dtd 05/24/2019 Due<br>05/24/2021 Callable<br>Accretion of Discount<br>Accretion of Discount | 04/30/20<br>05/26/20 | 6.35<br>17.77 |
| Clackamas Cnty Ore Sch Dist No GO<br>Ref Bds 5.00% Dtd 06/13/2017 Due<br>06/15/2021 Non-Callable<br>Amortization of Premium                 | 06/15/20             | -362.25       |



**WBSD - OPERATING RESERVE**

Account Number:  
 Statement Period:

0 04/01/20 -  
 06/30/20

**Non-Cash Activity**

|   | Date     | Cost      |
|---|----------|-----------|
| Fyi Pptys Wash Lease Rev Ref Bds<br>5.00% Dtd 03/05/2019 Due 06/01/2021<br>Non-Callable<br>Amortization of Premium        | 06/01/20 | -433.00   |
| Federal Home Loan Bks Cons Bds<br>1.875% Dtd 11/30/2016 Due 11/29/2021<br>Non-Callable<br>Accretion of Discount           | 05/29/20 | 392.23    |
| Federal Farm Cr Bks Cons Systemwide<br>Bds 2.40% Dtd 06/17/2015 Due<br>06/17/2022 Non-Callable<br>Amortization of Premium | 06/17/20 | -697.95   |
| Federal Home Loan Bks Cons Bds<br>4.625% Dtd 05/25/2005 Due 06/12/2020<br>Non-Callable<br>Amortization of Premium         | 06/12/20 | -3,046.00 |
| Federal Home Loan Bks Cons Bds<br>1.75% Dtd 06/03/2013 Due 06/12/2020<br>Non-Callable<br>Amortization of Premium          | 06/12/20 | -70.20    |
| Federal Natl Mtg Assn<br>1.50% Dtd 10/19/2015 Due 11/30/2020<br>Non-Callable<br>Accretion of Discount                     | 04/30/20 | 11.80     |
| Accretion of Discount   | 05/29/20 | 11.80     |
| Accretion of Discount   | 06/30/20 | 11.80     |
| Federal Natl Mtg Assn<br>1.875% Dtd 11/16/2015 Due 12/28/2020<br>Non-Callable<br>Amortization of Premium                  | 06/26/20 | -190.80   |
| Federal Natl Mtg Assn<br>1.375% Dtd 02/05/2016 Due 02/26/2021<br>Non-Callable<br>Accretion of Discount                    | 04/30/20 | 21.38     |
| Accretion of Discount   | 05/29/20 | 21.38     |
| Accretion of Discount   | 06/30/20 | 21.38     |
| Federal Natl Mtg Assn<br>1.25% Dtd 05/16/2016 Due 05/06/2021<br>Non-Callable<br>Accretion of Discount                     | 04/30/20 | 43.35     |
| Accretion of Discount   | 05/29/20 | 43.35     |
| Accretion of Discount   | 06/30/20 | 43.35     |



**WBSD - OPERATING RESERVE**

Account Number:  
 Statement Period:

04/01/20 -  
 06/30/20

**Non-Cash Activity**

|   | Date     | Cost    |
|---|----------|---------|
| Federal Natl Mtg Assn<br>1.375% Dtd 10/07/2016 Due 10/07/2021<br>Non-Callable                   |          |         |
| Accretion of Discount   | 04/30/20 | 25.07   |
| Accretion of Discount   | 05/29/20 | 25.07   |
| Accretion of Discount   | 06/30/20 | 25.07   |
| Federal Natl Mtg Assn<br>2.00% Dtd 01/09/2017 Due 01/05/2022<br>Non-Callable                    |          |         |
| Accretion of Discount   | 04/30/20 | 45.06   |
| Accretion of Discount   | 05/29/20 | 45.06   |
| Accretion of Discount   | 06/30/20 | 45.06   |
| Federal Natl Mtg Assn<br>1.875% Dtd 04/10/2017 Due 04/05/2022<br>Non-Callable                   |          |         |
| Amortization of Premium   | 04/03/20 | -176.00 |
| Federal Home Ln Mtg Corp<br>1.375% Dtd 04/04/2013 Due 05/01/2020<br>Non-Callable                |          |         |
| Accretion of Discount   | 04/30/20 | 9.74    |
| Accretion of Discount   | 05/01/20 | 0.56    |
| GE Capital Internotes Fr<br>5.50% Dtd 11/05/2009 Due 11/15/2021<br>Non-Callable                 |          |         |
| Amortization of Premium   | 05/15/20 | -744.50 |
| Los Angeles Calif Mun Impt COR Bds<br>2019a 5.00% Dtd 06/26/2019 Due<br>11/01/2023 Non-Callable |          |         |
| Amortization of Premium   | 05/01/20 | -87.60  |
| Amortization of Premium   | 05/01/20 | -4.70   |
| Michigan St GO Ref Bds 2009a Taxable<br>6.95% Dtd 04/14/2009 Due 11/01/2020<br>Non-Callable     |          |         |
| Amortization of Premium   | 05/01/20 | -408.75 |
| New York N Y GO Bds 2010 D Taxable<br>5.199% Dtd 12/17/2009 Due 12/01/2022<br>Callable          |          |         |
| Amortization of Premium   | 06/01/20 | -36.20  |
| Amortization of Premium   | 06/01/20 | -197.00 |
| Ohio St Common Schs GO Ref Bds 2016<br>A 5.00% Dtd 03/09/2016 Due<br>12/15/2023 Non-Callable    |          |         |
| Amortization of Premium   | 06/15/20 | -238.50 |





**WBSD - OPERATING RESERVE**

**Account Number:**  
**Statement Period:**

**0 04/01/20 -**  
**06/30/20**

**Non-Cash Activity**

|   | <b>Date</b> | <b>Cost</b> |
|---|-------------|-------------|
| Royal Bk of Cda Bd Cds Fr<br>3.20% Dtd 04/30/2018 Due 04/30/2021<br>Non-Callable                      |             |             |
| Amortization of Premium   | 04/30/20    | -3.25       |
| Amortization of Premium   | 04/30/20    | -13.49      |
| Amortization of Premium   | 04/30/20    | -40.47      |
| Seattle Wash GO Ref Bds<br>5.00% Dtd 05/16/2012 Due 12/01/2021<br>Non-Callable                        |             |             |
| Amortization of Premium   | 06/01/20    | -328.00     |
| 3M Co Fr<br>2.00% Dtd 06/26/2012 Due 06/26/2022<br>Non-Callable                                       |             |             |
| Accretion of Discount   | 04/30/20    | 22.27       |
| Accretion of Discount   | 05/29/20    | 22.27       |
| Accretion of Discount   | 06/30/20    | 22.27       |
| US Treasury Note<br>1.625% Dtd 11/30/2015 Due 11/30/2020  |             |             |
| Accretion of Discount   | 05/29/20    | 1,012.55    |
| Accretion of Discount   | 05/29/20    | 867.90      |
| Amortization of Premium   | 05/29/20    | -18.60      |
| US Treasury Note<br>1.125% Dtd 01/15/2011 Due 01/15/2021<br>Treasury Inflation Protection<br>Security |             |             |
| Inflationary Int Adjustment   | 04/29/20    | 162.00      |
| Inflationary Int Adjustment   | 05/14/20    | -106.00     |
| Inflationary Int Adjustment   | 05/28/20    | -133.00     |
| Inflationary Int Adjustment   | 06/12/20    | -376.00     |
| Inflationary Int Adjustment   | 06/30/20    | -395.00     |
| US Treasury Note<br>0.125% Dtd 04/15/2016 Due 04/15/2021<br>Treasury Inflation Protection<br>Security |             |             |
| Inflationary Int Adjustment   | 04/14/20    | 137.70      |
| Inflationary Int Adjustment   | 04/29/20    | 134.10      |
| Inflationary Int Adjustment   | 05/14/20    | -88.20      |
| Inflationary Int Adjustment   | 05/28/20    | -109.80     |
| Inflationary Int Adjustment   | 06/12/20    | -313.20     |
| Inflationary Int Adjustment   | 06/30/20    | -327.60     |
| US Treasury Note<br>1.125% Dtd 06/30/2016 Due 06/30/2021  |             |             |
| Amortization of Premium   | 06/30/20    | -111.97     |



**WBSD - OPERATING RESERVE**

Account Number:  
 Statement Period:

04/01/20 -  
 06/30/20

| Non-Cash Activity   |          |                     |
|---|----------|---------------------|
|   | Date     | Cost                |
| US Treasury Note<br>1.875% Dtd 12/15/2017 Due 12/15/2020<br>Amortization of Premium   | 06/15/20 | -644.73             |
| University Calif Revs Gen Rev Bds<br>2015 A Taxable 2.909% Dtd 03/25/2015<br>Due 05/15/2023 Callable<br>Amortization of Premium | 05/15/20 | -79.65              |
| <b>Total Non-Cash Transactions</b>  |          | <b>\$ -6,561.92</b> |

SECURITY PRICES CONTAINED IN THIS STATEMENT ARE OBTAINED FROM THE MOST RELIABLE SOURCES AVAILABLE BUT ARE NOT GUARANTEED BY BANK OF THE WEST. QUOTED PRICES MAY NOT EQUAL ACTUAL PRICES BECAUSE OF SECURITY SIZE, MARKET PRICE, TERM AND DEMAND.



## **Electronic Funds Transfers**

### Preauthorized Transfers:

You may request an electronic fund transfer (EFT), such as an ACH transfer from or deposit to your account, by contacting your account Administrator. You may also preauthorize periodic EFTs by contacting your account Administrator. If you would like to know whether a preauthorized EFT has occurred, please contact your account Administrator at the phone number listed on the first page of your statement, or call 1-877-898-1003 (TTY 1-800-659-5495) between the hours of 8:00 A.M. to 5:00 P.M. Pacific Standard Time.

### Error Resolution Notice:

If you think a statement or receipt is wrong or if you need more information about an EFT listed on a statement or receipt, telephone us at 1-877-898-1003 (TTY 1-800-659-5495) between the hours of 8:00 A.M. to 5:00 P.M. Pacific Standard Time, write to us at Bank of the West, 13300 Crossroads Parkway North, City of Industry, CA 91746, or e-mail us at [WMGIFSOperations@bankofthewest.com](mailto:WMGIFSOperations@bankofthewest.com) as soon as possible. We must hear from you no later than 60 days after we sent the FIRST statement on which the problem or error appeared.

1. Tell us your name and account number (if any).
2. Tell us the dollar amount of the suspected error.
3. Describe the error or the transfer you are unsure about, and explain as clearly as you can why you believe it is an error or why you need more information.

If you contact us verbally, we may require that you send us your complaint or question in writing within 10 business days. We will investigate your complaint and will correct any error promptly. If we take more than 10 business days to do this, we will credit your account for the amount you think is in error, so that you will have the use of the money during the time it takes us to complete our investigation.



**WBSD - RATE STABILIZATION RESERVE**

Account Number:  
 Statement Period:

04/01/20 -  
 06/30/20

WEST BAY SANITARY DISTRICT  
 RATE STABILIZATION RESERVE  
 500 LAUREL STREET  
 MENLO PARK CA 94025

**Fiduciary**  
 Chuen Ying Lee  
 (408) 645-3234  
**Portfolio**  
 Michael D. Smith  
 (408) 490-2079

**Asset Allocation**

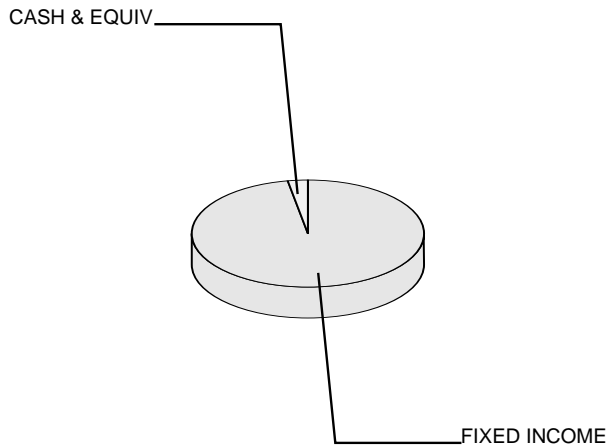

**Asset Valuation**

| Description            | Market Value           | % of Account  |
|------------------------|------------------------|---------------|
| Cash & Equiv           | 37,648.63              | 2.7%          |
| Fixed Income           | 1,353,305.70           | 97.3%         |
| <b>Total Portfolio</b> | <b>\$ 1,390,954.33</b> | <b>100.0%</b> |
| Accrued Income         | 17,452.93              |               |
| <b>Total Valuation</b> | <b>\$ 1,408,407.26</b> |               |

**Market Reconciliation**

|   | Current Period         | Year To Date           |
|---|------------------------|------------------------|
| <b>Beginning Market Value</b>                     | <b>\$ 1,403,292.32</b> | <b>\$ 6,081,980.07</b> |
| Income  |                        |                        |
| Interest.....                                     | 3,402.41               | 96,208.60              |
| Purchased Income.....                             | -764.73                | -1,434.96              |
| Disbursements.....                                | -719.15                | -1,560,828.23          |
| Cash Transfers.....                               | 0.00                   | -17,700.00             |
| Realized Gains/(Losses).....                      | 0.00                   | -5,003.35              |
| Change In Accrued Income.....                     | 8,915.71               | -26,517.32             |
| Change In Market Appreciation/(Depreciation)..... | -6,417.20              | 24,869.03              |
| Non-Cash Asset Changes.....                       | 697.90                 | -3,183,166.58          |
| <b>Ending Market Value</b>                        | <b>\$ 1,408,407.26</b> | <b>\$ 1,408,407.26</b> |



**WBSD - RATE STABILIZATION RESERVE**

Account Number:  
Statement Period:

04/01/20 -  
06/30/20

**Asset Position As of 06/30/20**

| Asset Description   | Units       | Market Value<br>Cost                       | Est. Annual Income<br>Accruals | Current<br>Yield |
|---|-------------|--|--------------------------------|------------------|
| <b>Cash Equivalents</b>   |             |  |                                |                  |
| Bank of The West Advantage Acct   | 37,648.630  | 37,648.63<br>37,648.63                     | 45.00<br>2.34                  | 0.12%            |
| <b>Total Cash Equivalents</b>   |             | <b>\$ 37,648.63</b><br><b>\$ 37,648.63</b> | <b>45.00</b><br><b>2.34</b>    | <b>0.12%</b>     |
| <b>Fixed Income</b>   |             |  |                                |                  |
| Apple Inc Sr Glbl Nt<br>0.75% Dtd 05/11/2020 Due 05/11/2023<br>Callable   | 20,000.000  | 20,210.80<br>20,237.40                     | 150.00<br>20.83                | 0.74%            |
| Citibank NA N Y<br>2.85% Dtd 02/15/2018 Due 02/12/2021<br>Callable  | 60,000.000  | 60,779.40<br>60,498.00                     | 1,710.00<br>660.25             | 2.81%            |
| Clemson Univ S C Univ Revs Athletic<br>Facs Rev Bds 2.00% Dtd 02/01/2012<br>Due 05/01/2022 Non-Callable                     | 45,000.000  | 46,311.75<br>45,441.45                     | 900.00<br>150.00               | 1.94%            |
| Federal Farm Cr Bks Cons Systemwide<br>Bds 1.90% Dtd 07/19/2017 Due<br>07/19/2022 Non-Callable                              | 80,000.000  | 82,696.00<br>80,194.40                     | 1,520.00<br>683.99             | 1.84%            |
| Federal Farm Cr Bks Cons Systemwide<br>Bds 1.90% Dtd 08/03/2017 Due<br>08/03/2022 Non-Callable                              | 85,000.000  | 87,913.80<br>85,113.05                     | 1,615.00<br>663.94             | 1.84%            |
| Federal Natl Mtg Assn<br>1.875% Dtd 04/10/2017 Due 04/05/2022<br>Non-Callable   | 95,000.000  | 97,820.55<br>95,161.50                     | 1,781.00<br>425.52             | 1.82%            |
| Silicon Vy Clean Wtr Calif Was Rev<br>Bds 5.00% Dtd 11/24/2015 Due<br>08/01/2020 Non-Callable<br>--- 650,000 Restricted --- | 650,000.000 | 652,535.00<br>662,537.50                   | 32,500.00<br>13,541.66         | 4.98%            |
| Toyota Motor Credit Corp Fr<br>2.90% Dtd 04/01/2020 Due 03/30/2023<br>Non-Callable  | 10,000.000  | 10,586.50<br>10,539.40                     | 290.00<br>72.50                | 2.74%            |
| US Treasury Note<br>1.625% Dtd 11/30/2015 Due 11/30/2020  | 150,000.000 | 150,885.00<br>149,132.09                   | 2,437.00<br>206.45             | 1.62%            |
| US Treasury Note<br>0.125% Dtd 04/15/2016 Due 04/15/2021<br>Treasury Inflation Protection<br>Security                       | 10,820.200  | 10,871.70<br>10,793.92                     | 13.00<br>2.86                  | 0.12%            |



**WBSD - RATE STABILIZATION RESERVE**

Account Number:  
 Statement Period:

04/01/20 -  
 06/30/20

**Asset Position As of 06/30/20**

| Asset Description  | Units      | Market Value Cost                                | Est. Annual Income Accruals          | Current Yield |
|--|------------|--|--------------------------------------|---------------|
| US Treasury Note<br>1.875% Dtd 12/15/2017 Due 12/15/2020 | 20,000.000 | 20,155.80<br>20,104.67                           | 375.00<br>16.39                      | 1.86%         |
| US Treasury Note<br>2.75% Dtd 09/15/2018 Due 09/15/2021  | 60,000.000 | 61,868.40<br>59,817.19                           | 1,650.00<br>484.23                   | 2.67%         |
| US Treasury Note<br>2.50% Dtd 01/31/2019 Due 01/31/2021  | 50,000.000 | 50,671.00<br>50,416.82                           | 1,250.00<br>521.97                   | 2.47%         |
| <b>Total Fixed Income</b>                                |            | <b>\$ 1,353,305.70</b><br><b>\$ 1,349,987.39</b> | <b>46,191.00</b><br><b>17,450.59</b> | <b>3.41%</b>  |
| <b>Cash</b>  |            |  |                                      |               |
| Principal Cash   |            | 0.00<br>0.00                                     | 0.00                                 | 0.00%         |
| Income Cash  |            | 0.00<br>0.00                                     | 0.00                                 | 0.00%         |
| <b>Total Cash</b>  |            | <b>\$ 0.00</b><br><b>\$ 0.00</b>                 | <b>0.00</b><br><b>0.00</b>           | <b>0.00%</b>  |
| <b>Total Market Value</b>                                |            | <b>\$ 1,390,954.33</b><br><b>\$ 1,387,636.02</b> | <b>46,236.00</b><br><b>17,452.93</b> | <b>3.32%</b>  |
| <b>Total Market Value Plus Accruals</b>                  |            | <b>\$ 1,408,407.26</b>                           |                                      |               |

**Income Activity**

|   | Date     | Income Cash | Principal Cash |
|---|----------|-------------|----------------|
| <b>Interest Income</b>  |          |             |                |
| Bank of The West Advantage Acct   |          |             |                |
| Int To 03/31/20   | 04/01/20 |             | 16.91          |
| Int To 04/30/20   | 05/01/20 |             | 17.24          |
| Int To 05/31/20   | 06/01/20 |             | 4.47           |
| Clemson Univ S C Univ Revs Athletic<br>Facs Rev Bds 2.00% Dtd 02/01/2012<br>Due 05/01/2022 Non-Callable |          |             |                |
| Int To 05/01/20 on 45,000   | 05/01/20 |             | 450.00         |
| Federal Farm Cr Bks Cons Systemwide<br>Bds 1.64% Dtd 12/11/2019 Due<br>06/11/2021 Callable              |          |             |                |
| Interest At Full Call of  | 04/01/20 |             | 50.11          |



**WBSD - RATE STABILIZATION RESERVE**

Account Number:  
 Statement Period:

04/01/20 -  
 06/30/20

| Income Activity  |                      |                |                    |
|--|----------------------|----------------|--------------------|
|  | Date                 | Income Cash    | Principal Cash     |
| Federal Home Ln Mtg Corp<br>1.60% Dtd 05/15/2017 Due 05/15/2020<br>Callable<br>Int To 05/15/20 on 40,000   | 05/15/20             |                | 320.00             |
| Federal Natl Mtg Assn<br>1.875% Dtd 04/10/2017 Due 04/05/2022<br>Non-Callable<br>Int To 04/05/20 on 95,000   | 04/06/20             |                | 890.62             |
| Federal Natl Mtg Assn<br>1.80% Dtd 10/26/2012 Due 10/26/2021<br>Callable<br>Int To 04/26/20 on 20,000<br>Interest At Full Call of                                | 04/27/20<br>06/26/20 |                | 180.00<br>60.00    |
| US Treasury Note<br>1.625% Dtd 11/30/2015 Due 11/30/2020<br>Int To 05/31/20 on 150,000   | 06/01/20             |                | 1,218.75           |
| US Treasury Note<br>0.125% Dtd 04/15/2016 Due 04/15/2021<br>Treasury Inflation Protection<br>Security<br>Int To 04/15/20 on 10898.50                             | 04/15/20             |                | 6.81               |
| US Treasury Note<br>1.875% Dtd 12/15/2017 Due 12/15/2020<br>Int To 06/15/20 on 20,000  | 06/15/20             |                | 187.50             |
| <b>Total Interest Income</b>   |                      | <b>\$ 0.00</b> | <b>\$ 3,402.41</b> |
| <b>Purchased Income</b>  |                      |                |                    |
| Apple Inc Sr Gbl Nt<br>0.75% Dtd 05/11/2020 Due 05/11/2023<br>Callable<br>Accrued Int To 06/02/20 Paid on<br>Purchase of 20,000                                  | 06/02/20             |                | -8.75              |
| Citibank NA N Y<br>2.85% Dtd 02/15/2018 Due 02/12/2021<br>Callable<br>Accrued Int To 04/15/20 Paid on<br>Purchase of 60,000                                      | 04/15/20             |                | -299.25            |
| Clemson Univ S C Univ Revs Athletic<br>Facs Rev Bds 2.00% Dtd 02/01/2012<br>Due 05/01/2022 Non-Callable<br>Accrued Int To 04/15/20 Paid on<br>Purchase of 45,000 | 04/15/20             |                | -410.00            |



**WBSD - RATE STABILIZATION RESERVE**

Account Number:  
 Statement Period:

04/01/20 -  
 06/30/20

| Income Activity   |          |                |                    |
|---|----------|----------------|--------------------|
|   | Date     | Income Cash    | Principal Cash     |
| Toyota Motor Credit Corp Fr<br>2.90% Dtd 04/01/2020 Due 03/30/2023<br>Non-Callable<br>Accrued Int To 05/29/20 Paid on<br>Purchase of 10,000 | 05/29/20 |                | -46.73             |
| <b>Total Purchased Income</b>   |          | <b>\$ 0.00</b> | <b>\$ -764.73</b>  |
| <b>Total Income</b>   |          | <b>\$ 0.00</b> | <b>\$ 2,637.68</b> |

| Disbursement Activity      |          |                |                   |
|----------------------------|----------|----------------|-------------------|
|                            | Date     | Income Cash    | Principal Cash    |
| <b>Fees/Expenses</b>       |          |                |                   |
| Monthly Fee To 03/31/20    | 04/15/20 |                | -245.47           |
| Monthly Fee To 04/30/20    | 05/15/20 |                | -236.95           |
| Monthly Fee To 05/31/20    | 06/15/20 |                | -236.73           |
| <b>Total Fees/Expenses</b> |          | <b>\$ 0.00</b> | <b>\$ -719.15</b> |
| <b>Total Disbursements</b> |          | <b>\$ 0.00</b> | <b>\$ -719.15</b> |

| Purchase Activity   |          |             |                |
|---|----------|-------------|----------------|
|   | Date     | Income Cash | Principal Cash |
| Bank of The West Advantage Acct<br>Purchases (8) 04/01/20 To 06/30/20   | 06/30/20 |             | -73,395.60     |
| Apple Inc Sr Gbl Nt<br>0.75% Dtd 05/11/2020 Due 05/11/2023<br>Callable<br>Purchased 20000 05/29/20<br>From BNY Mellon/Toronto Dominion Sec<br>@ 101.187 | 06/02/20 |             | -20,237.40     |
| Citibank NA N Y<br>2.85% Dtd 02/15/2018 Due 02/12/2021<br>Callable<br>Purchased 60000 04/13/20<br>From BNY Mellon/Toronto Dominion Sec<br>@ 100.83      | 04/15/20 |             | -60,498.00     |





**WBSD - RATE STABILIZATION RESERVE**

Account Number:  
 Statement Period:

04/01/20 -  
 06/30/20

| Purchase Activity   |          |                |                       |
|---|----------|----------------|-----------------------|
|   | Date     | Income Cash    | Principal Cash        |
| Clemson Univ S C Univ Revs Athletic<br>Facs Rev Bds 2.00% Dtd 02/01/2012<br>Due 05/01/2022 Non-Callable<br>Purchased 45000 04/13/20<br>From Piper & Jaffray & Co<br>@ 101.002 | 04/15/20 |                | -45,450.90            |
| Toyota Motor Credit Corp Fr<br>2.90% Dtd 04/01/2020 Due 03/30/2023<br>Non-Callable<br>Purchased 10000 05/27/20<br>From BNY Mellon/Toronto Dominion Sec<br>@ 105.394           | 05/29/20 |                | -10,539.40            |
| <b>Total Purchases</b>  |          | <b>\$ 0.00</b> | <b>\$ -210,121.30</b> |

| Sale Activity   |          |                      |                    |
|---|----------|----------------------|--------------------|
|   | Date     | Proceeds             | Realized Gain/Loss |
| Bank of The West Advantage Acct<br>Sales (6) 04/01/20 To 06/30/20   | 06/30/20 | 138,202.77           |                    |
| Federal Farm Cr Bks Cons Systemwide<br>Bds 1.64% Dtd 12/11/2019 Due<br>06/11/2021 Callable<br>Recd Proceeds on Full Call of<br>10,000 Par Value | 04/01/20 | 10,000.00            |                    |
| Federal Home Ln Mtg Corp<br>1.60% Dtd 05/15/2017 Due 05/15/2020<br>Callable<br>Recd Proceeds on Maturity of<br>40,000 Par Value                 | 05/15/20 | 40,000.00            |                    |
| Federal Natl Mtg Assn<br>1.80% Dtd 10/26/2012 Due 10/26/2021<br>Callable<br>Recd Proceeds on Full Call of<br>20,000 Par Value                   | 06/26/20 | 20,000.00            |                    |
| <b>Total Sales</b>  |          | <b>\$ 208,202.77</b> | <b>\$ 0.00</b>     |



**WBSD - RATE STABILIZATION RESERVE**

Account Number:  
 Statement Period:

04/01/20 -  
 06/30/20

| Non-Cash Activity  |          |                  |
|--|----------|------------------|
|  | Date     | Cost             |
| Clemson Univ S C Univ Revs Athletic<br>Facs Rev Bds 2.00% Dtd 02/01/2012<br>Due 05/01/2022 Non-Callable<br>Amortization of Premium | 05/01/20 | -9.45            |
| Federal Natl Mtg Assn<br>1.875% Dtd 04/10/2017 Due 04/05/2022<br>Non-Callable<br>Amortization of Premium                           | 04/03/20 | -38.95           |
| US Treasury Note<br>1.625% Dtd 11/30/2015 Due 11/30/2020<br>Accretion of Discount  | 05/29/20 | 867.91           |
| US Treasury Note<br>0.125% Dtd 04/15/2016 Due 04/15/2021<br>Treasury Inflation Protection<br>Security                              |          |                  |
| Inflationary Int Adjustment 04/14/20   | 04/14/20 | 15.30            |
| Inflationary Int Adjustment 04/29/20   | 04/29/20 | 14.90            |
| Inflationary Int Adjustment 05/14/20   | 05/14/20 | -9.80            |
| Inflationary Int Adjustment 05/28/20   | 05/28/20 | -12.20           |
| Inflationary Int Adjustment 06/12/20   | 06/12/20 | -34.80           |
| Inflationary Int Adjustment 06/30/20   | 06/30/20 | -36.40           |
| US Treasury Note<br>1.875% Dtd 12/15/2017 Due 12/15/2020<br>Amortization of Premium  | 06/15/20 | -58.61           |
| <b>Total Non-Cash Transactions</b>   |          | <b>\$ 697.90</b> |

SECURITY PRICES CONTAINED IN THIS STATEMENT ARE OBTAINED FROM THE MOST RELIABLE SOURCES AVAILABLE BUT ARE NOT GUARANTEED BY BANK OF THE WEST. QUOTED PRICES MAY NOT EQUAL ACTUAL PRICES BECAUSE OF SECURITY SIZE, MARKET PRICE, TERM AND DEMAND.



## **Electronic Funds Transfers**

### Preauthorized Transfers:

You may request an electronic fund transfer (EFT), such as an ACH transfer from or deposit to your account, by contacting your account Administrator. You may also preauthorize periodic EFTs by contacting your account Administrator. If you would like to know whether a preauthorized EFT has occurred, please contact your account Administrator at the phone number listed on the first page of your statement, or call 1-877-898-1003 (TTY 1-800-659-5495) between the hours of 8:00 A.M. to 5:00 P.M. Pacific Standard Time.

### Error Resolution Notice:

If you think a statement or receipt is wrong or if you need more information about an EFT listed on a statement or receipt, telephone us at 1-877-898-1003 (TTY 1-800-659-5495) between the hours of 8:00 A.M. to 5:00 P.M. Pacific Standard Time, write to us at Bank of the West, 13300 Crossroads Parkway North, City of Industry, CA 91746, or e-mail us at [WMGIFSOperations@bankofthewest.com](mailto:WMGIFSOperations@bankofthewest.com) as soon as possible. We must hear from you no later than 60 days after we sent the FIRST statement on which the problem or error appeared.

1. Tell us your name and account number (if any).
2. Tell us the dollar amount of the suspected error.
3. Describe the error or the transfer you are unsure about, and explain as clearly as you can why you believe it is an error or why you need more information.

If you contact us verbally, we may require that you send us your complaint or question in writing within 10 business days. We will investigate your complaint and will correct any error promptly. If we take more than 10 business days to do this, we will credit your account for the amount you think is in error, so that you will have the use of the money during the time it takes us to complete our investigation.



**WBSD - RECYCLED WATER CASH FLOW**

Account Number:  
 Statement Period:

04/01/20 -  
 06/30/20

WEST BAY SANITARY DISTRICT  
 RECYCLED WATER CASH FLOW  
 500 LAUREL STREET  
 MENLO PARK CA 94025

**Fiduciary**  
 Chuen Ying Lee  
 (408) 645-3234  
**Portfolio**  
 Michael D. Smith  
 (408) 490-2079

**Asset Allocation**

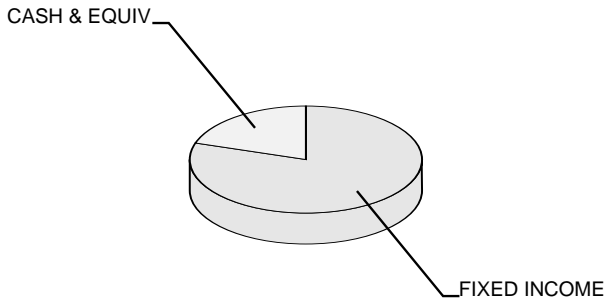

**Asset Valuation**

| Description            | Market Value         | % of Account  |
|------------------------|----------------------|---------------|
| Cash & Equiv           | 45,257.27            | 19.9%         |
| Fixed Income           | 182,023.41           | 80.1%         |
| <b>Total Portfolio</b> | <b>\$ 227,280.68</b> | <b>100.0%</b> |
| Accrued Income         | 1,182.99             |               |
| <b>Total Valuation</b> | <b>\$ 228,463.67</b> |               |

**Market Reconciliation**

|   | Current Period       | Year To Date         |
|---|----------------------|----------------------|
| <b>Beginning Market Value</b>                     | <b>\$ 226,503.27</b> | <b>\$ 223,524.55</b> |
| Income  |                      |                      |
| Interest.....                                     | 998.59               | 4,329.26             |
| Purchased Income.....                             | -63.55               | -915.81              |
| Disbursements.....                                | -116.75              | -463.02              |
| Realized Gains/(Losses).....                      | 0.00                 | 0.00                 |
| Change In Accrued Income.....                     | 166.33               | 651.98               |
| Change In Market Appreciation/(Depreciation)..... | 1,284.20             | 1,581.24             |
| Non-Cash Asset Changes.....                       | -308.42              | -244.53              |
| <b>Ending Market Value</b>                        | <b>\$ 228,463.67</b> | <b>\$ 228,463.67</b> |



**WBSD - RECYCLED WATER CASH FLOW**

Account Number:  
Statement Period:

04/01/20 -  
06/30/20

**Asset Position As of 06/30/20**

| Asset Description  | Units      | Market Value<br>Cost                         | Est. Annual Income<br>Accruals     | Current<br>Yield |
|--|------------|--|------------------------------------|------------------|
| <b>Cash Equivalents</b>  |            |  |                                    |                  |
| Bank of The West Advantage Acct  | 45,257.270 | 45,257.27<br>45,257.27                       | 54.00<br>1.21                      | 0.12%            |
| <b>Total Cash Equivalents</b>  |            | <b>\$ 45,257.27</b><br><b>\$ 45,257.27</b>   | <b>54.00</b><br><b>1.21</b>        | <b>0.12%</b>     |
| <b>Fixed Income</b>  |            |  |                                    |                  |
| New York N Y GO Bds Subser Taxable<br>4.669% Dtd 10/15/2009 Due 10/01/2022<br>Callable                               | 35,000.000 | 37,961.00<br>37,231.95                       | 1,634.00<br>408.53                 | 4.30%            |
| San Francisco Calif City & Cnt<br>Taxable Ref Bds 2019 A Taxable<br>1.814% Dtd 01/09/2020 Due 11/01/2020<br>Callable | 25,000.000 | 25,106.75<br>25,012.50                       | 453.00<br>216.67                   | 1.81%            |
| US Treasury Note<br>0.125% Dtd 04/15/2016 Due 04/15/2021<br>Treasury Inflation Protection<br>Security                | 37,870.700 | 38,050.96<br>37,778.70                       | 47.00<br>10.02                     | 0.12%            |
| US Treasury Note<br>1.875% Dtd 12/15/2017 Due 12/15/2020   | 30,000.000 | 30,233.70<br>30,157.00                       | 562.00<br>24.59                    | 1.86%            |
| US Treasury Note<br>2.50% Dtd 01/31/2019 Due 01/31/2021  | 50,000.000 | 50,671.00<br>50,416.82                       | 1,250.00<br>521.97                 | 2.47%            |
| <b>Total Fixed Income</b>  |            | <b>\$ 182,023.41</b><br><b>\$ 180,596.97</b> | <b>3,946.00</b><br><b>1,181.78</b> | <b>2.17%</b>     |
| <b>Cash</b>  |            |  |                                    |                  |
| Principal Cash   |            | 0.00<br>0.00                                 | 0.00                               | 0.00%            |
| Income Cash  |            | 0.00<br>0.00                                 | 0.00                               | 0.00%            |
| <b>Total Cash</b>  |            | <b>\$ 0.00</b><br><b>\$ 0.00</b>             | <b>0.00</b><br><b>0.00</b>         | <b>0.00%</b>     |
| <b>Total Market Value</b>  |            | <b>\$ 227,280.68</b><br><b>\$ 225,854.24</b> | <b>4,000.00</b><br><b>1,182.99</b> | <b>1.76%</b>     |
| <b>Total Market Value Plus Accruals</b>  |            | <b>\$ 228,463.67</b>                         |                                    |                  |



**WBSD - RECYCLED WATER SRF RESERVE**

Account Number:  
 Statement Period:

04/01/20 -  
 06/30/20

WEST BAY SANITARY DISTRICT  
 RECYCLED WATER SRF RESERVE  
 500 LAUREL STREET  
 MENLO PARK CA 94025

**Fiduciary**  
 Chuen Ying Lee  
 (408) 645-3234  
**Portfolio**  
 Michael D. Smith  
 (408) 490-2079

**Asset Allocation**

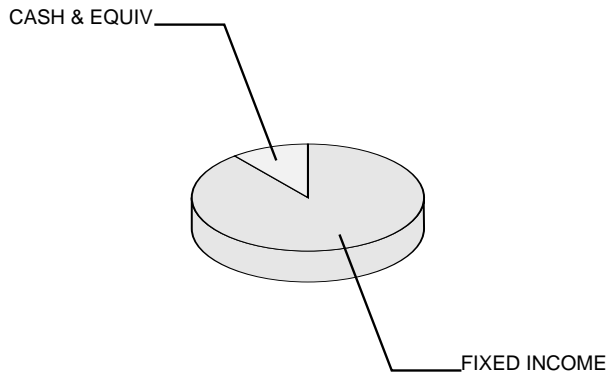

**Asset Valuation**

| Description            | Market Value           | % of Account  |
|------------------------|------------------------|---------------|
| Cash & Equiv           | 174,687.26             | 11.5%         |
| Fixed Income           | 1,346,744.87           | 88.5%         |
| <b>Total Portfolio</b> | <b>\$ 1,521,432.13</b> | <b>100.0%</b> |
| Accrued Income         | 8,917.42               |               |
| <b>Total Valuation</b> | <b>\$ 1,530,349.55</b> |               |

**Market Reconciliation**

|   | Current Period         | Year To Date           |
|---|------------------------|------------------------|
| <b>Beginning Market Value</b>                     | <b>\$ 853,842.13</b>   | <b>\$ 838,864.78</b>   |
| Income  |                        |                        |
| Interest.....                                     | 5,567.00               | 23,970.51              |
| Purchased Income.....                             | -5,788.62              | -7,759.90              |
| Additions.....                                    | 675,540.88             | 675,540.88             |
| Disbursements.....                                | -438.58                | -1,735.05              |
| Realized Gains/(Losses).....                      | 1,283.17               | 2,941.80               |
| Change In Accrued Income.....                     | 5,188.29               | 3,995.65               |
| Change In Market Appreciation/(Depreciation)..... | -4,654.47              | -4,448.47              |
| Non-Cash Asset Changes.....                       | -190.25                | -1,020.65              |
| <b>Ending Market Value</b>                        | <b>\$ 1,530,349.55</b> | <b>\$ 1,530,349.55</b> |



**WBSD - RECYCLED WATER SRF RESERVE**

Account Number:  
Statement Period:

04/01/20 -  
06/30/20

**Asset Position As of 06/30/20**

| Asset Description  | Units       | Market Value Cost                            | Est. Annual Income Accruals   | Current Yield |
|--|-------------|--|-------------------------------|---------------|
| <b>Cash Equivalents</b>  |             |  |                               |               |
| Bank of The West Advantage Acct  | 174,687.260 | 174,687.26<br>174,687.26                     | 209.00<br>45.46               | 0.12%         |
| <b>Total Cash Equivalents</b>  |             | <b>\$ 174,687.26</b><br><b>\$ 174,687.26</b> | <b>209.00</b><br><b>45.46</b> | <b>0.12%</b>  |
| <b>Fixed Income</b>  |             |  |                               |               |
| American Express Co Sr Gbl<br>2.50% Dtd 07/30/2019 Due 07/30/2024<br>Callable                    | 100,000.000 | 105,843.00<br>105,752.00                     | 2,500.00<br>1,048.60          | 2.36%         |
| Apple Inc Sr Gbl Nt<br>0.75% Dtd 05/11/2020 Due 05/11/2023<br>Callable                           | 40,000.000  | 40,421.60<br>40,474.80                       | 300.00<br>41.65               | 0.74%         |
| Autozone Inc Sr Gbl<br>2.50% Dtd 04/29/2015 Due 04/15/2021<br>Callable                           | 20,000.000  | 20,278.80<br>20,268.40                       | 500.00<br>105.55              | 2.47%         |
| Bristol Myers Squibb Co Sr Gbl 144a<br>2.60% Dtd 05/16/2019 Due 05/16/2022<br>Callable           | 70,000.000  | 72,778.30<br>72,794.40                       | 1,820.00<br>227.49            | 2.50%         |
| California Health Facs Fing Au Bds<br>2019 A 5.00% Dtd 08/06/2019 Due<br>11/01/2022 Non-Callable | 25,000.000  | 27,562.25<br>27,074.75                       | 1,250.00<br>208.33            | 4.54%         |
| Credit Suisse Ag New York Bran Fr<br>2.80% Dtd 04/09/2020 Due 04/08/2022<br>Non-Callable         | 30,000.000  | 31,124.10<br>31,093.20                       | 840.00<br>191.32              | 2.70%         |
| Disney Walt Co Sr Gbl Nt<br>1.65% Dtd 09/06/2019 Due 09/01/2022<br>Callable                      | 30,000.000  | 30,698.40<br>30,636.60                       | 495.00<br>164.99              | 1.61%         |
| Exxon Mobil Corp Sr Gbl Nt<br>1.902% Dtd 08/16/2019 Due 08/16/2022<br>Callable                   | 30,000.000  | 30,935.10<br>30,960.30                       | 570.00<br>213.97              | 1.84%         |
| Federal Farm Cr Bks Cons Systemwide<br>Bds 3.65% Dtd 12/21/2010 Due<br>12/21/2020 Non-Callable   | 96,000.000  | 97,584.96<br>96,519.36                       | 3,504.00<br>97.33             | 3.59%         |
| Huntington Bancshares Inc Sr Gbl Nt<br>2.625% Dtd 08/06/2019 Due 08/06/2024<br>Callable          | 100,000.000 | 105,886.00<br>105,942.00                     | 2,625.00<br>1,057.29          | 2.48%         |



**WBSD - RECYCLED WATER SRF RESERVE**

Account Number:  
Statement Period:

04/01/20 -  
06/30/20

**Asset Position As of 06/30/20**

| Asset Description  | Units       | Market Value<br>Cost                             | Est. Annual Income<br>Accruals      | Current<br>Yield |
|--|-------------|--|-------------------------------------|------------------|
| Intel Corp Sr Gbl<br>3.40% Dtd 03/25/2020 Due 03/25/2025<br>Callable   | 80,000.000  | 89,752.00<br>89,976.80                           | 2,720.00<br>725.33                  | 3.03%            |
| JPMorgan Chase & Co Sr Nt<br>3.25% Dtd 09/24/2012 Due 09/23/2022<br>Non-Callable                                     | 30,000.000  | 31,678.80<br>31,612.50                           | 975.00<br>265.41                    | 3.08%            |
| Morgan Stanley Fr<br>5.75% Dtd 01/25/2011 Due 01/25/2021<br>Callable   | 20,000.000  | 20,597.20<br>20,679.20                           | 1,150.00<br>498.33                  | 5.58%            |
| Qualcomm Inc Fr<br>2.60% Dtd 05/26/2017 Due 01/30/2023<br>Callable   | 90,000.000  | 94,469.40<br>94,574.70                           | 2,340.00<br>981.50                  | 2.48%            |
| San Francisco Calif City & Cnt<br>Taxable Ref Bds 2019 A Taxable<br>1.814% Dtd 01/09/2020 Due 11/01/2020<br>Callable | 25,000.000  | 25,106.75<br>25,012.50                           | 453.00<br>216.67                    | 1.81%            |
| Toyota Motor Credit Corp Fr<br>3.00% Dtd 04/01/2020 Due 04/01/2025<br>Callable                                       | 80,000.000  | 86,946.40<br>87,890.40                           | 2,400.00<br>600.00                  | 2.76%            |
| US Treasury Note<br>0.125% Dtd 04/15/2016 Due 04/15/2021<br>Treasury Inflation Protection<br>Security                | 21,640.400  | 21,743.41<br>21,587.83                           | 27.00<br>5.72                       | 0.12%            |
| US Treasury Note<br>2.00% Dtd 09/30/2013 Due 09/30/2020  | 20,000.000  | 20,091.00<br>19,958.05                           | 400.00<br>100.54                    | 1.99%            |
| US Treasury Note<br>1.375% Dtd 09/15/2017 Due 09/15/2020   | 50,000.000  | 50,124.50<br>50,121.71                           | 687.00<br>201.76                    | 1.37%            |
| US Treasury Note<br>1.875% Dtd 12/15/2017 Due 12/15/2020   | 100,000.000 | 100,779.00<br>100,523.34                         | 1,875.00<br>81.96                   | 1.86%            |
| US Treasury Note<br>2.375% Dtd 03/15/2018 Due 03/15/2021   | 50,000.000  | 50,775.50<br>50,777.27                           | 1,187.00<br>348.50                  | 2.34%            |
| US Treasury Note<br>2.75% Dtd 09/30/2018 Due 09/30/2020  | 140,000.000 | 140,897.40<br>140,269.82                         | 3,850.00<br>967.75                  | 2.73%            |
| US Treasury Note<br>2.50% Dtd 01/31/2019 Due 01/31/2021  | 50,000.000  | 50,671.00<br>50,416.82                           | 1,250.00<br>521.97                  | 2.47%            |
| <b>Total Fixed Income</b>  |             | <b>\$ 1,346,744.87</b><br><b>\$ 1,344,916.75</b> | <b>33,718.00</b><br><b>8,871.96</b> | <b>2.50%</b>     |





**WBSD - RECYCLED WATER SRF RESERVE**

Account Number:  
 Statement Period:

04/01/20 -  
 06/30/20

**Asset Position As of 06/30/20**

| Asset Description                       | Units | Market Value<br>Cost                             | Est. Annual Income<br>Accruals      | Current<br>Yield |
|---|-------|--|-------------------------------------|------------------|
| <b>Cash</b>                             |       |  |                                     |                  |
| Principal Cash                          |       | 0.00<br>0.00                                     | 0.00                                | 0.00%            |
| Income Cash                             |       | 0.00<br>0.00                                     | 0.00                                | 0.00%            |
| <b>Total Cash</b>                       |       | <b>\$ 0.00</b><br><b>\$ 0.00</b>                 | <b>0.00</b><br><b>0.00</b>          | <b>0.00%</b>     |
| <b>Total Market Value</b>               |       | <b>\$ 1,521,432.13</b><br><b>\$ 1,519,604.01</b> | <b>33,927.00</b><br><b>8,917.42</b> | <b>2.23%</b>     |
| <b>Total Market Value Plus Accruals</b> |       | <b>\$ 1,530,349.55</b>                           |                                     |                  |

**Income Activity**

|  | Date     | Income Cash | Principal Cash |
|--|----------|-------------|----------------|
| <b>Interest Income</b>   |          |             |                |
| Bank of The West Advantage Acct  |          |             |                |
| Int To 03/31/20  | 04/01/20 |             | 32.71          |
| Int To 04/30/20  | 05/01/20 |             | 7.29           |
| Int To 05/31/20  | 06/01/20 |             | 36.16          |
| California Health Facs Fing Au Bds<br>2019 A 5.00% Dtd 08/06/2019 Due<br>11/01/2022 Non-Callable |          |             |                |
| Int To 05/01/20 on 25,000  | 05/01/20 |             | 625.00         |
| Federal Farm Cr Bks Cons Systemwide<br>Bds 1.64% Dtd 12/11/2019 Due<br>06/11/2021 Callable       |          |             |                |
| Interest At Full Call of   | 04/01/20 |             | 100.22         |
| Federal Farm Cr Bks Cons Systemwide<br>Bds 3.65% Dtd 12/21/2010 Due<br>12/21/2020 Non-Callable   |          |             |                |
| Int To 06/21/20 on 96,000  | 06/22/20 |             | 1,752.00       |
| Federal Natl Mtg Assn<br>1.80% Dtd 10/26/2012 Due 10/26/2021<br>Callable                         |          |             |                |
| Int To 04/26/20 on 40,000  | 04/27/20 |             | 360.00         |
| Interest At Full Call of   | 06/26/20 |             | 120.00         |



**WBSD - RECYCLED WATER SRF RESERVE**

Account Number:  
 Statement Period:

04/01/20 -  
 06/30/20

| Income Activity   |          |                |                    |
|---|----------|----------------|--------------------|
|   | Date     | Income Cash    | Principal Cash     |
| Federal Natl Mtg Assn<br>1.55% Dtd 10/28/2016 Due 10/28/2021<br>Callable<br>Int To 04/28/20 on 80,000   | 04/28/20 |                | 620.00             |
| US Treasury Note<br>1.375% Dtd 04/30/2015 Due 04/30/2020<br>Int To 04/30/20 on 140,000  | 04/30/20 |                | 962.50             |
| US Treasury Note<br>0.125% Dtd 04/15/2016 Due 04/15/2021<br>Treasury Inflation Protection<br>Security<br>Int To 04/15/20 on 21797                         | 04/15/20 |                | 13.62              |
| US Treasury Note<br>1.875% Dtd 12/15/2017 Due 12/15/2020<br>Int To 06/15/20 on 100,000  | 06/15/20 |                | 937.50             |
| <b>Total Interest Income</b>  |          | <b>\$ 0.00</b> | <b>\$ 5,567.00</b> |
| <b>Purchased Income</b>   |          |                |                    |
| American Express Co Sr Gbl<br>2.50% Dtd 07/30/2019 Due 07/30/2024<br>Callable<br>Accrued Int To 06/19/20 Paid on<br>Purchase of 100,000                   | 06/19/20 |                | -965.27            |
| Apple Inc Sr Gbl Nt<br>0.75% Dtd 05/11/2020 Due 05/11/2023<br>Callable<br>Accrued Int To 06/02/20 Paid on<br>Purchase of 40,000                           | 06/02/20 |                | -17.49             |
| Autozone Inc Sr Gbl<br>2.50% Dtd 04/29/2015 Due 04/15/2021<br>Callable<br>Accrued Int To 05/29/20 Paid on<br>Purchase of 20,000                           | 05/29/20 |                | -61.11             |
| Bristol Myers Squibb Co Sr Gbl 144a<br>2.60% Dtd 05/16/2019 Due 05/16/2022<br>Callable<br>Accrued Int To 06/19/20 Paid on<br>Purchase of 70,000           | 06/19/20 |                | -166.83            |
| California Health Facs Fing Au Bds<br>2019 A 5.00% Dtd 08/06/2019 Due<br>11/01/2022 Non-Callable<br>Accrued Int To 04/15/20 Paid on<br>Purchase of 25,000 | 04/15/20 |                | -569.44            |



**WBSD - RECYCLED WATER SRF RESERVE**

Account Number:  
 Statement Period:

04/01/20 -  
 06/30/20

| Income Activity   |          |             |                |
|---|----------|-------------|----------------|
|   | Date     | Income Cash | Principal Cash |
| Credit Suisse Ag New York Bran Fr<br>2.80% Dtd 04/09/2020 Due 04/08/2022<br>Non-Callable<br>Accrued Int To 05/29/20 Paid on<br>Purchase of 30,000 | 05/29/20 |             | -116.66        |
| Disney Walt Co Sr Gbl Nt<br>1.65% Dtd 09/06/2019 Due 09/01/2022<br>Callable<br>Accrued Int To 05/29/20 Paid on<br>Purchase of 30,000              | 05/29/20 |             | -120.99        |
| Exxon Mobil Corp Sr Gbl Nt<br>1.902% Dtd 08/16/2019 Due 08/16/2022<br>Callable<br>Accrued Int To 06/02/20 Paid on<br>Purchase of 30,000           | 06/02/20 |             | -168.01        |
| Huntington Bancshares Inc Sr Gbl Nt<br>2.625% Dtd 08/06/2019 Due 08/06/2024<br>Callable<br>Accrued Int To 06/19/20 Paid on<br>Purchase of 100,000 | 06/19/20 |             | -969.79        |
| Intel Corp Sr Gbl<br>3.40% Dtd 03/25/2020 Due 03/25/2025<br>Callable<br>Accrued Int To 06/19/20 Paid on<br>Purchase of 80,000                     | 06/19/20 |             | -634.67        |
| JPMorgan Chase & Co Sr Nt<br>3.25% Dtd 09/24/2012 Due 09/23/2022<br>Non-Callable<br>Accrued Int To 05/29/20 Paid on<br>Purchase of 30,000         | 05/29/20 |             | -178.75        |
| Morgan Stanley Fr<br>5.75% Dtd 01/25/2011 Due 01/25/2021<br>Callable<br>Accrued Int To 05/29/20 Paid on<br>Purchase of 20,000                     | 05/29/20 |             | -396.11        |
| Qualcomm Inc Fr<br>2.60% Dtd 05/26/2017 Due 01/30/2023<br>Callable<br>Accrued Int To 06/19/20 Paid on<br>Purchase of 90,000                       | 06/19/20 |             | -903.50        |



**WBSD - RECYCLED WATER SRF RESERVE**

Account Number:  
 Statement Period:

04/01/20 -  
 06/30/20

| Income Activity   |          |                |                     |
|---|----------|----------------|---------------------|
|   | Date     | Income Cash    | Principal Cash      |
| Toyota Motor Credit Corp Fr<br>3.00% Dtd 04/01/2020 Due 04/01/2025<br>Callable<br>Accrued Int To 06/19/20 Paid on<br>Purchase of 80,000 | 06/19/20 |                | -520.00             |
| <b>Total Purchased Income</b>   |          | <b>\$ 0.00</b> | <b>\$ -5,788.62</b> |
| <b>Total Income</b>   |          | <b>\$ 0.00</b> | <b>\$ -221.62</b>   |

| Additions   |          |                |                      |
|---|----------|----------------|----------------------|
|   | Date     | Income Cash    | Principal Cash       |
| <b>Miscellaneous Additions</b>  |          |                |                      |
| Addition To Account<br>Transfer From Bank of The West<br>Ckg Ending In 6049 Per Client<br>Instruction: 6/3/20 | 06/04/20 |                | 675,540.88           |
| <b>Total Miscellaneous Additions</b>  |          | <b>\$ 0.00</b> | <b>\$ 675,540.88</b> |
| <b>Total Additions</b>  |          | <b>\$ 0.00</b> | <b>\$ 675,540.88</b> |

| Disbursement Activity      |          |                |                   |
|----------------------------|----------|----------------|-------------------|
|                            | Date     | Income Cash    | Principal Cash    |
| <b>Fees/Expenses</b>       |          |                |                   |
| Monthly Fee To 03/31/20    | 04/15/20 |                | -149.62           |
| Monthly Fee To 04/30/20    | 05/15/20 |                | -144.60           |
| Monthly Fee To 05/31/20    | 06/15/20 |                | -144.36           |
| <b>Total Fees/Expenses</b> |          | <b>\$ 0.00</b> | <b>\$ -438.58</b> |
| <b>Total Disbursements</b> |          | <b>\$ 0.00</b> | <b>\$ -438.58</b> |



**WBSD - RECYCLED WATER SRF RESERVE**

Account Number:  
 Statement Period:

04/01/20 -  
 06/30/20

| Purchase Activity   |          |                |
|---|----------|----------------|
|   | Date     | Principal Cash |
| Bank of The West Advantage Acct<br>Purchases (10) 04/01/20 To 06/30/20  | 06/30/20 | -961,094.26    |
| American Express Co Sr Gbl<br>2.50% Dtd 07/30/2019 Due 07/30/2024<br>Callable<br>Purchased 100000 06/17/20<br>From BNY Mellon/Toronto Dominion Sec<br>@ 105.752           | 06/19/20 | -105,752.00    |
| Apple Inc Sr Gbl Nt<br>0.75% Dtd 05/11/2020 Due 05/11/2023<br>Callable<br>Purchased 40000 05/29/20<br>From BNY Mellon/Toronto Dominion Sec<br>@ 101.187                   | 06/02/20 | -40,474.80     |
| Autozone Inc Sr Gbl<br>2.50% Dtd 04/29/2015 Due 04/15/2021<br>Callable<br>Purchased 20000 05/27/20<br>From BNY Mellon/Toronto Dominion Sec<br>@ 101.342                   | 05/29/20 | -20,268.40     |
| Bristol Myers Squibb Co Sr Gbl 144a<br>2.60% Dtd 05/16/2019 Due 05/16/2022<br>Callable<br>Purchased 70000 06/17/20<br>From BNY Mellon/Toronto Dominion Sec<br>@ 103.992   | 06/19/20 | -72,794.40     |
| California Health Facs Fing Au Bds<br>2019 A 5.00% Dtd 08/06/2019 Due<br>11/01/2022 Non-Callable<br>Purchased 25000 04/13/20<br>From Southwest Securities<br>@ 108.443    | 04/15/20 | -27,110.75     |
| Credit Suisse Ag New York Bran Fr<br>2.80% Dtd 04/09/2020 Due 04/08/2022<br>Non-Callable<br>Purchased 30000 05/27/20<br>From BNY Mellon/Toronto Dominion Sec<br>@ 103.644 | 05/29/20 | -31,093.20     |
| Disney Walt Co Sr Gbl Nt<br>1.65% Dtd 09/06/2019 Due 09/01/2022<br>Callable<br>Purchased 30000 05/27/20<br>From BNY Mellon/Toronto Dominion Sec<br>@ 102.122              | 05/29/20 | -30,636.60     |



**WBSD - RECYCLED WATER SRF RESERVE**

Account Number:  
 Statement Period:

04/01/20 -  
 06/30/20

| Purchase Activity   |          |                         |
|---|----------|-------------------------|
|   | Date     | Principal Cash          |
| Exxon Mobil Corp Sr Gbl Nt<br>1.902% Dtd 08/16/2019 Due 08/16/2022<br>Callable<br>Purchased 30000 05/29/20<br>From BNY Mellon/Toronto Dominion Sec<br>@ 103.201           | 06/02/20 | -30,960.30              |
| Huntington Bancshares Inc Sr Gbl Nt<br>2.625% Dtd 08/06/2019 Due 08/06/2024<br>Callable<br>Purchased 100000 06/17/20<br>From BNY Mellon/Toronto Dominion Sec<br>@ 105.942 | 06/19/20 | -105,942.00             |
| Intel Corp Sr Gbl<br>3.40% Dtd 03/25/2020 Due 03/25/2025<br>Callable<br>Purchased 80000 06/17/20<br>From BNY Mellon/Toronto Dominion Sec<br>@ 112.471                     | 06/19/20 | -89,976.80              |
| JPMorgan Chase & Co Sr Nt<br>3.25% Dtd 09/24/2012 Due 09/23/2022<br>Non-Callable<br>Purchased 30000 05/27/20<br>From BNY Mellon/Toronto Dominion Sec<br>@ 105.375         | 05/29/20 | -31,612.50              |
| Morgan Stanley Fr<br>5.75% Dtd 01/25/2011 Due 01/25/2021<br>Callable<br>Purchased 20000 05/27/20<br>From BNY Mellon/Toronto Dominion Sec<br>@ 103.396                     | 05/29/20 | -20,679.20              |
| Qualcomm Inc Fr<br>2.60% Dtd 05/26/2017 Due 01/30/2023<br>Callable<br>Purchased 90000 06/17/20<br>From BNY Mellon/Toronto Dominion Sec<br>@ 105.083                       | 06/19/20 | -94,574.70              |
| Toyota Motor Credit Corp Fr<br>3.00% Dtd 04/01/2020 Due 04/01/2025<br>Callable<br>Purchased 80000 06/17/20<br>From BNY Mellon/Toronto Dominion Sec<br>@ 109.863           | 06/19/20 | -87,890.40              |
| <b>Total Purchases</b>  |          | <b>\$ -1,750,860.31</b> |

\$ 0.00

\$ -1,750,860.31



**WBSD - RECYCLED WATER SRF RESERVE**

Account Number:  
 Statement Period:

04/01/20 -  
 06/30/20

| Sale Activity   |          |                        |                    |
|---|----------|------------------------|--------------------|
|   | Date     | Proceeds               | Realized Gain/Loss |
| Bank of The West Advantage Acct<br>Sales (7) 04/01/20 To 06/30/20   | 06/30/20 | 795,979.63             |                    |
| Federal Farm Cr Bks Cons Systemwide<br>Bds 1.64% Dtd 12/11/2019 Due<br>06/11/2021 Callable<br>Recd Proceeds on Full Call of<br>20,000 Par Value | 04/01/20 | 20,000.00              |                    |
| Federal Natl Mtg Assn<br>1.80% Dtd 10/26/2012 Due 10/26/2021<br>Callable<br>Recd Proceeds on Full Call of<br>40,000 Par Value                   | 06/26/20 | 40,000.00              |                    |
| Federal Natl Mtg Assn<br>1.55% Dtd 10/28/2016 Due 10/28/2021<br>Callable<br>Recd Proceeds on Full Call of<br>80,000 Par Value                   | 04/28/20 | 80,000.00              | 1,283.17           |
| US Treasury Note<br>1.375% Dtd 04/30/2015 Due 04/30/2020<br>Recd Proceeds on Maturity of<br>140,000 Par Value                                   | 04/30/20 | 140,000.00             |                    |
| <b>Total Sales</b>  |          | <b>\$ 1,075,979.63</b> | <b>\$ 1,283.17</b> |

| Non-Cash Activity   |          |         |
|---|----------|---------|
|   | Date     | Cost    |
| California Health Facs Fing Au Bds<br>2019 A 5.00% Dtd 08/06/2019 Due<br>11/01/2022 Non-Callable<br>Amortization of Premium | 05/01/20 | -36.00  |
| Federal Farm Cr Bks Cons Systemwide<br>Bds 3.65% Dtd 12/21/2010 Due<br>12/21/2020 Non-Callable<br>Amortization of Premium   | 06/19/20 | -512.64 |
| Federal Natl Mtg Assn<br>1.55% Dtd 10/28/2016 Due 10/28/2021<br>Callable<br>Accretion of Discount                           | 04/28/20 | 66.52   |
| US Treasury Note<br>1.375% Dtd 04/30/2015 Due 04/30/2020<br>Accretion of Discount   | 04/30/20 | 710.94  |



**WBSD - RECYCLED WATER SRF RESERVE**

Account Number:  
 Statement Period:

04/01/20 -  
 06/30/20

**Non-Cash Activity**

|   | Date     | Cost              |
|---|----------|-------------------|
| US Treasury Note<br>0.125% Dtd 04/15/2016 Due 04/15/2021<br>Treasury Inflation Protection<br>Security |          |                   |
| Inflationary Int Adjustment 04/14/20  | 04/14/20 | 30.60             |
| Inflationary Int Adjustment 04/29/20  | 04/29/20 | 29.80             |
| Inflationary Int Adjustment 05/14/20  | 05/14/20 | -19.60            |
| Inflationary Int Adjustment 05/28/20  | 05/28/20 | -24.40            |
| Inflationary Int Adjustment 06/12/20  | 06/12/20 | -69.60            |
| Inflationary Int Adjustment 06/30/20  | 06/30/20 | -72.80            |
| US Treasury Note<br>1.875% Dtd 12/15/2017 Due 12/15/2020<br>Amortization of Premium                   | 06/15/20 | -293.07           |
| <b>Total Non-Cash Transactions</b>  |          | <b>\$ -190.25</b> |

SECURITY PRICES CONTAINED IN THIS STATEMENT ARE OBTAINED FROM THE MOST RELIABLE SOURCES AVAILABLE BUT ARE NOT GUARANTEED BY BANK OF THE WEST. QUOTED PRICES MAY NOT EQUAL ACTUAL PRICES BECAUSE OF SECURITY SIZE, MARKET PRICE, TERM AND DEMAND.





## **Electronic Funds Transfers**

### Preauthorized Transfers:

You may request an electronic fund transfer (EFT), such as an ACH transfer from or deposit to your account, by contacting your account Administrator. You may also preauthorize periodic EFTs by contacting your account Administrator. If you would like to know whether a preauthorized EFT has occurred, please contact your account Administrator at the phone number listed on the first page of your statement, or call 1-877-898-1003 (TTY 1-800-659-5495) between the hours of 8:00 A.M. to 5:00 P.M. Pacific Standard Time.

### Error Resolution Notice:

If you think a statement or receipt is wrong or if you need more information about an EFT listed on a statement or receipt, telephone us at 1-877-898-1003 (TTY 1-800-659-5495) between the hours of 8:00 A.M. to 5:00 P.M. Pacific Standard Time, write to us at Bank of the West, 13300 Crossroads Parkway North, City of Industry, CA 91746, or e-mail us at [WMGIFSOperations@bankofthewest.com](mailto:WMGIFSOperations@bankofthewest.com) as soon as possible. We must hear from you no later than 60 days after we sent the FIRST statement on which the problem or error appeared.

1. Tell us your name and account number (if any).
2. Tell us the dollar amount of the suspected error.
3. Describe the error or the transfer you are unsure about, and explain as clearly as you can why you believe it is an error or why you need more information.

If you contact us verbally, we may require that you send us your complaint or question in writing within 10 business days. We will investigate your complaint and will correct any error promptly. If we take more than 10 business days to do this, we will credit your account for the amount you think is in error, so that you will have the use of the money during the time it takes us to complete our investigation.



**WBSD - RECYCLED WATER CASH FLOW**

Account Number:  
 Statement Period:

04/01/20 -  
 06/30/20

| Income Activity   |                      |                |                  |
|---|----------------------|----------------|------------------|
|   | Date                 | Income Cash    | Principal Cash   |
| <b>Interest Income</b>  |                      |                |                  |
| Bank of The West Advantage Acct   |                      |                |                  |
| Int To 03/31/20   | 04/01/20             |                | 5.57             |
| Int To 04/30/20   | 05/01/20             |                | 6.66             |
| Int To 05/31/20   | 06/01/20             |                | 0.83             |
| Federal Farm Cr Bks Cons Systemwide<br>Bds 1.64% Dtd 12/11/2019 Due<br>06/11/2021 Callable<br>Interest At Full Call of                          | 04/01/20             |                | 200.44           |
| Federal Natl Mtg Assn<br>1.80% Dtd 10/26/2012 Due 10/26/2021<br>Callable<br>Int To 04/26/20 on 40,000<br>Interest At Full Call of               | 04/27/20<br>06/26/20 |                | 360.00<br>120.00 |
| US Treasury Note<br>0.125% Dtd 04/15/2016 Due 04/15/2021<br>Treasury Inflation Protection<br>Security<br>Int To 04/15/20 on 38144.75            | 04/15/20             |                | 23.84            |
| US Treasury Note<br>1.875% Dtd 12/15/2017 Due 12/15/2020<br>Int To 06/15/20 on 30,000   | 06/15/20             |                | 281.25           |
| <b>Total Interest Income</b>  |                      | <b>\$ 0.00</b> | <b>\$ 998.59</b> |
| <b>Purchased Income</b>   |                      |                |                  |
| New York N Y GO Bds Subser Taxable<br>4.669% Dtd 10/15/2009 Due 10/01/2022<br>Callable<br>Accrued Int To 04/15/20 Paid on<br>Purchase of 35,000 | 04/15/20             |                | -63.55           |
| <b>Total Purchased Income</b>   |                      | <b>\$ 0.00</b> | <b>\$ -63.55</b> |
| <b>Total Income</b>   |                      | <b>\$ 0.00</b> | <b>\$ 935.04</b> |

| Disbursement Activity   |          |             |                |
|-------------------------|----------|-------------|----------------|
|                         | Date     | Income Cash | Principal Cash |
| <b>Fees/Expenses</b>    |          |             |                |
| Monthly Fee To 03/31/20 | 04/15/20 |             | -39.69         |
| Monthly Fee To 04/30/20 | 05/15/20 |             | -38.52         |



**WBSD - RECYCLED WATER CASH FLOW**

Account Number:  
 Statement Period:

04/01/20 -  
 06/30/20

| Disbursement Activity      |          |                |                   |
|----------------------------|----------|----------------|-------------------|
|                            | Date     | Income Cash    | Principal Cash    |
| Monthly Fee To 05/31/20    | 06/15/20 |                | -38.54            |
| <b>Total Fees/Expenses</b> |          | <b>\$ 0.00</b> | <b>\$ -116.75</b> |
| <b>Total Disbursements</b> |          | <b>\$ 0.00</b> | <b>\$ -116.75</b> |

| Purchase Activity  |          |                |                       |
|--|----------|----------------|-----------------------|
|  | Date     | Income Cash    | Principal Cash        |
| Bank of The West Advantage Acct<br>Purchases (6) 04/01/20 To 06/30/20  | 06/30/20 |                | -80,974.75            |
| New York N Y GO Bds Subser Taxable<br>4.669% Dtd 10/15/2009 Due 10/01/2022<br>Callable<br>Purchased 35000 04/13/20<br>From Headlands Holdings LLC<br>@ 106.377 | 04/15/20 |                | -37,231.95            |
| <b>Total Purchases</b>   |          | <b>\$ 0.00</b> | <b>\$ -118,206.70</b> |

| Sale Activity   |          |                      |                    |
|---|----------|----------------------|--------------------|
|   | Date     | Proceeds             | Realized Gain/Loss |
| Bank of The West Advantage Acct<br>Sales (4) 04/01/20 To 06/30/20   | 06/30/20 | 37,388.41            |                    |
| Federal Farm Cr Bks Cons Systemwide<br>Bds 1.64% Dtd 12/11/2019 Due<br>06/11/2021 Callable<br>Recd Proceeds on Full Call of<br>40,000 Par Value | 04/01/20 | 40,000.00            |                    |
| Federal Natl Mtg Assn<br>1.80% Dtd 10/26/2012 Due 10/26/2021<br>Callable<br>Recd Proceeds on Full Call of<br>40,000 Par Value                   | 06/26/20 | 40,000.00            |                    |
| <b>Total Sales</b>  |          | <b>\$ 117,388.41</b> | <b>\$ 0.00</b>     |



**WBSD - RECYCLED WATER CASH FLOW**

Account Number:  
 Statement Period:

04/01/20 -  
 06/30/20

**Non-Cash Activity**

|   | Date     | Cost              |
|---|----------|-------------------|
| US Treasury Note<br>0.125% Dtd 04/15/2016 Due 04/15/2021<br>Treasury Inflation Protection<br>Security |          |                   |
| Inflationary Int Adjustment 04/14/20  | 04/14/20 | 53.55             |
| Inflationary Int Adjustment 04/29/20  | 04/29/20 | 52.15             |
| Inflationary Int Adjustment 05/14/20  | 05/14/20 | -34.30            |
| Inflationary Int Adjustment 05/28/20  | 05/28/20 | -42.70            |
| Inflationary Int Adjustment 06/12/20  | 06/12/20 | -121.80           |
| Inflationary Int Adjustment 06/30/20  | 06/30/20 | -127.40           |
| US Treasury Note<br>1.875% Dtd 12/15/2017 Due 12/15/2020<br>Amortization of Premium                   |          |                   |
|   | 06/15/20 | -87.92            |
| <b>Total Non-Cash Transactions</b>  |          | <b>\$ -308.42</b> |

SECURITY PRICES CONTAINED IN THIS STATEMENT ARE OBTAINED FROM THE MOST RELIABLE SOURCES AVAILABLE BUT ARE NOT GUARANTEED BY BANK OF THE WEST. QUOTED PRICES MAY NOT EQUAL ACTUAL PRICES BECAUSE OF SECURITY SIZE, MARKET PRICE, TERM AND DEMAND.



## **Electronic Funds Transfers**

### **Preauthorized Transfers:**

You may request an electronic fund transfer (EFT), such as an ACH transfer from or deposit to your account, by contacting your account Administrator. You may also preauthorize periodic EFTs by contacting your account Administrator. If you would like to know whether a preauthorized EFT has occurred, please contact your account Administrator at the phone number listed on the first page of your statement, or call 1-877-898-1003 (TTY 1-800-659-5495) between the hours of 8:00 A.M. to 5:00 P.M. Pacific Standard Time.

### **Error Resolution Notice:**

If you think a statement or receipt is wrong or if you need more information about an EFT listed on a statement or receipt, telephone us at 1-877-898-1003 (TTY 1-800-659-5495) between the hours of 8:00 A.M. to 5:00 P.M. Pacific Standard Time, write to us at Bank of the West, 13300 Crossroads Parkway North, City of Industry, CA 91746, or e-mail us at [WMGIFSOperations@bankofthewest.com](mailto:WMGIFSOperations@bankofthewest.com) as soon as possible. We must hear from you no later than 60 days after we sent the FIRST statement on which the problem or error appeared.

1. Tell us your name and account number (if any).
2. Tell us the dollar amount of the suspected error.
3. Describe the error or the transfer you are unsure about, and explain as clearly as you can why you believe it is an error or why you need more information.

If you contact us verbally, we may require that you send us your complaint or question in writing within 10 business days. We will investigate your complaint and will correct any error promptly. If we take more than 10 business days to do this, we will credit your account for the amount you think is in error, so that you will have the use of the money during the time it takes us to complete our investigation.



## WEST BAY SANITARY DISTRICT AGENDA ITEM 5F

**To:** *Board of Directors*

**From:** *Bill Kitajima, Projects & IT Manager*  
*Jonathan Werness, Engineering Technician*

**Subject:** *Consideration to Authorize the District Manager to Issue the Class 3 Permit for the Sewer Main Installation on San Antonio Street, Menlo Park, CA*

---

### **Background**

1540 El Camino Real was the home of Beltramo's Wine & Spirits for 81 years. This property was sold and demolished, and is now being redeveloped with a two-story, 40,948-square foot office building, and a three-story, 34,595-square-foot residential building with 27 units and underground parking. These two new buildings will sewer to the District's main on San Antonio Street north of the property. The District currently has two sewer mains on this street, one 6-inch that flows towards Encinal Avenue, and one 6-inch that flows towards Glenwood Avenue.

Included in the developer's off-site improvement plans, is installation of a new sewer main connecting the two existing lines. This line provides redundancy in the system as an added protection from potential sewer overflows.

### **Analysis**

The plans have been reviewed and approved by District staff, and all permit and connection fees have been paid.

### **Recommendation**

The Projects & IT Manager recommends the District Board authorize the District Manager to issue Class 3 Sewer Permit No.1104 for the sewer main installation.

Attachments: Resolution \_\_\_\_ (2020)  
Notice of Exemption  
Class 3 Permit (1104)  
Exhibit A - Site Map

RESOLUTION NO. \_\_\_\_\_ (2020)

IN THE DISTRICT BOARD OF THE WEST BAY SANITARY DISTRICT  
COUNTY OF SAN MATEO, STATE OF CALIFORNIA

\*\*\*\*\*

BE IT RESOLVED, by the District Board of West Bay Sanitary District, County of San Mateo, State of California, as follows:

ENVIRONMENTAL IMPACT REVIEW

Name of Project: New San Antonio Street Sewer Main

Location: San Antonio Street, Menlo Park, CA

Entity or Person Undertaking Project: 1540 El Camino Real Development

Determination of the District Board:

The District Board hereby certifies that it has reviewed the Preliminary Review and Notice of Exemption prepared for this project and has considered the contents thereof. The Board finds that this document is adequate for use by the District in its review of the project.

The District Board finds that the following feasible alternatives and/or mitigation measures within its powers, would substantially lessen any significant effects which the project would have on the environment:

N/A

The Board certifies that the Preliminary Review and Notice of Exemption has been prepared and completed in compliance with the California Environmental Quality Act and the State Guidelines.

The Board finds that the project Preliminary Review and Notice of Exemption identifies the following significant effects:

N/A

The Board further finds that for each of these significant effects:

N/A Changes or alterations have been required in, or incorporated, into the project which mitigate or avoid the significant environmental effects thereof as identified in the Final EIR.

N/A Such changes or alterations are within the responsibility and jurisdiction of a public agency other than the District. Such changes have been adopted by such other agency or can and should be adopted by such other agency.

N/A Specific economic, social, or other considerations make infeasible the mitigation measures or project alternatives identified in the Final EIR.

Based upon the foregoing, and upon compliance with District regulations and requirements, as applicable, the project is hereby:

\_\_\_\_\_ Approved

\_\_\_\_\_ Disapproved

The District Manager of West Bay Sanitary District is directed to prepare a Notice of Exemption pursuant to the provisions of the State Guidelines Implementing the California Environmental Quality Act adopted by Resolution No. 1105 of this District Board. The District Manager is ~~(further)~~ (not) directed to prepare and file a Statement of Overriding Consideration pertaining to the approval of this project pursuant to the provisions of the same Guidelines.

\*\*\*\*\*

Passed and adopted by the District Board of West Bay Sanitary District at a regular meeting thereof held on the 12<sup>th</sup> day of August 2020, by the following vote:

Ayes:

Noes:

Abstain:

Absent:

\_\_\_\_\_  
President of the District Board of the  
West Bay Sanitary District of San Mateo  
County, State of California

Attest:

\_\_\_\_\_  
Secretary of the District Board of the  
West Bay Sanitary District of San Mateo  
County, State of California





## “PRELIMINARY REVIEW”

New San Antonio Street Sewer Main  
July 29, 2020

INTRODUCTION. At the August 12, 2020 District Board Meeting, the Board will consider the approval of the Class 3 Sewer Permit for the construction of a gravity sewer main line for the 1540 El Camino Real project in Menlo Park; and the authorization for the filing of a California Environmental Quality Act (CEQA) “Notice of Exemption” for the project. This project is proposed by the property owner, 1540 El Camino Real Development.

EXEMPTION REVIEW. In compliance with CEQA Guidelines, this “preliminary review” of the gravity sewer mainline construction on San Antonio Street was conducted to determine whether the project is exempt from CEQA. Based on this review, staff has concluded that the project is exempt from CEQA under several sections of the guidelines. In summary, the project would not have any significant impacts on the environment because it includes little or no expansion of capacity, and will employ mitigation measures to alleviate any impacts.

This preliminary review presents and elaborates upon the rationale for the conclusions reached by staff.

Staff has concluded that all project elements are exempt under CEQA Guidelines section 15061(b)(3) (known as the “General Rule”), since it can be “seen with certainty that there is no possibility that the activity in question may have a significant effect on the environment.”

This certainty is based on the District’s past experience with numerous sewer construction projects of this nature, and the mitigation measures included in all such projects to alleviate any impacts.

Past Experience. The District has completed many miles of sewer construction projects and pump station rehabilitation projects in commercial and residential areas throughout Menlo Park, Atherton, and the County of San Mateo, including the Portola Valley area. While construction-related impacts on land use, traffic, noise, air quality, erosion, drainage, public safety, and cultural resources can occur, no significant environmental impacts have resulted from this work.

The reasons these have been “less-than-significant” include the short-term nature of construction activities, application of the District’s standard construction mitigation measures, good community relations outreach programs to inform project area residents of construction activities, and active coordination with local jurisdictions.

Construction Mitigation Measures. Specific impact mitigation measures will be included in the proposed project to avoid, minimize, reduce, or rectify for construction-related impacts. These measures are used on all sewer construction projects. The measures address dust control; erosion control; noise control; protection of soils; provision for adequate drainage; protection and restoration of structures; precautions for working

near sensitive and unique vegetation, protection and restoration of vegetation, landscaping, and improvements; public health and safety precautions; community notifications; traffic control; and preservation of cultural resources.

Most project elements also are exempt as:

Staff has concluded that most project elements are “categorically exempt” under CEQA Guidelines Section 15303 (d) Water main, sewage, electrical, gas and other utility extensions of reasonable length to serve such construction.

CONCLUSION. Based on the information presented herein, staff has concluded that all of the installation of the gravity sewer main line is exempt from CEQA under the CEQA Guidelines Section 15061(b)(3) (the General Rule), and also exempt under CEQA Guideline Section 15303 (d).

# WEST BAY SANITARY DISTRICT

500 Laurel Street  
Menlo Park, California 94025  
(650) 321-0384

Permit Number  
1104

Type \_\_\_\_\_

## APPLICATION FOR CLASS 3 SEWER PERMIT

To the WEST BAY SANITARY DISTRICT:

The undersigned, being the  Owner  Owner's Agent of the property located at

1540 G/L Camino Real, Menlo Park, CA. 94025

does hereby request permission to construct sanitary sewers and related facilities to serve a

Residential  Non-residential Development at said location.

### ENGINEER'S

Sandis

Name

636 9th Street, Oakland, Ca 94607

Address

### OWNER'S

1540 G/L Development

Name

339 So. San Antonio Rd.

Address

### CONTRACTOR'S

South Bay Construction

Name

1711 Dell Ave. Campbell, Ca 95008

Address

Jeanine Andrade

Applicant's Signature

Jeanine Andrade, Project Engineer

Signed by - Please Print Name

1711 Dell Ave. Campbell, Ca 95008

Address

Receipt of \$ 585 Application Fee is hereby acknowledged [Signature] 7/28/2020

Date

Receipt of \$ 2000  Cash Deposit or  Performance Bond

Comments Sewer main installation

Approved by the District Board on \_\_\_\_\_.

Application approved and permit issued:

**WEST BAY SANITARY DISTRICT**

**Sergio Ramirez, District Manager**

Date \_\_\_\_\_

By \_\_\_\_\_

Final Acceptance by the District Board on \_\_\_\_\_.

# EXHIBIT A SITE MAP

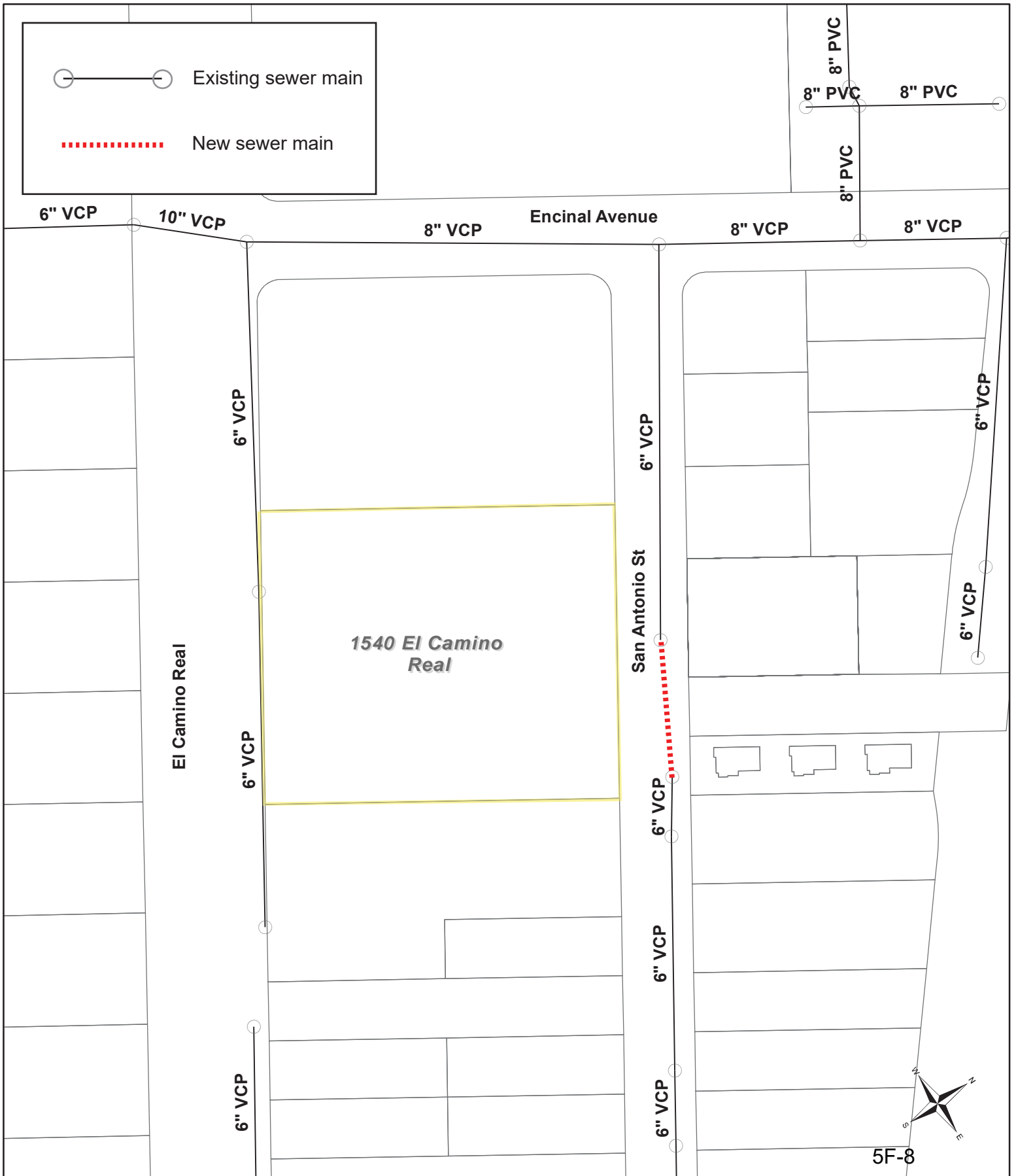



**WEST BAY SANITARY DISTRICT  
AGENDA ITEM 5G**

**To: Board of Directors**

**From: Bill Kitajima, Projects & IT Manager  
Jonathan Werness, Engineering Technician**

**Subject: Consideration to Approve Amendment to the District's  
Excavation, Backfill, and Surface Restoration Detail No. 8**

---

Background

In recent projects within unincorporated San Mateo County right-of-way, County inspectors have required contractors include a “non-woven filter fabric” between the District’s required ¾” drain rock around the pipe and the subsequent backfill. Their reasoning is to prevent the structural backfill from slowly seeping through the drain rock below.

Analysis

The District takes no issue with this requirement. Freyer & Laureta, Inc. has amended the District’s current trenching detail no. 8 to include this requirement within San Mateo County right-of-way.

Fiscal Impact

None at this time.

Recommendation

The Projects & IT Manager recommends the District Board authorize the District Manager to approve the amendment to District Detail No. 8.

Attachments: Revised WBSD Detail No. 8 – Excavation, Backfill and Surface Restoration

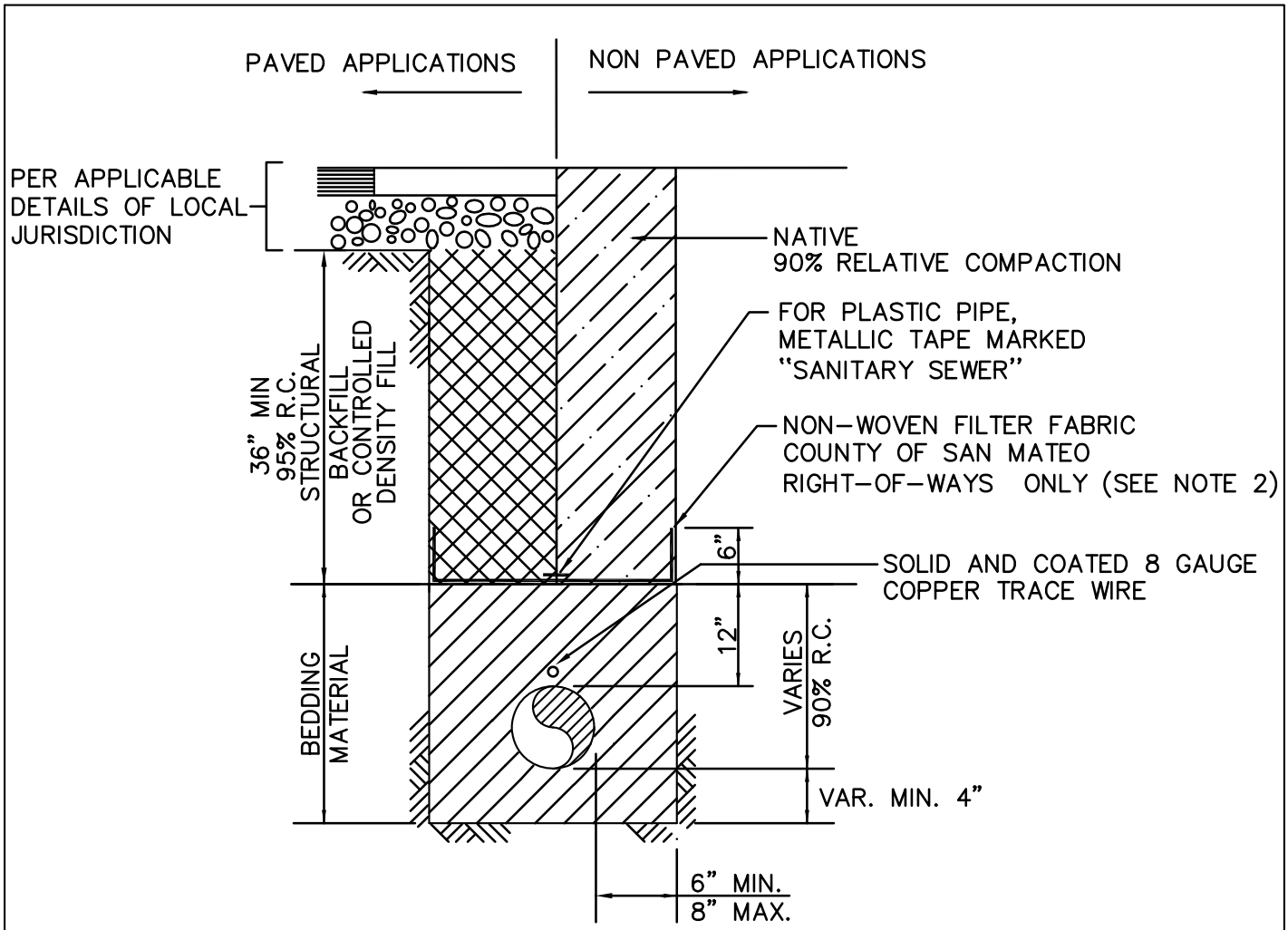

TYPICAL TRENCH SECTION

BEDDING MATERIAL

ANGULAR BEDDING MATERIAL REQUIREMENTS  
PERCENT PASSING (CRUSHED DRAIN ROCK)

| SIEVE SIZES | PERCENTAGE PASSING |
|-------------|--------------------|
| 1"          | 100                |
| 3/4"        | 90-100             |
| 3/8"        | 20-55              |
| #4          | 0-10               |
| #8          | 0-5                |

STRUCTURAL BACKFILL

STRUCTURAL BACKFILL REQUIREMENTS  
PERCENT PASSING

| SIEVE SIZES | PERCENTAGE PASSING |
|-------------|--------------------|
| 1-1/2"      | 100                |
| 3/4"        | 80-100             |
| #4          | 30-60              |
| #30         | 5-35               |
| #200        | 0-12               |

NOTES:

- 1) STRUCTURE BACKFILL AND BEDDING SHALL ALL BE VIRGIN MATERIALS.
- 2) IN COUNTY OF SAN MATEO RIGHT-OF-WAYS ONLY, NON-WOVEN FILTER FABRIC SHALL BE PLACED AS SHOWN PRIOR TO BACKFILLING ABOVE PIPE ZONE. FILTER FABRIC SHALL BE LAPPED 6" LONGITUDINALLY.

|  |          |
|--|----------|
| <b>WEST BAY</b>                              |          |
| SANITARY DISTRICT                            |          |
| EXCAVATION, BACKFILL AND SURFACE RESTORATION |          |
| APPROVED BY:                                 |          |
| /s/ - SERGIO RAMIREZ                         | 08-04-20 |
| DISTRICT MANAGER                             | DATE:    |

8



## WEST BAY SANITARY DISTRICT AGENDA ITEM 6

**To:** *Board of Directors*

**From:** *Sergio Ramirez, District Manager*

**Subject:** *District Manager's Report*

---

1) **CIP & IT Projects:**

a. **Levee Improvement Project:**

- i. F&L is continuing to work on the Environmental Impact Report. The comment period for the Public Notice of Preparation meeting has concluded.

b. **Construction Capital Improvement Projects (CIP)**

- i. Design work for Bay North and Ringwood are underway.
- ii. District Contractor has received comments re: Metal Storage Building permit.

2) **Operations and Maintenance:**

a. **Cleaning and Inspecting Large Diameter lines:**

- i. Crews are working on cleaning and televising the large diameter sewer lines; 36" From Alpine Road to the Menlo Park Pump Station at Bayfront. To date cleaning and inspections have been completed from Alpine Road to Veterans.

b. **Performance Merit Pay Program:**

- i. Staff is monitoring the goals for CCTV and Construction Dig-Ups.
- ii. Bringing next PMPP 20/21 program for consideration in September.

c. **Training:**

- i. Participating in mutual aid Trench Rescue training with Menlo Park Fire District in late August.
- ii. Working with Town of Portola Valley on their Emergency Evacuation Plan.

3) **Water Quality:**

a. **Sharon Heights Golf and Country Club:**

- i. Notice of Applicability and Notice of Operation sent to the State Water Board.
- ii. Received Reimbursement Agreement payment for July from SHGCC.

b. **Bayfront Recycled Water Plant (BRWP):**

- i. Working on Environmental Impact Report (EIR)
- ii. Met with Greystar regarding partnership
- iii. Facebook has shown interest in BRWP

4) **Administrative:**

- a. Staff is working on physical and electronic files and beginning a Pilot Scanning Project by using local Intern using the established "Part-Time Clerical Assistant" salary rate.
- b. Sent a letter in support of H.R. 7073 the bill makes Special Districts eligible for payments from the Coronavirus Relief Fund. Several Special Districts in the State are supporting the bill.

---

### Report to the District Board for the Regular Meeting of August 12, 2020

Additional information or topics may be introduced by the DM verbally during the Board meeting.



- c. Updating Detail No. 8 of the District's Standard Specification for Design and Construction. The detail addresses Excavations, Backfill, and Surface Restoration.
  - d. Solid Waste Rate Study: Agreement for a solid waste rate study this fall for 2021 rates with HF&H for approximately \$38k.
  - e. FERRF helipad to be utilized this week for spraying of invasive plants in the Bay.
- 5) **Finance:**
- a. Paid annual service debt for 2014, 2015, and 2018 bonds totaling \$2.7 million.
  - b. Paid Unfunded Accrual Liability (AUL) down by \$1.6 million per approved budget.
  - c. Paid regular Annual PERs payment of \$382,655.
  - d. Deployed Abila P.O. module in an effort to reduce paper and gain efficiencies.
- 6) **Fleet and Facilities:**
- a. **Vehicle Maintenance:**
    - i. City of Menlo Park City terminated the Vehicle Maintenance Service Agreement. District Staff has moved swiftly on finding an alternative.
- 7) **Upcoming Events:**
- a. **Board meetings:** Consider cancelling the August 26<sup>th</sup> meeting for the summer season. Next meeting would be September 9<sup>th</sup>, 2020.
- 8) **Misc./Action Items from Previous Meeting:**
- a. **West Bay SSOs:** Zero SSO for July. 2020 Total = 0. 14 months in a row w/o SSO.
  - b. **LAH Contract:** Zero SSO for July. 2 SSO in 2020. Continuing to maintain the collection system and both Publicly Owned Pump Stations.
  - c. **Town of Woodside Contract:** Cleaned entire Town and continuing to maintain High Frequency cleaning downtown and both Publicly Owned Pump Stations.
  - d. **Revenue:** Accounting for services rendered to others in FY19/20 and will report on revenue in September's financial report.
  - e. **COVID-19 Update:** Protocol Update
  - f. **YouTube Advertising Data:** Report and Chart will be available at Board meeting.

---

## Report to the District Board for the Regular Meeting of August 12, 2020

Additional information or topics may be introduced by the DM verbally during the Board meeting.



**To: Board of Directors**

**From: Sergio Ramirez, District Manager  
Jed Beyer, Water Quality Manager**

**Subject: Consideration to Approve Resolution for the Audited & Revised Sewer System Management Plan (SSMP) and Authorizing its Re-Certification for 2020**

---

### **Background**

On May 2, 2006 the State Water Resource Control Board (SWRCB) adopted the Statewide General Waste Discharge Requirements for SSOs (SSO WDR). The SSO WDR established statewide requirements for operating, maintaining, and managing a wastewater collection system. The SSO WDR applies to all public collection system agencies in California that own or operate collection systems comprised of more than one mile of pipe or sewer lines, which convey untreated wastewater to a publicly owned treatment works (POTW). The SSO WDR also mandated a statewide reporting program which requires electronic reporting of all SSOs to the SWRCB, and the preparation and implementation of a Sewer System Management Plan (SSMP). The SSO WDR requires the agency to prepare an SSMP, which is to contain eleven elements outlined in the Statewide SSO WDR.

Effective management of a wastewater collection system as defined in the SSO WDR includes:

- Maintaining or improving the condition of the collection system infrastructure in order to provide reliable service into the future.
- Cost-effectively minimizing infiltration/inflow (I/I) and providing adequate sewer capacity to accommodate design storm flows: and
- Minimizing the number and impact of SSOs that occur notwithstanding implementation of the SSMP.

The District previously completed the various SSMP elements in a manner that addressed SWRCB requirements. The District's initial SSMP was adopted under Resolution # 1642 on December 12, 2007. At that time, the Board requested staff attempt to update the SSMP annually and bring the updated document back to the Board for approval.

The purpose of the initial SSMP was to identify programs and activities for the effective management of a collection system, referred to as elements in the SSMP (noted below) that will reduce the number of SSOs. Resources and timelines were also identified to ensure the ability of the District to make these programs and activities successful in reducing SSOs. The 11 Elements of a compliant SSMP are:

- |   |  |
|---|--|
| 1. District Goals                               | 8. System Evaluation and Capacity Assurance Plan   |
| 2. Organization                                 | 9. Monitoring, Measurement & Program Modifications |
| 3. Legal Authority                              | 10. SSMP Program Audits, and                       |
| 4. Operation and Maintenance Program            | 11. Communication Plan.                            |
| 5. Design and Performance Provisions            |  |
| 6. Overflow Emergency Response Plan             |  |
| 7. Fats, Oils, and Grease (FOG) Control Program |  |

\*Note: the order of the SSMP Elements (and some titles) have been revised to be consistent with the changes in the State’s SSMP Guideline document of 2015.

The SSMP must be re-certified in the On-line SSO Database and the State Water Board form must be sent to the SWRCB.

**Analysis:**

AMConsulting was hired in 2017 to perform a thorough review of the current SSMP. The 5 year review is required per the State General Waste Discharge Requirements for Sanitary Sewer Systems. The five year analysis included the review of internal documents, several past SSMP internal audits, the District’s database and all records utilized to monitor and maintain the District’s collection system. The internal 2020 SSMP audit consists of the following updates:

- Date change to 2020 for all documents
- Updates to organizational chart
- Update Revision Log for the 2020 SSMP and OERP.

The revisions are listed in “Attachment “A”.

As required per the SSO WDR, the SSMP must be reviewed, audited and recertified every five years, or when changes have been made. This report is intended to meet that requirement.

**Fiscal Impact:**

Other than the Board's Approved Fiscal Year Budget 20/21, where it made significant capital investments to its infrastructure and programs, no other anticipated impact is expected.

**Recommendation:**

The District Manager and Water Quality Manager recommend the District Board approve the 2020 SSMP as revised and authorize the SSMP re-certification to the State Water Resource Control Board through the California Integrated Water Quality System.

Note: A clean copy of the SSMP will be available for review at the Board meeting.

**Attachments:**

SSMP Resolution

RESOLUTION NO. \_\_\_\_\_(2020)

IN THE DISTRICT BOARD OF THE WEST BAY SANITARY DISTRICT

\*\*\*\*\*

**A RESOLUTION APPROVING THE WEST BAY SANITARY DISTRICT "SEWER SYSTEM MANAGEMENT PLAN, ACCEPTING THE 2020 ANNUAL AUDIT FOR THE SSMP, AND AUTHORIZING RE-CERTIFICATION OF THE 2020 SSMP TO THE STATE WATER RESOURCES CONTROL BOARD THROUGH THE CALIFORNIA INTEGRATED WATER QUALITY SYSTEM"**

**WHEREAS**, the State Water Resource Control Board (State Water Board) adopted Water Quality Order 2006-0003-DWR which requires the District's Sewer System Management Plan (SSMP) to be audited, revised & re-certified every five years; and

**WHEREAS**, the District has performed this annual internal audit; and

**WHEREAS**, the SSMP has been revised to include the audit's recommendations; and

**WHEREAS**, the District Board has reviewed and discussed the revised SSMP in a public meeting on August 12, 2020, and

**WHEREAS**, District staff will annually submit updates of the SSMP to the District Board for approval.

**NOW, THEREFORE, BE IT RESOLVED** that the Board of Directors of the West Bay Sanitary District:

1. Approves the Sewer System Management Plan, and
2. Accepts the 2020 annual audit of the SSMP, and
3. Directs District staff to re-certify the SSMP with the State Water Resource Control Board through the California Water Quality Integrated System.

\*\*\*\*\*

Passed and adopted by the District Board of West Bay Sanitary District at a regular meeting thereof held on the 12th day of August, 2020 by the following vote:

Ayes:

Noes:

Absent:

Abstain:

---

President of the District Board of  
Directors Of the West Bay  
Sanitary District, San Mateo  
County, State of California

Attest:

---

Secretary of the District Board of Directors Of  
the West Bay Sanitary District,  
San Mateo County, State of California

THIS PAGE LEFT INTENTIONALLY BLANK



**WEST BAY SANITARY DISTRICT  
AGENDA ITEM 8**

**To: Board of Directors**

**From: Robert Scheidt, Assistant Operations Superintendent**

**Subject: Consideration to Approve Purchase of a 2020 Ford Ranger for the Water Quality Supervisor**

---

Background

The District hired a Water Quality Supervisor on May 18, 2020, He will be required to drive to multiple recycle water facilities, the District office, and participate in the on-call rotation.

Analysis

The Board approved \$50,000 for FY 19/20 Budget to purchase a New 2020 Ford Ranger. The retail price for the 2020 Ford Ranger is \$48,397.75 (see attached Ford quote.). The Houston Galveston Area Counsel or HGAC similar to National Auto Fleet Group (NAFG) allows the District to take advantage of a cooperative bid process and pricing which the District has used on numerous occasions. The District has received a price through the National Auto Fleet Group for \$44,300.34 a savings of approximately \$4,097.41 (see attached quote.).

Fiscal Impact

Fiscal impact is \$44,300.34 plus \$5,699.66 for accessories such as lighting, radio, traffic control equipment for the vehicle to the Capital Asset Fund. Funds proposed to be used in FY20/21 using the Equipment Replacement Fund are not to exceed a total of \$50,000.00

Recommendation

The Assistant Operations Superintendent requests the Board for consideration to approve the purchase the 2020 Ford Ranger out of the Capital Asset Expenditures Budget FY20/21

Attachments: Ford Competitive Price Quote  
NAFG Quote





# 2020 Ranger LARIAT

Have vehicle questions?



Representative exterior image shown. Actual exterior may vary. See your dealer for details.

## Payment

- Base MSRP<sup>S1</sup> \$38,675
- Total of Options<sup>S4</sup> \$4,685
- Destination Charges<sup>S17</sup> \$1,195
- Acquisition Fee<sup>S18</sup> \$645
- Total MSRP<sup>S16</sup> \$45,200
- Available Incentives<sup>S3</sup> -\$900

RCL Customer Cash  
 Program #50528: For Red Carpet Lease incentives \$900.00, take new retail delivery from dealer stock by 08/03/2020. See dealer for complete details.  
 Amount: \$900, Offer Valid: Jul 7, 2020-Aug 3, 2020

Estimated Net Price<sup>S5</sup>

\$44,300  
 + \$4,097.75 TAX  
 \$48,397.75

7/15/2020

2020 Ford Ranger - Build & Price

\$387 Monthly Payment<sup>30</sup> Lease based on \$4,456 down payment, 36 month term and 10,500 mileage, \$0 trade-in-value

## Dealer Information

Towne Ford Sales  
1601 El Camino Real  
Redwood City, CA 94063

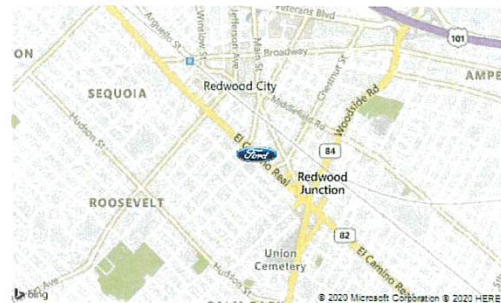

Showing the nearest Authorized Dealer for the entered zip code

## Model

- 2020 Ford Ranger LARIAT SuperCrew®, 5' Box, 4x4, 2.3L EcoBoost Engine with Auto Start-Stop Technology, Electronic Ten-Speed Automatic Transmission, 3.73 Open Style Axle Ratio **\$38,675**

## Paint<sup>S4</sup>

- Oxford White **\$0**

## Packages<sup>S4</sup>

- 501A **\$2,005**
- Sport Appearance Package **\$895**
- Trailer Tow Package **\$495**
- Technology Package - 501A **\$0**

## Exterior<sup>S4</sup>

- 17" Magnetic-Painted Aluminum Wheels **\$0**
- Bedliner - Tough Bed Spray-in **\$495**
- Windshield Wiper De-icer **\$0**
- Manual-Sliding Rear-window with Privacy Glass and Defrost **\$0**
- 5" Running Boards - Black **\$635**
- Rain-Sensing Wipers **\$0**

- Remote Start **\$0**
- Adaptive Cruise Control **\$0**
- Perimeter Anti-Theft Alarm **\$0**
- Power-folding, Power Glass with Heat, Turn Signal Indicator, Security Approach Lamps and Body-color Skull Cap Sideview Mirrors **\$0**
- 3.73 Open Style Differential Axle **\$0**
- 255/65R17 A/T BSW Tires **\$0**

## Interior<sup>S4</sup>

- Ebony **\$0**
- Front Leather Seating Surfaces **\$0**
- Dual-Zone Electronic Climate Control **\$0**
- Floor Liner - Tray Style **\$160**
- Carpet Flooring with Floor Mats **\$0**
- Auto-Dimming Rearview Mirror **\$0**
- 8-Way Power Driver and Passenger Heated Seats **\$0**
- Leather-Wrapped Steering Wheel and Shifter **\$0**
- B&O Sound System by Bang & Olufsen with HD Radio™ **\$0**
- SYNC® 3 **\$0**
- SiriusXM Satellite Radio **\$0**

## Standard Features

---

### Exterior Features

- Autolamp - automatic on/off headlamps
- Bumper, Front: Steel, Frame-Mounted
- Bumper, Front - Body-Color
- Bumper, Rear: Steel
- Bumper, Rear - Body-Color
- Cargo lamp, integrated with center high-mounted stop lamp (CHMSL) - LED
- Daytime Running Lamps - LED
- Easy Fuel® capless fuel filler
- Headlamps - LED
- Fog lamps - LED
- Grille - Chrome Bar with Chrome Surround
- Hooks - Front Tow, two (4x2)
- Hooks - Front Tow, two (4x4)
- Hooks - cargo box tie-down (4)
- Handles, door and tailgate - Body-Color
- Exhaust - Single Rear
- Side Mirrors - Power-Folding, Dual Power Glass with Heat, Integrated Turn Signal & Security Approach Lights
- Side Mirrors, Skull Caps - Body-Color
- Tailgate - Power Locking
- Wheel-lip Moldings - Body Color
- Spare Tire Carrier - Rear underframe
- Reverse Sensing System
- Forward Sensing System

### Interior Features

- Dual-Zone Electronic Automatic Temperature Control
- 110-volt Power Outlet - Rear Flow-Through Console
- Dual 4.2" Productivity Screens
- 8" LCD Capacitive Touchscreen in Center Stack with SYNC® 3
- Pre-Collision Assist with Automatic Emergency Braking
- BLIS® (Blind Spot Information System) with Cross-Traffic Alert and Trailer Monitoring
- Ambient lighting
- Automatic high beams
- Color-coordinated carpet with carpeted floor mats
- Floor Mats - Carpeted with Nubuck edge
- Locking Glove Box
- Cruise control
- Delayed accessory power
- Dome light
- Fade-to-off interior lighting
- Flow-through center console with floor shifter
- Grab handles (A-Pillar) - Front, Passenger-side
- Horn, dual-note
- Intermittent windshield wipers

- Window - Rear - Manual sliding glass with privacy tint and defroster
- Windows - First-row - Power, one-touch up/down driver side
- Windows - Second-row - Fixed (SuperCab)
- Windows - Second-row - Power (SuperCrew®)

- Lane-Keeping System
- MyKey®
- Outside temperature display
- Overhead console
- Power Door Locks
- Intelligent access with push-button start
- Powerpoint, 12v - Front, Two (2)
- Powerpoint, 12v - Rear
- Rearview mirror, Auto-dimming
- Steering wheel - Leather-wrapped
- Steering wheel, manual tilt/telescoping
- Visors with driver- and passenger-side illuminated, covered mirrors
- SiriusXM® Satellite Radio
- Speakers - 6 Audio Speakers
- FordPass Connect™ with 4G LTE Wi-Fi hotspot
- 911 Assist®
- Applink®
- SYNC® 3
- Seats - Front - 8-way power driver and passenger heated seats with power lumbar
- Seats - Rear - flip up bench with underseat storage (SuperCrew®)
- Heated front leather seating surfaces bucket seats and rear leather-trimmed bench seats (SuperCrew® Only)

## Packages

- Ford Co-Pilot360™ Technology
- Equipment Group 500A

## Power and Handling

- 2.3L EcoBoost® Engine with Auto Start Stop Technology
- Auto Start-Stop Technology
- Electronic 10-speed Transmission with Tow/Haul Mode
- SelectShift® Automatic Transmission
- Fuel Tank - 18-gallon
- 4x2
- Electronic-Shift-On-the-Fly (ESOF) with Neutral Towing Capability (4x4 only)
- Axle, Front - Independent Front Suspension
- Brakes - 4-Wheel Disc with ABS
- Electronic Power-Assist Steering (EPAS) Electric Motor
- Fully boxed frame
- Suspension - Front - Independent short long arm and tubular stabilizer bar
- Suspension - Rear - Hotchkiss-type non-independent live, leaf springs
- Shock Absorbers, Front - Gas
- Shock Absorbers, Rear - Gas
- Springs, Front - Coil
- Springs, Rear - Leaf, two-stage linear rate
- Trailer Sway Control
- Trailer Towing - 4-pin wiring, ball mounting provisions in rear bumper



- 18-inch Machined Aluminum Wheel w/Stealth Gray Pockets
- 265/60R18 BSW all-season tires (4x2)
- 265/60R18 BSW all-terrain tires (4x4)

## Safety

- Rear View Camera
- AdvanceTrac<sup>®</sup> with Roll Stability Control<sup>™</sup> (RSC<sup>®</sup>)
- Airbags - Front, Driver and passenger
- Airbags - Front, Driver and passenger seat-mounted side
- Airbags - Safety Canopy<sup>®</sup> side curtains
- Curve Control
- Four-Wheel Anti-Lock Brakes
- Child Seat Tether Anchors
- Safety belts - Active Restraint System (ARS), three-point manual lap/shoulder belts with height adjusters, pretensioners and energy management retractors on outside front positions
- Child-proof rear-door-locks (SuperCrew<sup>®</sup>)
- Tire Pressure Monitoring System (TPMS)
- Perimeter anti-theft alarm
- Remote Keyless Entry System
- SecuriLock<sup>®</sup> passive anti-theft system
- SOS Post-Crash Alert System<sup>™</sup>
- Spare tire and wheel lock

## Accessories

---

Your Configuration: 2020 Ford Ranger LARIAT SuperCrew<sup>®</sup>, 5' Box, 4x4, 2.3L EcoBoost Engine with Auto Start-Stop Technology, Electronic Ten-Speed Automatic Transmission, 3.73 Open Style Axle Ratio

Pricing shown for Zip code 94025 as of July 15, 2020 <sup>S2</sup>

---

Note. Information is provided on an "as is" basis and could include technical, typographical or other errors. Ford makes no warranties, representations, or guarantees of any kind, express or implied, including but not limited to, accuracy, currency, or completeness, the operation of the Site, the information, materials, content, availability, and products. Ford reserves the right to change product specifications, pricing and equipment at any time without incurring obligations. Your Ford dealer is the best source of the most up-to-date information on Ford vehicles.

Disclosures through S18 apply to Search Dealer Inventory, Request A Quote, Get An Internet Price, Get A Quote, Let Us Find It For You, Build & Price and Incentives & Offers.

### S1.

Manufacturer's Suggested Retail Price (also referred to as "MSRP", "Base MSRP", "Base Price" or the "Starting At" price), excludes destination/delivery charge, taxes, title, license, and registration and/or electronic filing fees, dealer fees, and total of options.

For authenticated AXZ Plan customers, the price displayed may represent Plan pricing. Not all AXZ Plan customers will qualify for the Plan pricing shown and not all offers or incentives are available to AXZ Plan customers.

### S2.

Images shown are for information purposes only, and may not necessarily represent the configurable options selected or available on the vehicle. We cannot be responsible for typographical or other errors, including data transmission, display, or software errors, that may appear on the site.

### S3.

Offers shown may not be available to all customers. Incentives lists are examples of offers available at the time of posting and are subject to change and expiration. Not all incentives can be redeemed together. To take advantage of rebates, incentives and/or financing offers you must take new retail delivery from dealer stock by the expiration date noted. Not all buyers will qualify for Ford Credit financing or other offers. Restrictions apply. See your local dealer for complete details.

S4.

The Option Package price and monthly payment displayed is for illustration purposes, only. Prices and monthly payments may vary based on features included in package, financing terms and availability. Some Options are not available separately. Not all Options or Option Packages are available on all vehicles. See your local dealer for details.

S5. Estimated Net Price is the Total Manufacturer's Suggested Retail Price ("Total MSRP") minus any available offers and/or incentives. Incentives may vary. Excludes taxes, title, and registration fees. For authenticated AXZ Plan customers, the price displayed may represent Plan pricing. Not all AXZ Plan customers will qualify for the Plan pricing shown and not all offers or incentives are available to AXZ Plan customers.

S6.

The payment estimator will calculate a monthly payment based on the MSRP of the vehicle you have configured, including the dealer-installed accessories. For authenticated AXZ Plan customers, the price displayed may represent Plan pricing. Not all AXZ Plan customers will qualify for the Plan pricing shown. Actual monthly payment is based on a variety of factors, including differing financing or leasing terms, accessory prices and installation costs. Financing payment calculations are estimates only, and are based on amount of down payment, APR and term. Lease payment calculations are estimates only, and are based on an annual mileage calculation determined by your dealer. A charge is assessed for any mileage driven that exceeds this limit. Lessee is responsible for \$395 lease Disposition Fee in select states. Not all buyers will qualify for financing or a lease. Contact your local Ford or Lincoln Dealer for details.

S7.

While dealer inventory is generally updated on a daily basis, there are no guarantees that the inventory shown will be available at the dealership. Mid-model-year manufacturing changes, as well as dealer-added accessories on the actual vehicle may differ from the options and features listed. Vehicles that are identified as 'Exact Matches' may have a different price or different features not represented on the site. We make every effort to provide you with the most accurate, up-to-date information, however, only your local Ford dealer can provide you with information regarding actual vehicle availability.

S8.

Dealer Accessories are defined as items that do not appear on the factory window sticker that are installed by a Ford or Lincoln Dealers. Actual Prices for all accessories may vary and depend upon your dealer. Prices DO NOT include installation or painting, which may be required for particular items. Please check with your authorized dealer for complete pricing accuracy for all accessories and parts.

Genuine Ford Accessories will be warranted for whichever provides you the greatest benefit: 12 months or 12,000 miles (whichever occurs first) or the remainder of your Bumper-to-Bumper 3-year/36,000-mile New Vehicles Warranty. Contact your local Ford, Lincoln or Mercury dealer for details and a copy of the limited warranty.

Ford Licensed Accessories (FLA) are warranted by the accessories manufacturer's warranty. Contact your Ford, Lincoln or Mercury Dealer for details regarding the manufacturer's limited warranty and/or a copy of the FLA product limited warranty offered by the accessory manufacturer.

Most Ford Racing Performance Parts are sold with no warranty. Ford Racing Performance Parts are sold "As Is", "With All Faults", "As They Stand" and without any express warranty whatsoever, unless otherwise expressly designated herein. To determine which parts come with a warranty from the original manufacturer, or from Ford Racing, please contact the Ford Racing Techline at (800) FORD788.

S9.

The "Trade-In Value" of your vehicle is an estimate, only, and many factors that cannot be assessed without a physical inspection of the vehicle may affect actual value. For purposes of this website, we use the services of a third-party vendor to provide Trade-In Value calculations. While we believe this information is reliable, we are not responsible for and do not guarantee the accuracy or reliability of the information. Please see your local Ford dealer for information regarding actual trade-in availability and value.

S10.

AXZ Plan pricing, including AXZ Plan option pricing, is exclusively for eligible Ford Motor Company employees, friends and family-members of eligible employees, and Ford Motor Company eligible partners. Restrictions apply. See your Ford or Lincoln dealer for complete details and qualifications. Ford Motor Company reserves the right to modify the terms of AXZ Plan pricing or availability at any time. Some dealers may also chose not to participate in plan pricing Contact your local dealer to determine final pricing.

S11.

EPA estimated city/highway mpg based on base engine/transmission configuration. Actual mileage will vary.

S12.

Towing - Properly equipped.

S13.

For Dealer Ordered vehicles, the vehicle has already been ordered by the dealer and is in the process of being manufactured by the factory. If you are interested in the vehicle marked "Dealer Ordered", contact the dealership for a delivery estimate.

S14. The "estimated selling price" is for estimation purposes only and the figures presented do not represent an offer that can be accepted by you. See your local dealer for vehicle availability and actual price. The Estimated Selling Price shown is the Base



MSRP plus destination charges and total of options, but does not include service contracts, insurance or any outstanding prior credit balance. Does not include tax, title or registration fees. It also includes the acquisition fee. For Commercial Lease product, upfit amounts are included.

The "estimated capitalized cost" is for estimation purposes only and the figures presented do not represent an offer that can be accepted by you. See your local dealer for vehicle availability, actual price, and financing options. Estimated Capitalized Cost shown is the Base MSRP plus destination charges and total of options, but does not include service contracts, insurance or any outstanding prior credit balance. Does not include tax, title or registration fees. It also includes the acquisition fee. For Commercial Lease product, upfit amounts are included.

S15. The "amount financed" is for estimation purposes only and the figures presented do not represent an offer that can be accepted by you. See your local dealer for vehicle availability, actual price, and financing options. Estimated Amount Financed is the amount used to determine the Estimated Monthly Payment. It is equal to the Estimated Selling Price of the vehicle less Down Payment, Available Incentives and Net Trade-in Amount.

The "adjusted capitalized cost" is for estimation purposes only and the figures presented do not represent an offer that can be accepted by you. See your local dealer for vehicle availability, actual price, and financing options. Estimated Adjusted Capitalized Cost is the amount used to determine the Estimated Monthly Payment. It is equal to the Estimated Capitalized Cost less Down Payment, Available Incentives, and Net Trade-in Amount.

S16.

Total MSRP is Base MSRP plus options, destination and delivery charges. Excludes taxes, title, and registration fees.

S17.

Destination Charges are associated with getting the vehicle from the manufacturer to the dealership. Prices listed are MSRP and are based on information updated on this website from time to time.

S18. Acquisition Fee is a charge paid by the lessee to Ford Credit to help cover the cost of acquiring and servicing the account.

Note2.

**For Manufacturer Specific Disclosures See Below**

1.

Starting MSRP excludes destination/delivery charge, taxes, title and registration. Optional equipment not included. Starting A, Z and X Plan price is for qualified, eligible customers and excludes document fee, destination/delivery charge, taxes, title and registration. Not all vehicles qualify for A, Z or X Plan. All Mustang Shelby GT350 and Shelby GT350R prices exclude gas guzzler tax.

2.

EPA-estimated city/hwy mpg. See fueleconomy.gov for fuel economy of other engine/transmission combinations. Actual mileage will vary. MPGe is the EPA equivalent measure of gasoline fuel efficiency for electric mode operation.

## DISCLOSURES ( )

FF





# National Auto Fleet Group

A Division of Chevrolet of Watsonville  
490 Auto Center Drive, Watsonville, CA 95076  
(855) 289-6572 • (831) 480-8497 Fax  
Fleet@NationalAutoFleetGroup.com

7/7/2020

Quote ID: **13907**

Order Cut Off Date: **TBA**

Mr Bob Scheidt  
West Bay Sanitary District  
500 Laurel St.  
Menlo Park, California, 94025



Dear Bob Scheidt,

National Auto Fleet Group is pleased to quote the following vehicle(s) for your consideration.

**One (1) New/Unused (2020 Ford Ranger (R4F) LARIAT 4WD SuperCrew 5' Box 126.8" WB, factory order )** and delivered to your specified location, each for

|                | One Unit (MSRP) | One Unit    | Total % Savings | Total Savings |
|----------------|-----------------|-------------|-----------------|---------------|
| Contract Price | \$44,815.00     | \$40,541.50 | 9.536 %         | \$4,273.50    |
| factory order  |                 | \$0.00      |                 |               |
| Tax (9.2500 %) |                 | \$3,750.09  |                 |               |
| Tire fee       |                 | \$8.75      |                 |               |
| Total          |                 | \$44,300.34 |                 |               |

- per the attached specifications.

This vehicle(s) is available under the **Sourcewell (Formerly Known as NJPA) Contract 120716-NAF** . Please reference this Contract number on all purchase orders to National Auto Fleet Group. Payment terms are Net 20 days after receipt of vehicle.

Thank you in advance for your consideration. Should you have any questions, please do not hesitate to call.

Sincerely,

Jesse Cooper  
Account Manager  
Email: Fleet@NationalAutoFleetGroup.com  
Office: (855) 289-6572  
Fax: (831) 480-8497

Quoting Department  
Account Manager  
Fleet@NationalAutoFleetGroup.com  
(855) 289-6572



GMC

**In order to Finalize your Quote, please submit this purchase packet to your governing body for Purchase Order Approval. Once you issue a Purchase Order please send by:**

**Fax: (831) 480-8497**

**Mail: National Auto Fleet Group  
490 Auto Center Drive  
Watsonville, CA 95076**

**Email: Fleet@NationalAutoFleetGroup.com**

**We will then send a W-9 if you need one**

**Please contact our main office with any questions:  
1-855-289-6572**

## Vehicle Configuration Options

| ENGINE               |  |
|----------------------|--|
| Code                 | Description  |
| 99H                  | ENGINE: 2.3L ECOBOOST, -inc: auto start-stop technology (STD)  |
| TRANSMISSION         |  |
| Code                 | Description  |
| 44U                  | TRANSMISSION: ELECTRONIC 10-SPEED SELECTSHIFT AUTO, (STD)  |
| WHEELS               |  |
| Code                 | Description  |
| 64D                  | WHEELS: 17" MAGNETIC PAINTED ALUMINUM  |
| TIRES                |  |
| Code                 | Description  |
| ___                  | TIRES: 17"   |
| PRIMARY PAINT        |  |
| Code                 | Description  |
| YZ                   | OXFORD WHITE   |
| PAINT SCHEME         |  |
| Code                 | Description  |
| ___                  | STANDARD PAINT   |
| SEAT TYPE            |  |
| Code                 | Description  |
| DH                   | EBONY, FRONT HEATED LEATHER-TRIMMED BUCKET SEATS, -inc: power 8-way adjustable driver/passenger w/power lumbar, flow-through console and floor shift |
| AXLE RATIO           |  |
| Code                 | Description  |
| X73                  | ELECTRONIC-LOCKING REAR DIFFERENTIAL   |
| ADDITIONAL EQUIPMENT |  |
| Code                 | Description  |
| 53R                  | TRAILER TOW PACKAGE, -inc: towing capability up to TBD lbs and 4-pin/7-pin wiring harness, Class IV Trailer Hitch Receiver                           |
| 67J                  | TECHNOLOGY PACKAGE, -inc: forward sensing system, Adaptive Cruise Control, Navigation  |



|                       |  |
|-----------------------|--|
| 76E                   | SPORT APPEARANCE PACKAGE, -inc: Sport Box Decal, Wheels: 17" Magnetic Painted Aluminum, Black Grille w/Magnetic Surround & Bars, Tires: 17", Exposed Front Tow Hooks, Magnetic Wheel-Lip Molding   |
| 153                   | FRONT LICENSE PLATE BRACKET, -inc: Standard in states requiring 2 license plates and optional to all others  |
| 86S                   | TOUGH BED SPRAY-IN BEDLINER  |
| 18Y                   | 5" RECTANGULAR BLACK RUNNING BOARDS  |
| —                     | RADIO: B&O SOUND SYSTEM BY BANG & OLUFSEN, -inc: 10 high-performance speakers and HD Radio   |
| <b>OPTION PACKAGE</b> |  |
| <b>Code</b>           | <b>Description</b>   |
| 501A                  | EQUIPMENT GROUP 501A MID, -inc: Rain-Sensing Wipers, Remote Start, Technology Package, forward sensing system, Adaptive Cruise Control, Navigation, Windshield Wiper De-Icer, Radio: B&O Sound System by Bang & Olufsen, 10 high-performance speakers and HD Radio |

## 2020 Fleet/Non-Retail Ford Ranger LARIAT 4WD SuperCrew 5' Box 126.8" WB

### WINDOW STICKER

2020 Ford Ranger LARIAT 4WD SuperCrew 5' Box 126.8" WB

| CODE           | MODEL  | MSRP        |
|----------------|--|-------------|
| R4F            | 2020 Ford Ranger LARIAT 4WD SuperCrew 5' Box 126.8" WB   | \$38,675.00 |
| <b>OPTIONS</b> |  |             |
| 99H            | ENGINE: 2.3L ECOBOOST, -inc: auto start-stop technology (STD)  | \$0.00      |
| 44U            | TRANSMISSION: ELECTRONIC 10-SPEED SELECTSHIFT AUTO, (STD)  | \$0.00      |
| 64D            | WHEELS: 17" MAGNETIC PAINTED ALUMINUM  | INC         |
| —              | TIRES: 17"   | \$0.00      |
| YZ             | OXFORD WHITE   | \$0.00      |
| —              | STANDARD PAINT   | \$0.00      |
| DH             | EBONY, FRONT HEATED LEATHER-TRIMMED BUCKET SEATS, -inc: power 8-way adjustable driver/passenger w/power lumbar, flow-through console and floor shift   | \$0.00      |
| X73            | ELECTRONIC-LOCKING REAR DIFFERENTIAL   | \$420.00    |
| 53R            | TRAILER TOW PACKAGE, -inc: towing capability up to TBD lbs and 4-pin/7-pin wiring harness, Class IV Trailer Hitch Receiver   | \$495.00    |
| 67J            | TECHNOLOGY PACKAGE, -inc: forward sensing system, Adaptive Cruise Control, Navigation  | INC         |
| 76E            | SPORT APPEARANCE PACKAGE, -inc: Sport Box Decal, Wheels: 17" Magnetic Painted Aluminum, Black Grille w/Magnetic Surround & Bars, Tires: 17", Exposed Front Tow Hooks, Magnetic Wheel-Lip Molding   | \$895.00    |
| 153            | FRONT LICENSE PLATE BRACKET, -inc: Standard in states requiring 2 license plates and optional to all others  | \$0.00      |
| 86S            | TOUGH BED SPRAY-IN BEDLINER  | \$495.00    |
| 18Y            | 5" RECTANGULAR BLACK RUNNING BOARDS  | \$635.00    |
| —              | RADIO: B&O SOUND SYSTEM BY BANG & OLUFSEN, -inc: 10 high-performance speakers and HD Radio   | INC         |
| 501A           | EQUIPMENT GROUP 501A MID, -inc: Rain-Sensing Wipers, Remote Start, Technology Package, forward sensing system, Adaptive Cruise Control, Navigation, Windshield Wiper De-Icer, Radio: B&O Sound System by Bang & Olufsen, 10 high-performance speakers and HD Radio | \$2,005.00  |

Please note selected options override standard equipment

|                                    |                    |
|------------------------------------|--------------------|
| <b>SUBTOTAL</b>                    | <b>\$43,620.00</b> |
| Advert/ Adjustments                | \$0.00             |
| Manufacturer Destination Charge    | \$1,195.00         |
| <b>TOTAL PRICE</b>                 | <b>\$44,815.00</b> |
| Est City: N/A MPG                  |                    |
| Est Highway: N/A MPG               |                    |
| Est Highway Cruising Range: N/A mi |                    |

Any performance-related calculations are offered solely as guidelines. Actual unit performance will depend on your operating conditions.



## Standard Equipment

### MECHANICAL

|   |
|---|
| Engine: 2.3L EcoBoost -inc: auto start-stop technology                                    |
| Transmission: Electronic 10-Speed SelectShift Auto  |
| 3.73 Axle Ratio   |
| GVWR: 6,050 lbs   |
| 50-State Emissions System   |
| Transmission w/Driver Selectable Mode   |
| Electronic Transfer Case  |
| Part-Time Four-Wheel Drive  |
| 150 Amp Alternator  |
| 80-Amp/Hr 800CCA Maintenance-Free Battery w/Run Down Protection                           |
| Towing Equipment -inc: Trailer Sway Control   |
| Trailer Wiring Harness  |
| 1560# Maximum Payload   |
| Gas-Pressurized Shock Absorbers   |
| Front Anti-Roll Bar   |
| Electric Power-Assist Speed-Sensing Steering  |
| 18 Gal. Fuel Tank   |
| Single Stainless Steel Exhaust  |
| Auto Locking Hubs   |
| Short And Long Arm Front Suspension w/Coil Springs  |
| Leaf Rear Suspension w/Leaf Springs   |
| 4-Wheel Disc Brakes w/4-Wheel ABS, Front Vented Discs, Brake Assist and Hill Hold Control |

### EXTERIOR

|  |
|--|
| Wheels: 18" Machined Alum w/Stealth Gray Pockets   |
| Tires: P265/60R18 A/T BSW  |
| Regular Box Style  |
| Steel Spare Wheel  |
| Full-Size Spare Tire Stored Underbody w/Crankdown  |
| Clearcoat Paint  |
| Body-Colored Front Bumper w/Body-Colored Rub Strip/Fascia Accent and 2 Tow Hooks                 |
| Body-Colored Rear Step Bumper  |
| Black Side Windows Trim and Black Front Windshield Trim  |
| Body-Colored Wheel Well Trim   |
| Body-Colored Door Handles  |
| Body-Colored Power Heated Side Mirrors w/Convex Spotter, Power Folding and Turn Signal Indicator |

|  |
|--|
| Sliding Rear Window w/Defroster  |
| Variable Intermittent Wipers   |
| Deep Tinted Glass  |
| Galvanized Steel/Aluminum Panels   |
| Chrome Grille  |
| Tailgate Rear Cargo Access   |
| Tailgate/Rear Door Lock Included w/Power Door Locks  |
| Cargo Lamp w/High Mount Stop Light   |
| Front Fog Lamps  |
| Perimeter/Approach Lights  |
| LED Brakelights  |
| Autolamp Fully Automatic Projector Beam Led Low/High Beam Auto High-Beam Daytime Running Lights Preference Setting Headlamps w/Delay-Off |

**ENTERTAINMENT**

|  |
|--|
| Radio: AM/FM Stereo -inc: Bluetooth pass thru and 1 USB port   |
| Radio w/Seek-Scan, Clock and Speed Compensated Volume Control  |
| Integrated Roof Antenna  |
| SiriusXM Satellite Radio -inc: a 6-month prepaid subscription, Service is not available in Alaska and Hawaii, Subscriptions to all SiriusXM services are sold by SiriusXM after trial period, If you decide to continue service after your trial, the subscription plan you choose will automatically renew thereafter and you will be charged according to your chosen payment method at then-current rates, Fees and taxes apply, To cancel you must call SiriusXM at 1-866-635-2349, See SiriusXM customer agreement for complete terms at www.siriusxm.com, All fees and programming subject to change, Sirius, XM and all related marks and logos are trademarks of Sirius XM Radio Inc |

**INTERIOR**

|  |
|--|
| Driver Seat  |
| Passenger Seat   |
| Full Folding Bench Front Facing Fold-Up Cushion Rear Seat  |
| Manual Tilt/Telescoping Steering Column  |
| Gauges -inc: Speedometer, Odometer, Voltmeter, Oil Pressure, Engine Coolant Temp, Inclinator, Transmission Fluid Temp, Trip Odometer and Trip Computer |
| Power Rear Windows   |
| FordPass Connect 4G Mobile Hotspot Internet Access   |
| Leather Steering Wheel   |
| Front Cupholder  |
| Rear Cupholder   |
| Compass  |
| Remote Keyless Entry w/Integrated Key Transmitter, Illuminated Entry and Panic Button  |
| Proximity Key For Doors And Push Button Start  |



|  |
|--|
| Garage Door Transmitter  |
| Cruise Control w/Steering Wheel Controls   |
| HVAC -inc: Underseat Ducts   |
| Voice Activated Dual Zone Front Automatic Air Conditioning   |
| Illuminated Locking Glove Box  |
| Full Cloth Headliner   |
| Interior Trim -inc: Piano Black Instrument Panel Insert, Cabback Insulator and Chrome Interior Accents   |
| Leather Door Trim Insert   |
| Leather Gear Shifter Material  |
| Front Heated Leather-Trimmed Bucket Seats -inc: power 8-way adjustable driver/passenger w/power lumbar, flow-through console and floor shift   |
| Day-Night Auto-Dimming Rearview Mirror   |
| Driver And Passenger Visor Vanity Mirrors w/Driver And Passenger Illumination  |
| 3 12V DC Power Outlets   |
| Full Overhead Console w/Storage, 3 12V DC Power Outlets and 1 AC Power Outlet  |
| Fade-To-Off Interior Lighting  |
| Front And Rear Map Lights  |
| Full Carpet Floor Covering -inc: Carpet Front And Rear Floor Mats  |
| Pickup Cargo Box Lights  |
| Smart Device Remote Engine Start   |
| Tracker System   |
| FOB Controls -inc: Cargo Access  |
| SYNC 3 -inc: enhanced voice recognition communications and entertainment system, 8" LCD capacitive touchscreen in center stack w/swipe capability, pinch-to-zoom capability included w/available voice-activated touchscreen navigation system, AppLink, 911 Assist, Apple CarPlay and Android Auto compatibility and 2 smart-charging USB ports, Note: SYNC AppLink lets you control some of your favorite compatible mobile apps w/your voice, It is compatible w/select smartphone platforms, Commands may vary by phone and AppLink software |
| Instrument Panel Bin, Dashboard Storage, Driver / Passenger And Rear Door Bins and 2nd Row Underseat Storage   |
| Power 1st Row Windows w/Driver 1-Touch Up/Down   |
| Delayed Accessory Power  |
| Power Door Locks w/Autolock Feature  |
| Trip Computer  |
| Analog Display   |
| Systems Monitor  |
| Redundant Digital Speedometer  |
| Outside Temp Gauge   |
| Manual w/Tilt Front Head Restraints and Manual Adjustable Rear Head Restraints   |
| 1 Seatback Storage Pocket  |
| Front Center Armrest and Rear Center Armrest   |
| Securilock Anti-Theft Ignition (pats) Engine Immobilizer   |

|  |
|--|
| Perimeter Alarm                              |
| 3 12V DC Power Outlets and 1 AC Power Outlet |

**SAFETY**

|   |
|---|
| AdvanceTrac w/Roll Stability Control Electronic Stability Control (ESC) And Roll Stability Control (RSC)                                  |
| ABS And Driveline Traction Control  |
| Side Impact Beams   |
| Dual Stage Driver And Passenger Seat-Mounted Side Airbags   |
| Ford Co-Pilot360 - Blind Spot Information System (BLIS) Blind Spot  |
| Ford Co-Pilot360 - Pre-Collision Assist with Automatic Emergency Braking (AEB) and Rear Collision Warning                                 |
| Lane Keeping Alert Lane Keeping Assist  |
| Lane Keeping Alert Lane Departure Warning   |
| Front And Rear Parking Sensors  |
| Tire Specific Low Tire Pressure Warning   |
| Dual Stage Driver And Passenger Front Airbags   |
| Safety Canopy System Curtain 1st And 2nd Row Airbags  |
| Airbag Occupancy Sensor   |
| Mykey System -inc: Top Speed Limiter, Audio Volume Limiter, Early Low Fuel Warning, Programmable Sound Chimes and Beltminder w/Audio Mute |
| Rear Child Safety Locks   |
| Outboard Front Lap And Shoulder Safety Belts -inc: Rear Center 3 Point, Height Adjusters and Pretensioners                                |
| Dynamic Hitch Assist Back-Up Camera   |

THIS PAGE LEFT INTENTIONALLY BLANK





**WEST BAY SANITARY DISTRICT  
AGENDA ITEM 9**

**To: Board of Directors**

**From: Robert Scheidt, Assistant Operations Superintendent**

**Subject: Consideration to Approve the Purchase of a 2020 Ford Super Duty F-350 Pump Supervisor Truck with Crane**

---

Background

The Pump Supervisor Truck Unit 217 with crane was purchased in June 2011. The truck has approximately 140k miles and has reached its useful life. The truck was deferred (FY19/20). This unit is used daily by the pump facilities group to conduct weekly pump station checks, routine maintenance, and annual P.M's as well as on-call service duties. We are asking the Board to approve a new 2020 Ford Super Duty F-350 with crane before any major breakdowns occur.

Analysis

The Board approved \$90,000 in the FY 20/21 Budget to purchase a New 2020 Ford Super Duty F-350 with crane. The retail price for the 2020 F-250 Chassis only is \$48,860.00 (see attached quote).

The Houston Galveston Area Counsel or HGAC similar to National Auto Fleet Group (NAFG) allows the District to take advantage of a cooperative bid process and pricing which the District has used on numerous occasions. The District has received a price through the National Auto Fleet Group for \$41,760.60 a savings of approximately \$7,099.40 for the chassis.

The Truck body will be built by Western Truck Fabrication as it does with all of its customized utility bodies for \$37,900.00. In addition to the chassis and utility body the tax and fees are \$7,629.11

Fiscal Impact

Fiscal impact is \$87,289.71 plus approximately \$2,710.29 for accessories such as lighting, radio, and traffic control equipment to the Capital Asset Fund. Funds proposed to be used in FY20/21 out of the Equipment Replacement Fund are not to exceed a total of \$90,000.00 per the approved budget.

---

Recommendation

The Assistant Operations Superintendent request the Board for consideration approve the purchase of the 2020 Ford Super Duty with crane out of the Capital Asset Fund Budget FY20/21.

Attachments:        Ford Competitive Price Quote  
                              NAFG Price Quote  
                              Western Truck Fabrication Quote



## 2020 Chassis Cab

### F-350 XL

Have vehicle  
questions?



Representative exterior image shown. Actual exterior may vary. See your dealer for details.

### Payment

- Base MSRP<sup>S1</sup> \$36,135
- Total of Options<sup>S4</sup> \$11,030
- Destination Charges<sup>S17</sup> \$1,695
- Total MSRP<sup>S16</sup> \$48,860
- Available Incentives<sup>S3</sup> -\$0

Estimated Net Price<sup>S5</sup>

**\$48,860**

\$0<sup>S6</sup> Lease based on \$4,886 down payment, month term and mileage, \$0 trade-in-value

## Dealer Information

Towne Ford Sales  
1601 El Camino Real  
Redwood City, CA 94063

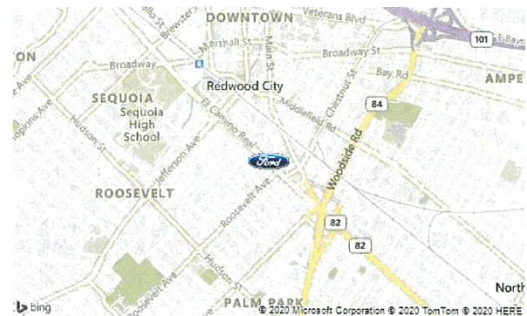

Showing the nearest Authorized Dealer for the entered zip code

## Model

- 2020 Ford Chassis Cab F-350 XL, Regular Cab, 6.7L 4 Valve OHV Power Stroke® V8 Turbo Diesel B20 Engine with Manual Push-button Engine-Exhaust Braking, TorqShift® Ten-Speed Automatic Transmission, 3.73 Non Limited Slip Axle, 145", 4X2, DRW **\$36,135**

## Paint<sup>S4</sup>

- Oxford White **\$0**

## Powertrain<sup>S4</sup>

- 6.7L 4 Valve OHV Power Stroke® V8 Turbo Diesel B20 Engine with Manual Push-button Engine-Exhaust Braking
- 4X2
- TorqShift® Ten-Speed Automatic Transmission
- Regular Cab
- 3.73 Non Limited Slip Axle
- 145"
- DRW

## Packages<sup>S4</sup>

- Extra Heavy-Service Suspension Package **\$125**

## Exterior<sup>S4</sup>

- 17" Argent Painted Steel Wheels **\$0**
- Transmission Power Take-Off Provision **\$0**
- Exterior Backup Alarm **\$140**
- Rear View Camera and Prep Kit **\$415**
- Manually Telescoping/Folding Trailer Tow with Manual Glass **\$0**
- LT245/75Rx17E BSW A/S PLU Tires **\$0**

## Interior<sup>S4</sup>

- Medium Earth Gray **\$0**
- Cloth **\$0**
- Cloth, 40/20/40 Split Bench Front Seats **\$100**
- Carpet Delete **\$0**
- Transmission Power Take-Off Provision **\$0**
- AM/FM Stereo MP3 Player **\$0**
- SYNC® **\$0**

## Standard Features

---

### Power and Handling

- Engine - 6.2L SOHC 2-valve flex-fuel V8 engine
- TorqShift® Ten-Speed Automatic With Selectable Drive Modes
- Diesel Engine-Exhaust Braking (Diesel Engine)
- DEF Tank Level Gauge (Diesel Engine)
- Alternator - 200-amp (6.2L)
- Alternator - 240-amp (7.3L)
- Alternator -220-amp (6.7L)
- Alternator -240-amp (6.7L)
- Single Battery (650 CCA 72 AH) 6.2L F-350 SRW/DRW XL
- Axle - Twin I-beam front axle with coil spring suspension - (F-350 4x2)
- Axle - Mono-beam front axle with coil spring suspension - (F-350 4X4, F-450, F-550 and F-600)
- Brakes - 4-wheel power disc brakes with Anti-lock Brake System (ABS); vacuum-boost (SRW)
- AdvanceTrac® with Roll Stability Control™ (RSC®)
- Trailer Sway Control
- Tire Pressure Monitoring System Delete (F350 SRW over 10K lbs GVWR - Fleet Only)
- Stationary Elevated Idle Control (SEIC)
- 26.5 Gallon mid-ship (F-350 SRW)
- 40 Gallon aft-axle (F-350/F-450/F-550/F-600)

### Interior Features

- Air Conditioning - Manual Temperature Control
- Dash-top tray
- Dome Lamp - door-activated instrument panel switch operated with delay
- Floor Covering - black vinyl
- Grab handles - driver and front passenger and roof ride handles; front passenger (also over rear doors with Crew Cab)
- Headliner - color coordinated cloth
- Instrumentation with tachometer and Message Center including odometer, trip odometer, distance-to-empty, average fuel economy, engine hour meter and warning messages
- Instrument Cluster - 2.3" Productivity Screen
- Map lights - dual (front and rear with Crew Cab)
- Powerpoint - Two Powerpoint in instrumentation center
- Steering Wheel - Audio Control Buttons
- Steering Wheel - Black Molded Polyurethane
- Storage - secondary glove box
- Visors - vinyl, driver w/pocket, passenger w/uncovered mirror
- Manual Tilt/telescoping steering wheel
- Upfitter Switches
- Windshield wipers - intermittent control



- Shock absorbers - Heavy Duty Gas
- Stabilizer bar - front
- Steering - power
- Steering damper
- Manual locking hubs (4x4 models only)
- Transfer Case - Electronic Shift-On-the-Fly (ESOF) 4-Wheel-Drive System (4x4 models only)
- Live Drive Power Takeoff Provision with Mobile and Stationary PTO Modes Diesel Engine
- Tough and Durable High-Strength Steel Frame
- Wheels - 17" Argent painted steel (DRW) 64K
- Wheels - 18" Argent Painted Steel with painted hub covers/center ornaments (SRW) 64F
- LT245/75R17E BSW All-Season Plus (DRW) TD8
- LT275/65R18E BSW A/S (SRW) TCH
- Audio - AM/FM Stereo, (4 Speakers regular cab, 6 speakers Super Cab and Crew Cab)
- SYNC®
- Ford Pass™ Connect
- Seats - Front, Vinyl 40/20/40 split-bench seat with center armrest, cupholder and storage
- Seats - Front, Manual Lumbar Support, Driver Side
- Seats - Rear, Vinyl 60/40 Fold-Up Bench Seat (SuperCab)
- Seats - Rear, 60/40 Flip-Up/Fold-Down Bench Seat (Crew Cab)

### Exterior Features

- Bumper, front - black painted steel with black lower air dam
- Door Handles - black
- Quad Dual-Beam Halogen Headlamps
- Grille - Black bar-style
- Mirrors - Manual Telescoping Trailer Tow with Manual Glass
- LED Roof Marker Clearance Lights
- Tow hooks - (2) front, black
- Glass - rear, solar tinted
- Window - rear, fixed, solar tinted

### Safety

- Airbags - front seat front with passenger side deactivation switch (Regular Cab and SuperCab only)
- Airbags - front seat and passenger frontal
- Airbags - Safety Canopy® System with roll-fold side-curtain airbags
- Belt-Minder®, chime and flashing warning light on instrument cluster if belts not buckled
- Child tethers (Regular Cab, front passenger and all rear seating positions)
- Seat Belts - color coordinated with height adjustment (front outboard seating positions only)
- SOS Post Crash Alert System
- Autolamp (Auto On/Off Headlamps) with Rainlamp Wiper Activated Headlamps

### Packages

---

Your Configuration: 2020 Ford Chassis Cab F-350 XL, Regular Cab, 6.7L 4 Valve OHV Power Stroke® V8 Turbo Diesel B20 Engine with Manual Push-button Engine-Exhaust Braking, TorqShift® Ten-Speed Automatic Transmission, 3.73 Non Limited Slip Axle, 145", 4X2, DRW  
Pricing shown for Zip code 94025 as of July 28, 2020 <sup>S2</sup>

---

Note. Information is provided on an "as is" basis and could include technical, typographical or other errors. Ford makes no warranties, representations, or guarantees of any kind, express or implied, including but not limited to, accuracy, currency, or completeness, the operation of the Site, the information, materials, content, availability, and products. Ford reserves the right to change product specifications, pricing and equipment at any time without incurring obligations. Your Ford dealer is the best source of the most up-to-date information on Ford vehicles.

**Disclosures through S18 apply to Search Dealer Inventory, Request A Quote, Get An Internet Price, Get A Quote, Let Us Find It For You, Build & Price and Incentives & Offers.**

S1.

Manufacturer's Suggested Retail Price (also referred to as "MSRP", "Base MSRP", "Base Price" or the "Starting At" price), excludes destination/delivery charge, taxes, title, license, and registration and/or electronic filing fees, dealer fees, and total of options.

For authenticated AXZ Plan customers, the price displayed may represent Plan pricing. Not all AXZ Plan customers will qualify for the Plan pricing shown and not all offers or incentives are available to AXZ Plan customers.

S2.

Images shown are for information purposes only, and may not necessarily represent the configurable options selected or available on the vehicle. We cannot be responsible for typographical or other errors, including data transmission, display, or software errors, that may appear on the site.

S3.

Offers shown may not be available to all customers. Incentives lists are examples of offers available at the time of posting and are subject to change and expiration. Not all incentives can be redeemed together. To take advantage of rebates, incentives and/or financing offers you must take new retail delivery from dealer stock by the expiration date noted. Not all buyers will qualify for Ford Credit financing or other offers. Restrictions apply. See your local dealer for complete details.

S4.

The Option Package price and monthly payment displayed is for illustration purposes, only. Prices and monthly payments may vary based on features included in package, financing terms and availability. Some Options are not available separately. Not all Options or Option Packages are available on all vehicles. See your local dealer for details.

S5. Estimated Net Price is the Total Manufacturer's Suggested Retail Price ("Total MSRP") minus any available offers and/or incentives. Incentives may vary. Excludes taxes, title, and registration fees. For authenticated AXZ Plan customers, the price displayed may represent Plan pricing. Not all AXZ Plan customers will qualify for the Plan pricing shown and not all offers or incentives are available to AXZ Plan customers.

S6.

The payment estimator will calculate a monthly payment based on the MSRP of the vehicle you have configured, including the dealer-installed accessories. For authenticated AXZ Plan customers, the price displayed may represent Plan pricing. Not all AXZ Plan customers will qualify for the Plan pricing shown. Actual monthly payment is based on a variety of factors, including differing financing or leasing terms, accessory prices and installation costs. Financing payment calculations are estimates only, and are based on amount of down payment, APR and term. Lease payment calculations are estimates only, and are based on an annual mileage calculation determined by your dealer. A charge is assessed for any mileage driven that exceeds this limit. Lessee is responsible for \$395 lease Disposition Fee in select states. Not all buyers will qualify for financing or a lease. Contact your local Ford or Lincoln Dealer for details.

S7.

While dealer inventory is generally updated on a daily basis, there are no guarantees that the inventory shown will be available at the dealership. Mid-model-year manufacturing changes, as well as dealer-added accessories on the actual vehicle may differ from the options and features listed. Vehicles that are identified as 'Exact Matches' may have a different price or different features not represented on the site. We make every effort to provide you with the most accurate, up-to-date information, however, only your local Ford dealer can provide you with information regarding actual vehicle availability.

S8.

Dealer Accessories are defined as items that do not appear on the factory window sticker that are installed by a Ford or Lincoln Dealers. Actual Prices for all accessories may vary and depend upon your dealer. Prices DO NOT include installation or painting, which may be required for particular items. Please check with your authorized dealer for complete pricing accuracy for all accessories and parts.

Genuine Ford Accessories will be warranted for whichever provides you the greatest benefit: 12 months or 12,000 miles (whichever occurs first) or the remainder of your Bumper-to-Bumper 3-year/36,000-mile New Vehicles Warranty. Contact your local Ford, Lincoln or Mercury dealer for details and a copy of the limited warranty.

Ford Licensed Accessories (FLA) are warranted by the accessories manufacturer's warranty. Contact your Ford, Lincoln or Mercury Dealer for details regarding the manufacturer's limited warranty and/or a copy of the FLA product limited warranty offered by the accessory manufacturer.

Most Ford Racing Performance Parts are sold with no warranty. Ford Racing Performance Parts are sold "As Is", "With All Faults", "As They Stand" and without any express warranty whatsoever, unless otherwise expressly designated herein. To determine which parts come with a warranty from the original manufacturer, or from Ford Racing, please contact the Ford Racing Techline at (800) FORD788.

S9.

The "Trade-In Value" of your vehicle is an estimate, only, and many factors that cannot be assessed without a physical inspection of the vehicle may affect actual value. For purposes of this website, we use the services of a third-party vendor to provide Trade-In Value calculations. While we believe this information is reliable, we are not responsible for and do not guarantee the accuracy



or reliability of the information. Please see your local Ford dealer for information regarding actual trade-in availability and value.

S10.

AXZ Plan pricing, including AXZ Plan option pricing, is exclusively for eligible Ford Motor Company employees, friends and family-members of eligible employees, and Ford Motor Company eligible partners. Restrictions apply. See your Ford or Lincoln dealer for complete details and qualifications. Ford Motor Company reserves the right to modify the terms of AXZ Plan pricing or availability at any time. Some dealers may also chose not to participate in plan pricing Contact your local dealer to determine final pricing.

S11.

EPA estimated city/highway mpg based on base engine/transmission configuration. Actual mileage will vary.

S12.

Towing - Properly equipped.

S13.

For Dealer Ordered vehicles, the vehicle has already been ordered by the dealer and is in the process of being manufactured by the factory. If you are interested in the vehicle marked "Dealer Ordered", contact the dealership for a delivery estimate.

S14. The "estimated selling price" is for estimation purposes only and the figures presented do not represent an offer that can be accepted by you. See your local dealer for vehicle availability and actual price. The Estimated Selling Price shown is the Base MSRP plus destination charges and total of options, but does not include service contracts, insurance or any outstanding prior credit balance. Does not include tax, title or registration fees. It also includes the acquisition fee. For Commercial Lease product, upfit amounts are included.

The "estimated capitalized cost" is for estimation purposes only and the figures presented do not represent an offer that can be accepted by you. See your local dealer for vehicle availability, actual price, and financing options. Estimated Capitalized Cost shown is the Base MSRP plus destination charges and total of options, but does not include service contracts, insurance or any outstanding prior credit balance. Does not include tax, title or registration fees. It also includes the acquisition fee. For Commercial Lease product, upfit amounts are included.

S15. The "amount financed" is for estimation purposes only and the figures presented do not represent an offer that can be accepted by you. See your local dealer for vehicle availability, actual price, and financing options. Estimated Amount Financed is the amount used to determine the Estimated Monthly Payment. It is equal to the Estimated Selling Price of the vehicle less Down Payment, Available Incentives and Net Trade-in Amount.

The "adjusted capitalized cost" is for estimation purposes only and the figures presented do not represent an offer that can be accepted by you. See your local dealer for vehicle availability, actual price, and financing options. Estimated Adjusted Capitalized Cost is the amount used to determine the Estimated Monthly Payment. It is equal to the Estimated Capitalized Cost less Down Payment, Available Incentives, and Net Trade-in Amount.

S16.

Total MSRP is Base MSRP plus options, destination and delivery charges. Excludes taxes, title, and registration fees.

S17.

Destination Charges are associated with getting the vehicle from the manufacturer to the dealership. Prices listed are MSRP and are based on information updated on this website from time to time.

S18. Acquisition Fee is a charge paid by the lessee to Ford Credit to help cover the cost of acquiring and servicing the account. Note2.

**For Manufacturer Specific Disclosures See Below**

1.

Starting MSRP excludes destination/delivery charge, taxes, title and registration. Optional equipment not included. Starting A, Z and X Plan price is for qualified, eligible customers and excludes document fee, destination/delivery charge, taxes, title and registration. Not all vehicles qualify for A, Z or X Plan. All Mustang Shelby GT350 and Shelby GT350R prices exclude gas guzzler tax.

2.

EPA-estimated city/hwy mpg. See fueleconomy.gov for fuel economy of other engine/transmission combinations. Actual mileage will vary. MPGe is the EPA equivalent measure of gasoline fuel efficiency for electric mode operation.

**DISCLOSURES ( )**

FF



# National Auto Fleet Group

A Division of Chevrolet of Watsonville  
 490 Auto Center Drive, Watsonville, CA 95076  
 (855) 289-6572 • (831) 480-8497 Fax  
 Fleet@NationalAutoFleetGroup.com

3/18/2020  
 7/7/2020 Re-Configured

Quote ID: **13215 R1**

Order Cut Off Date: **7/10/2020**

Mr Bob Scheidt  
 West Bay Sanitary District  
 500 Laurel St.  
 Menlo Park, California, 94025

Dear Bob Scheidt,

National Auto Fleet Group is pleased to quote the following vehicle(s) for your consideration.

**One (1) New/Unused (2020 Ford Super Duty F-350 DRW (F3G) XL 2WD Reg Cab 145" WB 60" CA, Western Truck Fab. Proposal 71295 108-94-43-CV Service Body)** and delivered to your specified location, each for

|   | One Unit (MSRP) | One Unit           | Total % Savings | Total Savings |
|---|-----------------|--------------------|-----------------|---------------|
| Contract Price  | \$49,865.00     | \$41,760.60        | 16.253 %        | \$8,104.40    |
| Western Truck Fab. Proposal 71295 108-94-43-CV Service Body | \$37,900.00     | \$37,900.00        |                 |               |
| Tax (9.2500 %)  |                 | \$7,368.61         |                 |               |
| Tire fee  |                 | \$10.50            |                 |               |
| Transportation  |                 | \$250.00           |                 |               |
| <b>Total</b>  |                 | <b>\$87,289.71</b> |                 |               |

- per the attached specifications.

This vehicle(s) is available under the **Sourcewell (Formerly Known as NJPA) Contract 120716-NAF**. Please reference this Contract number on all purchase orders to National Auto Fleet Group. Payment terms are Net 20 days after receipt of vehicle.

Thank you in advance for your consideration. Should you have any questions, please do not hesitate to call.

Sincerely,

Jesse Cooper  
 Account Manager  
 Email: Fleet@NationalAutoFleetGroup.com  
 Office: (855) 289-6572  
 Fax: (831) 480-8497

Quoting Department  
 Account Manager  
 Fleet@NationalAutoFleetGroup.com  
 (855) 289-6572



**GMC**

**In order to Finalize your Quote, please submit this purchase packet to your governing body for Purchase Order Approval. Once you issue a Purchase Order please send by:**

**Fax: (831) 480-8497**

**Mail: National Auto Fleet Group  
490 Auto Center Drive  
Watsonville, CA 95076**

**Email: Fleet@NationalAutoFleetGroup.com**

**We will then send a W-9 if you need one**

**Please contact our main office with any questions:  
1-855-289-6572**



## Vehicle Configuration Options

| ENGINE               |   |
|----------------------|---|
| Code                 | Description   |
| 99T                  | ENGINE: 6.7L 4V OHV POWER STROKE V8 TURBO DIESEL B20, -inc: Diesel Exhaust Fluid (DEF) tank, intelligent oil-life monitor and manual push-button engine-exhaust braking, 240 Amp Alternator, Dual 78-AH 750 CCA Batteries |
| TRANSMISSION         |   |
| Code                 | Description   |
| 44G                  | TRANSMISSION: TORQSHIFT 10-SPEED AUTOMATIC, -inc: selectable drive modes: normal, tow/haul, eco, deep sand/snow and slippery (STD)  |
| WHEELS               |   |
| Code                 | Description   |
| 64K                  | WHEELS: 17" ARGENT PAINTED STEEL, -inc: Hub covers/center ornaments not included (STD)  |
| TIRES                |   |
| Code                 | Description   |
| TD8                  | TIRES: LT245/75RX17E BSW PLUS A/S, -inc: Spare may not be the same as road tire (STD)   |
| PRIMARY PAINT        |   |
| Code                 | Description   |
| Z1                   | OXFORD WHITE  |
| PAINT SCHEME         |   |
| Code                 | Description   |
| ___                  | STANDARD PAINT  |
| SEAT TYPE            |   |
| Code                 | Description   |
| AS                   | MEDIUM EARTH GRAY, HD VINYL 40/20/40 SPLIT BENCH SEAT, -inc: center armrest, cupholder, storage and driver's side manual lumbar   |
| AXLE RATIO           |   |
| Code                 | Description   |
| X37                  | 3.73 AXLE RATIO, (STD)  |
| ADDITIONAL EQUIPMENT |   |
| Code                 | Description   |

|                       |  |
|-----------------------|--|
| 90L                   | POWER EQUIPMENT GROUP, -inc: Deletes passenger side lock cylinder, upgraded door-trim panel, Accessory Delay, Advanced Security Pack, SecuriLock Passive Anti-Theft System (PATS) and inclination/intrusion sensors, MyKey, owner controls feature, Power Locks, Remote Keyless Entry, Folding Trailer Tow Mirrors w/Power Heated Glass, manual telescoping, heated convex spotter mirror and integrated clearance lamps/turn signals, Power Front Side Windows, 1-touch up/down driver/passenger window |
| 52B                   | TRAILER BRAKE CONTROLLER, -inc: smart trailer tow connector, Verified to be compatible w/electronic actuated drum brakes only  |
| 76C                   | EXTERIOR BACKUP ALARM (PRE-INSTALLED), -inc: Custom accessory  |
| 942                   | DAYTIME RUNNING LAMPS (DRL), -inc: The non-controllable 942 Daytime Running Lamps (DRL) replace the standard Daytime Running Lamps (DRL) on/off cluster controllable   |
| 872                   | REAR VIEW CAMERA & PREP KIT, -inc: Pre-installed content includes cab wiring and frame wiring to the rear most cross member, Upfitters kit includes camera w/mounting bracket, 20' jumper wire and camera mounting/aiming instructions   |
| <b>OPTION PACKAGE</b> |  |
| <b>Code</b>           | <b>Description</b>   |
| 640A                  | ORDER CODE 640A  |

## 2020 Fleet/Non-Retail Ford Super Duty F-350 DRW XL 2WD Reg Cab 145" WB 60" CA

### WINDOW STICKER

2020 Ford Super Duty F-350 DRW XL 2WD Reg Cab 145" WB 60" CA

| CODE           | MODEL  | MSRP        |
|----------------|--|-------------|
| F3G            | 2020 Ford Super Duty F-350 DRW XL 2WD Reg Cab 145" WB 60" CA   | \$36,135.00 |
| <b>OPTIONS</b> |  |             |
| 99T            | ENGINE: 6.7L 4V OHV POWER STROKE V8 TURBO DIESEL B20, -inc: Diesel Exhaust Fluid (DEF) tank, intelligent oil-life monitor and manual push-button engine-exhaust braking, 240 Amp Alternator, Dual 78-AH 750 CCA Batteries  | \$10,250.00 |
| 44G            | TRANSMISSION: TORQSHIFT 10-SPEED AUTOMATIC, -inc: selectable drive modes: normal, tow/haul, eco, deep sand/snow and slippery (STD)   | \$0.00      |
| 64K            | WHEELS: 17" ARGENT PAINTED STEEL, -inc: Hub covers/center ornaments not included (STD)   | \$0.00      |
| TD8            | TIRES: LT245/75RX17E BSW PLUS A/S, -inc: Spare may not be the same as road tire (STD)  | \$0.00      |
| Z1             | OXFORD WHITE   | \$0.00      |
| —              | STANDARD PAINT   | \$0.00      |
| AS             | MEDIUM EARTH GRAY, HD VINYL 40/20/40 SPLIT BENCH SEAT, -inc: center armrest, cupholder, storage and driver's side manual lumbar  | \$0.00      |
| X37            | 3.73 AXLE RATIO, (STD)   | \$0.00      |
| 90L            | POWER EQUIPMENT GROUP, -inc: Deletes passenger side lock cylinder, upgraded door-trim panel, Accessory Delay, Advanced Security Pack, SecuriLock Passive Anti-Theft System (PATS) and inclination/intrusion sensors, MyKey, owner controls feature, Power Locks, Remote Keyless Entry, Folding Trailer Tow Mirrors w/Power Heated Glass, manual telescoping, heated convex spotter mirror and integrated clearance lamps/turn signals, Power Front Side Windows, 1-touch up/down driver/passenger window | \$915.00    |
| 52B            | TRAILER BRAKE CONTROLLER, -inc: smart trailer tow connector, Verified to be compatible w/electronic actuated drum brakes only  | \$270.00    |
| 76C            | EXTERIOR BACKUP ALARM (PRE-INSTALLED), -inc: Custom accessory  | \$140.00    |
| 942            | DAYTIME RUNNING LAMPS (DRL), -inc: The non-controllable 942 Daytime Running Lamps (DRL) replace the standard Daytime Running Lamps (DRL) on/off cluster controllable   | \$45.00     |
| 872            | REAR VIEW CAMERA & PREP KIT, -inc: Pre-installed content includes cab wiring and frame wiring to the rear most cross member, Upfitters kit includes camera w/mounting bracket, 20' jumper wire and camera mounting/aiming instructions   | \$415.00    |
| 640A           | ORDER CODE 640A  | \$0.00      |

Please note selected options override standard equipment



|                                 |                    |
|---------------------------------|--------------------|
| <b>SUBTOTAL</b>                 | <b>\$48,170.00</b> |
| Advert/ Adjustments             | \$0.00             |
| Manufacturer Destination Charge | \$1,695.00         |
| <b>TOTAL PRICE</b>              | <b>\$49,865.00</b> |

Est City: N/A MPG  
Est Highway: N/A MPG  
Est Highway Cruising Range: N/A mi

Any performance-related calculations are offered solely as guidelines. Actual unit performance will depend on your operating conditions.

## Standard Equipment

### MECHANICAL

|   |
|---|
| Engine: 6.2L 2-Valve SOHC EFI NA V8 (Flex-Fuel)   |
| Transmission: TorqShift 10-Speed Automatic -inc: selectable drive modes: normal, tow/haul, eco, deep sand/snow and slippery |
| 3.73 Axle Ratio   |
| GVWR: 14,000 lb Payload Package   |
| 50-State Emissions System   |
| Transmission w/Oil Cooler   |
| Rear-Wheel Drive  |
| 72-Amp/Hr 650CCA Maintenance-Free Battery w/Run Down Protection   |
| HD 200 Amp Alternator   |
| Towing Equipment -inc: Trailer Sway Control   |
| Trailer Wiring Harness  |
| 7940# Maximum Payload   |
| HD Shock Absorbers  |
| Front And Rear Anti-Roll Bars   |
| Firm Suspension   |
| Hydraulic Power-Assist Steering   |
| 40 Gal. Fuel Tank   |
| Single Stainless Steel Exhaust  |
| Dual Rear Wheels  |
| Front Suspension w/Coil Springs   |
| Leaf Rear Suspension w/Leaf Springs   |
| 4-Wheel Disc Brakes w/4-Wheel ABS, Front And Rear Vented Discs and Brake Assist   |
| Upfitter Switches   |

### EXTERIOR

|   |
|---|
| Wheels: 17" Argent Painted Steel -inc: Hub covers/center ornaments not included |
| Tires: LT245/75Rx17E BSW PLUS A/S -inc: Spare may not be the same as road tire  |
| Clearcoat Paint   |
| Black Front Bumper w/Black Rub Strip/Fascia Accent and 2 Tow Hooks              |
| Black Side Windows Trim and Black Front Windshield Trim                         |
| Black Door Handles  |
| Black Manual Side Mirrors w/Manual Folding                                      |
| Manual Extendable Trailer Style Mirrors   |
| Fixed Rear Window   |
| Light Tinted Glass  |

|  |
|--|
| Variable Intermittent Wipers   |
| Aluminum Panels  |
| Black Grille   |
| Front License Plate Bracket  |
| Autolamp Fully Automatic Aero-Composite Halogen Daytime Running Lights Preference Setting<br>Headlamps w/Delay-Off |
| Cab Clearance Lights   |

**ENTERTAINMENT**

|  |
|--|
| Radio: AM/FM Stereo w/MP3 Player -inc: 4 speakers  |
| Radio w/Seek-Scan  |
| Fixed Antenna  |
| SYNC Communications & Entertainment System -inc: enhanced voice recognition, 911 Assist, 4.2"<br>LCD center stack screen, AppLink, 1 smart-charging USB-C port and steering wheel audio controls |

**INTERIOR**

|   |
|---|
| 4-Way Driver Seat -inc: Manual Recline and Fore/Aft Movement  |
| 4-Way Passenger Seat -inc: Manual Recline and Fore/Aft Movement   |
| Manual Tilt/Telescoping Steering Column   |
| Gauges -inc: Speedometer, Odometer, Oil Pressure, Engine Coolant Temp, Tachometer, Transmission<br>Fluid Temp, Engine Hour Meter, Trip Odometer and Trip Computer |
| FordPass Connect 4G Mobile Hotspot Internet Access  |
| Manual Air Conditioning   |
| Illuminated Locking Glove Box   |
| Interior Trim -inc: Chrome Interior Accents   |
| Full Cloth Headliner  |
| Urethane Gear Shifter Material  |
| HD Vinyl 40/20/40 Split Bench Seat -inc: center armrest, cupholder, storage and driver's side manual<br>lumbar  |
| Day-Night Rearview Mirror   |
| Passenger Visor Vanity Mirror   |
| 2 12V DC Power Outlets  |
| Front Map Lights  |
| Fade-To-Off Interior Lighting   |
| Full Vinyl/Rubber Floor Covering  |
| Underhood Lights  |
| Smart Device Remote Engine Start  |
| Instrument Panel Covered Bin and Dashboard Storage  |
| Manual 1st Row Windows  |
| Systems Monitor   |



|   |
|---|
| Trip Computer                           |
| Outside Temp Gauge                      |
| Analog Display                          |
| Manual Adjustable Front Head Restraints |
| Air Filtration                          |

**SAFETY**

|  |
|--|
| Driveline Traction Control   |
| Side Impact Beams  |
| Dual Stage Driver And Passenger Seat-Mounted Side Airbags            |
| Low Tire Pressure Warning  |
| Dual Stage Driver And Passenger Front Airbags w/Passenger Off Switch |
| Safety Canopy System Curtain 1st Row Airbags                         |
| Outboard Front Lap And Shoulder Safety Belts -inc: Height Adjusters  |



MANUFACTURERS OF TRUCK BODIES AND EQUIPMENT

# Western Truck Fabrication, Inc.

1923 West Winton Avenue  
Hayward, CA 94545

Phone: 510-785-9994

Fax: 510-785-9986

www.westertruckfab.com

# Quotation

Date 3/19/2020

Quote # 71295

WTF Rep Mark

**Customer Name / Address**

NATIONAL AUTO FLEET GROUP  
ATT DAVID DAO  
1330 WEST MAIN STREET

**End User's Name** WEST BAY SANITA...**End User's Phone** 60**Contact Phone**

Vehicle Year 2020 FORD

Make / Model F350 REG CAB ...

W.B.

C.A. 60" DRW

**Dealer Contact** JESSE**Fuel Type** DIESEL

| Part #                 | Qty      | Description   | Tax |
|------------------------|----------|---|-----|
|                        |          | <b>TRUCK # 217</b>  |     |
| <b>WTSB1089438-C</b>   |          | <b>WESTERN TRUCK FAB MODEL 108-94-43-CV SERVICE BODY</b><br><b>***PADDLE LATCHES***</b><br><b>108" LONG</b><br><b>94" WIDE</b><br><b>***43" TALL**</b><br><b>49" FLOOR WIDTH</b><br><b>22-1/2" DEEP COMPARTMENTS</b><br><b>CLOSED TOP</b><br><b>VERTICAL DOOR CONFIGURATION</b><br><b>REAR STEP BUMPER</b><br><b>LED TAIL LIGHTS</b><br><b>UNDERSEALED AND PAINTED WHITE TO MATCH CAB</b> |     |
| <b>SB-HREC.</b>        |          | <b>FRAME MOUNTED CLASS IV RECEIVER HITCH WITH TWO 5/8" D RINGS</b><br><b>AND 7 WAY FLAT RV STYLE AND 4 PIN ROUND COMBO TRAILER PLUG</b>   |     |
| <b>SB-MLOCK-8-9.</b>   |          | <b>INTERNAL MASTER BAR LOCK SYSTEM WITH STAINLESS STEEL HANDLE</b><br><b>WITH PADLOCK PROVISION</b>   |     |
| <b>SB-LT-STP.</b>      | <b>1</b> | <b>BUYERS LED STRIP LIGHTING FOR SIDES AND TOP OF EACH</b><br><b>COMPARTMENT ON SINGLE SWITCH IN DASH</b>   |     |
| <b>EC-WRKLTPOLE...</b> |          | <b>1 EACH LED 6" X 5" WORK LIGHT ON HEIGHT ADJUSTABLE POLE</b><br><b>MOUNTED DRIVER SIDE REAR</b>   |     |

PLEASE REVIEW AND READ QUOTE CAREFULLY.  
 SPECIAL ORDERS ARE NON RETURNABLE AND NON REFUNDABLE.  
 ALL RETURNED PARTS ARE SUBJECT TO A 25% RESTOCKING FEE.  
 CREDIT CARD PAYMENTS OVER \$1,000 ARE SUBJECT TO A 3% PROCESSING FEE.  
 UPON ACCEPTANCE OF THIS QUOTE CIRCLE OPTIONS DESIRED, SIGN & FAX BACK TO 510.785.9986  
 THIS QUOTE IS GOOD FOR 30 DAYS FROM THE DATE OF CREATION.

Accepted By: \_\_\_\_\_ Date: \_\_\_\_\_

P.O #: \_\_\_\_\_ Chassis ETA: \_\_\_\_\_

VIN #: \_\_\_\_\_

**THANK YOU FOR THE  
OPPORTUNITY  
TO QUOTE THIS JOB**

Page 1

**\*\*NOT RESPONSIBLE FOR LOST OR MISSING EQUIPMENT\*\***





MANUFACTURERS OF TRUCK BODIES AND EQUIPMENT

# Western Truck Fabrication, Inc.

1923 West Winton Avenue  
Hayward, CA 94545

Phone: 510-785-9994

Fax: 510-785-9986

www.westerntruckfab.com

# Quotation

Date 3/19/2020

Quote # 71295

WTF Rep Mark

### Customer Name / Address

NATIONAL AUTO FLEET GROUP  
ATT DAVID DAO  
1330 WEST MAIN STREET

End User's Name WEST BAY SANITA...

End User's Phone 60

Contact Phone

Vehicle Year 2020 FORD

Make / Model F350 REG CAB ...

W.B.

C.A. 60" DRW

Dealer Contact JESSE

Fuel Type DIESEL

| Part #       | Qty | Description   | Tax |
|--------------|-----|---|-----|
| MATERIALS SB |     | <b>1 EACH 6 X 5 LED WORK LIGHT MOUNTED ON PASSENGER SIDE REAR END PANEL WIRED TO SAME SWITCH AS POLE LIGHT<br/>***LIGHT WILL SWIVEL***<br/>***LIGHT NOT TO INTERFERE WITH CRANE ROTATION***</b>   |     |
| SB-SL9.      | 1   | <b>SPRAY IN SPEEDLINER BED LINER FOR ENTIRE CARGO AREA</b>  |     |
| MATERIALS SB | 1   | <b>LIFTMOORE MODEL 2700AR-14<br/>Mounted right rear top of body<br/>8,100 Ft.-Lbs. Moment Rating<br/>Maximum Capacity 2,700 Lbs. at 3 Ft. Load radius<br/>Planetary Gear Winch with 2.4 HP Permanent Magnet Motor<br/>On / Off 12 Volt electric control system<br/>Wireless remote control with back-upPendant Control 18 Ft., E-Stop &amp; audible signal function<br/>Galvanized Aircraft Cable 1/4" x 62 Ft. (7,000 Lbs. Breaking Strength)<br/>Travel Block w/ swivel hook, for easy two part line hook up<br/>Power Rotation - Unlimited<br/>Boom Elevation - Full Power (-5 Deg. To 75 Deg.)<br/>Boom Extension - Manual 6 Ft. - 14 Ft. in two sections<br/>Counter balance (holding) valve integrated in cylinder<br/>Overload Protection System<br/>ATB System<br/>Meets requirements of 29 CFR 1910.180, ANSI B30.5, SAE J1063</b> |     |
| MATERIALS SB | 1   | <b>CRANE REINFORCEMENT IN PASSENGER REAR COMPARTMENT</b>  |     |
| MATERIALS SB | 1   | <b>SLIP IN OUTRIGGER WITH TUBE UNDER BODY</b>   |     |

PLEASE REVIEW AND READ QUOTE CAREFULLY.  
SPECIAL ORDERS ARE NON RETURNABLE AND NON REFUNDABLE.  
ALL RETURNED PARTS ARE SUBJECT TO A 25% RESTOCKING FEE.  
CREDIT CARD PAYMENTS OVER \$1,000 ARE SUBJECT TO A 3% PROCESSING FEE.  
UPON ACCEPTANCE OF THIS QUOTE CIRCLE OPTIONS DESIRED, SIGN & FAX BACK TO 510.785.9986  
THIS QUOTE IS GOOD FOR 30 DAYS FROM THE DATE OF CREATION.

Accepted By: \_\_\_\_\_ Date: \_\_\_\_\_

P.O #: \_\_\_\_\_ Chassis ETA: \_\_\_\_\_

VIN #: \_\_\_\_\_

**THANK YOU FOR THE  
OPPORTUNITY  
TO QUOTE THIS JOB**

Page 2

**\*\*NOT RESPONSIBLE FOR LOST OR MISSING EQUIPMENT\*\***



MANUFACTURERS OF  
TRUCK BODIES AND  
EQUIPMENT

# Western Truck Fabrication, Inc.

1923 West Winton Avenue  
Hayward, CA 94545

Phone: 510-785-9994

Fax: 510-785-9986

www.westerntruckfab.com

# Quotation

Date 3/19/2020

Quote # 71295

WTF Rep Mark

**Customer Name / Address**

NATIONAL AUTO FLEET GROUP  
ATT DAVID DAO  
1330 WEST MAIN STREET

**End User's Name** WEST BAY SANITA...

**End User's Phone** 60

**Contact Phone**

Vehicle Year 2020 FORD

Make / Model F350 REG CAB ...

W.B.

C.A. 60" DRW

**Dealer Contact** JESSE

**Fuel Type** DIESEL

| Part #        | Qty | Description   | Tax |
|---------------|-----|---|-----|
| MATERIALS SB  | 1   | AUXILIARY BATTERY AND ISOLATOR FOR CRANE OPERATION WITH BATTERY IN PASSENGER REAR COMPARTMENT                               |     |
| MATERIALS SB  | 1   | SUPER SPRINGS FOR PASSENGER REAR TO BRING TRUCK TO LEVEL  |     |
| MATERIALS SB  | 1   | VANNER 3000 WATT INVERTER WITH AUXILIARY BATTERY AND ISOLATOR IN PASSENGER FRONT COMPARTMENT MOUNTED AT TOP ON FIXED SHELF. |     |
| MATERIALS SB  | 1   | 2 EACH GFI RECEPTACLES WIRED TO THE INVERTER MOUNTED 1 EACH SIDE AT REAR  |     |
| WEIGHT CERT   | 1   | WEIGHT CERTIFICATION  |     |
| MATERIAL MISC | 1   | DELVIER UNIT TO WEST BAY SANITATION MENLO PARK CA, CONTACT BOB SCHEIDT 650-321-0397   |     |
|               |     | END USER WEST VALLEY SANITATION<br>BOB SCHEIDT<br>650-321-0397<br>650-477-6416 CELL   |     |

PLEASE REVIEW AND READ QUOTE CAREFULLY.  
SPECIAL ORDERS ARE NON RETURNABLE AND NON REFUNDABLE.  
ALL RETURNED PARTS ARE SUBJECT TO A 25% RESTOCKING FEE.  
CREDIT CARD PAYMENTS OVER \$1,000 ARE SUBJECT TO A 3% PROCESSING FEE.  
UPON ACCEPTANCE OF THIS QUOTE CIRCLE OPTIONS DESIRED, SIGN & FAX BACK TO 510.785.9986  
THIS QUOTE IS GOOD FOR 30 DAYS FROM THE DATE OF CREATION.

Accepted By: \_\_\_\_\_ Date: \_\_\_\_\_

P.O #: \_\_\_\_\_ Chassis ETA: \_\_\_\_\_

VIN #: \_\_\_\_\_

THANK YOU FOR THE  
OPPORTUNITY  
TO QUOTE THIS JOB

Subtotal **\$37900.00**

Sales Tax (9.75%) **\$0.00**

Total **\$37,900.00**

**\*\*NOT RESPONSIBLE FOR LOST OR MISSING EQUIPMENT\*\***





## WEST BAY SANITARY DISTRICT AGENDA ITEM 10

**To:** *Board of Directors*

**From:** *Sergio Ramirez, District Manager*

**Subject:** *Consideration to Approve Amendment 3 to the Consultant Agreement for Recycled Water Project Management Phase B Dated March 14, 2017*

---

### Background

The West Bay Sanitary District Recycled Water Project – Sharon Heights (also known as the “Project”) is the planned construction of a water supply project that would deliver up to 152 to 200 acre-feet per year (AFY) of recycled water produced by the District at a Recycled Water Treatment facility located on property owned by Sharon Heights Golf and Country Club (SHGCC).

On March 22, 2017 the District Board approved a Professional Consultant Agreement for Phase “B” Project Management Services for the Recycled Water Project – Sharon Heights for a not-to-exceed amount of \$778,500.00 with RMC Water and Environment.

During Phase B of the Project Management, Woodard & Curran (originally RMC) incurred some additional costs due to the extended negotiations and Design Build Team selection process. The Board approved Amendment #1 on October 10, 2018 for a total cost impact of \$66,000 and Amendment #2 on May 13, 2020 for \$65,842.

Due to an extension of the project construction schedule and the need for training and development of materials for District staff to properly oversee the distribution and application of recycled water, an additional \$10,000 is requested as Amendment #3 to the agreement.

The project was not entirely operational on March 31, 2020 due to the lack of a permit from the State to operate which was in turn due to the Ultra Violet disinfection system not having a bioassay test performed and passed. As a result, over the next three months, until the District received permission to operate on July 24, 2020, Woodard & Curran expended many additional hours working with the Division of Drinking Water and the Regional Water Quality Control Board to help the District secure a permit to operate.

---



## Analysis

The amendment to the Project Management agreement includes two changes:

- 1) Add budget to the Task 6 - Regulatory and Permitting, and Partner Agencies Liaison, for additional effort required to support Title 22 Permitting through the State of California Division of Drinking Water and the Regional Water Quality Control Board.
- 2) The net fee amendment is \$10,000. The new total amount is Not-To-Exceed \$706,178.

The Amendment for these Woodard & Curran contract modifications is attached.

## Fiscal Impact

The costs for the Project Management consulting services are considered 'soft costs' of the recycled water project and are reimbursable through the SRF loan process which is paid by SHGCC. District Capital Asset funds will bridge the expense until reimbursement is received by the State.

## Recommendation

The District Manager recommends the District Board Authorize the District Manager to Execute Amendment No.3 for an additional \$10,000.00 to the Professional Consultant Agreement for Phase "B" Project Management Services for the Recycled Water Project– Sharon Heights.

Attachments:

Amendment No. 3

**AMENDMENT #3 TO WOODARD & CURRAN AGREEMENT FOR  
PROJECT MANAGEMENT FOR THE WEST BAY SANITARY DISTRICT RECYCLED WATER PROJECT –  
SHARON HEIGHTS**

WEST BAY SANITARY DISTRICT (District) has engaged Woodard & Curran, Inc. (originally RMC Water & Environment), to provide Project Management Services for design and construction of the Recycled Water Project – Sharon Heights. The purpose of this agreement is to amend the original Agreement with the District dated March 24, 2017 and to modify the scope of services as allowed under contract Section XIII.

This amendment dated this \_\_\_\_ day of \_\_\_\_\_ 2020 is the third (3<sup>rd</sup>) amendment to the Agreement. This amendment will accomplish the following:

- Add budget to the Task 6 - Regulatory and Permitting, and Partner Agencies Liaison, for additional effort required to support Title 22 Permitting through the State of California Division of Drinking Water and the Regional Water Quality Control Board.

The net fee amendment is **\$10,000**. The new total amount is Not-To-Exceed **\$706,178**. This amendment is subject to the same provisions as the original agreement and is made part of the Agreement.

IN WITNESS WHEREOF, the parties have executed this Agreement on the dates indicated below.

Dated \_\_\_\_\_, 2020

Dated \_\_\_\_\_, 2020

Woodard & Curran, Inc.

WEST BAY SANITARY DISTRICT

\_\_\_\_\_  
Signature

\_\_\_\_\_  
Signature

David L. Richardson

Sergio Ramirez

Printed Name

Printed Name

Senior Vice President

District Manager

Title

Title

APPROVED AS TO FORM:

\_\_\_\_\_

Tony Condotti, District Counsel

**AMENDMENT #3 TO WOODARD & CURRAN AGREEMENT FOR  
PROJECT MANAGEMENT FOR THE WEST BAY SANITARY DISTRICT RECYCLED WATER PROJECT –  
SHARON HEIGHTS**

**SCOPE OF SERVICES**

The amended Scope of Services detailed below are made relative to the original Agreement for Project Management Services dated March 24, 2017.

**CHANGES TO SCOPE OF SERVICES**

**Task 6 – Regulatory and Permitting and Partner Agency Liaison**

Additional level of effort has been required to complete Title 22 permitting through the California Division of Drinking Water (DDW) and the Regional Water Quality Control Board (Regional Board). The initial UV Bioassay testing, completed by the DB Team, demonstrated that one of the two UV reactors at the new treatment plant was not performing as expected. In support of the effort to get the plant permitted, Woodard & Curran stepped in to facilitate discussions and coordinate with DDW and the Regional Board on alternative permitting approaches. Work included conference calls, direct contacts with DDW and Regional Board staff, review of preliminary permitting materials, updates to Title 22 Reports in response to DDW comments and bioassay results, and proactive tracking of the permitting process. The final Notice of Applicability was received on July 24, 2020.

**CHANGES TO CONTRACT FEE:**

Changes to the Agreement fee are as follows:

| Task  | Agreement Fee<br>(Phase B)<br>As Amended by<br>Amendment #2 | Change<br>in Fee | Amended<br>Fee<br>(Amendment #3) <sup>a</sup> |
|---|---|------------------|---|
| 1 – Acquisition of Design Build Team                              | \$115,498   | \$0              | \$115,498                                     |
| 2 – Planning and Coordination                                     | \$0   | \$0              | \$0   |
| 3 – Predesign, Design Reviews and Overall Design-Build Management | \$76,274  | \$0              | \$76,274                                      |
| 4 – Services for Construction Administration                      | \$313,652   | \$0              | \$313,652                                     |
| 5 – Financing Coordination  | \$51,328  | \$0              | \$51,328                                      |
| 6 – Regulatory and Permitting and Partner Agency Liaison          | \$28,536  | \$10,000         | \$38,536                                      |
| 7 – Public Outreach   | \$10,000  | \$0              | \$10,000                                      |
| 8 – Funding Acquisition   | \$0   | \$0              | \$0   |
| 9 – Project Management  | \$83,446  | \$0              | \$83,446                                      |
| 10 – Recycled Water Training                                      | \$17,444  | \$0              | \$17,444                                      |
| <b>TOTAL</b>  | <b>\$696,178</b>  | <b>\$10,000</b>  | <b>\$706,178</b>                              |

Notes:

- a. Individual task fees may be reallocated with District approval without change to total fee.



## WEST BAY SANITARY DISTRICT AGENDA ITEM 11

**To:** *Board of Directors*

**From:** *Sergio Ramirez, District Manager*

**Subject:** *Review and Consideration to Approve the Conflict of Interest Code and General Rules of Office for the District Board*

---

### Background

The Fair Political Practices Commission under Title 2 California Administrative Code, Section 18730, requires the District maintain a Conflict of Interest Code as a statement of policies and guiding principles. This Code of Ethics and Conduct is meant to outline some of the legal and ethical obligations of Board Members.

Each local agency is required to review its Conflict of Interest Code biennially to determine if it is accurate or, alternatively, if it must be amended. Upon review or amendment, the District must submit a completed notice to the Office of the Assessor-County Clerk-Recorder, due September 1, 2020.

As a more comprehensive guideline the Board also maintains a code of ethics within the General Rules of Office for the District Board which is also subject to periodic review, and revision if needed. Efficiency and opportunity provide cause to review the Rules of Office simultaneously with the Conflict of Interest Code.

On March 14, 2018, the Board approved changes to the procedures for swearing in of Board Members and Appointment of Officers which have been incorporated into the General Board Rules for the Boards review and approval as a complete document.

### Analysis

The GENERAL RULES OF OFFICE include a section for Conflicts of Interest and Statement of Economic Interest. The Conflicts of Interest section outlines prohibitions designed to restrain a public Board Member from participating in or attempting to influence those governmental decisions or actions in which he or she has a "financial interest" which could be materially affected by the decision.

Statements of Economic Interest or better known as Form 700's are required to be filed annually and at the beginning of term of office, and require Members to disclose all investments, business positions, sources of income, and interests in real property which could be materially affected by the decisions made by their commission.

---

Attached for review are:

- Resolution 1595 (2006) – the existing Conflict of Interest Code
- The current General Rules of Office for the District Board
- The current list of “Designated Filers” for which the District has Form 700’s
- On March 14, 2018, the Board approved changes to the procedures for swearing in of Board Members and Appointment of Officers which have been incorporated into the General Board of Office for the Board’s review and approval as a complete document.

Fiscal Impact

N/A

Recommendation

The District Manager recommends the Board review and approve the General Rules of Office including the revisions, and review the Conflict of Interest Code and determine whether any amendments are needed:

1. If amendments are needed, direct the District Manager to incorporate those amendments in the document(s) and bring to the Board for final approval at a future Board meeting and file notice to the Office of the Assessor-County Clerk-Recorder that the code is currently under review by the Board.
2. If no amendments are needed, approve and direct the District Manager to file the required notice to the Office of the Assessor-County Clerk-Recorder that “No Amendment is Required” (this designation refers to the Conflict of Interest Code rather than the General Rules of Office).

**RESOLUTION NO. 1595 (2006)**

**IN THE DISTRICT BOARD OF THE WEST BAY SANITARY DISTRICT  
COUNTY OF SAN MATEO, STATE OF CALIFORNIA**

\*\*\*\*\*

**A Resolution Restating a Conflict of Interest Code  
For the West Bay Sanitary District By Adopting  
Fair Political Practices Commission Standard Code**

\*\*\*\*\*

**BE IT RESOLVED**, by the Board of Directors of the West Bay Sanitary District, San Mateo County, California, as follows:

1. That the "Code" entitled "Conflict of Interest Code of the West Bay Sanitary District", being the standard conflict of interest code promulgated by the Fair Political Practices Commission under 2 California Administrative Code, Section 18730, a copy of which Code is attached hereto and by reference incorporated herein, be, and is hereby, approved and adopted for the District, subject to the approval thereof by the Board of Supervisors of the County of San Mateo.

2. That the Secretary of the District be, and is hereby, authorized and instructed to submit a copy of such Code to the Board of Supervisors of the County of San Mateo and to request said Board of Supervisors to approve said Code in accordance with Government Code Section 87303.

3. That pursuant to Section 4(B) of the Standard Code, designated Officials and Employees shall file statements of economic interests with the District which shall retain the originals. The District Manager shall be designated as the filing officer.

\*\*\*\*\*

I hereby certify that the foregoing is a full, true and correct copy of a resolution duly and regularly passed and adopted by the Board of Directors of the West Bay Sanitary District, San Mateo County, California, at a meeting thereof held on the 24th day of July, 2006, by the following vote:

|                 |   |
|-----------------|---|
| <b>Ayes:</b>    | Shepherd, Walker, Knight, Lomax, Harrison |
| <b>Noes:</b>    | None                                      |
| <b>Abstain:</b> | None                                      |
| <b>Absent:</b>  | None                                      |

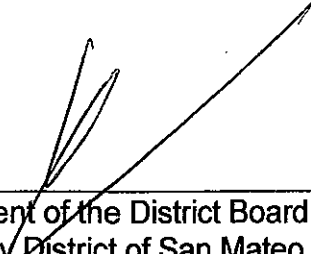

---

President of the District Board of the West Bay  
Sanitary District of San Mateo County, State of  
California

Attest:

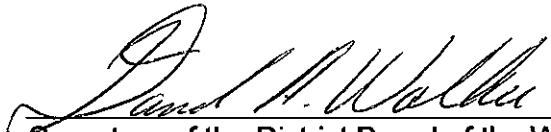

---

Secretary of the District Board of the West Bay  
Sanitary District of San Mateo County, State of  
California



## WEST BAY SANITARY DISTRICT CONFLICT OF INTEREST CODE

The purposes of this Conflict of Interest Code are to provide for the disclosure of investments, real property, income and business positions of designated WEST BAY SANITARY DISTRICT officials and employees that may be materially affected by their official actions and to provide for the disqualification of designated officials and employees from participation in WEST BAY SANITARY DISTRICT decisions in which they may have a financial interest.

### Background

The political reform Act of 1974 (Government Code Sections 81000 et seq.) requires state and local government agencies to adopt and promulgate conflict of interest codes. The Fair Political Practices Commission has adopted a regulation, California Code of Regulations Section 18730, which contains the terms of a standard conflict of interest code. This regulation and any amendments thereto may be incorporated by reference by local agencies and, together with the designation of employees and disclosure categories, meets the requirements of the Political Reform Act.

### Adoption of Conflict of Interest Code

The terms of Title 2 California Code of Regulations Section 18730 are hereby incorporated by reference and, along with the attached Appendix in which officials and employees are designated and disclosure categories are set forth, constitute the Conflict of Interest Code of the WEST BAY SANITARY DISTRICT.

Pursuant to the Political Reform Act and its regulations, all designated employees shall file statements of economic interests with the District Manager who shall be the filing officer. The San Mateo County Board of Supervisors shall be the code reviewing body.

Subsequent amendments to Title 2 California Code of Regulations Section 18730 duly adopted by the Fair Political Practices Commission, after public notice and hearings, are also incorporated by reference unless the WEST BAY SANITARY DISTRICT, within 90 days after the date on which an amendment to Section 18730 becomes effective, adopts a resolution providing that the amendment is not to be incorporated into this Code.

WEST BAY SANITARY DISTRICT  
Conflict Of Interest Code

List of Designated WEST BAY SANITARY DISTRICT Officials and Employees  
Description of Financial Disclosure Categories

Each person holding any position listed below must file statements disclosing the kinds of financial interest shown for the designated employee's position. Statements must be filed at the times and on the forms prescribed by law. Failure to file statements on time may result in penalties including, but not limited to, late fines.

| <u>Designated Employees</u> | <u>Disclosure Category</u> |
|-----------------------------|----------------------------|
| Director                    | 1,2,3,4                    |
| District Manger             | 1,2,3,4                    |
| Legal Counsel               | 1,2,3,4                    |
| District Engineer           | 1,2,3,4                    |
| Consultants*                | 1,2,3,4                    |

\* Each agency or department shall review the duties and authority of all consultants retained by the agency. Those consultants who, within the meaning of 2 California Code of Regulations 18700 (a) (2) are required to file statements of economic interests, shall do so. During each calendar year, the WEST BAY SANITARY DISTRICT shall maintain a list of such consultants for public inspection in the same manner and location as this Conflict of Interest Code. Nothing herein excuses any consultant from any other provision of the Conflict of Interest Code, specifically those dealing with disqualification.

Disclosure Categories

Category 1. A designated official or employee assigned to Category 1 is required to disclose direct or indirect investments in any business entity that may foreseeable be affected materially by any decision made or participated in by the designated official or employee by virtue of his or her position.

Category 2. A designated official or employee assigned to Category 2 is required to disclose interests in any real property that may foreseeably be affected materially by any decision made or participated in by the designated official or employee by virtue of his or her position.

Category 3. A designated official or employee assigned to Category 2 is required to disclose any source of income that may foreseeably be affected materially by any decision made or participated in by the designated official or employee by virtue of his or her position.

Category 4. A designated official or employee assigned to Category 2 is required to disclose any business entity in which the designated official or employee is a director, officer, partner, trustee, employee or holds any position of management that may foreseeably be affected materially by any decision made or participated in by the designated official or employee by virtue of his or her position.

Forms to be filed with: District Manager  
West Bay Sanitary District  
500 Laurel Street  
Menlo Park, CA 94025

**WEST BAY SANITARY DISTRICT  
GENERAL RULES OF OFFICE  
FOR THE  
DISTRICT BOARD**

**Revision Date: 2/13/2013**

**Reviewed Date: 3/28/2018, 8/12/20**

**GENERAL RULES OF OFFICE FOR THE DISTRICT BOARD**

**1. Code of Ethics and Conduct**

**A. Purpose.** The Board of Directors of the West Bay Sanitary District has adopted the following set of principles of ethics and conduct as an expression of policy to guide the Board in its decision-making. As a statement of policies and guiding principles, this Code of Ethics and Conduct is meant to outline some of the legal and ethical obligations of Board Members, but shall not supersede existing laws and regulations.

**B. Board Member Duties and Obligations.** Each Board Member has the following duties:

1. To represent and work for the common good of the District and its citizens.
2. To provide fair and equal treatment for all persons and matters coming before the Board.
3. To faithfully perform all duties of their elected office, including:
  - a) understanding the roles and responsibilities of the Board position; and
  - b) becoming thoroughly knowledgeable about items of business before voting or developing a conclusion or recommendation; and
  - c) attending regular meetings.
4. To listen courteously and attentively to all public discussions and avoid interrupting other speakers, except as may be permitted by established Rules of Order.
5. To refrain from abusive conduct, personal charges or verbal attacks upon the character, motives, ethics or morals of other members of the District Board, District Employees, or members of the public.
6. All Board meeting shall be properly noticed and agendized in accordance with the Brown Act, and individual Board Members shall conduct themselves in accordance with the requirements thereof.

7. Confidential information shall not be disclosed by individual Board Members without the prior consent of a majority of the Board. Confidential information includes, but is not limited to the following: (1) documents which are exempted from disclosure under the Public Record Act (Govt. Code section 6250, et seq.); (2) information received in closed session; and (3) communications from legal counsel which are protected by attorney-client and attorney work-product privileges.
8. To scrupulously adhere to all pertinent laws and regulations governing conflicts of interest.
9. To refrain from accepting gifts, favors, or promises of future benefits which might compromise or tend to impair independent judgment or action.

### **C. Disciplinary Action**

The Board of Directors may exercise any and all available legal remedies if it determines that a Board Member has violated any provision of state law governing conflicts of interest or self-interested contracts including, if applicable, referring the matter to appropriate prosecutorial authorities. The Board of Directors may further exercise all available legal remedies including, but not limited to, seeking injunctive relief, to prevent any violation of this Code respecting confidentiality and privilege. And the Board may publicly censure or reprimand any Board Member who violates any provision of this Code. Ultimate responsibility for complying with the Code rests with the individual Board Members.

### **2. Conflicts of Interest**

The following is a brief summary of relevant portions of state law affecting service on the Board of Directors:

- A. **Interests in Contracts:** Members of the District Board and other public officers may not make any contract with the District in which they have a financial interest. Such contracts are void. (Government Code 1090, et seq.)
- B. **Discounted or Free Transportation Passes:** Office holders in California are strictly prohibited from accepting free passes or discounts from transportation companies. Violation of this prohibition is punishable by forfeiture of office. (California State Constitution)
- C. **The Political Reform Act:** The Political Reform Act (Government Code 81000, et seq.) forbids a public Board Member from participating in or attempting to influence those governmental decisions or actions in which he or she has a “financial interest” which could be materially affected by the decision. The Act defines the kinds of interests, (which includes interests owned by spouses, dependent children and agents, and certain businesses and trusts) which might cause a conflict and requires public Board Members to disqualify themselves from decisions which could affect those interests.

The Fair Political Practices Commission (FPPC) enforces the Political Reform Act.

### **3. Statement of Economic Interest**

As established in Government Code 87200, Board Members must file Statements of Economic Interest upon assumption of office, on an annual basis, and when leaving office. The proper forms are supplied by the District. Members must disclose all investments, business positions, sources of income, and interests in real property which could be materially affected by the decisions made by their commission. The completed statements are kept on file by the District and are available for public inspection. Since the law permits the Fair Political Practices Commission to impose a penalty for failure to disclose in a timely manner, elected Board Members should be certain the statements are complete and filed on time.

### **4. Relations with District Staff**

The District staff works under the direction of the District Manager. While the Board as a whole may direct the District Manager, individual Board Members shall not provide such direction or to become involved in the administrative or operational concerns of the District departments. However, the staff will be happy to answer questions and provide whatever assistance they can when authorized to do so by the District Manager.

It is expected that a mutually respectful and professional relationship will be maintained between the staff personnel and the Board Members. In the event that a conflict does arise, the problem should be brought to the attention of the District Manager, and if it is not satisfactorily resolved, brought to the attention of the President of the Board.

### **5. Officers and Committees**

It shall be the policy of the District Board to elect officers of the Board during the month of December depending on ranges of Board Member terms. A Board Member must have served at least one year in office to qualify for service as an Officer.

**A. Board Officers:** The Board shall hold annual elections at its last December meeting for President and Secretary. The terms of office for President and Secretary shall be one year, commencing on the first day of January and end on the thirty-first day of December.

**B. President Duties:** The President shall serve as the presiding officer and chair all meetings of the Board, shall collaborate with the District Manager to establish the agenda for regular and special meeting, shall sign all documents on behalf of the Board and District that may be required, and shall have the same right and responsibilities as other Directors to participate in and vote at board meetings. The President shall appoint a Board Member to serve as Treasurer, and shall have the authority to establish and specify the duties and responsibilities of all advisory committees, and appoint Directors who will serve thereon for the upcoming year provided, however, that the Board, by majority vote, may modify such committees or appointments. All committees appointed by the President shall serve in an advisory capacity only, and shall report directly to the Board of Directors.

**C. Secretary Duties:** The Secretary shall countersign all documents on behalf of the Board and District that may be required, and shall serve as the President pro tem in case of the absence or inability of the President to act. In case of the absence or

inability of the Secretary to act on behalf of the District, or in event that the Secretary is serving as President pro tem, the Board shall choose a Secretary pro tem to act on his or her behalf.

**D. Treasurer Duties:** The Treasurer shall be appointed by the President, and shall participate in discussions regarding District investments and audits. The Treasurer shall be bonded and, in event of the unavailability of the President or Secretary, may sign official documents on behalf of the District. The Treasurer may provide reports on financial matters in regular or special Board meetings.

## **6. Orientation for New Members**

Shortly after election, a general orientation will be provided by the District Manager and staff. This orientation is intended to acquaint newly elected Board Members with the District goals, the responsibilities of the appointment, and current issues before the body and meeting schedules.

## **7. Resignation**

If a Board member resigns from office before the end of his or her term, the member should write a letter announcing the resignation and specifying the effective date thereof, and deliver it to the District Manager, who will forward copies to the District Board.

## **8. Benefits/Insurance/Immunity**

Board Members are covered by Workers' Compensation and, in the event of an accident while serving in an official capacity, the member will be required to file an accident report. Members are also covered under the District's general liability insurance policy for actions taken in the course and scope of their duties. The Tort Claims Act also limits individual liability and in most situations immunizes Board Members from legal liability for actions taken in exercising discretion, or in exercising duties of their positions.

## **9. Travel and Expense Reimbursement**

**A. PURPOSE.** The purpose of this policy is to provide guidance to Board Members and other District officials on the use and expenditure of District resources and to establish a written policy for reimbursement of necessary expenses by Board Members. This section shall also apply to Regular District employees for the purposes of Travel and Expense Reimbursement.

**B.** In addition:

1. This policy satisfies the requirements of Government Code sections 53232.2 and 53233.3.
2. This policy supplements the definition of actual and necessary expenses for purposes of state laws relating to permissible uses of public resources.
3. This policy also supplements the definition of necessary and reasonable expenses for purposes of federal and state income tax laws.



4. This policy also applies to any charges made to a District credit card, cash advances or other line of credit.

**C. AUTHORIZED EXPENSES.** District funds, equipment, supplies (including letterhead), titles, and staff time must only be used for authorized District business. Expenses incurred in connection with the following types of activities generally constitute authorized expenses:

1. Communicating with representatives of local, regional, state and national government on District business or adopted policy positions;
2. Attending educational seminars designed to improve officials' skill and information levels;
3. Participating in regional, state and national organizations whose activities affect the District's interests;
4. Recognizing service to the District (for example, thanking a longtime employee with a retirement gift or celebration of nominal value and cost);
5. Attending District events; and
6. All other expenditures require prior approval by the Board of Directors.

**D.** Examples of personal expenses that the District will not reimburse include, but are not limited to:

1. The personal portion of any trip;
2. Political or charitable contributions or events;
3. Family expenses, including partner's expenses when accompanying official on agency-related business, as well as children- or pet-related expenses;
4. Entertainment expenses, including theater, movies (either in-room or at the theater), sporting events (including gym, massage and/or golf-related expenses), or other cultural events; and
5. Non-mileage personal automobile expenses, including repairs, traffic citations, insurance or gasoline; and

**E.** Any questions regarding the propriety of a particular type of expense should be resolved before the expense is incurred.

**F.** To conserve District resources and keep expenses within community standards for public officials, expenditures should adhere to the following guidelines. In the event that expenses are incurred which exceed these guidelines, the cost borne or reimbursed by the District will be limited to the costs that fall within the guidelines, unless special circumstances are shown and a majority of the Board of Directors approves reimbursement of the expense in advance of the event or occasion resulting in the expense.

**G.** Whenever possible, registration and travel arrangements shall be coordinated through the District Manager's Office.

**H. Transportation.** The most economical mode and class of transportation reasonably consistent with scheduling needs and cargo space requirements must be used, using the most direct and time-efficient route. Government and group rates must be used

when available. Automobile mileage is reimbursed at Internal Revenue Service rates presently in effect (see <http://www.irs.gov/>). Bridge and road tolls are reimbursable.

- I. Lodging.** Lodging expenses will be reimbursed or paid for when travel on official District business reasonably requires an overnight stay.
  1. Conferences/Meetings. If such lodging is in connection with a conference, lodging expenses must not exceed the group rate published by the conference sponsor for the meeting in question if such rates are available at the time of booking. If the group rate is not available, then comparable lodging may be used, subject to subsection 2, below.
  2. Other Lodging. Travelers must request government rates, when available. In the event that government rates are not available at a given time or in a given area, lodging rates that do not exceed the median retail price for lodging for that area listed on websites like <http://www.priceline.com/> or an equivalent service shall be considered reasonable and hence reimbursable.
- J. Meals.** Each meal expenditure must comply with the limits and reporting requirements of local, state and federal laws. Meal expenses will be reimbursed at the Internal Revenue Service rates for reimbursement of meals as established in Publication 463, or any successor publication.
- K. Telephone/Fax/Cellular.** Officials will be reimbursed for actual telephone and fax expenses incurred on District business. Telephone bills should identify which calls were made on District business. For cellular calls when the official has a particular number of minutes included in the official's plan, the official can identify the percentage of calls made on public business.
- L. Other.** Baggage handling fees of up to \$1 per bag and gratuities of up to 15 percent will be reimbursed. Expenses for which District officials receive reimbursement from another agency are not reimbursable.
- M. Expense Report Content and Submission Deadline.** All cash advance expenditures and expense reimbursement requests must be submitted on an expense report form provided by the District, which must document that the expense in question meets the requirements of this policy, with copies of receipts documenting each expense. Such forms and supporting documentation are public records subject to disclosure under the Public Records Act. Expense reports should be submitted within 30 days of an expense being incurred.
- N. Audits of Expense Reports.** All expenses are subject to verification that they comply with this policy.
- O. Reports to Board.** At the following Board meeting, a report shall be presented on meetings attended at District expense. If multiple officials attended, a joint report may be made.
- P. Compliance with Laws.** District officials should keep in mind that some expenditures may be subject to reporting under the Political Reform Act and other laws. All agency expenditures are public records subject to disclosure under the Public Records Act.

**Q. Violation of this Policy.** Use of public resources or falsifying expense reports in violation of this policy may result in any or all of the following:

1. Loss of reimbursement privileges;
2. A demand for restitution to the District;
3. The District's reporting the expenses as income to the official to state and federal tax authorities;
4. Civil penalties of up to \$1,000 per day and three times the value of the resources used; and
5. Prosecution for misuse of public resources.

#### **10. Authority of Board Members**

Individual members of the Board are not authorized to expend public funds, enter into agreements or contracts, employ staff, sign documents on behalf of the District, or bind the District in any way. This authority can only be granted by motion or resolution of the District Board.



*Serving Our Community Since 1902*

500 Laurel Street, Menlo Park, California 94025-3486 (650) 321-0384 (650)321-4265 FAX

Sergio Ramirez  
District Manager

In reply, please refer to our  
File No.

## **West Bay Sanitary District's List of Designated Filers**

### **Directors:**

Fran Dehn, President  
Roy Allen Thiele-Sardina, Treasurer  
David Walker, Secretary  
Edward P. Moritz, Director  
George B. Otte, Director

### **District Manager**

Sergio Ramirez

### **Legal Counsel**

Anthony P. Condotti, District Counsel  
Barbara H. Choi, Assistant District Counsel  
Victoria Thompson, Assistant District Counsel  
Stephanie Hall, Assistant District Counsel  
Catherine Mary Bronson, Assistant District Counsel

### **District Engineer**

Vacant

### **Consultants**

Michael David Smith, Bank of the West

Effective: 8/12/20

**Procedure for: Swearing in of Board Members and Appointment of Officers  
(and related filings)**

**(A) Swearing in Procedure for Board Members.**

New Board Members shall be sworn in at the first District Board Meeting in January following the election. The swearing in shall be performed by District Legal Counsel or other as determined by the Board. At this meeting, the new Board Members shall be presented with Certificates of Election and shall sign the Oath of Office form provided by the District.

The date the Board Member is sworn in shall constitute the assuming office date of the Board Member.

The District Counsel shall attend the swearing in, as well as any other dignitary the Board decides to invite such as a County Supervisor or Judge.

**(B) Appointment of Officers.**

The District Board shall nominate and appoint Board Officers in the month of December. At the first District Board Meeting in January the newly appointed Board Officers shall be sworn in. The date of assuming office for Board Officers shall be the date the Officer is sworn in or otherwise authorized to serve in the position.

**(C) Form 700 Disclosures.**

Pursuant to California Government Code Section 87202, new District Board Members and Officers must file within thirty (30) days after the assuming office date, a Form 700 Assuming Office Statement reporting any investments, interests in real property, and business positions held on the date the Board Member assumed office. In addition, income received during the 12 months prior to the assuming office date is reportable.

Each year, existing District Board Members must file an annual statement reporting any investments, interests in real property, business positions held, and income received during the period covered by the statement. Generally, the period covered by the statement is January 1 through December 31 of the previous year. The District Board Member shall file the annual statement by April 1, in compliance with the San Mateo County deadline.

When leaving office, District Board Members must file a leaving office statement for the period of January 1 of the current year through the date the Board Member stopped performing the duties of the position.

(D) District Statement of Facts.

Pursuant to California Government Code Section 53051, the District must maintain a statement of the following facts (hereinafter referred to as "Statement of Facts"):

1. The full, legal name of the District.
2. The official mailing address of the District Board.
3. The name and residence or business address of each District Board Member.
4. The name, title, and residence or business address of the president and secretary of the District Board.

Within 10 days after any installation of new officers, or swearing in of board members, or any other changes to the Statement of Facts, the District's Office Manager shall file with the Secretary of State and with the San Mateo County Clerk an amended Statement of Facts, on the Statement of Facts form prescribed by the Secretary of State.

THIS PAGE LEFT INTENTIONALLY BLANK





## WEST BAY SANITARY DISTRICT AGENDA ITEM 12

**To:** *Board of Directors*

**From:** *Sergio Ramirez, District Manager*

**Subject:** *August 12<sup>th</sup> Update Report on District Response to Corona Virus*

---

### **Background**

In early March of 2020, the outbreak of Corona Virus in the USA caused Federal, State and Local governments to enact several laws, regulations and guidelines to mitigate the impact of the spread and severity of the virus including Shelter in Place. The District has been very busy employing measures to meet those regulations and guidelines as well as taking action to ensure the safe working conditions of staff and minimize exposure of and interaction with the public.

### **Analysis**

The District has thus far taken action in regards to: Shelter in Place, Social Distancing, Personal Protective Equipment, and the Injury and Illness Prevention Program (IIPP).

*Shelter in Place:* The District as a wastewater agency has been designated as an “Essential Service” and supplied employees with letters drafted by legal counsel that can be shown to legal authorities, if required, to justify their travel to, during and from work. In addition, the District has developed a Modified Work Schedule that requires individuals to stay at home or telecommute in order to reduce interaction and thus the potential of any spread of the virus among District staff. The District has also implemented the use of Zoom for meetings to reduce the need for consultants, partners, the public and Board member to attend in person. A camera and large screen have been installed to accommodate this mode of virtual meetings.

*Social Distancing:* District staff has employed several measures related to Social Distancing including; limiting meeting size to 10, marking seating spots at tables with 6 foot separation, signage encouraging 6 foot distancing, separation of reporting stations to include the FERRF, Plexi-glass shields at the counter and between workspaces that cannot achieve 6 foot distancing, and closing of the District Office to the public unless by appointment.

---

**Report to the District Board for the Regular Meeting of August 12, 2020**

*Personal Protective Equipment (PPE):* The District has been engaged in supplying employees and Board members with several forms of Personal Protective Equipment and emphasizing the frequent and regular use of this equipment. These items include: The distribution of hand sanitizer to employees and Board members, wipes for counters, chairs and tables, installation of hand sanitizer at counter, tables and offices, N95 masks to all employees, increased counts coveralls, face shields, goggles etc.

This has caused the District to reassess its inventory and at what levels of existing stock should trigger new orders so that the District can maintain adequate levels of important supplies to carry us not only through traditionally thought of natural disasters but pandemics such as this. To that end staff has developed an improved inventory check list that includes contact information for ordering, expected lag times in ordering, minimum levels of stock, Trigger-levels for ordering, dates of stock added to inventory and so on. This should help us be better prepared for future events where PPE can be in short supply or difficult to obtain and District operations can continue uninterrupted.

*Injury and Illness Prevention Program:* The District has made a significant effort in the way of training employees in how to deal with the COVID 19 response. We have developed SOP's for both field staff and office staff in dealing with customers while maintaining social distancing, utilizing PPE, and remote permitting etc. We have complied with local health officials requirement to complete and post at all entrances the Social Distancing Protocols and used that and our SOP's as a basis for developing a comprehensive COVID 19 Preparedness and Response program.

The District has taken great efforts to inform the public of changes in business procedures during this time including website postings, posting notices and information on all entrance doors, mailings of letters and flyers to residents, and ads in Facebook and YouTube. The use of Wipes has emerged as a huge problem for the District and our outreach has included addressing this problem in the flyers, ads, and correspondence to persuade our constituents to refrain from flushing wipes.

*May 13 update:* The District has found that it takes at least 3 weeks from the date of order to delivery of consumable PPE items such as; N95 face masks (we have received 2,000 masks since the first March order), 500 face shields, and 150 goggles to protect the field staff from droplets and mist while cleaning the sewer lines.

The District will now be faced with transitioning back to normal operations. The District Office is expected to re-open in the next week or two. Construction activities are increasing and inspections are being scheduled much more frequently. Social Distancing and PPE will continue to be key elements of District life for the foreseeable future.

*May 27 update:* The District has opened the office to the public on Tuesdays and Thursdays. Stickers on the floors and notices on the doors and shields at the counters have been placed to remain compliant with the Health Dept. Wipes and signs have

been placed in the bathrooms. All the departments except Administration have returned to normal work hours (which are mostly 9/80 schedule but crews are still separated with the Satellite Office/Corp Yard. As a result of these changes have updated the COVID 19 response plan and affixed to entry doors as required.

*June 10 update:* Staff is resuming normal Pre-COVID 19 work schedules beginning June 8, with the exception of some of the Admin staff. Office hours will open up to Monday through Thursday 9am to 3pm.

*June 24 update:* As of Friday, June 12 the Administration Office was open by appointment. Office hours continue to be open Monday through Thursday 9am to 3pm. Staff is continuing to make a concerted effort to be available to the public and contractors for business.

*July 8 update:* The current YouTube advertisement advising customers not to flush wipes or towels has been viewed by 220,653 people and 24% or 50,759 have viewed the video to completion.

*August 12 update:* When an employee has been in contact with a known or possible COVID 19 positive patient or been in contact with someone who has been in contact with a confirmed COVID 19 positive patient they will be asked to stay home for a 14-day self-quarantine period and will be asked to be tested for COVID 19. If the employee is well enough during the self-quarantine period, they will work from home during this time. As soon as the employee is COVID 19 negative, they will be asked to return to work.

### **Fiscal Impact**

While there has been considerable expense to implementing some of the COVID 19 mitigation measures such as; converting the FERRF office space (approx. \$2,000), purchasing PPE for stock (\$8,000 to \$10,000), Public Outreach (\$10,500), Zoom Meeting Equipment (approx. \$6,000) these expenses can thus far be absorbed in the Operating budget due to staff's constant frugal spending practices. The FY2020-21 Budget won't be substantially impacted by the effects of the national COVID 19 response but the following FY2021-22 Budget will be affected to a yet undetermined amount in loss of revenue in the Commercial sector due to the current Shelter in Place mandate.

### **Recommendation**

The District Manager recommends the Board accept this report and provide comments to the District Manager in regards to the report. Additional information may be available at the Board meeting as conditions and responses are rapidly changing throughout the COVID 19 situation.

THIS PAGE LEFT INTENTIONALLY BLANK



## WEST BAY SANITARY DISTRICT AGENDA ITEM 13

**To:** *Board of Directors*

**From:** *Robert Scheidt, Assistant Operations Superintendent  
Sergio Ramirez, District Manager*

**Subject:** *Consideration to Authorize the District Manager to Enter Into a Fleet Equipment Maintenance Agreement with the City of Redwood City*

---

### **Background**

Recently the West Bay Sanitary District (District) and the City of Redwood (City) began discussion to enter into a fleet equipment maintenance agreement. In the District's continuing effort to look for opportunities to partner with other agencies to share or provide services, staff has negotiated and proposed a vehicle and equipment maintenance service agreement between the two agencies (See Attached Agreement).

The District was in contract with the City of Menlo Park but the contract was terminated July 31, 2020 due to Menlo Park budget cuts. Currently, depending on the type of vehicle to be repaired it may require a specialized mechanic at one of the Ford Dealerships, (Mission Valley or Towne Ford). The Dealerships charge \$175.00 an hour and requires a trip, in some cases, to San Jose which results in a loss of productive work hours for District employees.

With the Redwood City Agreement, the District will drop off vehicles at their mechanic shop at the corner of Woodside Road and Broadway in Redwood City. The District will also realize a savings on labor and parts, as outside facilities tend to markup parts on an average of 25 to as much as 50 percent. The City's parts markup will be approximately 15 percent. The District and City have similar types of vehicles so they are accustomed to working on such fleet. In addition, repair parts should be available and down time should be minimal using the City's services.

## **Analysis**

Staff has negotiated a fleet equipment maintenance service agreement with Redwood City which includes:

1. The cost of this service is an hourly rate of \$119.49 which includes overhead costs.
2. Parts and supplies are billed at cost plus 15% to cover overhead costs.
3. The City will submit monthly detailed invoices of work performed.
4. The City will consult with the District before purchasing parts exceeding \$1,000 and parts & labor exceeding \$2,000.
5. The initial term of the agreement is for one year with renewals automatically at one year intervals.
6. The agreement can be terminated with 30 days' notice.
7. The number of vehicles the District has requested the City maintain is approximately 23.

Currently, Redwood City fleet staff maintains several other agency fleets including:

- Town of Atherton (Police vehicles only)
- City of San Carlos (Fire vehicles only)
- Woodside Fire Protection District
- San Mateo County Vehicle Theft Task Force
- San Mateo County Narcotics Task Force
- Port of Redwood City

The City plans to use their existing contract service budget in the fleet section to supplement their existing staff. District staff will evaluate the effectiveness of this venture on a regular basis to ensure that it is an efficient use of District dollars.

## **Fiscal Impact**

Funds will be used out of the approved Operation and Maintenance Budget set at \$55,000 for maintenance and repairs. The agreement is not to exceed \$55,000. The District should realize a saving in staff time but; moreover, potentially in maintenance and repair costs. Additionally, the interagency agreement will allow revenues to remain within the tax and service fee paying community.

## **Recommendation**

The Assistant Operations Superintendent requests the District Board to authorize the District Manager to enter into an agreement with the City of Redwood City to provide fleet equipment maintenance services for West Bay Sanitary District.

Attachment: Fleet Equipment Maintenance Agreement

**AGREEMENT FOR THE CITY OF REDWOOD CITY  
TO PROVIDE FLEET EQUIPMENT MAINTENANCE, REPAIR,  
AND RETROFITTING SERVICES TO WEST BAY SANITARY DISTRICT**

THIS SERVICE AGREEMENT is entered into this 1st day of \_\_\_\_\_, 2020 ("Effective Date"), between the **CITY OF REDWOOD CITY**, a charter city and municipal corporation of the State of California ("Redwood City"), and the **WEST BAY SANITARY DISTRICT**, ("WEST BAY"), (collectively the "Parties").

**RECITALS**

**WHEREAS**, Redwood City operates and maintains a motor vehicle maintenance facility and Redwood City is willing to perform vehicle maintenance and repair services for WEST BAY's Fleet Equipment on an as needed basis at WEST BAY's direction and request; and

**WHEREAS**, WEST BAY also requests that Redwood City provide vehicle retrofitting services, which means adding equipment to designated vehicles, also known as "up-fitting" on an as needed basis at WEST BAY's direction and request; and

**WHEREAS**, WEST BAY agrees to compensate Redwood City for vehicle maintenance, repair and retrofitting services prescribed herein.

**NOW, THEREFORE**, in consideration of these recitals and the mutual covenants contained herein, the Parties agree as follows:

1. **DEFINITIONS.** For purposes of this agreement the following words and terms shall have the meanings respectively ascribed thereto:

(a) "Maintenance Services" means the furnishing of labor and materials necessary or appropriate to perform routine Fleet Equipment maintenance and repair services for WEST BAY based upon Fleet Equipment manufacturer recommendations and to the usual and customary standard pertaining to the furnishing of such services by California municipalities for their own motor vehicles and equipment.

(b) "Retrofitting Services" means installing WEST BAY designated after-market



equipment to WEST BAY designated Fleet Equipment, which generally includes but is not limited to the following equipment: light bars and sirens, advanced electrical and technological components deemed occupationally specific, reinforced safety and security features, which WEST BAY will provide a list of required supplies and equipment to be retrofitted for each designated vehicle.

(c) "Fleet Equipment" means vehicles in the fleet owned by WEST BAY, which generally includes both marked and unmarked motor vehicles of various makes and models.

(d) "Municipal Services Center" means Redwood City's Municipal Services Center, located at 1400 Broadway, Redwood City, California.

## **2. MAINTENANCE AND RETROFITTING SERVICES.**

(a) Redwood City shall provide Maintenance Services and Retrofitting Services on an "as needed" basis based upon Fleet Equipment manufacturer recommendations and upon request of WEST BAY. WEST BAY shall deliver its Fleet Equipment to the Municipal Services Center for Maintenance Services and/or Retrofitting Services and upon completion thereof, take delivery of said Fleet Equipment within a reasonable time. WEST BAY is responsible for scheduling Maintenance Services and Retrofitting Services for each vehicle and upon completion of Maintenance Services, Redwood City shall generally indicate the approximate date of the next recommended maintenance service for such vehicle.

(b) Further, WEST BAY has sole authority and responsibility to schedule or to omit Maintenance Services and Retrofitting Services for any particular motor vehicle or equipment.

**3. COMPENSATION; COSTS; REVISIONS.** WEST BAY shall compensate Redwood City for labor furnished hereunder for Maintenance Services and Retrofitting Services at the hourly rate of One Hundred Nineteen and 49/100 Dollars (\$119.49), including common labor, skilled labor, trained mechanic's services or other labor or services necessary or appropriate for furnishing such Maintenance Services and Retrofitting Services, and shall not

exceed a total of Fifty-five Thousand Dollars (\$55,000) in the first year, absent written agreement of the parties.

WEST BAY shall pay Redwood City for all parts and supplies furnished in connection with such Maintenance Services and Retrofitting Services at the cost thereof to Redwood City.

Redwood City shall submit monthly billing to WEST BAY with a summary sheet and work orders for all work performed, and WEST BAY shall pay Redwood City within fourteen (14) business days of receipt of billing. The hourly rate will remain in effect for one year from the Effective Date of this agreement and can be adjusted by Redwood City at any time thereafter with thirty (30) days written notice; provided, however, that in no event shall the increase or decrease exceed three percent (3%) each year. Notwithstanding the above, if Redwood City's costs escalate beyond the 3% increase due to changes in such things as the PERS contribution and/or employee healthcare costs, the Parties agree to meet and confer on the annual cost increase. Any adjustment to the hourly rate will require a written amendment executed by both Parties indicating the effective date of the adjustment. Redwood City will consult with WEST BAY before conducting major repairs exceeding One Thousand Dollars (\$1,000.00) for parts and/or Two Thousand Dollars (\$2,000.00) for parts and labor combined prior to commencing said work.

**4. INDEMNIFICATION.**

(a). Redwood City hereby agrees to defend, indemnify, and save WEST BAY and its officers, agents, and employees harmless against and from any and all claims, suits, and actions of every name, kind and description, which may be brought against WEST BAY, by reason of any injury to, or death of, any person (including corporations, partnerships and associations) or damage suffered or sustained by any such person arising from, or alleged to have arisen from Redwood City's services provided under this agreement, except as arising from the sole negligence or willful misconduct of WEST BAY.

(b). WEST BAY hereby agrees to defend, indemnify, and save Redwood City and its officers, agents, and employees harmless against and from any and all claims, suits, and

actions of every name, kind and description, which may be brought against Redwood City, by reason of any injury to, or death of, any person (including corporations, partnerships and associations) or damage suffered or sustained by any such person arising from, or alleged to have arisen from, any act or omission to act, arising from or relating to WEST BAY entering the Municipal Service Center in connection with this Agreement or arising from WEST BAY's failure to timely schedule required maintenance or to have maintenance performed as recommended by the manufacturer of the Fleet Equipment, or as recommended by Redwood City in writing, except as arising from the sole negligence or willful misconduct of Redwood City.

(c). The Parties shall waive any rights of recovery for liabilities arising out of the California Workers' Compensation laws, including but not limited to Cal. Labor Code sections 3200 and following.

**5. INSURANCE.** The Parties will obtain and maintain for the duration of the agreement and any and all amendments, coverage against claims for injuries to persons or damage to property which may arise out of or in connection with performance of this Agreement to the extent provided below. Said coverage may be provided by self-insurance and/or through joint powers insurance authority risk pool organized and operated under California law.

(a). Redwood City and WEST BAY will maintain the types of coverages and minimum limits indicated below:

- (1) General Liability with limits of \$2,000,000 per occurrence.
- (2) Automobile Liability with limits of \$1,000,000 per occurrence.
- (3) Workers' Compensation as required by the California Labor Code and Employer's Liability with limits of \$1,000,000 per accident for bodily injury.

**6. ADDITIONAL PROVISIONS.** WEST BAY will ensure that the General Liability and Automobile Liability coverages required under this agreement contain, or are endorsed to contain, provisions requiring Redwood City to be named as an Additional Insured Covered Party.

7. **DISPUTE RESOLUTION.** Should any dispute arise out of this agreement, the Parties shall meet in mediation and attempt to reach a resolution with the assistance of a mutually acceptable mediator. The costs of the mediator, if any, shall be paid for equally by the Parties. If a mediated settlement is reached, neither party shall be the prevailing party for the purposes of the resolution of the dispute. Neither party shall be permitted to file legal action without first meeting in mediation and maintaining a good faith attempt to reach a mediation resolution. Each party will bear their own attorney's fees, if any.

8. **TERM; TERMINATION.** The initial term of this agreement shall be one (1) year commencing from the Effective Date, and further that the term hereof shall be renewable automatically for additional one-year terms in an amount not to exceed Fifty-five Thousand Dollars (\$55,000) per extension term for Maintenance Services and Retrofitting Services, with a maximum term of five years from the Effective Date of this agreement unless terminated earlier by either party in accordance with this section.

Either party may terminate this agreement without cause by giving the other party written notice of not less than thirty (30) days. Redwood City shall be paid for all labor and/or services and all parts and supplies ordered or received up to the termination date.

9. **AMENDMENTS.** Except as provided to the contrary in paragraph 8 above, this agreement may be amended by written agreement, approved and executed by the parties in the same manner as this agreement.

10. **APPLICABLE LAW.** This agreement, its interpretation and enforcement, shall be governed by the laws of the State of California.

11. **PARAGRAPH HEADINGS.** Paragraph headings as used herein are for convenience only, and shall not be deemed to modify or amend the paragraphs headed thereby.

12. **NOTICES.** The name of the persons who are authorized to give written notices or to receive written notice on behalf of Redwood City and on behalf of WEST BAY under this agreement are:

For Redwood City:

City of Redwood City  
Attention: City Manager  
1017 Middlefield Road  
Redwood City, CA 94063

For WEST BAY:

West Bay Sanitary District  
Attention: District Manager  
500 Laurel Street  
Menlo Park CA 94025

Except as otherwise stated, all notices to be provided or that may be provided under this Agreement must be in writing and delivered by regular and certified mail. Each party will notify the other immediately of any changes of address that would require any notice or delivery to be directed to another address.

***(Signatures on Following Page)***

**IN WITNESS WHEREOF**, the parties hereto have executed this agreement on the date first hereinabove written.

**CITY OF REDWOOD CITY**, a charter city and municipal corporation of the State of California

By: \_\_\_\_\_  
Melissa Stevenson Diaz, City Manager

ATTEST:

\_\_\_\_\_  
Pamela Aguilar, City Clerk

APPROVED AS TO FORM:

\_\_\_\_\_  
Veronica Ramirez, City Attorney

**West Bay Sanitary District**

By: \_\_\_\_\_  
Sergio Ramirez, District Manager

APPROVE AS TO FORM:

By: \_\_\_\_\_  
Tony Condotti, Legal Counsel

THIS PAGE LEFT INTENTIONALLY BLANK



**WEST BAY SANITARY DISTRICT  
AGENDA ITEM 14**

**To: Board of Directors**

**From: Sergio Ramirez, District Manager**

**Subject: Discussion and Direction on Recycled Water Projects – Sharon Heights and Bayfront, Including Project Status**

---

A discussion will be held on the Recycled Water Projects – Sharon Heights and Bayfront Facility and other events related to the recycled water project including financing, design/build issues and grant applications. The Board will have opportunity to provide direction to staff and legal counsel.

The following is a disclosure statement required for any document, written report or brochure prepared in whole or in part pursuant to the Finance Agreement with the State Water Resources Control Board for the West Bay Sanitary District Recycled Water Project - Sharon Heights:

*Funding for this project has been provided in full or in part through an agreement with the State Water Resources Control Board. California's Clean Water State Revolving Fund is capitalized through a variety of funding sources, including grants from the United States Environmental Protection Agency and state bond proceeds. The contents of this document do not necessarily reflect the views and policies of the foregoing, nor does mention of trade names or commercial products constitute endorsement or recommendation for use.*



THIS PAGE LEFT INTENTIONALLY BLANK



**WEST BAY SANITARY DISTRICT  
AGENDA ITEM 15**

**To: Board of Directors**

**From: Sergio Ramirez, District Manager**

**Subject: Report & Discussion on South Bayside Waste Management Authority (SBWMA)**

---

The District's representative to South Bayside Waste Management Authority (SBWMA), President Fran Dehn, will report on any pertinent items regarding SBWMA business.

THIS PAGE LEFT INTENTIONALLY BLANK



**WEST BAY SANITARY DISTRICT  
AGENDA ITEM 16**

**To: Board of Directors**

**From: Sergio Ramirez, District Manager**

**Subject: Report & Discussion on Silicon Valley Clean Water (SVCW),  
Including Discussion on SVCW CIP Program and Financing**

---

The District's representative to Silicon Valley Clean Water (SVCW), George Otte, will report on as any pertinent items regarding SVCW Operations, CIP and Finance.

**COMMISSION OF SILICON VALLEY CLEAN WATER  
JOINT POWERS AUTHORITY  
REGULAR MEETING – Monday, July 20, 2020  
8:00 a.m.**

**TO ADDRESS THE *COVID-19 PANDEMIC*, THIS MEETING WILL BE CONDUCTED TELEPHONICALLY OR OTHERWISE ELECTRONICALLY PURSUANT TO THE PROVISIONS OF GOVERNOR NEWSOM’S EXECUTIVE ORDER N-29-20. THE COMMISSION BOARD ROOM WILL BE CLOSED TO THE PUBLIC. THE PUBLIC MAY OBSERVE AND COMMENT BY TELEPHONE OR ELECTRONIC MEANS AS DESCRIBED ON PAGE 6 OF THIS AGENDA.**

**SEE PAGE 6 OF THIS AGENDA FOR MEETING ACCESS INFORMATION AND INSTRUCTIONS**

**COMMISSIONERS**

COUNCIL MEMBER ALICIA AGUIRRE, REDWOOD CITY – CHAIR  
BOARD MEMBER GEORGE OTTE, WEST BAY SANITARY DISTRICT – VICE CHAIR  
COUNCIL MEMBER MARK OLBERT, SAN CARLOS – SECRETARY  
MAYOR WARREN LIEBERMAN, BELMONT – MEMBER

**MANAGER:** TERESA A. HERRERA

**ATTORNEY FOR THE AUTHORITY:** CHRISTINE C. FITZGERALD

**CONTROLLER:** MICHELLE P. FLAHERTY

**TREASURER:** MATTHEW ANDERSON

**AMERICANS WITH DISABILITIES ACT**

In compliance with the Americans with Disabilities Act, if you need special assistance to participate in this meeting, please contact SVCW (650) 591-7121. Notification in advance of the meeting will enable the Authority to make reasonable arrangements to ensure accessibility to this meeting.

**AGENDA**

1. CALL TO ORDER
2. ROLL CALL
3. PLEDGE OF ALLEGIANCE
4. PUBLIC COMMENT

Any member of the public may address and ask questions of the Chair under this item relating to any matter within the Commission’s jurisdiction that does not appear as a separate item on the Agenda. An opportunity will be provided for members of the public to address the Chair and ask questions about any item that is listed on the

agenda at the time the Commission considers the item and before action is taken. If you address the Commission on a non-agenda item, be aware that the Ralph M. Brown Act (Gov. C. § 54950 et seq.) prohibits the Commission from acting on or discussing such matters at this meeting. Any such item may be referred to staff for a decision with regard to placing it on a future agenda for discussion, action or a report. Written comments received within two hours of the beginning of the meeting will be read into the meeting record.

5. SAFETY MOMENT and REPORTS

- A. Safety Moment.....pg. 9
- B. Manager’s Report.....pg. 13
- C. Financial Reports
  - 1. Investment Report.....pg. 17
  - 2. Memorandum from Chief Financial Officer.....pg. 23
- D. Engineering Projects CIP Spend Analysis.....pg. 29
- E. Commission Requested Staff-Level Action Items.....pg. 35
- F. RESCU Program Design-Build Project Status Update.....pg. 41

6. MATTERS OF COMMISSION MEMBER’S INTEREST

- A. Election of New Chairperson, Vice Chairperson and Appoint New Secretary

7. CONSIDERATION OF MOTION APPROVING CONSENT CALENDAR (begins pg. 51)

8. BUSINESS ITEMS

- A. CONSIDERATION OF RESOLUTION APPROVING MANAGER’S FISCAL YEAR 2020-2021 ANNUAL SALARY AND FISCAL YEAR 2019-2020 BONUS (pg. 81)

Proposed Actions:

- i. Chair to summarize recommended action in accordance with Government Code Section 54953(c)(3)
- ii. Move adoption of RESOLUTION APPROVING ANNUAL COMPENSATION FOR THE SILICON VALLEY CLEAN WATER MANAGER

- B. CONSIDERATION OF RESOLUTION APPROVING PUBLIC AGENCIES POST-EMPLOYMENT BENEFITS TRUST ADMINISTERED BY PFM ASSET MANAGEMENT, LLC (pg. 85)

Proposed Action

Move adoption of RESOLUTION OF THE SILICON VALLEY CLEAN WATER COMMISSION APPROVING THE ADOPTION OF THE POST-EMPLOYMENT BENEFITS SECTION 115 TRUST PROGRAM ADMINISTERED BY PFM ASSET MANAGEMENT, LLC TO PREFUND PENSION BENEFIT OBLIGATIONS; AND AUTHORIZE THE MANAGER TO EXECUTE CONTRACT DOCUMENTS

C. CONSIDERATION OF MOTION APPROVING UNDERGROUND FUEL TANK REPLACEMENT (CIP #9041) ENGINEERING DESIGN SERVICES TASK ORDER (pg. 91)

Proposed Action:

Move approval of DESIGN SERVICES TASK ORDER FOR UNDERGROUND FUEL TANK REPLACEMENT (CIP# 9041) IN AN AMOUNT NOT TO EXCEED \$148,800 AND AUTHORIZE MANAGER TO APPROVE UP TO TEN PERCENT CONTINGENCY FOR ADDITIONAL WORK ON AN AS-NEEDED BASIS - KENNEDY/JENKS CONSULTANTS, INC.

9. CLOSED SESSION

A. CONFERENCE WITH REAL PROPERTY NEGOTIATORS

Pursuant to Government Code Section 54956.8

Property Description: 525 Skyway Road, San Carlos

SVCW Negotiators: Kim Hackett, Authority Engineer

Negotiating Parties: Samantha Bechtel, General Manager, Izzy's Steak House

Under Negotiation: Price and terms

10. RECONVENE IN OPEN SESSION – Announce action taken in Closed Session, if any

11. ADJOURN

## CONSENT CALENDAR

### NOTICE TO PUBLIC

All matters listed under CONSENT CALENDAR are considered to be routine. There may be discussion on items on the CONSENT CALENDAR. All items will be enacted by one motion with a voice vote unless members of the Commission, staff, or public request specific items be removed from the CONSENT CALENDAR for separate action.

7. A. APPROVAL OF MINUTES – June 15, 2020 (pg. 51)
- B. CONSIDERATION OF MOTION APPROVING CLAIMS AND CHECKS DATED JUNE 12, 2020 AND JUNE 26, 2020 AND NECESSARY PAYMENTS THROUGH JUNE 26, 2020 (pg. 59)
- C. CONSIDERATION OF MOTION APPROVING CONSTRUCTION CONTRACT CHANGE ORDER FOR WWTP RELIABILITY IMPROVEMENTS PHASE 2 PROJECT (CIP# 9503) (pg. 63)

Proposed Action:

Move approval of CONTRACT CHANGE ORDERS FOR THE WWTP RELIABILITY IMPROVEMENTS PHASE 2 PROJECT (CIP #9503) IN THE AMOUNT OF \$301,399 AND AUTHORIZE MANAGER TO APPROVE UP TO TEN PERCENT CONTINGENCY FOR ADDITIONAL WORK ON AN AS-NEEDED BASIS – C. OVERAA & CO

- D. CONSIDERATION OF MOTION APPROVING ANNUAL GLOBAL TASK ORDER FOR PROFESSIONAL CONSTRUCTION MANAGEMENT SERVICES (pg. 67)

Proposed Action:

Move approval of TASK ORDER SCOPE AND BUDGET FOR CONSTRUCTION MANAGEMENT SERVICES IN AN AMOUNT NOT TO EXCEED \$3,625,000 AND AUTHORIZE MANAGER TO APPROVE UP TO TEN PERCENT CONTINGENCY FOR ADDITIONAL WORK ON AN AS-NEEDED BASIS - TANNER PACIFIC INC.

- E. CONSIDERATION OF MOTION APPROVING FINAL ACCEPTANCE OF THICKENING IMPROVEMENTS – PHASE 1 PROJECT (CIP #9168) AND AUTHORIZATION TO FILE NOTICE OF COMPLETION (pg. 71)

Proposed Action:

Move approval of MOTION TO ACCEPT THICKENING IMPROVEMENTS - PHASE 1 PROJECT (CIP #9168) AND AUTHORIZE FILING NOTICE OF COMPLETION – C. OVERAA & CO

- F. CONSIDERATION OF RESOLUTION APPROVING AGREEMENT FOR GRANT FUNDING FROM THE U.S. BUREAU OF RECLAMATION (pg. 77)



Proposed Action:

Move adoption of RESOLUTION ACCEPTING GRANT FUNDING, AUTHORIZING MANAGER TO NEGOTIATE AGREEMENTS WITH THE UNITED STATES BUREAU OF RECLAMATION, STANFORD UNIVERSITY, AND RELATED CONTRIBUTORS AND APPROVING EXECUTION OF SAID AGREEMENTS