

*1902 - Serving Our Community for 120 Years - 2022*  
WEST BAY SANITARY DISTRICT  
AGENDA OF BUSINESS  
REGULAR MEETING OF THE DISTRICT BOARD  
WEDNESDAY, OCTOBER 26, 2022 AT 7:00 P.M.  
RONALD W. SHEPHERD ADMINISTRATION BUILDING,  
500 LAUREL STREET, MENLO PARK, CALIFORNIA 94025

**Board Members**

Fran Dehn, President  
David Walker, Secretary  
Roy Thiele-Sardiña, Treasurer  
Edward P. Moritz, Member  
George Otte, Member



**General Manager**

Sergio Ramirez

**District General Counsel**

Anthony Condotti, Esq.

**AGENDA OF BUSINESS**

**NOTICE OF PUBLIC PARTICIPATION BY TELECONFERENCE or ZOOM ONLY**

Pursuant to California Assembly Bill 361, members of the West Bay Sanitary District Board of Directors and Staff may participate in this meeting via a teleconference. In the interest of reducing the spread of COVID- 19, members of the public are allowed to participate telephonically only, and may submit comments in advance by email addressed to [treese@westbaysanitary.org](mailto:treese@westbaysanitary.org) by 4:00 p.m. on Wednesday, October 26<sup>th</sup>.

To participate by telephone or Zoom meeting, public comments can be made by joining Zoom meeting at:

<https://us06web.zoom.us/j/83232334152?pwd=Wmk5UlltNXpqaTFNqjVBK1ByNktZZz09>

Meeting ID: 832 3233 4152 Passcode: 302757

Or by phone, call: 1-669-900-6833 Meeting ID: 832 3233 4152 Passcode: 302757

Following receipt of public comment and open session items, the Board will adjourn to closed session. Reportable action, if any, will be available upon inquiry within twenty-four (24) hours.

***NOTE: The Board may take action on any agendized item unless specifically designated a “discussion” item or a “report.”***

1. Call to Order and Roll Call
2. Communications from the Public
3. Consent Calendar

*Matters listed under this item are considered routine and will be enacted by one motion. The motion, seconds, and vote are applicable to any included resolutions and recorded accordingly. There will be no separate discussion of these items unless specifically requested by a member of the Board.*

- A. Approval of Minutes for Regular Meeting October 12, 2022 Pg. 3A-1

4. General Manager's Report Pg. 4-1
5. Consideration to Award Bayfront Park Sanitary Sewer Improvement Project to Ranger Pipelines Pg. 5-1
6. Consider Approving Proposal and Authorize the General Manager to Enter Into an Agreement for On-Call Construction Consultation Services with Freyer & Laureta, Inc. (F&L) for the Bayfront Park Sanitary Sewer Improvement Project Pg. 6-1
7. Consider Approving District Treasury Report First Quarter Fiscal Year 2022-23 Pg. 7-1
8. Consider Approving Purchase of a 2022 Ford Mach E to replace Vehicle Unit No. 201 assigned to the General Manager Pg. 8-1
9. Discussion and Direction on Sharon Heights Recycled Water Plant Pg. 9-1
10. Discussion and Direction on Bayfront Recycled Water Project and Status Update Pg. 10-1
11. Report and Discussion on South Bayside Waste Management Authority (SBWMA) Pg. 11-1
12. Report and Discussion on Silicon Valley Clean Water (SVCW) Plant Pg. 12-1
13. Comments or Reports from Members of the District Board and Consider Items to be Placed on Future Agenda
14. Adjournment

The West Bay Sanitary District does not discriminate against persons with disabilities. Upon request, the agenda and agenda packet can be provided in a format to accommodate special needs. If you require a copy of the agenda or related materials in an alternative format to accommodate a disability, or if you wish to attend this public meeting and will require special assistance or other special equipment, please call the District at (650) 321-0384 at least five days in advance and we will make every reasonable attempt to provide such an accommodation.



*1902 - Serving Our Community for over 115 Years - 2022*

**WEST BAY SANITARY DISTRICT  
MINUTES OF THE REGULAR MEETING OF THE DISTRICT BOARD  
WEDNESDAY, OCTOBER 12, 2022 AT 7:00 P.M.**

**1. Call to Order**

President Dehn called the meeting to order at 7:00 PM

**Roll Call**

BOARD MEMBERS PRESENT: President Dehn, Secretary Walker, Treasurer Thiele-Sardiña, Director Moritz, Director Otte

BOARD MEMBERS ABSENT: None

STAFF MEMBERS PRESENT: Ramirez, Hulsmann, and by Zoom Reese and Condotti

Others Present: Rick Simonson and Dave Hilton HF&H, Evan Boyd – Recology, Eileen - CCR

**2. Communications from the Public: None.**

**3. Public Hearing - Annexing Certain Territory Within the West Bay Sanitary District's On-Site Wastewater Disposal Zone – Lands of Kaveh (1195 Westridge Drive, Portola Valley)**

Motion to Open by: Moritz 2<sup>nd</sup> by: Walker Vote: AYE: 5 NAY: 0 Abstain: 0

Discussion/Comments: None.

Motion to Close by: Moritz 2<sup>nd</sup> by: Otte Vote: AYE: 5 NAY: 0 Abstain: 0

**4. Consider Adopting Resolution Ordering Annexation of Certain Parcels in the Territory of West Bay Sanitary District to the West Bay Sanitary District's On-Site Wastewater Disposal Zone Including Certain Determinations, Findings and Declarations of the District Board – Lands of Kaveh (1195 Westridge Drive, Portola Valley)**

Motion to Approve by: Moritz 2<sup>nd</sup> by: Thiele-Sardiña Vote: AYE: 5 NAY: 0 Abstain: 0

Discussion/Comments: None.

## 5. Consent Calendar

### CONSIDERATION OF ITEM(S) REMOVED FROM THE CONSENT CALENDAR

Discussion/Comments: None.

- A. Approval of Minutes for Regular Meeting September 28, 2022
- B. Approval of the Financial Activity Report Authorizing Payment of Certain Bills and Salaries and Consideration of Other Financial Matters thru September 30, 2022
- C. WBSD Operations and Maintenance Report – September 2022
- D. Town of Los Altos Hills Operations and Maintenance Report for Work Performed by WBSD – September 2022
- E. Town of Woodside Operations and Maintenance Report for Work Performed by WBSD – September 2022
- F. Consider Approval of Resolution Authorizing District to Implement Teleconferenced Public Meetings Pursuant to Assembly Bill 361
- G. Consideration of Resolution Consenting to Annexation of Territory to the West Bay Sanitary District by the San Mateo County Local Agency Formation Commission – 1195 Westridge Drive, Portola Valley (079-011-050), Lands of Kaveh

Motion to Approve by: Walker 2<sup>nd</sup> by: Moritz Vote: AYE: 5 NAY: 0 Abstain: 0

## 6. General Manager's Report

Discussion/Comments: General Manager Ramirez reported the District is considering Engineering Data Software Inc. as a new tax roll billing system to replace the much older Computer Optimization of Sewer Maintenance Operations (COSMO) program. He also reported that the Bayfront Park Sanitary Sewer Improvements Project bids are due on October 18<sup>th</sup>. He continued to report there is a Master Plan pre-proposal meeting on October 17<sup>th</sup>. General Manager Ramirez informed the Board the District will sponsor a booth at the Halloween Hoopla on October 29<sup>th</sup> as part of our outreach efforts. He also discussed that the next Board meetings will be on Oct. 26<sup>th</sup> and November 9<sup>th</sup>, as well as, the Thanksgiving Lunch on November 8<sup>th</sup> and the Holiday luncheon on December 8<sup>th</sup>. Lastly, he also reported the annual Almanac Newsletter on December 9<sup>th</sup> will coincide with the District's 120<sup>th</sup> anniversary on December 10<sup>th</sup>. The complete General Manager's written report is in the October 12, 2022 agenda packet.

## 7. 2023 Solid Waste and Recycling Collection Rate Study Draft Workshop and Direction

Discussion/Comments: Rick Simonson of HF&H presented the draft rate study report which included a slight increases of rates in 2023 for most residential carts.

## 8. Consider Accepting the HF&H Solid Waste Rate Study, Set a Public Hearing for December 14, 2022 to Review Proposed Rates for the Year 2023 and Provide Direction by Minute Order Regarding the Rate Adjustment and Proposition 218 Notice for a Public Hearing

Motion to Approve by: Moritz 2<sup>nd</sup> by: Thiele-Sardiña Vote: AYE: 5 NAY: 0 Abstain: 0

Discussion/Comments: None.

**9. Consider Accepting the Performance Merit Pay Program Results from Oct. 1, 2021 to Sept. 30, 2022 and Authorize the General Manager to Disburse the Final Payout**

Motion to Approve by: Thiele-Sardiña 2<sup>nd</sup> by: Moritz Vote: AYE: 5 NAY: 0 Abstain: 0

Discussion/Comments: Operations Superintendent Robert Hulsmann gave a presentation on the Performance Merit Pay Program results. He reported District staff achieved 98% of the goals which equals a maximum individual merit payout of \$4,900.00 for each regular, full-time employee.

**10. Consider Authorizing the General Manager to Consent to the Abandonment of Public Utility Easement at 1715 Bay Laurel Drive, Menlo Park**

Motion to Approve by: Thiele-Sardiña 2<sup>nd</sup> by: Walker Vote: AYE: 5 NAY: 0 Abstain: 0

Discussion/Comments: General Manager Ramirez reported this is a public utility easement which is not used for a District sewer main.

**11. October 12, 2022 Update Report on District Response to Corona Virus**

Discussion/Comments: General Manager Ramirez reported the District's engineering consultant tested positive for COVID-19. It appears no District employees were in close contact with the person.

**12. Report and Discussion on Sharon Heights Recycled Water Plant**

Discussion/Comments: General Manager Ramirez reported that 8.6 million gallons was treated in September and 6.7 MGD delivered. He also reported \$200,000 was approved in a SRF loan for the Avy Altschul Pump Station along with a \$300,000 grant.

**13. Discussion and Direction on Bayfront Recycled Water Project and Status Update**

Discussion/Comments: General Manager Ramirez reported the California Water State Revolving Fund loan was approved in the amount of \$37 million. He also reported an additional \$15 million was approved for the project from the Water Recycling Funding Program Grant. This reflects the estimated \$52 million total cost of the Recycled Water Facility and distribution system. The Board of Directors were very pleased with the State Water Board.

**14. Report & Discussion on South Bayside Waste Management Authority (SBWMA)**

Discussion/Comments: None.

**15. Report, Discussion & Direction on Silicon Valley Clean Water (SVCW) and Discussion on SVCW CIP Program and Financing**

Discussion/Comments: Director Otte reported the Commission approved a \$600,000 change order for piping to one of the plant's digesters.

**16. Comments or Reports from Members of the District Board and Consider Items to be Placed on Future Agenda**

Discussion/Comments: None.

**17. Adjournment Time:** The meeting was adjourned at 8:28 PM

---

Secretary



**To:** *Board of Directors*

**From:** *Sergio Ramirez, General Manager*

**Subject:** *General Manager's Report*

---

**1) Administrative:**

- a. The District will participate in the Menlo Park Halloween Hoopla parade and carnival on Saturday, October 29<sup>th</sup>.
- b. Villalobos and Associates Inc. will begin the flow monitoring and hydraulic engineering study on the wastewater flows in every basin throughout the District. Flow Meters are being installed this month. The data will assist with the preparation of the 2023 Master Plan.

**2) Finance:**

- a. Finance Manager, Debra Fisher, continues to work with the District's Auditors.
- b. Staff is reviewing options to replace the District's outdated database and other software with more user friendly software to assist in the preparation of the Tax Roll.

**3) CIP Projects:**

**a. Construction Capital Improvement Program (CIP):**

- i. The bid opening for the Bayfront Park Sewer Improvements Project was held on October 18, 2022 at 2:00PM. Five bids were submitted ranging from \$3.1 million to \$5.5 million. The one and only original bid was rejected by the Board earlier this year in the amount of \$3.6 million.
- ii. Freyer & Laureta Inc. is coordinating the public sewer main project with the City of Menlo Park at the intersection of Ravenswood and Laurel St. The City agreed to reasonable paving requirements because they will be paving the area following the pipeline repairs.
- iii. Two pipeline segments in an easement at Albern Street and Menalto Avenue will be replaced. The project was approved by the Board at the September 14th Regular Board Meeting.

**b. Levee Improvement Project:**

- i. United States Army Corps of Engineers' (USACE) 30 day comment period ended. Public comments were minimal. The consultants and staff prepared comments and have sent them to the USACE. The District should receive permits by December 2022 so the project can go to bid by January 2023.

---

**Report to the District Board for the Regular Meeting of October 26, 2022**

Additional information or topics may be introduced by the GM verbally during the Board meeting.

4) **Information Technology (IT):**

- a. Staff is migrating the Abila Software to MIP Cloud based Abila this should make the MicroIX purchase order process more seamless and easier to report from.
- b. Staff will be meeting with Microsoft representatives to discuss Microsoft Office 365 plans including their government rate plan.

5) **Operations and Maintenance:**

a. **Collection System:**

- i. Crews are close to being on schedule with the 12 month high frequency cleaning list. The schedule consists of all 6, 8, and 10 inch pipes throughout the District and over 100 linear miles. These pipes are cleaned every year to avoid Sanitary Sewer Overflows (SSOs).

b. **Pump Facilities:**

- i. The pump crews and the Operations Superintendent continue to evaluate the telemetry system for the pump stations. The current ISAC System has been in place for over twenty years and will no longer be supported. The system uses telephone lines and dial-up modems to communicate alarms.

c. **Training:**

- i. Staff will receive training on the updated Sewer System Management Plan approved by the Board of Directors on September 28, 2022.

6) **Water Quality:**

a. **Sharon Heights Golf and Country Club (SHGCC):**

- i. Staff conducted flow analysis for the Avy Altschul Pump Station project to study the flows now that most people have returned to work after the pandemic. Flows appear to be down to 40,000 to 60,000 per day rather than 90,000 per day in 2021. SHGCC was made aware of the findings at the October 11, 2022 O&M meeting.
- ii. The State's SRF program has added the Avy Altschul Pump Station to its Intended Use Plan and is now on the fundable list due to its water resiliency component.

b. **Bayfront Recycled Water Facility (BRWF):**

- i. The State's SRF program has added the Bayfront Reclaimed Water Facility project to its Intended Use Plan. The initial approval is for \$52 million.
- ii. Staff met with Signature Group over the MOU to deliver recycled water to the Willow Village Project which has gained momentum in recent days. We should begin the Project Management and 30% design shortly.
- iii. The City of Menlo Park Staff will bring the Recycled Water Purveyor MOU to the City Council in November. This will establish the District as the reclaimed water provider for the Bayfront Recycled Water Facility within the City's service area.

c. **Woodside Recycled Water Facility (BRWF):**

- i. The kickoff meeting for the Woodside Recycled Water Facility feasibility was held on September 22, 2022. Several options will be considered including reclaimed water supply from Silicon Valley Clean Water and Redwood City.

---

**Report to the District Board for the Regular Meeting of October 26, 2022**

Additional information or topics may be introduced by the GM verbally during the Board meeting.



- 7) **Fleet and Facilities:**
  - a. **Vehicle Maintenance:**
    - i. The new electric vehicle has arrived at Towne Ford in Redwood City. After speaking with the dealership about leasing, the lease options were not favorable.
- 8) **Personnel:**
  - i. The recruitment for the Project Manager position is underway. To date we have received several applications.
- 9) **Upcoming Events:**
  - a. **Next Regular Board Meetings:** Wednesdays, October 28<sup>th</sup> and November 9<sup>th</sup>.
  - b. **PMPP Luncheon:** Tuesday, November 8<sup>th</sup>
  - c. **End of Year Holiday Luncheon:** Thursday, December 8<sup>th</sup>.
- 10) **Misc. Items:**
  - a. **LAFCo:** Talks with San Mateo County and LAFCo regarding the divestiture of the Solid Waste Franchise have begun.
  - b. **West Bay:** The District has experienced 2 sanitary sewer overflow (SSO) in 2022.
  - c. **Town of Los Altos Hills:** Crews continue to clean and video inspect the Town's system.
  - d. **Town of Woodside:** Crews will be cleaning the entire system for the Town at the end of the year.

---

**Report to the District Board for the Regular Meeting of October 26, 2022**

Additional information or topics may be introduced by the GM verbally during the Board meeting.

THIS PAGE LEFT INTENTIONALLY BLANK



## WEST BAY SANITARY DISTRICT AGENDA ITEM 5

**To:** *Board of Directors*

**From:** *Sergio Ramirez, General Manager*

**Subject:** *Consideration to Award Bayfront Park Sanitary Sewer Improvement Project to Ranger Pipelines Incorporated*

---

### Background

The entrance of Bayfront Park in Menlo Park is the location of significant upcoming projects. Two major diversion projects were performed earlier this year. They included the Bayfront Canal/Atherton Channel Project and the South Bay Salt Pond Restoration Project. In addition to this, the City of Menlo Park is currently in the design phase of improvements to the park's entrance.

The District has a need for significant work within this same area. The work includes the rerouting of three trunk sewer pipelines for the benefit of a future influent pump station. This future influent pump station will pump to the Bayfront Recycled Water Facility at the Flow Equalization and Resource Recovery Facility (FERRF). The other significant work includes replacing portions of the 30-inch and 36-inch sewer main along Bayfront Expressway at the front of the park entrance. These segments were discovered to be in poor condition during the District's large-diameter CCTV project.

Coordination on these major projects has greatly benefitted all agencies involved and the community as a whole. The District has contracted engineering, surveying, and design services from Freyer & Laureta, Inc. for the needed work. The engineer plan is to aligning all pipelines in order to avoid future disruption of the City's improvements to the Park entrance area and beyond drainage improvement recently installed near the park's entrance.

### Analysis

The anticipated cost for construction of the project was approximately \$2,855,000.00. The bid opening for this project was on October 18, 2022 at 2:00 PM. It is understood that the project shall be awarded to the lowest responsible bidder. The District received a total of five (5) bids, which were as follows:

<b>Bidder</b>	<b>City</b>	<b>Bid Total</b>
Ranger Pipelines, Inc.	SF	\$3,130,113
JMB Construction, Inc.	So. SF	\$3,589,305
Precision Engineering, Inc.	SF	\$3,863,525
Power Engineering Construction Co.	Alameda	\$4,274,377
Anvil Builders, Inc.	Emeryville	\$5,486,750

**Fiscal Impact**

The Capital Assets Fund for Fiscal Year 2022-2023 has an approved budget for Pipeline Replacement and Rehabilitation Construction for Bayfront Park Sanitary Sewer Improvements of \$1.25 million in addition to \$1.25 million for Reclaimed Water Pipelines for a total of \$2.5 million. The lowest responsible bid is \$3,130,113.00.

In addition to the \$630,113.00 shortfall, staff is requesting the appropriation of approximately 15% contingency (10% for additional work and 5% for construction support services). The additional 15% contingency is estimated at \$469,516.95. The total project amount requested is \$3,599,629.95.

The additional \$1,099,629.95 will be used out of the Recycled Water Cash Flow Reserves of \$2,348,647 currently in Local Agency Investment Fund (LAIF) with the California State Treasurer’s Office.

**Recommendation**

The General Manager recommends that the Board: 1) adopt the attached Resolution and authorize the General Manager to award the contract for the Bayfront Park Sanitary Sewer Improvements Project to the low bidder, Ranger Pipeline Inc. of San Francisco for the amount of \$3,130,113, which includes the recycled water pipelines; 2) apportion an additional \$469,516.95 (15%) for contingency for a total project amount of \$3,599,629.95.

Attachment: Resolution

RESOLUTION NO. \_\_\_\_\_(2022)

**RESOLUTION AWARDING A CONSTRUCTION CONTRACT FOR THE BAYFRONT PARK SANITARY SEWER IMPROVEMENT PROJECT TO RANGER PIPELINES INCORPORATED AND ALLOCATE FUNDS FOR CONSTRUCTION**

\*\*\*\*\*

**WHEREAS, Bayfront Park Sanitary Sewer Improvement Project** plans and specifications were prepared by Freyer & Laureta, Inc. of San Mateo, California, and

**WHEREAS,** Ranger Pipelines is the lowest bidder for the project, and

**WHEREAS,** there was no irregularity or material defect in Ranger Pipelines' bid package, and

**WHEREAS,** Ranger Pipelines' base bid amount was \$3,130,113.00 and

**WHEREAS,** this was the lowest responsible and responsive base bid, and

**WHEREAS,** based on available funds, the Bid be awarded to Ranger Pipelines for \$3,130,113.00, and

**WHEREAS,** the Capital Assets Fund for Fiscal Year 2022-2023 for this project was proposed for \$2,500,000.00; however, \$3,599,629.95 is now allocated to this project.

**NOW, THEREFORE, BE IT RESOLVED** that the District Board of the West Bay Sanitary District, County of San Mateo, State of California, does hereby award a construction contract to Ranger Pipelines in the amount of \$3,130,113.00 for the **Bayfront Park Sanitary Sewer Improvement Project** and, subject to review and approval as to form by District's General Counsel, authorizes the General Manager to execute the construction contract, and allocate an additional \$469,516.95 for construction contingencies and construction support services out of the Recycled Water Cash Flow Reserves.

\*\*\*\*\*

PASSED AND ADOPTED by the District Board of the West Bay Sanitary District at a regular meeting thereof held on the 26<sup>th</sup> day of October, 2022, by the following votes:

Ayes:

Noes:

Absent:

Abstain:

---

President of the District Board of the  
West Bay Sanitary District of San  
Mateo County, State of California

Attest:

---

Secretary of the District Board of the  
West Bay Sanitary District of San Mateo  
County, State of California



## WEST BAY SANITARY DISTRICT AGENDA ITEM 6

**To:** *Board of Directors*

**From:** *Sergio Ramirez, General Manager*

**Subject:** *Consider Approving Proposal and Authorize the General Manager to Enter Into an Agreement for On-Call Construction Consultation Services with Freyer & Laureta, Inc. (F&L) for the Bayfront Park Sanitary Sewer Improvement Project*

---

### Background

Construction projects publicly bid by the District require the consultation of the design engineer to assist the District in obtaining construction work that is in substantial conformance with the project contract documents. Furthermore, the District's Construction Inspector may need additional help during the construction of Bayfront Park Sewer Improvement project. The Construction Inspector has other ongoing obligations that require inspections such as lateral and sewer main extensions (Class 3 permits). F&L has prepared a proposal for assistance through construction which includes:

- Providing interpretation of contract documents to address contractor Requests for Information, assisting in the preparation of change orders, reviewing extra work requests, and reviewing shop drawings and other contractor submittals.
- Coordination with the contractor.
- Coordinating with the City of Menlo Park, Caltrans, SVCW, and Cargill.
- Preparing Record Drawings at the end of the project.
- Attending meetings with the Contractor, as requested by the District.
- Providing construction observation services on an as-needed, on-call basis.
- Providing construction contract and contractor payment coordination.

### Analysis

Pursuant to the Professional Consultants Selection Policy, the policy states the General Manager may approve any contract for Professional Services less than \$75,000 and less than \$100,000 if budgeted. The policy also states the District Board must review and approve any contract for Professional Services to any firm to which the District has awarded an aggregate of \$300,000 in Consulting Agreements within the preceding 12-

---

month period regardless of the amount of the contracts/agreements/amendments. The District has awarded an aggregate amount of \$630,095 to Freyer & Laureta, Inc. within the last 12 months. This includes staff augmentation engineering services and an extension to the levee permitting agreement.

Fiscal Impact

The Capital Assets Fund for Fiscal Year 2022-2023 has an approved budget for Pipeline Replacement and Rehabilitation Construction for Bayfront Park Sanitary Sewer Improvements of \$1.25 million in addition to \$1.25 million for Reclaimed Water Pipelines for a total of \$2.5 million. The total bid for construction for this project is \$3,130,113.

The proposed agreement for On-Call Construction Consultation Services with F&L is not to exceed \$70,000.00 without District approval.

Recommendation

The General Manager recommends the Board approve the proposal and authorize the execution of an agreement with Freyer & Laureta Inc. for On-Call Construction Consultation Services for \$70,000.00.

Attachment: Freyer & Laureta, Inc. Proposal dated October 20, 2022.



October 20, 2022

Mr. Sergio Ramirez  
General Manager  
West Bay Sanitary District  
500 Laurel Street  
Menlo Park, California 94025

**Re: ON-CALL CONSTRUCTION CONSULTATION SERVICES  
BAYFRONT PARK SANITARY SEWER IMPROVEMENT PROJECT**

Dear Mr. Ramirez,

Thank you for your proposal request for on-call construction administration services for the Bayfront Park Sanitary Sewer Improvement Project. We are pleased to present the following Scope of Professional Services and Fee Schedule.

## Description of Services

Construction administration services will be provided to the District on an on-call basis for the subject project, to assist the District in obtaining construction work that is in substantial conformance with the project contract documents.

### Task 1. On-Call Construction Administration Services

Our construction administration services will consist of the following:

- Provide interpretation of contract documents to address contractor Requests for Information, assist in the preparation of change orders, review extra work requests, and review shop drawings and other contractor submittals.
- Coordinate AutoCAD file transfer to Contractor if requested and as directed by the District.
- Provide consultation and prepare drawings as needed to address and resolve pipeline conflicts during construction.
- Coordinate construction with the City of Menlo Park, Caltrans, SVCW, and Cargill.
- Prepare Record Drawings at the end of the project.
- Attend meetings with the Contractor, as requested by the District.
- Provide construction observation services on an as-needed, on-call basis.
- Provide construction contract and contractor payment coordination.

#### Headquarters

150 Executive Park Blvd, Suite 4200  
San Francisco, CA 94134  
Tel: (415) 534-7070

#### North Bay Office

505 San Marin Drive, Suite A220  
Novato, CA 94945  
Tel: (415) 534-7070

#### East Bay Office

825 Washington Street, Suite 237  
Oakland, CA 94607  
Tel: (510) 937-2310

Mr. Sergio Ramirez  
Page 2 of 2  
October 20, 2022

## Proposed Fee

All work will be on a time and materials (T&M) basis, not exceed the following limits without District authorization:

On-Call Construction Administration Services    \$70,000 (budget)

Thank you for the opportunity of submitting this proposal to you. We look forward to working with you on another successful project. If you have any questions, please feel free to call us.

Very truly yours,

**FREYER & LAURETA, INC.**

A handwritten signature in black ink, appearing to read "Richard J. Laureta". The signature is written in a cursive, flowing style.

**Richard J. Laureta, P.E.**  
**President**



## WEST BAY SANITARY DISTRICT AGENDA ITEM 7

**To:** *Board of Directors*

**From:** *Debra Fisher, Finance Manager*

**Subject:** *Consider Approving District Treasury Report  
First Quarter FY 2022-23*

---

### **Background**

In October 2010 the District named Bank of the West as the District's Investment advisor and approved an investment of \$5 million in available funds to establish the Emergency Capital Reserve. Subsequently, the Board has established several additional reserves to provide financial stability for the District.

Excess funds over the current monthly expenditures are held in the Local Agency Investment Fund (LAIF), which are equivalent to cash and may earn higher yields without a long term commitment. Operating Reserves, customer deposits, current capital projects, and Solid Waste Funds are held in LAIF.

Restricted funds for Sharon Heights Golf & Country Club (SHGCC), as required for the Clean Water State Revolving Fund (SRF) loan are held in a Money Market account, as requested by SHGCC representatives.

There are currently five separate investment reserves maintained to support the goals of the District, along with reserves held in LAIF, the Vehicle & Equipment Reserve held in a money market account, a Pension Trust, and the restricted Recycled Water SRF Reserve. Annual contributions are made in accordance with the Board approved budget in order to reach the target balances for each reserve.

<b><u>Reserve Account</u></b>	<b><u>Originated</u></b>	<b><u>Target Balance</u></b>	<b><u>Target</u></b>
Operating Reserve	11/26/2014	\$11 million *	Achieved
Rate Stabilization Reserve	10/30/2015	\$10 million	Unfulfilled
Treatment Plant Reserve	9/24/2021	\$12 million	Unfulfilled
Capital Project Reserve	11/26/2014	\$6 million	Unfulfilled
Emergency Capital Reserve	10/19/2010	\$5 million	Unfulfilled
Recycled Water Cash Flow	11/18/2016	\$8 million	Unfulfilled
Recycled Water SRF Reserve	3/01/2018	\$1.46 million	Achieved
Vehicle & Equipment Reserve	8/18/2011	\$1 million	Achieved

\* Based on approved FY 2022-23 Budget, 6 months Operations \$11,111,437 (held in LAIF)

### **Fiscal Impact**

The District had \$71,653,384 in cash and investments, including \$2,106,689 in restricted accounts, as of September 30, 2022.

The District allocated an additional \$361,837 of LAIF funds for the Operating Reserve, as approved in the FY 2022-23 budget, to meet six months of expenditures. Transfers of \$3.6 million approved in the FY 2022-23 Budget are not yet completed.

**FY 2022-23 Approved Budget Transfers**

Operating Reserves	\$ 361,837
Treatment Plant Reserve	2,500,000
Rate Stabilization	300,000
Capital Project Reserve	200,000
Emergency Capital Reserve	200,000
Vehicle & Equip Replacement Reserve	389,881
<b>Total Transfers</b>	<b><u>\$ 3,951,718</u></b>

The District had total funds of approximately \$15.4 million above the total \$54 million target reserve balances, combining all District unrestricted accounts, as of September 30, 2022. Four reserve accounts are under the individual targets by approximately \$835 thousand, due to fluctuations in market values. The goal is to achieve the new Treatment Plant Reserve \$12 million target in five years with contributions of \$2.5 million per year beginning in FY 2021-22.

The investment portfolios have been set up with the goal to yield a rate of return of approximately 2%. Current District yields in the Investment Reserves average 1.87%.

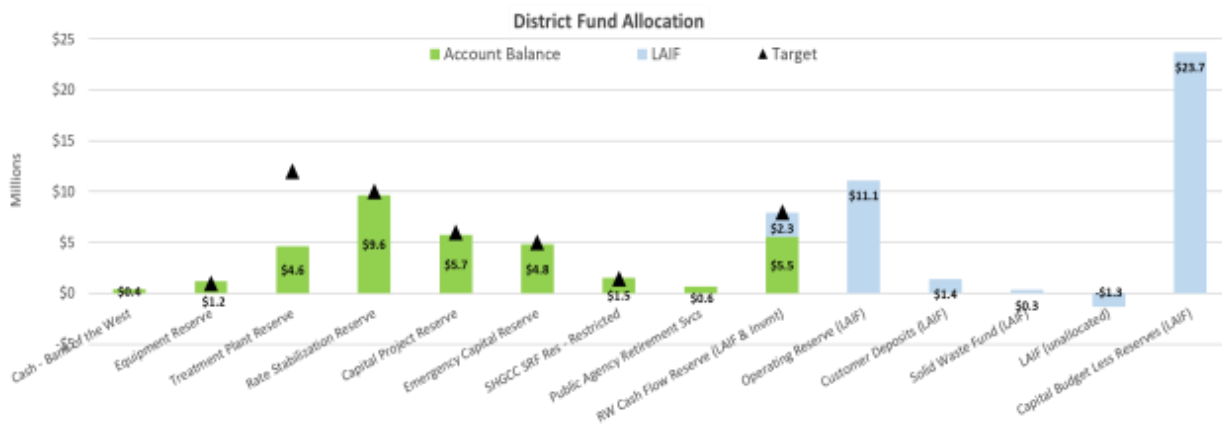

Details of each account are included on the following Schedule of Cash and Investments. The Investment statements for the first quarter FY 2022-23 follow, including details of all holdings and activity.

**Recommendation**

The Finance Manager recommends the District Board approve the report on the District’s Treasury Report, including investment portfolio statements detailing assets held, transactions, and changes in market value to the Reserve accounts described therein, for the first quarter fiscal year 2022-23.

Attachment: Schedule of Cash and Investments, September 30, 2022  
Investment Statements 1<sup>st</sup> Quarter FY 2022-23

**West Bay Sanitary District  
Schedule of Cash and Investments  
Fiscal Year 2022-23  
September 30, 2022**

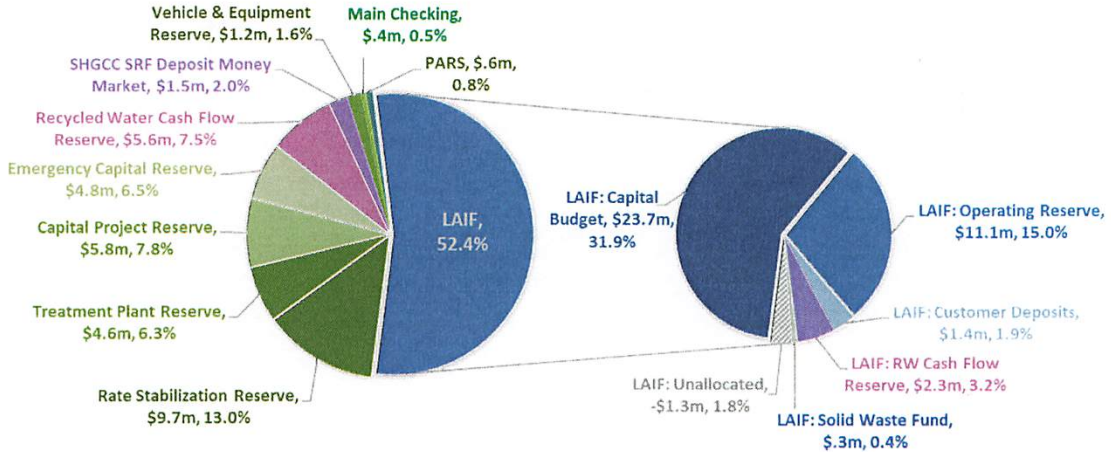

Description	Target	Cash & Equivalents	Fixed Income	Accrued Interest	Yield
Bank of the West, Commercial Account		359,815.60			0.00%
NAVIA Commuter Checking Account		2,486.30			0.00%
Petty Cash		800.00			
Bank of the West Money Market Account		1,189,762.27			0.18%
Local Agency Investment Fund (LAIF)		37,535,312.18		0.00	0.32%
<b>Cash &amp; Equivalent Accounts</b>		<b>39,088,176.35</b>		<b>0.00</b>	
<b>Bank of the West Reserves Accounts</b>					
Bank of The West - Rate Stabilization Reserve	\$10 million	432,616.17	9,174,166.59	49,488.39	2.08%
Bank of The West - Treatment Plant Reserve	\$12 million	15,152.59	4,610,580.70	16,496.26	1.53%
Bank of The West - Capital Project Reserve	\$6 million	272,611.09	5,477,340.25	24,845.11	1.73%
Bank of The West - Emergency Capital Reserve - Securities	\$5 million	271,516.06	4,531,909.93	25,019.47	1.95%
Bank of The West - Recycled Water Cash Flow Reserve - Securities	\$8 million	37,124.41	5,498,092.35	21,559.64	2.05%
<b>Bank of the West Reserve Accounts</b>		<b>1,029,020</b>	<b>29,292,090</b>	<b>137,409</b>	
<b>Total Cash and Investments</b>		<b>40,117,197</b>	<b>29,292,090</b>	<b>137,409</b>	
<b>Restricted</b>					
PARS Irrevocable Trust - Retirement			199,640		-11.15%
PARS Irrevocable Trust - OPEB			390,654		-11.15%
<b>Total PARS Irrevocable Trust (offset liabilities)</b>			<b>590,294</b>		
Bank of The West - Recycled Water SRF Money Market		1,516,395			0.11%
<b>Restricted - Bank of the West Reserve Account</b>		<b>1,516,395</b>			
<b>Cash and Investments</b>		<b>\$ 41,633,591</b>	<b>\$ 29,882,384</b>	<b>\$ 137,409</b>	
<b>Total Cash and Investments</b>		<b>\$ 71,653,384</b>			

**Certification:**

The General Manager/Chief Fiscal Officer and Finance Manager of West Bay Sanitary District represents that the above investments are in accordance with the West Bay Sanitary District Investment Policy, adopted by the District Board on September 14, 2022.

 10/19/2022  
General Manager Date

 10/18/22  
Finance Manager Date

**Report to the District Board for the Regular Meeting of October 26, 2022**



**BANK OF THE WEST**  
**BNP PARIBAS**  
 WEALTH MANAGEMENT

**WBSD - RATE STABILIZATION RESERVE**

Account Number:  
 Statement Period: 07/01/22 - 09/30/22

WEST BAY SANITARY DISTRICT  
 500 LAUREL STREET  
 MENLO PARK CA 94025

**Fiduciary**  
 Chuen Ying Lee  
 (408) 645-3234  
**Portfolio**  
 Michael D. Smith  
 (408) 490-2079

**Asset Allocation**

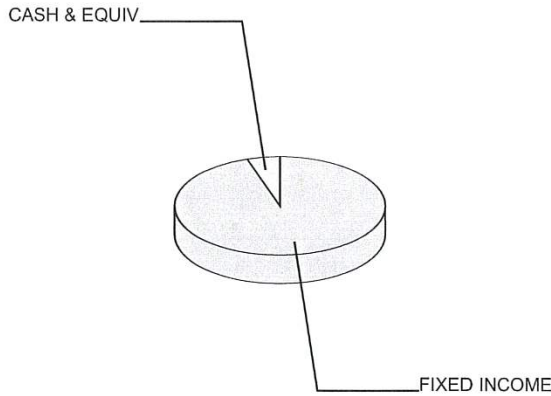

**Asset Valuation**

Description	Market Value	% of Account
Cash & Equiv	432,616.17	4.5%
Fixed Income	9,174,166.59	95.5%
<b>Total Portfolio</b>	<b>\$ 9,606,782.76</b>	<b>100.0%</b>
Accrued Income	49,488.39	
<b>Total Valuation</b>	<b>\$ 9,656,271.15</b>	

**Market Reconciliation**

	Current Period	Year To Date
<b>Beginning Market Value</b>	<b>\$ 9,737,901.10</b>	<b>\$ 9,737,901.10</b>
Income		
Interest.....	54,966.98	54,966.98
Purchased Income.....	-522.28	-522.28
Disbursements.....	-4,205.89	-4,205.89
Realized Gains/(Losses).....	-60.87	-60.87
Change In Accrued Income.....	-2,386.12	-2,386.12
Change In Market Appreciation/(Depreciation).....	-100,292.54	-100,292.54
Non-Cash Asset Changes.....	-29,129.23	-29,129.23
<b>Ending Market Value</b>	<b>\$ 9,656,271.15</b>	<b>\$ 9,656,271.15</b>



**WBSD - RATE STABILIZATION RESERVE**

Account Number:  
 Statement Period:

07/01/22 - 09/30/22

**Asset Position As of 09/30/22**

Asset Description	Units	Market Value Cost	Est. Annual Income Accruals	Current Yield
<b>Cash Equivalents</b>				
Bank of The West Advantage Acct	34,629.940	34,629.94 34,629.94	796.00 239.85	2.30%
US Treasury Bill Due 10/06/2022	400,000.000	397,986.23 398,024.00	0.00 1,933.77	0.00%
<b>Total Cash Equivalents</b>		<b>\$ 432,616.17</b> <b>\$ 432,653.94</b>	<b>796.00</b> <b>2,173.62</b>	<b>0.18%</b>
<b>Fixed Income</b>				
Anz National Intl LTD Fr 3.40% Dtd 03/19/2019 Due 03/19/2024 Non-Callable	210,000.000	205,653.00 218,144.30	7,140.00 237.99	3.47%
American Express Co Sr Gbl 2.50% Dtd 07/30/2019 Due 07/30/2024 Callable	100,000.000	95,776.00 102,842.00	2,500.00 423.61	2.61%
American Tower Corp New Sr Gbl 3.50% Dtd 01/08/2013 Due 01/31/2023 Callable	100,000.000	99,687.00 101,486.00	3,500.00 593.05	3.51%
Apple Inc Sr Gbl Nt 0.75% Dtd 05/11/2020 Due 05/11/2023 Callable	40,000.000	39,200.40 40,162.40	300.00 116.66	0.77%
Apple Inc Sr Gbl 0.70% Dtd 02/08/2021 Due 02/08/2026 Callable	50,000.000	43,979.00 49,948.00	350.00 51.52	0.80%
Asotin Cnty Wash Taxable GO LTD Tax Bds 2021 B Taxable 0.407% Dtd 02/25/2021 Due 12/01/2023 Non-Callable	100,000.000	95,736.00 100,000.00	407.00 135.66	0.43%
BB&T Corp Sr Medium Term Nts Fr 3.70% Dtd 06/05/2018 Due 06/05/2025 Callable	25,000.000	24,133.25 27,110.50	925.00 298.05	3.83%
Bellevue Neb Ctfs Partn Taxable Ref Ctfs Partn Taxable 0.455% Dtd 03/15/2021 Due 09/15/2024 Non-Callable	150,000.000	142,168.50 150,000.00	682.00 30.33	0.48%
Blackrock Inc Sr Nt 3.50% Dtd 03/18/2014 Due 03/18/2024 Callable	210,000.000	206,982.30 219,389.60	7,350.00 265.41	3.55%



**WBSD - RATE STABILIZATION RESERVE**

**Account Number:**  
**Statement Period:**

**07/01/22 - 09/30/22**

**Asset Position As of 09/30/22**

<b>Asset Description</b>	<b>Units</b>	<b>Market Value Cost</b>	<b>Est. Annual Income Accruals</b>	<b>Current Yield</b>
Butte Silver Bow Mont City & C GO Bds 3.00% Dtd 12/28/2016 Due 07/01/2023 Non-Callable	50,000.000	49,945.00 51,259.50	1,500.00 375.00	3.00%
Carolina Beach NC Enterprise S Rev Bds 4.00% Dtd 06/30/2016 Due 06/01/2023 Non-Callable	75,000.000	75,423.00 77,722.75	3,000.00 999.99	3.98%
Chambers Cnty Tex Comb Tax and Rev Ctfs Ob 5.00% Dtd 08/01/2015 Due 03/01/2023 Non-Callable	65,000.000	65,516.10 66,524.90	3,250.00 270.83	4.96%
Charlotte N C Ctfs Partn Taxable Cops 2015a Taxable 2.965% Dtd 05/14/2015 Due 06/01/2023 Callable	155,000.000	153,612.75 158,978.85	4,595.00 1,531.91	2.99%
Colorado Hsg & Fin Auth Taxable Single Family MT 2020 C Taxable 1.928% Dtd 02/20/2020 Due 11/01/2023 Non-Callable	250,000.000	243,040.00 255,365.00	4,820.00 2,008.33	1.98%
Colorado St Brd Governors Univ Rev Ref Bds 2012b 5.00% Dtd 05/01/2012 Due 03/01/2023 Non-Callable	200,000.000	201,588.00 204,072.00	10,000.00 833.33	4.96%
Comcast Corp New Sr Nt 3.375% Dtd 05/27/2015 Due 08/15/2025 Callable	60,000.000	57,593.40 64,496.40	2,025.00 258.75	3.52%
Deere John Capital Corp Fr 3.45% Dtd 03/13/2018 Due 03/13/2025 Non-Callable	110,000.000	106,707.70 117,011.60	3,795.00 189.75	3.56%
Federal Home Loan Bks Cons Bds 0.60% Dtd 04/30/2021 Due 10/30/2024 Callable	250,000.000	230,412.50 250,000.00	1,500.00 629.16	0.65%
Federal Farm Cr Bks Cons Systemwide Bds 0.30% Dtd 01/13/2021 Due 01/13/2025 Callable	200,000.000	181,792.00 199,700.00	600.00 130.00	0.33%
Grant Cnty Wash Pub Util Dist Taxable Sys Ref Bds 2020 Q Taxable 1.877% Dtd 01/29/2020 Due 01/01/2023 Callable	75,000.000	74,675.25 75,571.50	1,407.00 351.93	1.89%
Hamilton Cnty Ohio Sales Tax Sales Tax Bds 2000 B Zero Cpn Dtd 11/09/2000 Due 12/01/2023 Non-Callable	65,000.000	62,411.70 64,682.59	0.00	0.00%





**WBSD - RATE STABILIZATION RESERVE**

Account Number:  
 Statement Period:

07/01/22 - 09/30/22

**Asset Position As of 09/30/22**

Asset Description	Units	Market Value Cost	Est. Annual Income Accruals	Current Yield
Kla Tencor Corp Sr Gbl Nt 4.65% Dtd 11/06/2014 Due 11/01/2024 Callable	150,000.000	149,490.00 162,978.00	6,975.00 2,906.25	4.67%
Laboratory Corp Amer Hldgs Sr Nt 4.00% Dtd 11/01/2013 Due 11/01/2023 Callable	111,000.000	110,179.71 116,131.53	4,440.00 1,849.99	4.03%
League City Tex Combi Tax and Rev Ctfs O 5.00% Dtd 07/01/2017 Due 02/15/2023 Non-Callable	140,000.000	140,967.40 142,608.20	7,000.00 894.44	4.97%
Long Is Pwr Auth N Y Elec Sys Gen Bds 2020 A 5.00% Dtd 08/20/2020 Due 09/01/2023 Non-Callable	45,000.000	45,691.65 47,053.35	2,250.00 187.50	4.92%
Maine Mun Bd Bk Liquor Operati Rev Bds Taxable 4.252% Dtd 09/05/2013 Due 06/01/2023 Callable	100,000.000	99,907.00 103,645.00	4,252.00 1,417.33	4.26%
Nedrose Pub Sch Dist No 4 N D Taxable GO Bldg Ref Bds Taxable 0.35% Dtd 02/17/2021 Due 08/01/2024 Non-Callable	100,000.000	92,692.00 100,041.00	350.00 58.33	0.38%
New York Life Gbl Fdg MTN 144a Sr Sec Gbl 1.10% Dtd 05/07/2020 Due 05/05/2023 Non-Callable	110,000.000	108,038.70 110,797.50	1,210.00 490.72	1.12%
Newark Calif Uni Sch Dist Bds 2002 D Zero Cpn Dtd 04/30/2002 Due 08/01/2023 Non-Callable	75,000.000	72,903.75 74,775.11	0.00	0.00%
Ohio St Common Schs GO Ref Bds 2016 A 5.00% Dtd 03/09/2016 Due 12/15/2023 Non-Callable	45,000.000	46,000.35 47,437.65	2,250.00 662.50	4.89%
Pajaro Valley Calif Uni Sch Di GO Bds 2005 B Zero Cpn Dtd 05/19/2005 Due 08/01/2023 Non-Callable	50,000.000	48,563.00 49,833.56	0.00	0.00%
Paypal Hldgs Inc Sr Gbl 2.40% Dtd 09/26/2019 Due 10/01/2024 Callable	73,000.000	69,733.98 75,838.97	1,752.00 876.00	2.51%
San Francisco Calif Bay Area R Taxable Ref Bds 2019 B Taxable 1.971% Dtd 10/31/2019 Due 07/01/2024 Non-Callable	100,000.000	95,726.00 102,723.00	1,971.00 492.75	2.06%



**WBSD - RATE STABILIZATION RESERVE**

Account Number:  
 Statement Period:

07/01/22 - 09/30/22

**Asset Position As of 09/30/22**

Asset Description	Units	Market Value Cost	Est. Annual Income Accruals	Current Yield
Small Business Admin Gtd Ln Pool Ctfs 2.245% Dtd 09/19/2012 Due 09/10/2022		0.00 0.00	0.00 0.29	0.00%
South Dakota Hsg Dev Auth Taxable Homeownership MT 2021 C Taxable 0.671% Dtd 08/04/2021 Due 05/01/2024 Non-Callable	200,000.000	188,230.00 200,000.00	1,342.00 559.16	0.71%
State Str Corp Sr Sb Nt 3.10% Dtd 05/15/2013 Due 05/15/2023 Non-Callable	200,000.000	198,306.00 205,217.80	6,200.00 2,342.22	3.13%
Tennessee Valley Auth Sr Gbl A Bd 0.75% Dtd 05/11/2020 Due 05/15/2025 Non-Callable	190,000.000	173,198.30 191,627.00	1,425.00 538.33	0.82%
Global Pmts Inc Sr Gbl Nt 4.00% Dtd 05/11/2018 Due 06/01/2023 Callable	75,000.000	74,425.50 77,507.25	3,000.00 999.99	4.03%
Toyota Motor Credit Corp Fr 2.90% Dtd 04/01/2020 Due 03/30/2023 Non-Callable	10,000.000	9,924.60 10,096.20	290.00 0.80	2.92%
Toyota Motor Credit Corp Fr 3.00% Dtd 04/01/2020 Due 04/01/2025 Callable	300,000.000	287,427.00 319,271.90	9,000.00 4,500.00	3.13%
US Treasury Note 0.125% Dtd 09/15/2020 Due 09/15/2023	150,000.000	144,213.00 144,310.55	187.00 8.28	0.13%
US Treasury Note 0.125% Dtd 12/15/2020 Due 12/15/2023	120,000.000	114,206.40 115,120.31	150.00 44.26	0.13%
US Treasury Note 0.75% Dtd 03/31/2021 Due 03/31/2026	240,000.000	213,160.80 238,687.50	1,800.00 4.94	0.84%
US Treasury Note 0.375% Dtd 04/15/2021 Due 04/15/2024	100,000.000	94,168.00 95,281.25	375.00 173.15	0.40%
US Treasury Note 0.375% Dtd 08/15/2021 Due 08/15/2024	80,000.000	74,431.20 75,289.41	300.00 38.31	0.40%
US Treasury Note 1.00% Dtd 12/15/2021 Due 12/15/2024	200,000.000	186,400.00 190,171.88	2,000.00 590.16	1.07%
US Treasury Note 0.75% Dtd 12/31/2021 Due 12/31/2023	100,000.000	95,747.00 96,597.66	750.00 189.53	0.78%



**WBSD - RATE STABILIZATION RESERVE**

Account Number:  
 Statement Period:

07/01/22 - 09/30/22

**Asset Position As of 09/30/22**

Asset Description	Units	Market Value Cost	Est. Annual Income Accruals	Current Yield
US Treasury Note 0.875% Dtd 01/31/2022 Due 01/31/2024	90,000.000	85,988.70 87,816.48	787.00 132.67	0.92%
US Treasury Note 1.625% Dtd 02/15/2016 Due 02/15/2026	200,000.000	183,728.00 190,871.76	3,250.00 415.08	1.77%
US Treasury Note 1.625% Dtd 10/31/2016 Due 10/31/2023	700,000.000	680,421.00 701,023.83	11,375.00 4,760.19	1.67%
US Treasury Note 2.50% Dtd 05/15/2014 Due 05/15/2024	80,000.000	77,725.60 79,621.87	2,000.00 755.43	2.57%
US Treasury Note 2.00% Dtd 06/30/2017 Due 06/30/2024	120,000.000	115,416.00 117,487.50	2,400.00 606.52	2.08%
US Treasury Note 2.625% Dtd 02/28/2018 Due 02/28/2023	600,000.000	597,366.00 604,291.55	15,750.00 1,348.75	2.64%
US Treasury Note 2.625% Dtd 06/30/2018 Due 06/30/2023	650,000.000	642,993.00 658,093.92	17,062.00 4,311.99	2.65%
US Treasury Note 2.50% Dtd 01/31/2019 Due 01/31/2024	200,000.000	195,298.00 199,508.82	5,000.00 842.39	2.56%
US Treasury Note 2.375% Dtd 02/28/2019 Due 02/29/2024	550,000.000	535,562.50 556,309.16	13,062.00 1,118.61	2.44%
University Calif Revs Gen Rev Bds 2015 A Taxable 2.909% Dtd 03/25/2015 Due 05/15/2023 Callable	160,000.000	158,681.60 162,767.30	4,654.00 1,758.32	2.93%
Waco Tex Indpt Sch Dist Taxable Unltd Tax Ref Bd Taxable Zero Cpn Dtd 01/01/2021 Due 08/15/2024 Non-Callable	300,000.000	274,911.00 296,938.68	0.00	0.00%
Waco Tex Indpt Sch Dist Taxable Unltd Tax Ref Bd Taxable Zero Cpn Dtd 01/01/2021 Due 08/15/2025 Non-Callable	150,000.000	130,392.00 146,916.26	0.00	0.00%
West Hollywood Calif Pub Fing Rev Bds 5.00% Dtd 06/30/2016 Due 04/01/2023 Non-Callable	55,000.000	55,522.50 57,524.35	2,750.00 1,375.00	4.95%
William S Hart Calif Un High S GO Bds 2013 C 4.00% Dtd 02/21/2013 Due 08/01/2023 Non-Callable	50,000.000	50,396.50 51,795.00	2,000.00 333.33	3.97%



**WBSD - RATE STABILIZATION RESERVE**

Account Number:  
 Statement Period:

07/01/22 - 09/30/22

**Asset Position As of 09/30/22**

Asset Description	Units	Market Value Cost	Est. Annual Income Accruals	Current Yield
<b>Total Fixed Income</b>		\$ 9,174,166.59 \$ 9,598,475.95	199,005.00 47,314.77	2.17%
<b>Cash</b>				
Principal Cash		0.00 0.00	0.00	0.00%
Income Cash		0.00 0.00	0.00	0.00%
<b>Total Cash</b>		\$ 0.00 \$ 0.00	0.00 0.00	0.00%
<b>Total Market Value</b>		\$ 9,606,782.76 \$ 10,031,129.89	199,801.00 49,488.39	2.08%
<b>Total Market Value Plus Accruals</b>		\$ 9,656,271.15		

**Income Activity**

	Date	Income Cash	Principal Cash
<b>Interest Income</b>			
Bank of The West Advantage Acct			
Int To 06/30/22	07/01/22		137.07
Int To 07/31/22	08/01/22		250.43
Int To 08/31/22	09/01/22		231.51
Anz National Intl LTD Fr			
3.40% Dtd 03/19/2019 Due 03/19/2024			
Non-Callable			
Int To 09/19/22 on 210,000	09/19/22		3,570.00
Alabama St GO Ref Bds 2014 A			
5.00% Dtd 08/06/2014 Due 08/01/2022			
Non-Callable			
Int To 08/01/22 on 80,000	08/01/22		2,000.00
American Express Co Sr Gbl			
2.50% Dtd 07/30/2019 Due 07/30/2024			
Callable			
Int To 07/30/22 on 100,000	08/01/22		1,250.00
American Tower Corp New Sr Gbl			
3.50% Dtd 01/08/2013 Due 01/31/2023			
Callable			
Int To 07/31/22 on 100,000	08/01/22		1,750.00



**WBSD - RATE STABILIZATION RESERVE**

Account Number:  
 Statement Period:

07/01/22 - 09/30/22

Income Activity			
	Date	Income Cash	Principal Cash
Apple Inc Sr Gbl 0.70% Dtd 02/08/2021 Due 02/08/2026 Callable Int To 08/08/22 on 50,000	08/08/22		175.00
Bellevue Neb Ctfs Partn Taxable Ref Ctfs Partn Taxable 0.455% Dtd 03/15/2021 Due 09/15/2024 Non-Callable Int To 09/15/22 on 150,000	09/15/22		341.25
Blackrock Inc Sr Nt 3.50% Dtd 03/18/2014 Due 03/18/2024 Callable Int To 09/18/22 on 210,000	09/19/22		3,675.00
Butte Silver Bow Mont City & C GO Bds 3.00% Dtd 12/28/2016 Due 07/01/2023 Non-Callable Int To 07/01/22 on 50,000	07/01/22		750.00
Chambers Cnty Tex Comb Tax and Rev Ctfs Ob 5.00% Dtd 08/01/2015 Due 03/01/2023 Non-Callable Int To 09/01/22 on 65,000	09/01/22		1,625.00
Colorado St Brd Governors Univ Rev Ref Bds 2012b 5.00% Dtd 05/01/2012 Due 03/01/2023 Non-Callable Int To 09/01/22 on 200,000	09/01/22		5,000.00
Comcast Corp New Sr Nt 3.375% Dtd 05/27/2015 Due 08/15/2025 Callable Int To 08/15/22 on 60,000	08/15/22		1,012.50
Deere John Capital Corp Fr 3.45% Dtd 03/13/2018 Due 03/13/2025 Non-Callable Int To 09/13/22 on 110,000	09/13/22		1,897.50
Disney Walt Co Sr Gbl Nt 1.65% Dtd 09/06/2019 Due 09/01/2022 Callable Int To 09/01/22 on 35,000	09/01/22		288.75
Federal Farm Cr Bks Cons Systemwide Bds 1.90% Dtd 07/19/2017 Due 07/19/2022 Non-Callable Int To 07/19/22 on 80,000	07/19/22		760.00



**WBSD - RATE STABILIZATION RESERVE**

Account Number:  
 Statement Period:

07/01/22 - 09/30/22

Income Activity			
	Date	Income Cash	Principal Cash
Federal Farm Cr Bks Cons Systemwide Bds 1.90% Dtd 08/03/2017 Due 08/03/2022 Non-Callable Int To 08/03/22 on 85,000	08/03/22		807.50
Federal Farm Cr Bks Cons Systemwide Bds 0.30% Dtd 01/13/2021 Due 01/13/2025 Callable Int To 07/13/22 on 200,000	07/13/22		300.00
Grant Cnty Wash Pub Util Dist Taxable Sys Ref Bds 2020 Q Taxable 1.877% Dtd 01/29/2020 Due 01/01/2023 Callable Int To 07/01/22 on 75,000	07/01/22		703.87
LA Canada Calif Uni Sch Dist Taxable GO Ref Bds Taxable 1.55% Dtd 04/28/2020 Due 08/01/2022 Non-Callable Int To 08/01/22 on 30,000	08/01/22		232.50
League City Tex Combi Tax and Rev Ctfs O 5.00% Dtd 07/01/2017 Due 02/15/2023 Non-Callable Int To 08/15/22 on 140,000	08/15/22		3,500.00
Long Is Pwr Auth N Y Elec Sys Gen Bds 2020 A 5.00% Dtd 08/20/2020 Due 09/01/2023 Non-Callable Int To 09/01/22 on 45,000	09/01/22		1,125.00
Nedrose Pub Sch Dist No 4 N D Taxable GO Bldg Ref Bds Taxable 0.35% Dtd 02/17/2021 Due 08/01/2024 Non-Callable Int To 08/01/22 on 100,000	08/01/22		175.00
San Francisco Calif Bay Area R Taxable Ref Bds 2019 B Taxable 1.971% Dtd 10/31/2019 Due 07/01/2024 Non-Callable Int To 07/01/22 on 100,000	07/01/22		985.50
Small Business Admin Gtd Ln Pool Ctfs 2.245% Dtd 09/19/2012 Due 09/10/2022 Int To 09/10/22 on 4736.64	09/12/22		53.60



**WBSD - RATE STABILIZATION RESERVE**

Account Number:  
 Statement Period:

07/01/22 - 09/30/22

Income Activity			
	Date	Income Cash	Principal Cash
Toyota Motor Credit Corp Fr 2.90% Dtd 04/01/2020 Due 03/30/2023 Non-Callable Int To 09/30/22 on 10,000	09/30/22		145.00
US Treasury Note 0.75% Dtd 03/31/2021 Due 03/31/2026 Int To 09/30/22 on 240,000	09/30/22		900.00
US Treasury Note 0.375% Dtd 08/15/2021 Due 08/15/2024 Int To 08/15/22 on 80,000	08/15/22		150.00
US Treasury Note 0.875% Dtd 01/31/2022 Due 01/31/2024 Int 01/31/22 To 07/31/22 on 90000	08/01/22		393.75
US Treasury Note 1.625% Dtd 02/15/2016 Due 02/15/2026 Int To 08/15/22 on 200,000	08/15/22		1,625.00
US Treasury Note 2.625% Dtd 02/28/2018 Due 02/28/2023 Int To 08/31/22 on 600,000	08/31/22		7,875.00
US Treasury Note 2.50% Dtd 01/31/2019 Due 01/31/2024 Int To 07/31/22 on 200,000	08/01/22		2,500.00
US Treasury Note 2.375% Dtd 02/28/2019 Due 02/29/2024 Int To 08/31/22 on 550,000	08/31/22		6,531.25
Washington Fed Hwy Grnt Antic Grnt Antic Rev Bds 2012f 5.00% Dtd 06/06/2012 Due 09/01/2023 Prerefunded 09/01/2022 @ 100 Callable Int To 09/01/22 on 50,000	09/01/22		1,250.00
William S Hart Calif Un High S GO Bds 2013 C 4.00% Dtd 02/21/2013 Due 08/01/2023 Non-Callable Int To 08/01/22 on 50,000	08/01/22		1,000.00
<b>Total Interest Income</b>		<b>\$ 0.00</b>	<b>\$ 54,966.98</b>



**WBSD - RATE STABILIZATION RESERVE**

Account Number:  
 Statement Period:

07/01/22 - 09/30/22

Income Activity			
	Date	Income Cash	Principal Cash
<b>Purchased Income</b>			
US Treasury Note 0.125% Dtd 09/15/2020 Due 09/15/2023 Accrued Int To 09/23/22 Paid on Purchase of 150,000	09/23/22		-4.14
US Treasury Note 0.125% Dtd 12/15/2020 Due 12/15/2023 Accrued Int To 08/11/22 Paid on Purchase of 120,000	08/11/22		-23.36
US Treasury Note 0.375% Dtd 04/15/2021 Due 04/15/2024 Accrued Int To 07/11/22 Paid on Purchase of 100,000	07/11/22		-89.14
US Treasury Note 1.00% Dtd 12/15/2021 Due 12/15/2024 Accrued Int To 08/11/22 Paid on Purchase of 200,000	08/11/22		-311.48
US Treasury Note 0.75% Dtd 12/31/2021 Due 12/31/2023 Accrued Int To 07/11/22 Paid on Purchase of 100,000	07/11/22		-22.42
US Treasury Note 2.00% Dtd 06/30/2017 Due 06/30/2024 Accrued Int To 07/11/22 Paid on Purchase of 120,000	07/11/22		-71.74
<b>Total Purchased Income</b>		<b>\$ 0.00</b>	<b>\$ -522.28</b>
<b>Total Income</b>		<b>\$ 0.00</b>	<b>\$ 54,444.70</b>

Disbursement Activity			
	Date	Income Cash	Principal Cash
<b>Fees/Expenses</b>			
Monthly Fee To 06/30/22	07/15/22		-1,423.13
Monthly Fee To 07/31/22	08/15/22		-1,393.25
Monthly Fee To 08/31/22	09/15/22		-1,389.51
<b>Total Fees/Expenses</b>		<b>\$ 0.00</b>	<b>\$ -4,205.89</b>
<b>Total Disbursements</b>		<b>\$ 0.00</b>	<b>\$ -4,205.89</b>





**WBSD - RATE STABILIZATION RESERVE**

Account Number:  
 Statement Period:

07/01/22 - 09/30/22

Purchase Activity			
	Date	Income Cash	Principal Cash
Bank of The West Advantage Acct Purchases (14) 07/01/22 To 09/30/22	09/30/22		-419,703.62
US Treasury Note 0.125% Dtd 09/15/2020 Due 09/15/2023 Purchased 150000 09/22/22 From First Tennessee Bank NA Bond Di @ 96.207031	09/23/22		-144,310.55
US Treasury Note 0.125% Dtd 12/15/2020 Due 12/15/2023 Purchased 120000 08/10/22 From Wells Fargo Securities, LLC @ 95.933593	08/11/22		-115,120.31
US Treasury Note 0.375% Dtd 04/15/2021 Due 04/15/2024 Purchased 100000 07/08/22 From Wells Fargo Securities, LLC @ 95.28125	07/11/22		-95,281.25
US Treasury Note 1.00% Dtd 12/15/2021 Due 12/15/2024 Purchased 200000 08/10/22 From Morgan Stanley & Co @ 95.085938	08/11/22		-190,171.88
US Treasury Note 0.75% Dtd 12/31/2021 Due 12/31/2023 Purchased 100000 07/08/22 From Wells Fargo Securities, LLC @ 96.597656	07/11/22		-96,597.66
US Treasury Note 2.00% Dtd 06/30/2017 Due 06/30/2024 Purchased 120000 07/08/22 From Wells Fargo Securities, LLC @ 97.90625	07/11/22		-117,487.50
<b>Total Purchases</b>		<b>\$ 0.00</b>	<b>\$ -1,178,672.77</b>



**WBSD - RATE STABILIZATION RESERVE**

Account Number:  
 Statement Period:

07/01/22 - 09/30/22

Sale Activity			
	Date	Proceeds	Realized Gain/Loss
Bank of The West Advantage Acct Sales (6) 07/01/22 To 09/30/22	09/30/22	763,697.32	
Alabama St GO Ref Bds 2014 A 5.00% Dtd 08/06/2014 Due 08/01/2022 Non-Callable Recd Proceeds on Maturity of 80,000 Par Value	08/01/22	80,000.00	
Disney Walt Co Sr Gbl Nt 1.65% Dtd 09/06/2019 Due 09/01/2022 Callable Recd Proceeds on Maturity of 35,000 Par Value	09/01/22	35,000.00	
Federal Farm Cr Bks Cons Systemwide Bds 1.90% Dtd 07/19/2017 Due 07/19/2022 Non-Callable Recd Proceeds on Maturity of 80,000 Par Value	07/19/22	80,000.00	
Federal Farm Cr Bks Cons Systemwide Bds 1.90% Dtd 08/03/2017 Due 08/03/2022 Non-Callable Recd Proceeds on Maturity of 85,000 Par Value	08/03/22	85,000.00	
LA Canada Calif Uni Sch Dist Taxable GO Ref Bds Taxable 1.55% Dtd 04/28/2020 Due 08/01/2022 Non-Callable Recd Proceeds on Maturity of 30,000 Par Value	08/01/22	30,000.00	
Small Business Admin Gtd Ln Pool Ctfs 2.245% Dtd 09/19/2012 Due 09/10/2022 Recd Proceeds on Maturity of 4,736.640 Par Value	09/12/22	4,736.64	-60.87
Washington Fed Hwy Grnt Antic Grnt Antic Rev Bds 2012f 5.00% Dtd 06/06/2012 Due 09/01/2023 Prerefunded 09/01/2022 @ 100 Callable Recd Proceeds on Pre-Refund of 50,000 Par Value	09/01/22	50,000.00	
<b>Total Sales</b>		<b>\$ 1,128,433.96</b>	<b>\$ -60.87</b>



**WBSD - RATE STABILIZATION RESERVE**

Account Number:  
 Statement Period:

07/01/22 - 09/30/22

Non-Cash Activity		
	Date	Cost
Anz National Intl LTD Fr 3.40% Dtd 03/19/2019 Due 03/19/2024 Non-Callable		
Amortization of Premium	09/19/22	-1,409.10
Amortization of Premium	09/19/22	-1,284.00
Alabama St GO Ref Bds 2014 A 5.00% Dtd 08/06/2014 Due 08/01/2022 Non-Callable		
Amortization of Premium	08/01/22	-1,450.50
Amortization of Premium	08/01/22	-117.85
American Express Co Sr Glbl 2.50% Dtd 07/30/2019 Due 07/30/2024 Callable		
Amortization of Premium	07/29/22	-701.00
American Tower Corp New Sr Glbl 3.50% Dtd 01/08/2013 Due 01/31/2023 Callable		
Amortization of Premium	07/29/22	-1,482.00
Blackrock Inc Sr Nt 3.50% Dtd 03/18/2014 Due 03/18/2024 Callable		
Amortization of Premium	09/16/22	-1,630.20
Amortization of Premium	09/16/22	-1,485.00
Butte Silver Bow Mont City & C GO Bds 3.00% Dtd 12/28/2016 Due 07/01/2023 Non-Callable		
Amortization of Premium	07/01/22	-627.50
Chambers Cnty Tex Comb Tax and Rev Ctfs Ob 5.00% Dtd 08/01/2015 Due 03/01/2023 Non-Callable		
Amortization of Premium	09/01/22	-1,522.95
Colorado St Brd Governors Univ Rev Ref Bds 2012b 5.00% Dtd 05/01/2012 Due 03/01/2023 Non-Callable		
Amortization of Premium	09/01/22	-2,282.50
Amortization of Premium	09/01/22	-1,773.00
Comcast Corp New Sr Nt 3.375% Dtd 05/27/2015 Due 08/15/2025 Callable		
Amortization of Premium	08/15/22	-738.60



**WBSD - RATE STABILIZATION RESERVE**

Account Number:  
 Statement Period:

07/01/22 - 09/30/22

Non-Cash Activity		
	Date	Cost
Deere John Capital Corp Fr 3.45% Dtd 03/13/2018 Due 03/13/2025 Non-Callable Amortization of Premium	09/13/22	-553.50
Amortization of Premium	09/13/22	-831.00
Disney Walt Co Sr Gbl Nt 1.65% Dtd 09/06/2019 Due 09/01/2022 Callable Amortization of Premium	09/01/22	-167.30
Federal Farm Cr Bks Cons Systemwide Bds 1.90% Dtd 07/19/2017 Due 07/19/2022 Non-Callable Amortization of Premium	07/19/22	-39.20
Federal Farm Cr Bks Cons Systemwide Bds 1.90% Dtd 08/03/2017 Due 08/03/2022 Non-Callable Amortization of Premium	08/03/22	-22.95
Grant Cnty Wash Pub Util Dist Taxable Sys Ref Bds 2020 Q Taxable 1.877% Dtd 01/29/2020 Due 01/01/2023 Callable Amortization of Premium	07/01/22	-571.50
Hamilton Cnty Ohio Sales Tax Sales Tax Bds 2000 B Zero Cpn Dtd 11/09/2000 Due 12/01/2023 Non-Callable Accretion of Discount	07/29/22	22.60
Accretion of Discount	08/31/22	22.60
Accretion of Discount	09/30/22	22.60
League City Tex Combi Tax and Rev Ctfs O 5.00% Dtd 07/01/2017 Due 02/15/2023 Non-Callable Amortization of Premium	08/15/22	-2,592.80
Long Is Pwr Auth N Y Elec Sys Gen Bds 2020 A 5.00% Dtd 08/20/2020 Due 09/01/2023 Non-Callable Amortization of Premium	09/01/22	-1,023.75
Nedrose Pub Sch Dist No 4 N D Taxable GO Bldg Ref Bds Taxable 0.35% Dtd 02/17/2021 Due 08/01/2024 Non-Callable Amortization of Premium	08/01/22	-11.00



**WBSD - RATE STABILIZATION RESERVE**

Account Number:  
 Statement Period:

07/01/22 - 09/30/22

Non-Cash Activity		
	Date	Cost
Newark Calif Uni Sch Dist Bds 2002 D Zero Cpn Dtd 04/30/2002 Due 08/01/2023 Non-Callable		
Accretion of Discount	07/29/22	22.39
Accretion of Discount	08/31/22	22.39
Accretion of Discount	09/30/22	22.39
Pajaro Valley Calif Uni Sch Di GO Bds 2005 B Zero Cpn Dtd 05/19/2005 Due 08/01/2023 Non-Callable		
Accretion of Discount	07/29/22	16.57
Accretion of Discount	08/31/22	16.57
Accretion of Discount	09/30/22	16.57
San Francisco Calif Bay Area R Taxable Ref Bds 2019 B Taxable 1.971% Dtd 10/31/2019 Due 07/01/2024 Non-Callable		
Amortization of Premium	07/01/22	-676.00
Toyota Motor Credit Corp Fr 2.90% Dtd 04/01/2020 Due 03/30/2023 Non-Callable		
Amortization of Premium	09/30/22	-95.90
US Treasury Note 0.375% Dtd 08/15/2021 Due 08/15/2024		
Accretion of Discount	08/15/22	392.54
US Treasury Note 0.875% Dtd 01/31/2022 Due 01/31/2024		
Accretion of Discount	07/29/22	266.87
US Treasury Note 1.625% Dtd 02/15/2016 Due 02/15/2026		
Accretion of Discount	08/15/22	738.95
US Treasury Note 2.625% Dtd 02/28/2018 Due 02/28/2023		
Amortization of Premium	08/31/22	-4,266.26
US Treasury Note 2.50% Dtd 01/31/2019 Due 01/31/2024		
Accretion of Discount	07/29/22	79.13
US Treasury Note 2.375% Dtd 02/28/2019 Due 02/29/2024		
Amortization of Premium	08/31/22	-2,069.80



**WBSD - RATE STABILIZATION RESERVE**

Account Number:  
 Statement Period:

07/01/22 - 09/30/22

Non-Cash Activity		
	Date	Cost
Waco Tex Indpt Sch Dist Taxable		
Unltd Tax Ref Bd Taxable Zero Cpn		
Dtd 01/01/2021 Due 08/15/2024		
Non-Callable		
Accretion of Discount	07/29/22	68.02
Accretion of Discount	07/29/22	68.02
Accretion of Discount	08/31/22	68.02
Accretion of Discount	08/31/22	68.02
Accretion of Discount	09/30/22	68.02
Accretion of Discount	09/30/22	68.02
Waco Tex Indpt Sch Dist Taxable		
Unltd Tax Ref Bd Taxable Zero Cpn		
Dtd 01/01/2021 Due 08/15/2025		
Non-Callable		
Accretion of Discount	07/29/22	89.38
Accretion of Discount	08/31/22	89.38
Accretion of Discount	09/30/22	89.38
Washington Fed Hwy Grnt Antic Grnt		
Antic Rev Bds 2012f 5.00% Dtd		
06/06/2012 Due 09/01/2023		
Prerefunded 09/01/2022 @ 100		
Callable		
Amortization of Premium	09/01/22	-1,147.50
William S Hart Calif Un High S GO		
Bds 2013 C 4.00% Dtd 02/21/2013 Due		
08/01/2023 Non-Callable		
Amortization of Premium	08/01/22	-895.00
<b>Total Non-Cash Transactions</b>		<b>\$ -29,129.23</b>

SECURITY PRICES CONTAINED IN THIS STATEMENT ARE OBTAINED FROM THE MOST RELIABLE SOURCES AVAILABLE BUT ARE NOT GUARANTEED BY BANK OF THE WEST. QUOTED PRICES MAY NOT EQUAL ACTUAL PRICES BECAUSE OF SECURITY SIZE, MARKET PRICE, TERM AND DEMAND.



**BANK OF THE WEST**  
**BNP PARIBAS**  
WEALTH MANAGEMENT

### **Electronic Funds Transfers**

#### **Preauthorized Transfers:**

You may request an electronic fund transfer (EFT), such as an ACH transfer from or deposit to your account, by contacting your account Administrator. You may also preauthorize periodic EFTs by contacting your account Administrator. If you would like to know whether a preauthorized EFT has occurred, please contact your account Administrator at the phone number listed on the first page of your statement. TTY 1-866-936-2689, Monday - Friday, 8 a.m. - 4:30 p.m. Central Time.

#### **Error Resolution Notice:**

If you think a statement or receipt is wrong or if you need more information about an EFT listed on a statement or receipt, telephone your account Administrator at the phone number listed on the first page of your statement, TTY 1-866-936-2689, Monday - Friday, 8 a.m. - 4:30 p.m. Central Time, write to us at Bank of the West, GIFS Operations, 12000 North Washington Street, Suite, 300, Thornton, CO 80241 or e-mail us at [WMGGIFSOperations@bankofthewest.com](mailto:WMGGIFSOperations@bankofthewest.com) as soon as possible. We must hear from you no later than 60 days after we sent the FIRST statement on which the problem or error appeared.

1. Tell us your name and account number (if any).
2. Tell us the dollar amount of the suspected error.
3. Describe the error or the transfer you are unsure about, and explain as clearly as you can why you believe it is an error or why you need more information.

If you contact us verbally, we may require that you send us your complaint or question in writing within 10 business days. We will investigate your complaint and will correct any error promptly. If we take more than 10 business days to do this, we will credit your account for the amount you think is in error, so that you will have the use of the money during the time it takes us to complete our investigation.



**WBSD - TREATMENT PLANT RESERVE**

Account Number:  
 Statement Period: 07/01/22 - 09/30/22

WEST BAY SANITARY DISTRICT  
 500 LAUREL STREET  
 MENLO PARK CA 94025

**Fiduciary**  
 Chuen Ying Lee  
 (408) 645-3234  
**Portfolio**  
 Michael D. Smith  
 (408) 490-2079

**Asset Allocation**

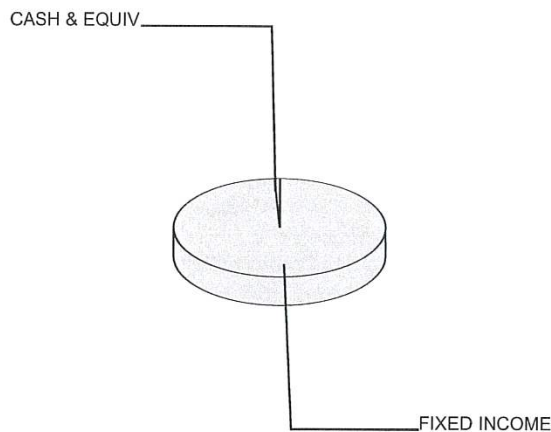

**Asset Valuation**

Description	Market Value	% of Account
Cash & Equiv	15,152.59	0.3%
Fixed Income	4,610,580.70	99.7%
<b>Total Portfolio</b>	<b>\$ 4,625,733.29</b>	<b>100.0%</b>
Accrued Income	16,496.26	
<b>Total Valuation</b>	<b>\$ 4,642,229.55</b>	

**Market Reconciliation**

	Current Period	Year To Date
<b>Beginning Market Value</b>	<b>\$ 2,493,136.18</b>	<b>\$ 2,493,136.18</b>
Income		
Interest.....	14,006.19	14,006.19
Purchased Income.....	-2,722.97	-2,722.97
Additions.....	2,202,111.08	2,202,111.08
Disbursements.....	-1,708.47	-1,708.47
Realized Gains/(Losses).....	0.00	0.00
Change In Accrued Income.....	6,306.54	6,306.54
Change In Market Appreciation/(Depreciation).....	-72,500.05	-72,500.05
Non-Cash Asset Changes.....	3,601.05	3,601.05
<b>Ending Market Value</b>	<b>\$ 4,642,229.55</b>	<b>\$ 4,642,229.55</b>





**WBSD - TREATMENT PLANT RESERVE**

Account Number:  
Statement Period:

07/01/22 - 09/30/22

**Asset Position As of 09/30/22**

Asset Description	Units	Market Value Cost	Est. Annual Income Accruals	Current Yield
<b>Cash Equivalents</b>				
Bank of The West Advantage Acct	15,152.590	15,152.59 15,152.59	348.00 38.67	2.30%
<b>Total Cash Equivalents</b>		<b>\$ 15,152.59</b> <b>\$ 15,152.59</b>	<b>348.00</b> <b>38.67</b>	<b>2.30%</b>
<b>Fixed Income</b>				
US Treasury Note 0.125% Dtd 09/15/2020 Due 09/15/2023	20,000.000	19,228.40 19,241.41	25.00 1.10	0.13%
US Treasury Note 0.125% Dtd 12/15/2020 Due 12/15/2023	40,000.000	38,068.80 38,373.44	50.00 14.75	0.13%
US Treasury Note 0.375% Dtd 04/15/2021 Due 04/15/2024	500,000.000	470,840.00 476,406.25	1,875.00 865.78	0.40%
US Treasury Note 0.50% Dtd 11/30/2021 Due 11/30/2023	400,000.000	382,908.00 385,953.13	2,000.00 672.12	0.52%
US Treasury Note 1.00% Dtd 12/15/2021 Due 12/15/2024	40,000.000	37,280.00 38,034.38	400.00 118.03	1.07%
US Treasury Note 0.75% Dtd 12/31/2021 Due 12/31/2023	300,000.000	287,241.00 289,792.97	2,250.00 568.61	0.78%
US Treasury Note 0.875% Dtd 01/31/2022 Due 01/31/2024	1,150,000.000	1,098,744.50 1,118,657.21	10,062.00 1,695.31	0.92%
US Treasury Note 2.25% Dtd 03/31/2022 Due 03/31/2024	750,000.000	727,620.00 746,080.54	16,875.00 46.35	2.32%
US Treasury Note 2.50% Dtd 05/15/2014 Due 05/15/2024	1,000,000.000	971,570.00 997,851.56	25,000.00 9,442.93	2.57%
US Treasury Note 2.00% Dtd 06/30/2017 Due 06/30/2024	600,000.000	577,080.00 587,437.50	12,000.00 3,032.61	2.08%
<b>Total Fixed Income</b>		<b>\$ 4,610,580.70</b> <b>\$ 4,697,828.39</b>	<b>70,537.00</b> <b>16,457.59</b>	<b>1.53%</b>
<b>Cash</b>				
Principal Cash		0.00 0.00	0.00	0.00%



**WBSD - TREATMENT PLANT RESERVE**

Account Number:  
 Statement Period:

07/01/22 - 09/30/22

**Asset Position As of 09/30/22**

Asset Description	Units	Market Value Cost	Est. Annual Income Accruals	Current Yield
Income Cash		0.00 0.00	0.00	0.00%
<b>Total Cash</b>		<b>\$ 0.00</b> <b>\$ 0.00</b>	<b>0.00</b> <b>0.00</b>	<b>0.00%</b>
<b>Total Market Value</b>		<b>\$ 4,625,733.29</b> <b>\$ 4,712,980.98</b>	<b>70,885.00</b> <b>16,496.26</b>	<b>1.53%</b>
<b>Total Market Value Plus Accruals</b>		<b>\$ 4,642,229.55</b>		

**Income Activity**

	Date	Income Cash	Principal Cash
<b>Interest Income</b>			
Bank of The West Advantage Acct			
Int To 06/30/22	07/01/22		17.61
Int To 07/31/22	08/01/22		437.49
Int To 08/31/22	09/01/22		82.34
US Treasury Note			
0.875% Dtd 01/31/2022 Due 01/31/2024			
Int 01/31/22 To 07/31/22 on 1150000	08/01/22		5,031.25
US Treasury Note			
2.25% Dtd 03/31/2022 Due 03/31/2024			
Int 03/31/22 To 09/30/22 on 750000	09/30/22		8,437.50
<b>Total Interest Income</b>		<b>\$ 0.00</b>	<b>\$ 14,006.19</b>
<b>Purchased Income</b>			
US Treasury Note			
0.125% Dtd 09/15/2020 Due 09/15/2023			
Accrued Int To 09/23/22 Paid on	09/23/22		-0.55
Purchase of 20,000			
US Treasury Note			
0.125% Dtd 12/15/2020 Due 12/15/2023			
Accrued Int To 08/11/22 Paid on	08/11/22		-7.79
Purchase of 40,000			
US Treasury Note			
0.375% Dtd 04/15/2021 Due 04/15/2024			
Accrued Int To 07/11/22 Paid on	07/11/22		-445.70
Purchase of 500,000			



**WBSD - TREATMENT PLANT RESERVE**

Account Number:  
 Statement Period: 07/01/22 - 09/30/22

Income Activity			
	Date	Income Cash	Principal Cash
US Treasury Note 0.50% Dtd 11/30/2021 Due 11/30/2023 Accrued Int To 07/11/22 Paid on Purchase of 400,000	07/11/22		-224.04
US Treasury Note 1.00% Dtd 12/15/2021 Due 12/15/2024 Accrued Int To 08/11/22 Paid on Purchase of 40,000	08/11/22		-62.30
US Treasury Note 0.75% Dtd 12/31/2021 Due 12/31/2023 Accrued Int To 07/11/22 Paid on Purchase of 300,000	07/11/22		-67.26
US Treasury Note 0.875% Dtd 01/31/2022 Due 01/31/2024 Accrued Int To 07/11/22 Paid on Purchase of 400,000	07/11/22		-1,556.63
US Treasury Note 2.00% Dtd 06/30/2017 Due 06/30/2024 Accrued Int To 07/11/22 Paid on Purchase of 600,000	07/11/22		-358.70
<b>Total Purchased Income</b>		<b>\$ 0.00</b>	<b>\$ -2,722.97</b>
<b>Total Income</b>		<b>\$ 0.00</b>	<b>\$ 11,283.22</b>

Additions			
	Date	Income Cash	Principal Cash
<b>Miscellaneous Additions</b>			
Addition To Account ACH Transfer From Botw Ckg Ending In 6049 Per Client Instructions:7.7.22	07/07/22		2,202,111.08
<b>Total Miscellaneous Additions</b>		<b>\$ 0.00</b>	<b>\$ 2,202,111.08</b>
<b>Total Additions</b>		<b>\$ 0.00</b>	<b>\$ 2,202,111.08</b>



**WBSD - TREATMENT PLANT RESERVE**

Account Number:  
 Statement Period: 07/01/22 - 09/30/22

Disbursement Activity			
	Date	Income Cash	Principal Cash
<b>Fees/Expenses</b>			
Monthly Fee To 06/30/22	07/15/22		-364.81
Monthly Fee To 07/31/22	08/15/22		-673.36
Monthly Fee To 08/31/22	09/15/22		-670.30
<b>Total Fees/Expenses</b>		<b>\$ 0.00</b>	<b>\$ -1,708.47</b>
<b>Total Disbursements</b>		<b>\$ 0.00</b>	<b>\$ -1,708.47</b>

Purchase Activity			
	Date	Income Cash	Principal Cash
Bank of The West Advantage Acct Purchases (5) 07/01/22 To 09/30/22	09/30/22		-2,216,117.27
US Treasury Note 0.125% Dtd 09/15/2020 Due 09/15/2023 Purchased 20000 09/22/22 From First Tennessee Bank NA Bond Di @ 96.207031	09/23/22		-19,241.41
US Treasury Note 0.125% Dtd 12/15/2020 Due 12/15/2023 Purchased 40000 08/10/22 From Wells Fargo Securities, LLC @ 95.933593	08/11/22		-38,373.44
US Treasury Note 0.375% Dtd 04/15/2021 Due 04/15/2024 Purchased 500000 07/08/22 From Wells Fargo Securities, LLC @ 95.28125	07/11/22		-476,406.25
US Treasury Note 0.50% Dtd 11/30/2021 Due 11/30/2023 Purchased 400000 07/08/22 From Wells Fargo Securities, LLC @ 96.488281	07/11/22		-385,953.13
US Treasury Note 1.00% Dtd 12/15/2021 Due 12/15/2024 Purchased 40000 08/10/22 From Morgan Stanley & Co @ 95.085938	08/11/22		-38,034.38



**WBSD - TREATMENT PLANT RESERVE**

Account Number:  
 Statement Period:

07/01/22 - 09/30/22

Purchase Activity			
	Date	Income Cash	Principal Cash
US Treasury Note 0.75% Dtd 12/31/2021 Due 12/31/2023 Purchased 300000 07/08/22 From Wells Fargo Securities, LLC @ 96.597656	07/11/22		-289,792.97
US Treasury Note 0.875% Dtd 01/31/2022 Due 01/31/2024 Purchased 400000 07/08/22 From Wells Fargo Securities, LLC @ 96.597656	07/11/22		-386,390.62
US Treasury Note 2.00% Dtd 06/30/2017 Due 06/30/2024 Purchased 600000 07/08/22 From Wells Fargo Securities, LLC @ 97.90625	07/11/22		-587,437.50
<b>Total Purchases</b>		<b>\$ 0.00</b>	<b>\$ -4,437,746.97</b>

Sale Activity			
	Date	Proceeds	Realized Gain/Loss
Bank of The West Advantage Acct Sales (6) 07/01/22 To 09/30/22	09/30/22	2,226,061.14	
<b>Total Sales</b>		<b>\$ 2,226,061.14</b>	<b>\$ 0.00</b>

Non-Cash Activity			
	Date	Cost	
US Treasury Note 0.875% Dtd 01/31/2022 Due 01/31/2024 Accretion of Discount	07/29/22	2,223.95	
Accretion of Discount	07/29/22	462.57	
US Treasury Note 2.25% Dtd 03/31/2022 Due 03/31/2024 Accretion of Discount	09/30/22	914.53	
<b>Total Non-Cash Transactions</b>		<b>\$ 3,601.05</b>	

SECURITY PRICES CONTAINED IN THIS STATEMENT ARE OBTAINED FROM THE MOST RELIABLE SOURCES AVAILABLE BUT ARE NOT GUARANTEED BY BANK OF THE WEST. QUOTED PRICES MAY NOT EQUAL ACTUAL PRICES BECAUSE OF SECURITY SIZE, MARKET PRICE, TERM AND DEMAND.



**BANK OF THE WEST**  
**BNP PARIBAS**  
**WEALTH MANAGEMENT**

### **Electronic Funds Transfers**

#### **Preauthorized Transfers:**

You may request an electronic fund transfer (EFT), such as an ACH transfer from or deposit to your account, by contacting your account Administrator. You may also preauthorize periodic EFTs by contacting your account Administrator. If you would like to know whether a preauthorized EFT has occurred, please contact your account Administrator at the phone number listed on the first page of your statement. TTY 1-866-936-2689, Monday - Friday, 8 a.m. - 4:30 p.m. Central Time.

#### **Error Resolution Notice:**

If you think a statement or receipt is wrong or if you need more information about an EFT listed on a statement or receipt, telephone your account Administrator at the phone number listed on the first page of your statement, TTY 1-866-936-2689, Monday - Friday, 8 a.m. - 4:30 p.m. Central Time, write to us at Bank of the West, GIFS Operations, 12000 North Washington Street, Suite, 300, Thornton, CO 80241 or e-mail us at [WMGGIFSOperations@bankofthewest.com](mailto:WMGGIFSOperations@bankofthewest.com) as soon as possible. We must hear from you no later than 60 days after we sent the FIRST statement on which the problem or error appeared.

1. Tell us your name and account number (if any).
2. Tell us the dollar amount of the suspected error.
3. Describe the error or the transfer you are unsure about, and explain as clearly as you can why you believe it is an error or why you need more information.

If you contact us verbally, we may require that you send us your complaint or question in writing within 10 business days. We will investigate your complaint and will correct any error promptly. If we take more than 10 business days to do this, we will credit your account for the amount you think is in error, so that you will have the use of the money during the time it takes us to complete our investigation.



**WBSD - CAPITAL PROJECT RESERVE**

Account Number:  
 Statement Period: 07/01/22 - 09/30/22

WEST BAY SANITARY DISTRICT  
 500 LAUREL STREET  
 MENLO PARK CA 94025

**Fiduciary**  
 Chuen Ying Lee  
 (408) 645-3234  
**Portfolio**  
 Michael D. Smith  
 (408) 490-2079

**Asset Allocation**

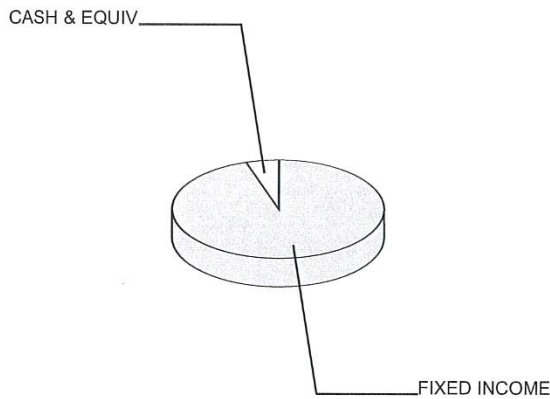

**Asset Valuation**

Description	Market Value	% of Account
Cash & Equiv	272,611.09	4.7%
Fixed Income	5,477,340.25	95.3%
<b>Total Portfolio</b>	<b>\$ 5,749,951.34</b>	<b>100.0%</b>
Accrued Income	24,845.11	
<b>Total Valuation</b>	<b>\$ 5,774,796.45</b>	

**Market Reconciliation**

	Current Period	Year To Date
<b>Beginning Market Value</b>	<b>\$ 5,830,876.97</b>	<b>\$ 5,830,876.97</b>
Income		
Interest.....	38,481.45	38,481.45
Purchased Income.....	-475.75	-475.75
Disbursements.....	-2,518.57	-2,518.57
Realized Gains/(Losses).....	0.00	0.00
Change In Accrued Income.....	-9,737.97	-9,737.97
Change In Market Appreciation/(Depreciation).....	-64,114.90	-64,114.90
Non-Cash Asset Changes.....	-17,714.78	-17,714.78
<b>Ending Market Value</b>	<b>\$ 5,774,796.45</b>	<b>\$ 5,774,796.45</b>



**WBSD - CAPITAL PROJECT RESERVE**

Account Number:  
Statement Period:

07/01/22 - 09/30/22

**Asset Position As of 09/30/22**

Asset Description	Units	Market Value Cost	Est. Annual Income Accruals	Current Yield
<b>Cash Equivalents</b>				
Bank of The West Advantage Acct	73,617.970	73,617.97 73,617.97	1,693.00 609.57	2.30%
US Treasury Bill Due 10/06/2022	200,000.000	198,993.12 199,012.00	0.00 966.88	0.00%
<b>Total Cash Equivalents</b>		<b>\$ 272,611.09</b> <b>\$ 272,629.97</b>	<b>1,693.00</b> <b>1,576.45</b>	<b>0.62%</b>
<b>Fixed Income</b>				
Anz National Intl LTD Fr 3.40% Dtd 03/19/2019 Due 03/19/2024 Non-Callable	60,000.000	58,758.00 62,323.80	2,040.00 68.00	3.47%
American Express Co Sr Gbl Nt 3.00% Dtd 10/30/2017 Due 10/30/2024 Callable	90,000.000	86,838.30 94,822.20	2,700.00 1,132.50	3.11%
Apple Inc Sr Gbl Nt 0.75% Dtd 05/11/2020 Due 05/11/2023 Callable	10,000.000	9,800.10 10,040.40	75.00 29.16	0.77%
Apple Inc Sr Gbl 0.70% Dtd 02/08/2021 Due 02/08/2026 Callable	50,000.000	43,979.00 49,948.00	350.00 51.52	0.80%
Blackrock Inc Sr Nt 3.50% Dtd 03/18/2014 Due 03/18/2024 Callable	60,000.000	59,137.80 62,679.60	2,100.00 75.83	3.55%
California St GO Bds 5.00% Dtd 03/14/2017 Due 08/01/2023 Non-Callable	60,000.000	60,946.80 62,076.60	3,000.00 499.99	4.92%
Clackamas Cnty Ore Sch Dist No GO Bds B 5.00% Dtd 03/02/2017 Due 06/15/2023 Non-Callable	70,000.000	70,911.40 73,213.10	3,500.00 1,030.55	4.94%
Comcast Corp New Sr Nt 3.375% Dtd 05/27/2015 Due 08/15/2025 Callable	45,000.000	43,195.05 48,363.75	1,518.00 194.06	3.52%
Deere John Capital Corp Fr 3.45% Dtd 03/13/2018 Due 03/13/2025 Non-Callable	50,000.000	48,503.50 53,495.50	1,725.00 86.25	3.56%





**WBSD - CAPITAL PROJECT RESERVE**

Account Number:  
 Statement Period:

07/01/22 - 09/30/22

**Asset Position As of 09/30/22**

Asset Description	Units	Market Value Cost	Est. Annual Income Accruals	Current Yield
Federal Home Loan Bks Cons Bds 0.60% Dtd 04/30/2021 Due 12/30/2024 Callable	50,000.000	45,788.50 50,000.00	300.00 125.83	0.66%
Federal Home Loan Bks Cons Bds 0.60% Dtd 04/30/2021 Due 10/30/2024 Callable	100,000.000	92,165.00 100,000.00	600.00 251.66	0.65%
Federal Farm Cr Bks Cons Systemwide Bds 0.71% Dtd 04/21/2021 Due 04/21/2025 Callable	300,000.000	272,643.00 300,000.00	2,130.00 946.66	0.78%
Federal Natl Mtg Assn Gtd Passthru CTF Pool #AN4889 2.750% Dtd 03/01/2017 Due 03/01/2024 IPD24	200,000.000	195,436.00 211,076.00	5,500.00 458.33	2.81%
Kla Tencor Corp Sr Gbl Nt 4.65% Dtd 11/06/2014 Due 11/01/2024 Callable	50,000.000	49,830.00 54,322.50	2,325.00 968.74	4.67%
LA Canada Calif Uni Sch Dist Taxable GO Ref Bds Taxable 1.65% Dtd 04/28/2020 Due 08/01/2023 Non-Callable	60,000.000	58,650.60 60,000.00	990.00 165.00	1.69%
League City Tex Combi Tax and Rev Ctfs O 5.00% Dtd 07/01/2017 Due 02/15/2023 Non-Callable	65,000.000	65,449.15 66,210.95	3,250.00 415.27	4.97%
Long Is Pwr Auth N Y Elec Sys Taxable Gen Bds 2020 C Taxable 0.764% Dtd 08/20/2020 Due 03/01/2023 Callable	90,000.000	88,672.50 90,000.00	687.00 57.30	0.78%
Modesto Calif Irr Dist Fing Au Rev Bds 2015a 5.00% Dtd 07/15/2015 Due 10/01/2023 Non-Callable	90,000.000	91,627.20 96,153.10	4,500.00 2,250.00	4.91%
New Mexico St Severance Tax Tax Bds 2015 A 5.00% Dtd 08/12/2015 Due 07/01/2023 Non-Callable	70,000.000	70,949.90 73,255.80	3,500.00 874.99	4.93%
New York Life Gbl Fdg MTN 144a Sr Sec Gbl 1.10% Dtd 05/07/2020 Due 05/05/2023 Non-Callable	90,000.000	88,395.30 90,654.30	990.00 401.50	1.12%
San Juan Calif Uni Sch Dist Bds Zero Cpn Dtd 08/02/2001 Due 08/01/2023 Non-Callable	60,000.000	58,380.00 59,822.51	0.00	0.00%



**WBSD - CAPITAL PROJECT RESERVE**

**Account Number:**  
**Statement Period:**

**07/01/22 - 09/30/22**

**Asset Position As of 09/30/22**

<b>Asset Description</b>	<b>Units</b>	<b>Market Value Cost</b>	<b>Est. Annual Income Accruals</b>	<b>Current Yield</b>
Santa Ana Calif Uni Sch Dist Sch Dist Bds 2008 A Zero Cpn Dtd 08/19/2008 Due 08/01/2023 Non-Callable	125,000.000	121,635.00 124,558.43	0.00	0.00%
Synchrony Financial Sr Gbl Nt 4.25% Dtd 08/11/2014 Due 08/15/2024 Callable	135,000.000	131,631.75 141,790.95	5,737.00 733.12	4.36%
Tarkington Tex Indpt Sch Dist Taxable Unltd Tax Ref Bd Taxable Zero Cpn Dtd 02/01/2021 Due 02/15/2023 Non-Callable	125,000.000	123,080.00 124,808.68	0.00	0.00%
Tennessee Valley Auth Sr Gbl A Bd 0.75% Dtd 05/11/2020 Due 05/15/2025 Non-Callable	300,000.000	273,471.00 303,126.00	2,250.00 850.00	0.82%
Toyota Motor Credit Corp Fr 2.90% Dtd 04/01/2020 Due 03/30/2023 Non-Callable	20,000.000	19,849.20 20,192.40	580.00 1.61	2.92%
Toyota Motor Credit Corp Fr 3.00% Dtd 04/01/2020 Due 04/01/2025 Callable	50,000.000	47,904.50 53,351.00	1,500.00 750.00	3.13%
United Parcel Service Inc Sr Nt 2.50% Dtd 11/14/2017 Due 04/01/2023 Callable	90,000.000	89,244.90 91,683.90	2,250.00 1,125.00	2.52%
US Treasury Note 0.125% Dtd 09/15/2020 Due 09/15/2023	400,000.000	384,568.00 384,828.13	500.00 22.09	0.13%
US Treasury Note 0.125% Dtd 12/15/2020 Due 12/15/2023	160,000.000	152,275.20 153,493.75	200.00 59.01	0.13%
US Treasury Note 0.75% Dtd 03/31/2021 Due 03/31/2026	160,000.000	142,107.20 159,125.00	1,200.00 3.29	0.84%
US Treasury Note 1.00% Dtd 12/15/2021 Due 12/15/2024	240,000.000	223,680.00 228,206.25	2,400.00 708.19	1.07%
US Treasury Note 0.875% Dtd 01/31/2022 Due 01/31/2024	60,000.000	57,325.80 58,544.32	525.00 88.45	0.92%
US Treasury Note 1.625% Dtd 02/15/2016 Due 02/15/2026	100,000.000	91,864.00 95,435.88	1,625.00 207.54	1.77%
US Treasury Note 1.625% Dtd 10/31/2016 Due 10/31/2023	350,000.000	340,210.50 350,511.92	5,687.00 2,380.09	1.67%



**WBSD - CAPITAL PROJECT RESERVE**

Account Number:  
 Statement Period:

07/01/22 - 09/30/22

**Asset Position As of 09/30/22**

Asset Description	Units	Market Value Cost	Est. Annual Income Accruals	Current Yield
US Treasury Note 2.50% Dtd 05/15/2014 Due 05/15/2024	160,000.000	155,451.20 159,243.75	4,000.00 1,510.87	2.57%
US Treasury Note 2.00% Dtd 06/30/2017 Due 06/30/2024	100,000.000	96,180.00 97,906.25	2,000.00 505.43	2.08%
US Treasury Note 2.625% Dtd 02/28/2018 Due 02/28/2023	250,000.000	248,902.50 251,788.15	6,562.00 561.98	2.64%
US Treasury Note 2.625% Dtd 06/30/2018 Due 06/30/2023	250,000.000	247,305.00 253,113.05	6,562.00 1,658.45	2.65%
US Treasury Note 2.50% Dtd 01/31/2019 Due 01/31/2024	100,000.000	97,649.00 99,754.40	2,500.00 421.19	2.56%
US Treasury Note 2.375% Dtd 02/28/2019 Due 02/29/2024	300,000.000	292,125.00 303,441.36	7,125.00 610.15	2.44%
University Calif Revs Gen Rev Bds 2015 A Taxable 2.909% Dtd 03/25/2015 Due 05/15/2023 Callable	90,000.000	89,258.40 91,652.20	2,618.00 989.06	2.93%
Waco Tex Indpt Sch Dist Taxable Unltd Tax Ref Bd Taxable Zero Cpn Dtd 01/01/2021 Due 08/15/2024 Non-Callable	100,000.000	91,637.00 98,979.44	0.00	0.00%
Waco Tex Indpt Sch Dist Taxable Unltd Tax Ref Bd Taxable Zero Cpn Dtd 01/01/2021 Due 08/15/2025 Non-Callable	300,000.000	260,784.00 293,832.52	0.00	0.00%
Washington St Motor Veh Fuel Tax B 2003 C Zero Cpn Dtd 10/02/2002 Due 06/01/2023 Non-Callable	40,000.000	39,144.00 39,906.60	0.00	0.00%
<b>Total Fixed Income</b>		<b>\$ 5,477,340.25</b> <b>\$ 5,747,732.44</b>	<b>97,601.00</b> <b>23,268.66</b>	<b>1.78%</b>
<b>Cash</b>				
Principal Cash		0.00 0.00	0.00	0.00%
Income Cash		0.00 0.00	0.00	0.00%
<b>Total Cash</b>		<b>\$ 0.00</b> <b>\$ 0.00</b>	<b>0.00</b> <b>0.00</b>	<b>0.00%</b>



**WBSD - CAPITAL PROJECT RESERVE**

Account Number:  
 Statement Period:

07/01/22 - 09/30/22

**Asset Position As of 09/30/22**

Asset Description	Units	Market Value Cost	Est. Annual Income Accruals	Current Yield
<b>Total Market Value</b>		\$ 5,749,951.34	99,294.00	1.73%
		\$ 6,020,362.41	24,845.11	
<b>Total Market Value Plus Accruals</b>		\$ 5,774,796.45		

**Income Activity**

	Date	Income Cash	Principal Cash
<b>Interest Income</b>			
Bank of The West Advantage Acct			
Int To 06/30/22	07/01/22		16.57
Int To 07/31/22	08/01/22		109.86
Int To 08/31/22	09/01/22		570.00
Anz National Intl LTD Fr 3.40% Dtd 03/19/2019 Due 03/19/2024 Non-Callable			
Int To 09/19/22 on 60,000	09/19/22		1,020.00
Apple Inc Sr Gbl 0.70% Dtd 02/08/2021 Due 02/08/2026 Callable			
Int To 08/08/22 on 50,000	08/08/22		175.00
Austin Tex Indpt Sch Dist Ultd Tax Sch Bldg and RE 5.00% Dtd 04/10/2019 Due 08/01/2022 Non-Callable			
Int To 08/01/22 on 100,000	08/01/22		2,500.00
Blackrock Inc Sr Nt 3.50% Dtd 03/18/2014 Due 03/18/2024 Callable			
Int To 09/18/22 on 60,000	09/19/22		1,050.00
California St GO Bds 5.00% Dtd 03/14/2017 Due 08/01/2023 Non-Callable			
Int To 08/01/22 on 60,000	08/01/22		1,500.00
Comcast Corp New Sr Nt 3.375% Dtd 05/27/2015 Due 08/15/2025 Callable			
Int To 08/15/22 on 45,000	08/15/22		759.37
Deere John Capital Corp Fr 3.45% Dtd 03/13/2018 Due 03/13/2025 Non-Callable			
Int To 09/13/22 on 50,000	09/13/22		862.50



**WBSD - CAPITAL PROJECT RESERVE**

Account Number:  
 Statement Period: 07/01/22 - 09/30/22

Income Activity			
	Date	Income Cash	Principal Cash
Disney Walt Co Sr Gbl Nt 1.65% Dtd 09/06/2019 Due 09/01/2022 Callable Int To 09/01/22 on 20,000	09/01/22		165.00
Exxon Mobil Corp Sr Gbl Nt 1.902% Dtd 08/16/2019 Due 08/16/2022 Callable Int To 08/16/22 on 55,000	08/16/22		523.05
Federal Home Loan Bks Cons Bds 1.85% Dtd 08/15/2017 Due 08/15/2022 Non-Callable Int To 08/15/22 on 235,000	08/15/22		2,173.75
Federal Farm Cr Bks Cons Systemwide Bds 1.90% Dtd 07/19/2017 Due 07/19/2022 Non-Callable Int To 07/19/22 on 60,000	07/19/22		570.00
Federal Farm Cr Bks Cons Systemwide Bds 1.90% Dtd 08/03/2017 Due 08/03/2022 Non-Callable Int To 08/03/22 on 60,000	08/03/22		570.00
Federal Natl Mtg Assn Gtd Passthru CTF Pool #AN4889 2.750% Dtd 03/01/2017 Due 03/01/2024 IPD24 Int For June 2022 on 200000 Int For July 2022 on 200000 Int For August 2022 on 200000	07/25/22 08/25/22 09/26/22		458.33 473.61 473.61
JPMorgan Chase & Co Sr Nt 3.25% Dtd 09/24/2012 Due 09/23/2022 Non-Callable Int To 09/23/22 on 20,000	09/23/22		325.00
LA Canada Calif Uni Sch Dist Taxable GO Ref Bds Taxable 1.65% Dtd 04/28/2020 Due 08/01/2023 Non-Callable Int To 08/01/22 on 60,000	08/01/22		495.00
League City Tex Combi Tax and Rev Ctfs O 5.00% Dtd 07/01/2017 Due 02/15/2023 Non-Callable Int To 08/15/22 on 65,000	08/15/22		1,625.00



**WBSD - CAPITAL PROJECT RESERVE**

Account Number:  
 Statement Period:

07/01/22 - 09/30/22

Income Activity			
	Date	Income Cash	Principal Cash
Long Is Pwr Auth N Y Elec Sys Taxable Gen Bds 2020 C Taxable 0.764% Dtd 08/20/2020 Due 03/01/2023 Callable Int To 09/01/22 on 90,000	09/01/22		343.80
Massachusetts St GO Bds 2013b 5.00% Dtd 07/02/2013 Due 08/01/2022 Non-Callable Int To 08/01/22 on 75,000	08/01/22		1,875.00
New Mexico St Severance Tax Tax Bds 2015 A 5.00% Dtd 08/12/2015 Due 07/01/2023 Non-Callable Int To 07/01/22 on 70,000	07/01/22		1,750.00
New York St Dorm Auth Revs Non Univ Rev Bds 2019b Taxable 2.839% Dtd 02/21/2019 Due 07/01/2022 Callable Int To 07/01/22 on 100,000	07/01/22		1,419.50
Santa Ana Calif Fing Auth Wtr Ref Bds 5.00% Dtd 08/07/2014 Due 09/01/2022 Non-Callable Int To 09/01/22 on 50,000	09/01/22		1,250.00
Synchrony Financial Sr Gbl Nt 4.25% Dtd 08/11/2014 Due 08/15/2024 Callable Int To 08/15/22 on 135,000	08/15/22		2,868.75
Toyota Motor Credit Corp Fr 2.90% Dtd 04/01/2020 Due 03/30/2023 Non-Callable Int To 09/30/22 on 20,000	09/30/22		290.00
US Treasury Note 0.75% Dtd 03/31/2021 Due 03/31/2026 Int To 09/30/22 on 160,000	09/30/22		600.00
US Treasury Note 0.875% Dtd 01/31/2022 Due 01/31/2024 Int 01/31/22 To 07/31/22 on 60000	08/01/22		262.50
US Treasury Note 1.625% Dtd 02/15/2016 Due 02/15/2026 Int To 08/15/22 on 100,000	08/15/22		812.50
US Treasury Note 2.625% Dtd 02/28/2018 Due 02/28/2023 Int To 08/31/22 on 250,000	08/31/22		3,281.25



**WBSD - CAPITAL PROJECT RESERVE**

Account Number:  
 Statement Period:

07/01/22 - 09/30/22

Income Activity			
	Date	Income Cash	Principal Cash
US Treasury Note 2.50% Dtd 01/31/2019 Due 01/31/2024 Int To 07/31/22 on 100,000	08/01/22		1,250.00
US Treasury Note 2.375% Dtd 02/28/2019 Due 02/29/2024 Int To 08/31/22 on 300,000	08/31/22		3,562.50
Washington St Various Purp GO Ref Bds R 5.00% Dtd 07/14/2016 Due 08/01/2022 Non-Callable Int To 08/01/22 on 100,000	08/01/22		2,500.00
<b>Total Interest Income</b>		<b>\$ 0.00</b>	<b>\$ 38,481.45</b>
<b>Purchased Income</b>			
US Treasury Note 0.125% Dtd 09/15/2020 Due 09/15/2023 Accrued Int To 09/23/22 Paid on Purchase of 400,000	09/23/22		-11.05
US Treasury Note 0.125% Dtd 12/15/2020 Due 12/15/2023 Accrued Int To 08/11/22 Paid on Purchase of 160,000	08/11/22		-31.15
US Treasury Note 1.00% Dtd 12/15/2021 Due 12/15/2024 Accrued Int To 08/11/22 Paid on Purchase of 240,000	08/11/22		-373.77
US Treasury Note 2.00% Dtd 06/30/2017 Due 06/30/2024 Accrued Int To 07/11/22 Paid on Purchase of 100,000	07/11/22		-59.78
<b>Total Purchased Income</b>		<b>\$ 0.00</b>	<b>\$ -475.75</b>
<b>Total Income</b>		<b>\$ 0.00</b>	<b>\$ 38,005.70</b>

Disbursement Activity			
	Date	Income Cash	Principal Cash
<b>Fees/Expenses</b>			
Monthly Fee To 06/30/22	07/15/22		-851.63
Monthly Fee To 07/31/22	08/15/22		-834.19



**WBSD - CAPITAL PROJECT RESERVE**

Account Number:  
 Statement Period:

07/01/22 - 09/30/22

Disbursement Activity			
	Date	Income Cash	Principal Cash
Monthly Fee To 08/31/22	09/15/22		-832.75
<b>Total Fees/Expenses</b>		<b>\$ 0.00</b>	<b>\$ -2,518.57</b>
<b>Total Disbursements</b>		<b>\$ 0.00</b>	<b>\$ -2,518.57</b>

Purchase Activity			
	Date	Income Cash	Principal Cash
Bank of The West Advantage Acct Purchases (15) 07/01/22 To 09/30/22	09/30/22		-893,156.45
US Treasury Note 0.125% Dtd 09/15/2020 Due 09/15/2023 Purchased 400000 09/22/22 From First Tennessee Bank NA Bond Di @ 96.207031	09/23/22		-384,828.13
US Treasury Note 0.125% Dtd 12/15/2020 Due 12/15/2023 Purchased 160000 08/10/22 From Wells Fargo Securities, LLC @ 95.933593	08/11/22		-153,493.75
US Treasury Note 1.00% Dtd 12/15/2021 Due 12/15/2024 Purchased 240000 08/10/22 From Morgan Stanley & Co @ 95.085938	08/11/22		-228,206.25
US Treasury Note 2.00% Dtd 06/30/2017 Due 06/30/2024 Purchased 100000 07/08/22 From Wells Fargo Securities, LLC @ 97.90625	07/11/22		-97,906.25
<b>Total Purchases</b>		<b>\$ 0.00</b>	<b>\$ -1,757,590.83</b>





**WBSD - CAPITAL PROJECT RESERVE**

**Account Number:**  
**Statement Period:**

**07/01/22 - 09/30/22**

Sale Activity			
	Date	Proceeds	Realized Gain/Loss
Bank of The West Advantage Acct Sales (6) 07/01/22 To 09/30/22	09/30/22	847,103.70	
Austin Tex Indpt Sch Dist Ultd Tax Sch Bldg and RE 5.00% Dtd 04/10/2019 Due 08/01/2022 Non-Callable Recd Proceeds on Maturity of 100,000 Par Value	08/01/22	100,000.00	
Disney Walt Co Sr Gbl Nt 1.65% Dtd 09/06/2019 Due 09/01/2022 Callable Recd Proceeds on Maturity of 20,000 Par Value	09/01/22	20,000.00	
Exxon Mobil Corp Sr Gbl Nt 1.902% Dtd 08/16/2019 Due 08/16/2022 Callable Recd Proceeds on Maturity of 55,000 Par Value	08/16/22	55,000.00	
Federal Home Loan Bks Cons Bds 1.85% Dtd 08/15/2017 Due 08/15/2022 Non-Callable Recd Proceeds on Maturity of 235,000 Par Value	08/15/22	235,000.00	
Federal Farm Cr Bks Cons Systemwide Bds 1.90% Dtd 07/19/2017 Due 07/19/2022 Non-Callable Recd Proceeds on Maturity of 60,000 Par Value	07/19/22	60,000.00	
Federal Farm Cr Bks Cons Systemwide Bds 1.90% Dtd 08/03/2017 Due 08/03/2022 Non-Callable Recd Proceeds on Maturity of 60,000 Par Value	08/03/22	60,000.00	
JPMorgan Chase & Co Sr Nt 3.25% Dtd 09/24/2012 Due 09/23/2022 Non-Callable Recd Proceeds on Maturity of 20,000 Par Value	09/23/22	20,000.00	
Massachusetts St GO Bds 2013b 5.00% Dtd 07/02/2013 Due 08/01/2022 Non-Callable Recd Proceeds on Maturity of 75,000 Par Value	08/01/22	75,000.00	



**WBSD - CAPITAL PROJECT RESERVE**

Account Number:  
 Statement Period:

07/01/22 - 09/30/22

Sale Activity			
	Date	Proceeds	Realized Gain/Loss
New York St Dorm Auth Revs Non Univ Rev Bds 2019b Taxable 2.839% Dtd 02/21/2019 Due 07/01/2022 Callable Recd Proceeds on Maturity of 100,000 Par Value	07/01/22	100,000.00	
Santa Ana Calif Fing Auth Wtr Ref Bds 5.00% Dtd 08/07/2014 Due 09/01/2022 Non-Callable Recd Proceeds on Maturity of 50,000 Par Value	09/01/22	50,000.00	
Washington St Various Purp GO Ref Bds R 5.00% Dtd 07/14/2016 Due 08/01/2022 Non-Callable Recd Proceeds on Maturity of 100,000 Par Value	08/01/22	100,000.00	
<b>Total Sales</b>		<b>\$ 1,722,103.70</b>	<b>\$ 0.00</b>

Non-Cash Activity		
	Date	Cost
Anz National Intl LTD Fr 3.40% Dtd 03/19/2019 Due 03/19/2024 Non-Callable Amortization of Premium	09/19/22	-768.60
Austin Tex Indpt Sch Dist Ultd Tax Sch Bldg and RE 5.00% Dtd 04/10/2019 Due 08/01/2022 Non-Callable Amortization of Premium	08/01/22	-1,966.00
Blackrock Inc Sr Nt 3.50% Dtd 03/18/2014 Due 03/18/2024 Callable Amortization of Premium	09/16/22	-889.20
California St GO Bds 5.00% Dtd 03/14/2017 Due 08/01/2023 Non-Callable Amortization of Premium	08/01/22	-1,026.60
Comcast Corp New Sr Nt 3.375% Dtd 05/27/2015 Due 08/15/2025 Callable Amortization of Premium	08/15/22	-552.60



**WBSD - CAPITAL PROJECT RESERVE**

Account Number:  
 Statement Period:

07/01/22 - 09/30/22

Non-Cash Activity		
	Date	Cost
Deere John Capital Corp Fr 3.45% Dtd 03/13/2018 Due 03/13/2025 Non-Callable Amortization of Premium	09/13/22	-692.50
Disney Walt Co Sr Gbl Nt 1.65% Dtd 09/06/2019 Due 09/01/2022 Callable Amortization of Premium	09/01/22	-94.60
Exxon Mobil Corp Sr Gbl Nt 1.902% Dtd 08/16/2019 Due 08/16/2022 Callable Amortization of Premium	08/16/22	-145.60
	08/16/22	-255.15
Federal Home Loan Bks Cons Bds 1.85% Dtd 08/15/2017 Due 08/15/2022 Non-Callable Amortization of Premium	08/15/22	-197.40
Federal Farm Cr Bks Cons Systemwide Bds 1.90% Dtd 07/19/2017 Due 07/19/2022 Non-Callable Amortization of Premium	07/19/22	-29.40
Federal Farm Cr Bks Cons Systemwide Bds 1.90% Dtd 08/03/2017 Due 08/03/2022 Non-Callable Amortization of Premium	08/03/22	-16.20
JPMorgan Chase & Co Sr Nt 3.25% Dtd 09/24/2012 Due 09/23/2022 Non-Callable Amortization of Premium	09/23/22	-234.20
League City Tex Combi Tax and Rev Ctfs O 5.00% Dtd 07/01/2017 Due 02/15/2023 Non-Callable Amortization of Premium	08/15/22	-1,203.80
Massachusetts St GO Bds 2013b 5.00% Dtd 07/02/2013 Due 08/01/2022 Non-Callable Amortization of Premium	08/01/22	-1,467.75
New Mexico St Severance Tax Tax Bds 2015 A 5.00% Dtd 08/12/2015 Due 07/01/2023 Non-Callable Amortization of Premium	07/01/22	-1,161.50
	07/01/22	-462.20



**WBSD - CAPITAL PROJECT RESERVE**

Account Number:  
 Statement Period:

07/01/22 - 09/30/22

Non-Cash Activity		
	Date	Cost
New York St Dorm Auth Revs Non Univ Rev Bds 2019b Taxable 2.839% Dtd 02/21/2019 Due 07/01/2022 Callable Amortization of Premium	07/01/22	-559.00
San Juan Calif Uni Sch Dist Bds Zero Cpn Dtd 08/02/2001 Due 08/01/2023 Non-Callable		
Accretion of Discount	07/29/22	13.80
Accretion of Discount	07/29/22	3.86
Accretion of Discount	08/31/22	13.80
Accretion of Discount	08/31/22	3.86
Accretion of Discount	09/30/22	13.80
Accretion of Discount	09/30/22	3.86
Santa Ana Calif Fing Auth Wtr Ref Bds 5.00% Dtd 08/07/2014 Due 09/01/2022 Non-Callable Amortization of Premium	09/01/22	-868.00
Santa Ana Calif Uni Sch Dist Sch Dist Bds 2008 A Zero Cpn Dtd 08/19/2008 Due 08/01/2023 Non-Callable		
Accretion of Discount	07/29/22	29.03
Accretion of Discount	07/29/22	14.95
Accretion of Discount	08/31/22	29.03
Accretion of Discount	08/31/22	14.95
Accretion of Discount	09/30/22	29.03
Accretion of Discount	09/30/22	14.95
Synchrony Financial Sr Gbl Nt 4.25% Dtd 08/11/2014 Due 08/15/2024 Callable		
Amortization of Premium	08/15/22	-553.95
Amortization of Premium	08/15/22	-1,109.70
Tarkington Tex Indpt Sch Dist Taxable Unltd Tax Ref Bd Taxable Zero Cpn Dtd 02/01/2021 Due 02/15/2023 Non-Callable		
Accretion of Discount	07/29/22	42.51
Accretion of Discount	08/31/22	42.51
Accretion of Discount	09/30/22	42.51
Toyota Motor Credit Corp Fr 2.90% Dtd 04/01/2020 Due 03/30/2023 Non-Callable		
Amortization of Premium	09/30/22	-191.80



**WBSD - CAPITAL PROJECT RESERVE**

Account Number:

Statement Period:

07/01/22 - 09/30/22

Non-Cash Activity		
	Date	Cost
US Treasury Note 0.875% Dtd 01/31/2022 Due 01/31/2024 Accretion of Discount	07/29/22	177.91
US Treasury Note 1.625% Dtd 02/15/2016 Due 02/15/2026 Accretion of Discount	08/15/22	369.47
US Treasury Note 2.625% Dtd 02/28/2018 Due 02/28/2023 Amortization of Premium	08/31/22	-1,777.60
US Treasury Note 2.50% Dtd 01/31/2019 Due 01/31/2024 Accretion of Discount	07/29/22	39.56
US Treasury Note 2.375% Dtd 02/28/2019 Due 02/29/2024 Amortization of Premium	08/31/22	-1,128.98
Waco Tex Indpt Sch Dist Taxable Unltd Tax Ref Bd Taxable Zero Cpn Dtd 01/01/2021 Due 08/15/2024 Non-Callable Accretion of Discount	07/29/22	45.34
Accretion of Discount	08/31/22	45.34
Accretion of Discount	09/30/22	45.34
Waco Tex Indpt Sch Dist Taxable Unltd Tax Ref Bd Taxable Zero Cpn Dtd 01/01/2021 Due 08/15/2025 Non-Callable Accretion of Discount	07/29/22	89.38
Accretion of Discount	07/29/22	89.38
Accretion of Discount	08/31/22	89.38
Accretion of Discount	08/31/22	89.38
Accretion of Discount	09/30/22	89.38
Accretion of Discount	09/30/22	89.38
Washington St Motor Veh Fuel Tax B 2003 C Zero Cpn Dtd 10/02/2002 Due 06/01/2023 Non-Callable Accretion of Discount	07/29/22	11.62
Accretion of Discount	08/31/22	11.62
Accretion of Discount	09/30/22	11.62
Washington St Various Purp GO Ref Bds R 5.00% Dtd 07/14/2016 Due 08/01/2022 Non-Callable Amortization of Premium	08/01/22	-1,969.00
<b>Total Non-Cash Transactions</b>		<b>\$ -17,714.78</b>



**BANK OF THE WEST**  
**BNP PARIBAS**  
WEALTH MANAGEMENT

**WBSD - CAPITAL PROJECT RESERVE**

**Account Number:**  
**Statement Period:**

**07/01/22 - 09/30/22**

SECURITY PRICES CONTAINED IN THIS STATEMENT ARE OBTAINED FROM THE MOST RELIABLE SOURCES AVAILABLE BUT ARE NOT GUARANTEED BY BANK OF THE WEST. QUOTED PRICES MAY NOT EQUAL ACTUAL PRICES BECAUSE OF SECURITY SIZE, MARKET PRICE, TERM AND DEMAND.



**BANK OF THE WEST**  
**BNP PARIBAS**  
WEALTH MANAGEMENT

### **Electronic Funds Transfers**

#### **Preauthorized Transfers:**

You may request an electronic fund transfer (EFT), such as an ACH transfer from or deposit to your account, by contacting your account Administrator. You may also preauthorize periodic EFTs by contacting your account Administrator. If you would like to know whether a preauthorized EFT has occurred, please contact your account Administrator at the phone number listed on the first page of your statement. TTY 1-866-936-2689, Monday - Friday, 8 a.m. - 4:30 p.m. Central Time.

#### **Error Resolution Notice:**

If you think a statement or receipt is wrong or if you need more information about an EFT listed on a statement or receipt, telephone your account Administrator at the phone number listed on the first page of your statement, TTY 1-866-936-2689, Monday - Friday, 8 a.m. - 4:30 p.m. Central Time, write to us at Bank of the West, GIFS Operations, 12000 North Washington Street, Suite, 300, Thornton, CO 80241 or e-mail us at [WMGGIFSOperations@bankofthewest.com](mailto:WMGGIFSOperations@bankofthewest.com) as soon as possible. We must hear from you no later than 60 days after we sent the FIRST statement on which the problem or error appeared.

1. Tell us your name and account number (if any).
2. Tell us the dollar amount of the suspected error.
3. Describe the error or the transfer you are unsure about, and explain as clearly as you can why you believe it is an error or why you need more information.

If you contact us verbally, we may require that you send us your complaint or question in writing within 10 business days. We will investigate your complaint and will correct any error promptly. If we take more than 10 business days to do this, we will credit your account for the amount you think is in error, so that you will have the use of the money during the time it takes us to complete our investigation.



**BANK OF THE WEST**  
**BNP PARIBAS**  
 WEALTH MANAGEMENT

**WBSD - EMERGENCY CAPITAL RESERVE**

Account Number:  
 Statement Period: 07/01/22 - 09/30/22

WEST BAY SANITARY DISTRICT  
 500 LAUREL STREET  
 MENLO PARK CA 94025

**Fiduciary**  
 Chuen Ying Lee  
 (408) 645-3234  
**Portfolio**  
 Michael D. Smith  
 (408) 490-2079

**Asset Allocation**

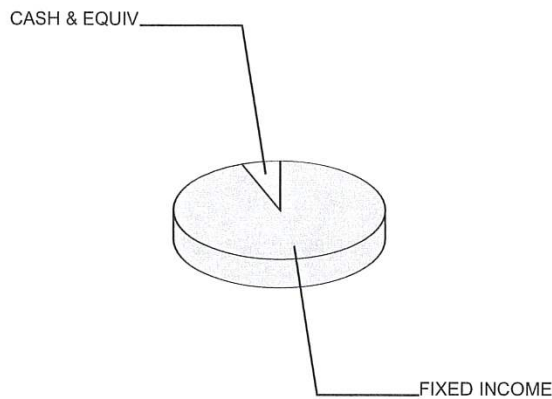

**Asset Valuation**

Description	Market Value	% of Account
Cash & Equiv	271,516.06	5.7%
Fixed Income	4,531,909.93	94.4%
<b>Total Portfolio</b>	<b>\$ 4,803,425.99</b>	<b>100.0%</b>
Accrued Income	25,019.47	
<b>Total Valuation</b>	<b>\$ 4,828,445.46</b>	

**Market Reconciliation**

	Current Period	Year To Date
<b>Beginning Market Value</b>	<b>\$ 4,877,961.83</b>	<b>\$ 4,877,961.83</b>
Income		
Interest.....	28,924.17	28,924.17
Purchased Income.....	-681.04	-681.04
Disbursements.....	-2,106.08	-2,106.08
Realized Gains/(Losses).....	-522.32	-522.32
Change In Accrued Income.....	-3,086.84	-3,086.84
Change In Market Appreciation/(Depreciation).....	-58,636.00	-58,636.00
Non-Cash Asset Changes.....	-13,408.26	-13,408.26
<b>Ending Market Value</b>	<b>\$ 4,828,445.46</b>	<b>\$ 4,828,445.46</b>





**WBSD - EMERGENCY CAPITAL RESERVE**

Account Number:  
Statement Period:

07/01/22 - 09/30/22

**Asset Position As of 09/30/22**

Asset Description	Units	Market Value Cost	Est. Annual Income Accruals	Current Yield
<b>Cash Equivalents</b>				
Bank of The West Advantage Acct	122,271.220	122,271.22 122,271.22	2,812.00 362.36	2.30%
US Treasury Bill Due 10/06/2022	150,000.000	149,244.84 149,259.00	0.00 725.16	0.00%
<b>Total Cash Equivalents</b>		<b>\$ 271,516.06</b> <b>\$ 271,530.22</b>	<b>2,812.00</b> <b>1,087.52</b>	<b>1.04%</b>
<b>Fixed Income</b>				
Anz National Intl LTD Fr 3.40% Dtd 03/19/2019 Due 03/19/2024 Non-Callable	50,000.000	48,965.00 51,936.50	1,700.00 56.66	3.47%
American Express Co Sr Gbl 2.50% Dtd 07/30/2019 Due 07/30/2024 Callable	100,000.000	95,776.00 102,828.00	2,500.00 423.61	2.61%
American Tower Corp Sr Gbl Nt 3.00% Dtd 12/08/2017 Due 06/15/2023 Callable	55,000.000	54,292.70 56,334.85	1,650.00 485.83	3.04%
Apple Inc Sr Gbl Nt 0.75% Dtd 05/11/2020 Due 05/11/2023 Callable	25,000.000	24,500.25 25,101.00	187.00 72.91	0.77%
Apple Inc Sr Gbl 0.70% Dtd 02/08/2021 Due 02/08/2026 Callable	50,000.000	43,979.00 49,948.00	350.00 51.52	0.80%
Asotin Cnty Wash Taxable GO LTD Tax Bds 2021 B Taxable 0.583% Dtd 02/25/2021 Due 12/01/2024 Non-Callable	100,000.000	91,937.00 100,000.00	583.00 194.33	0.63%
Beverly Hills Calif Uni Sch Di GO Bds Zero Cpn Dtd 02/10/2009 Due 08/01/2023 Non-Callable	50,000.000	48,677.50 49,841.85	0.00	0.00%
Blackrock Inc Sr Nt 3.50% Dtd 03/18/2014 Due 03/18/2024 Callable	100,000.000	98,563.00 104,268.50	3,500.00 126.38	3.55%
Cashmere Wash Wtr & Swr Rev Taxable Ref Bds 2021b Taxable 0.658% Dtd 02/24/2021 Due 12/01/2024 Non-Callable	100,000.000	91,926.00 100,000.00	658.00 219.33	0.72%



**WBSD - EMERGENCY CAPITAL RESERVE**

Account Number:  
 Statement Period:

07/01/22 - 09/30/22

**Asset Position As of 09/30/22**

Asset Description	Units	Market Value Cost	Est. Annual Income Accruals	Current Yield
Comcast Corp New Sr Nt 3.375% Dtd 05/27/2015 Due 08/15/2025 Callable	55,000.000	52,793.95 59,111.25	1,856.00 237.18	3.52%
Deere John Capital Corp Fr 3.45% Dtd 03/13/2018 Due 03/13/2025 Non-Callable	40,000.000	38,802.80 42,796.40	1,380.00 68.99	3.56%
Deschutes Cnty Ore Administrat GO Bds 5.00% Dtd 08/31/2017 Due 06/15/2023 Non-Callable	45,000.000	45,601.65 47,028.15	2,250.00 662.50	4.93%
Federal Home Loan Bks Cons Bds 0.60% Dtd 04/30/2021 Due 12/30/2024 Callable	270,000.000	247,257.90 270,000.00	1,620.00 679.50	0.66%
Federal Home Loan Bks Cons Bds 0.60% Dtd 04/30/2021 Due 10/30/2024 Callable	100,000.000	92,165.00 100,000.00	600.00 251.66	0.65%
Federal Farm Cr Bks Cons Systemwide Bds 0.71% Dtd 04/21/2021 Due 04/21/2025 Callable	100,000.000	90,881.00 100,000.00	710.00 315.55	0.78%
Longview Tex Indpt Sch Dist Ultd Tax Ref Bds 5.00% Dtd 04/15/2016 Due 02/15/2023 Non-Callable	55,000.000	55,398.20 56,287.55	2,750.00 351.38	4.96%
Los Angeles Calif Mun Impt COR Bds 2019a 5.00% Dtd 06/26/2019 Due 11/01/2023 Non-Callable	65,000.000	66,234.35 68,361.80	3,250.00 1,354.16	4.91%
Mountain View Los Altos Calif GO Bds 2010a Zero Cpn Dtd 09/09/2010 Due 08/01/2023 Non-Callable	50,000.000	48,701.50 49,854.27	0.00	0.00%
New York Life Gbl Fdg MTN 144a Sr Sec Gbl 1.10% Dtd 05/07/2020 Due 05/05/2023 Non-Callable	50,000.000	49,108.50 50,362.50	550.00 223.05	1.12%
New York N Y GO Bds Subser Taxable 4.669% Dtd 10/15/2009 Due 10/01/2022 Callable	45,000.000	45,000.00 45,594.45	2,101.00 1,050.52	4.67%
Oklahoma St Capitol Impt Auth Bds 2019 C 4.00% Dtd 09/10/2019 Due 01/01/2023 Non-Callable	50,000.000	50,121.50 50,885.50	2,000.00 500.00	3.99%
Paypal Hldgs Inc Sr Gbl 2.40% Dtd 09/26/2019 Due 10/01/2024 Callable	96,000.000	91,704.96 99,864.34	2,304.00 1,152.00	2.51%



**WBSD - EMERGENCY CAPITAL RESERVE**

Account Number:  
Statement Period:

07/01/22 - 09/30/22

**Asset Position As of 09/30/22**

Asset Description	Units	Market Value Cost	Est. Annual Income Accruals	Current Yield
Putnam Cnty Tenn GO Sch Bds 2.625% Dtd 06/06/2013 Due 04/01/2026 Prerefunded 04/01/2023 @ 100.000 Callable	45,000.000	44,887.95 46,032.30	1,181.00 590.62	2.63%
San Francisco Calif City & Cnt Wastewtr Rev Bds 2010b Taxable 4.75% Dtd 06/08/2010 Due 10/01/2023 Callable	70,000.000	70,428.40 74,393.00	3,325.00 1,662.49	4.72%
Small Business Admin Gtd Ln Pool Ctfs 4.34% Dtd 03/17/2004 Due 03/01/2024 Callable	1,493.360	1,482.37 2,354.21	64.00 37.33	4.37%
State Str Corp Sr Sb Nt 3.10% Dtd 05/15/2013 Due 05/15/2023 Non-Callable	100,000.000	99,153.00 102,594.00	3,100.00 1,171.11	3.13%
Synchrony Financial Sr Gbl Nt 4.25% Dtd 08/11/2014 Due 08/15/2024 Callable	55,000.000	53,627.75 57,763.75	2,337.00 298.68	4.36%
Tamalpais Calif Un High Sch Di GO Ref Bds 5.00% Dtd 11/25/2014 Due 08/01/2023 Non-Callable	60,000.000	60,936.00 62,767.80	3,000.00 499.99	4.92%
Tennessee Valley Auth Sr Gbl A Bd 0.75% Dtd 05/11/2020 Due 05/15/2025 Non-Callable	100,000.000	91,157.00 101,042.00	750.00 283.33	0.82%
Global Pmts Inc Sr Gbl Nt 4.00% Dtd 05/11/2018 Due 06/01/2023 Callable	75,000.000	74,425.50 77,506.50	3,000.00 999.99	4.03%
Toyota Motor Credit Corp Fr 2.90% Dtd 04/01/2020 Due 03/30/2023 Non-Callable	90,000.000	89,321.40 90,867.00	2,610.00 7.25	2.92%
Toyota Motor Credit Corp Fr 3.00% Dtd 04/01/2020 Due 04/01/2025 Callable	80,000.000	76,647.20 85,174.80	2,400.00 1,200.00	3.13%
United Parcel Service Inc Sr Nt 2.50% Dtd 11/14/2017 Due 04/01/2023 Callable	100,000.000	99,161.00 101,862.00	2,500.00 1,249.99	2.52%
US Treasury Note 0.125% Dtd 09/15/2020 Due 09/15/2023	200,000.000	192,284.00 192,414.06	250.00 11.05	0.13%
US Treasury Note 0.125% Dtd 12/15/2020 Due 12/15/2023	60,000.000	57,103.20 57,560.16	75.00 22.13	0.13%



**WBSD - EMERGENCY CAPITAL RESERVE**

Account Number:  
 Statement Period:

07/01/22 - 09/30/22

**Asset Position As of 09/30/22**

Asset Description	Units	Market Value Cost	Est. Annual Income Accruals	Current Yield
US Treasury Note 0.375% Dtd 08/15/2021 Due 08/15/2024	100,000.000	93,039.00 94,111.77	375.00 47.89	0.40%
US Treasury Note 0.50% Dtd 11/30/2021 Due 11/30/2023	50,000.000	47,863.50 48,244.14	250.00 84.02	0.52%
US Treasury Note 1.00% Dtd 12/15/2021 Due 12/15/2024	120,000.000	111,840.00 114,103.13	1,200.00 354.10	1.07%
US Treasury Note 0.875% Dtd 01/31/2022 Due 01/31/2024	100,000.000	95,543.00 96,713.30	875.00 147.41	0.92%
US Treasury Note 2.25% Dtd 03/31/2022 Due 03/31/2024	50,000.000	48,508.00 49,738.70	1,125.00 3.09	2.32%
US Treasury Note 1.625% Dtd 02/15/2016 Due 02/15/2026	200,000.000	183,728.00 190,871.76	3,250.00 415.08	1.77%
US Treasury Note 1.625% Dtd 10/31/2016 Due 10/31/2023	250,000.000	243,007.50 250,365.66	4,062.00 1,700.06	1.67%
US Treasury Note 2.50% Dtd 05/15/2014 Due 05/15/2024	120,000.000	116,588.40 119,432.81	3,000.00 1,133.15	2.57%
US Treasury Note 2.00% Dtd 06/30/2017 Due 06/30/2024	100,000.000	96,180.00 97,906.25	2,000.00 505.43	2.08%
US Treasury Note 2.625% Dtd 02/28/2018 Due 02/28/2023	100,000.000	99,561.00 100,715.26	2,625.00 224.79	2.64%
US Treasury Note 2.625% Dtd 06/30/2018 Due 06/30/2023	250,000.000	247,305.00 253,113.05	6,562.00 1,658.45	2.65%
US Treasury Note 2.50% Dtd 01/31/2019 Due 01/31/2024	200,000.000	195,298.00 199,508.82	5,000.00 842.39	2.56%
US Treasury Note 2.375% Dtd 02/28/2019 Due 02/29/2024	150,000.000	146,062.50 151,720.68	3,562.00 305.07	2.44%
Waco Tex Indpt Sch Dist Taxable Unltd Tax Ref Bd Taxable Zero Cpn Dtd 01/01/2021 Due 08/15/2024 Non-Callable	150,000.000	137,455.50 148,469.34	0.00	0.00%
Waco Tex Indpt Sch Dist Taxable Unltd Tax Ref Bd Taxable Zero Cpn Dtd 01/01/2021 Due 08/15/2025 Non-Callable	100,000.000	86,928.00 97,944.05	0.00	0.00%



**WBSD - EMERGENCY CAPITAL RESERVE**

Account Number:  
Statement Period:

07/01/22 - 09/30/22

**Asset Position As of 09/30/22**

Asset Description	Units	Market Value Cost	Est. Annual Income Accruals	Current Yield
<b>Total Fixed Income</b>		\$ 4,531,909.93 \$ 4,745,695.21	90,977.00 23,931.95	2.01%
<b>Cash</b>				
Principal Cash		0.00 0.00	0.00	0.00%
Income Cash		0.00 0.00	0.00	0.00%
<b>Total Cash</b>		\$ 0.00 \$ 0.00	0.00 0.00	0.00%
<b>Total Market Value</b>		\$ 4,803,425.99 \$ 5,017,225.43	93,789.00 25,019.47	1.95%
<b>Total Market Value Plus Accruals</b>		\$ 4,828,445.46		

**Income Activity**

	Date	Income Cash	Principal Cash
<b>Interest Income</b>			
Bank of The West Advantage Acct			
Int To 06/30/22	07/01/22		51.90
Int To 07/31/22	08/01/22		162.13
Int To 08/31/22	09/01/22		271.50
Anz National Intl LTD Fr			
3.40% Dtd 03/19/2019 Due 03/19/2024			
Non-Callable			
Int To 09/19/22 on 50,000	09/19/22		850.00
American Express Co Sr Gbl			
2.50% Dtd 07/30/2019 Due 07/30/2024			
Callable			
Int To 07/30/22 on 100,000	08/01/22		1,250.00
Apple Inc Sr Gbl			
0.70% Dtd 02/08/2021 Due 02/08/2026			
Callable			
Int To 08/08/22 on 50,000	08/08/22		175.00
Blackrock Inc Sr Nt			
3.50% Dtd 03/18/2014 Due 03/18/2024			
Callable			
Int To 09/18/22 on 100,000	09/19/22		1,750.00



**WBSD - EMERGENCY CAPITAL RESERVE**

Account Number:  
 Statement Period:

07/01/22 - 09/30/22

Income Activity			
	Date	Income Cash	Principal Cash
Comcast Corp New Sr Nt 3.375% Dtd 05/27/2015 Due 08/15/2025 Callable Int To 08/15/22 on 55,000	08/15/22		928.12
Deere John Capital Corp Fr 3.45% Dtd 03/13/2018 Due 03/13/2025 Non-Callable Int To 09/13/22 on 40,000	09/13/22		690.00
Disney Walt Co Sr Gbl Nt 1.65% Dtd 09/06/2019 Due 09/01/2022 Callable Int To 09/01/22 on 45,000	09/01/22		371.25
Exxon Mobil Corp Sr Gbl Nt 1.902% Dtd 08/16/2019 Due 08/16/2022 Callable Int To 08/16/22 on 45,000	08/16/22		427.95
Federal Farm Cr Bks Cons Systemwide Bds 1.90% Dtd 08/03/2017 Due 08/03/2022 Non-Callable Int To 08/03/22 on 80,000	08/03/22		760.00
JPMorgan Chase & Co Sr Nt 3.25% Dtd 09/24/2012 Due 09/23/2022 Non-Callable Int To 09/23/22 on 80,000	09/23/22		1,300.00
Longview Tex Indpt Sch Dist Ultd Tax Ref Bds 5.00% Dtd 04/15/2016 Due 02/15/2023 Non-Callable Int To 08/15/22 on 55,000	08/15/22		1,375.00
Maryland St GO Bds 2014 S 5.00% Dtd 08/05/2014 Due 08/01/2023 Prerefunded 08/01/2022 @ 100.000 Callable Int To 08/01/22 on 60,000	08/01/22		1,500.00
New York St Dorm Auth Revs Non Univ Rev Bds 2019b Taxable 2.839% Dtd 02/21/2019 Due 07/01/2022 Callable Int To 07/01/22 on 150,000	07/01/22		2,129.25
Oklahoma St Capitol Impt Auth Bds 2019 C 4.00% Dtd 09/10/2019 Due 01/01/2023 Non-Callable Int To 07/01/22 on 50,000	07/01/22		1,000.00



**WBSD - EMERGENCY CAPITAL RESERVE**

Account Number:  
 Statement Period:

07/01/22 - 09/30/22

Income Activity			
	Date	Income Cash	Principal Cash
San Diego Tex Indpt Sch Dist Unltd Tax Ref Bds 3.00% Dtd 05/15/2020 Due 08/15/2022 Non-Callable Int To 08/15/22 on 100,000	08/15/22		1,500.00
Small Business Admin Gtd Ln Pool Ctfs 4.34% Dtd 03/17/2004 Due 03/01/2024 Callable Int To 08/16/22 on 2399.46	09/01/22		52.07
Synchrony Financial Sr Gbl Nt 4.25% Dtd 08/11/2014 Due 08/15/2024 Callable Int To 08/15/22 on 55,000	08/15/22		1,168.75
Tamalpais Calif Un High Sch Di GO Ref Bds 5.00% Dtd 11/25/2014 Due 08/01/2023 Non-Callable Int To 08/01/22 on 60,000	08/01/22		1,500.00
Toyota Motor Credit Corp Fr 2.90% Dtd 04/01/2020 Due 03/30/2023 Non-Callable Int To 09/30/22 on 90,000	09/30/22		1,305.00
US Treasury Note 0.375% Dtd 08/15/2021 Due 08/15/2024 Int To 08/15/22 on 100,000	08/15/22		187.50
US Treasury Note 0.875% Dtd 01/31/2022 Due 01/31/2024 Int 01/31/22 To 07/31/22 on 100000	08/01/22		437.50
US Treasury Note 2.25% Dtd 03/31/2022 Due 03/31/2024 Int 03/31/22 To 09/30/22 on 50000	09/30/22		562.50
US Treasury Note 1.625% Dtd 02/15/2016 Due 02/15/2026 Int To 08/15/22 on 200,000	08/15/22		1,625.00
US Treasury Note 2.625% Dtd 02/28/2018 Due 02/28/2023 Int To 08/31/22 on 100,000	08/31/22		1,312.50
US Treasury Note 2.50% Dtd 01/31/2019 Due 01/31/2024 Int To 07/31/22 on 200,000	08/01/22		2,500.00



**WBSD - EMERGENCY CAPITAL RESERVE**

Account Number:  
 Statement Period:

07/01/22 - 09/30/22

Income Activity			
	Date	Income Cash	Principal Cash
US Treasury Note 2.375% Dtd 02/28/2019 Due 02/29/2024 Int To 08/31/22 on 150,000	08/31/22		1,781.25
<b>Total Interest Income</b>		<b>\$ 0.00</b>	<b>\$ 28,924.17</b>
<b>Purchased Income</b>			
US Treasury Note 0.125% Dtd 09/15/2020 Due 09/15/2023 Accrued Int To 09/23/22 Paid on Purchase of 200,000	09/23/22		-5.53
US Treasury Note 0.125% Dtd 12/15/2020 Due 12/15/2023 Accrued Int To 08/11/22 Paid on Purchase of 60,000	08/11/22		-11.68
US Treasury Note 0.50% Dtd 11/30/2021 Due 11/30/2023 Accrued Int To 07/11/22 Paid on Purchase of 50,000	07/11/22		-28.01
US Treasury Note 1.00% Dtd 12/15/2021 Due 12/15/2024 Accrued Int To 08/11/22 Paid on Purchase of 120,000	08/11/22		-186.89
US Treasury Note 0.875% Dtd 01/31/2022 Due 01/31/2024 Accrued Int To 07/11/22 Paid on Purchase of 100,000	07/11/22		-389.15
US Treasury Note 0.875% Dtd 01/31/2022 Due 01/31/2024			
US Treasury Note 2.00% Dtd 06/30/2017 Due 06/30/2024 Accrued Int To 07/11/22 Paid on Purchase of 100,000	07/11/22		-59.78
<b>Total Purchased Income</b>		<b>\$ 0.00</b>	<b>\$ -681.04</b>
<b>Total Income</b>		<b>\$ 0.00</b>	<b>\$ 28,243.13</b>





**WBSD - EMERGENCY CAPITAL RESERVE**

Account Number:  
 Statement Period:

07/01/22 - 09/30/22

**Disbursement Activity**

	Date	Income Cash	Principal Cash
<b>Fees/Expenses</b>			
Monthly Fee To 06/30/22	07/15/22		-712.57
Monthly Fee To 07/31/22	08/15/22		-697.65
Monthly Fee To 08/31/22	09/15/22		-695.86
<b>Total Fees/Expenses</b>		<b>\$ 0.00</b>	<b>\$ -2,106.08</b>
<b>Total Disbursements</b>		<b>\$ 0.00</b>	<b>\$ -2,106.08</b>

**Purchase Activity**

	Date	Income Cash	Principal Cash
Bank of The West Advantage Acct Purchases (11) 07/01/22 To 09/30/22	09/30/22		-508,530.27
US Treasury Note 0.125% Dtd 09/15/2020 Due 09/15/2023 Purchased 200000 09/22/22 From First Tennessee Bank NA Bond Di @ 96.207031	09/23/22		-192,414.06
US Treasury Note 0.125% Dtd 12/15/2020 Due 12/15/2023 Purchased 60000 08/10/22 From Wells Fargo Securities, LLC @ 95.933593	08/11/22		-57,560.16
US Treasury Note 0.50% Dtd 11/30/2021 Due 11/30/2023 Purchased 50000 07/08/22 From Wells Fargo Securities, LLC @ 96.488281	07/11/22		-48,244.14
US Treasury Note 1.00% Dtd 12/15/2021 Due 12/15/2024 Purchased 120000 08/10/22 From Morgan Stanley & Co @ 95.085938	08/11/22		-114,103.13
US Treasury Note 0.875% Dtd 01/31/2022 Due 01/31/2024 Purchased 100000 07/08/22 From Wells Fargo Securities, LLC @ 96.597656	07/11/22		-96,597.66
US Treasury Note 0.875% Dtd 01/31/2022 Due 01/31/2024			



**WBSD - EMERGENCY CAPITAL RESERVE**

Account Number:  
 Statement Period:

07/01/22 - 09/30/22

Purchase Activity			
	Date	Income Cash	Principal Cash
US Treasury Note 2.00% Dtd 06/30/2017 Due 06/30/2024 Purchased 100000 07/08/22 From Wells Fargo Securities, LLC @ 97.90625	07/11/22		-97,906.25
<b>Total Purchases</b>		<b>\$ 0.00</b>	<b>\$ -1,115,355.67</b>

Sale Activity			
	Date	Proceeds	Realized Gain/Loss
Bank of The West Advantage Acct Sales (7) 07/01/22 To 09/30/22	09/30/22	528,312.52	
Disney Walt Co Sr Gbl Nt 1.65% Dtd 09/06/2019 Due 09/01/2022 Callable Recd Proceeds on Maturity of 45,000 Par Value	09/01/22	45,000.00	
Exxon Mobil Corp Sr Gbl Nt 1.902% Dtd 08/16/2019 Due 08/16/2022 Callable Recd Proceeds on Maturity of 45,000 Par Value	08/16/22	45,000.00	
Federal Farm Cr Bks Cons Systemwide Bds 1.90% Dtd 08/03/2017 Due 08/03/2022 Non-Callable Recd Proceeds on Maturity of 80,000 Par Value	08/03/22	80,000.00	
JPMorgan Chase & Co Sr Nt 3.25% Dtd 09/24/2012 Due 09/23/2022 Non-Callable Recd Proceeds on Maturity of 80,000 Par Value	09/23/22	80,000.00	
Maryland St GO Bds 2014 S 5.00% Dtd 08/05/2014 Due 08/01/2023 Prerefunded 08/01/2022 @ 100.000 Callable Recd Proceeds on Pre-Refund of 60,000 Par Value	08/01/22	60,000.00	
New York St Dorm Auth Revs Non Univ Rev Bds 2019b Taxable 2.839% Dtd 02/21/2019 Due 07/01/2022 Callable Recd Proceeds on Maturity of 150,000 Par Value	07/01/22	150,000.00	



**WBSD - EMERGENCY CAPITAL RESERVE**

Account Number:  
 Statement Period:

07/01/22 - 09/30/22

Sale Activity			
	Date	Proceeds	Realized Gain/Loss
San Diego Tex Indpt Sch Dist Unltd Tax Ref Bds 3.00% Dtd 05/15/2020 Due 08/15/2022 Non-Callable Recd Proceeds on Maturity of 100,000 Par Value	08/15/22	100,000.00	
Small Business Admin Gtd Ln Pool Ctfs 4.34% Dtd 03/17/2004 Due 03/01/2024 Callable Prin Pmt For 08/16/22	09/01/22	906.10	-522.32
<b>Total Sales</b>		<b>\$ 1,089,218.62</b>	<b>\$ -522.32</b>

Non-Cash Activity		
	Date	Cost
Anz National Intl LTD Fr 3.40% Dtd 03/19/2019 Due 03/19/2024 Non-Callable Amortization of Premium	09/19/22	-640.50
American Express Co Sr Gbl 2.50% Dtd 07/30/2019 Due 07/30/2024 Callable Amortization of Premium	07/29/22	-697.00
Beverly Hills Calif Uni Sch Di GO Bds Zero Cpn Dtd 02/10/2009 Due 08/01/2023 Non-Callable		
Accretion of Discount	07/29/22	15.75
Accretion of Discount	08/31/22	15.75
Accretion of Discount	09/30/22	15.75
Blackrock Inc Sr Nt 3.50% Dtd 03/18/2014 Due 03/18/2024 Callable Amortization of Premium	09/16/22	-741.00
Amortization of Premium	09/16/22	-1,072.00
Comcast Corp New Sr Nt 3.375% Dtd 05/27/2015 Due 08/15/2025 Callable Amortization of Premium	08/15/22	-675.40
Deere John Capital Corp Fr 3.45% Dtd 03/13/2018 Due 03/13/2025 Non-Callable Amortization of Premium	09/13/22	-554.00



**WBSD - EMERGENCY CAPITAL RESERVE**

Account Number:  
 Statement Period:

07/01/22 - 09/30/22

Non-Cash Activity		
	Date	Cost
Disney Walt Co Sr Gbl Nt 1.65% Dtd 09/06/2019 Due 09/01/2022 Callable Amortization of Premium	09/01/22	-212.85
Exxon Mobil Corp Sr Gbl Nt 1.902% Dtd 08/16/2019 Due 08/16/2022 Callable Amortization of Premium	08/16/22	-327.60
Federal Farm Cr Bks Cons Systemwide Bds 1.90% Dtd 08/03/2017 Due 08/03/2022 Non-Callable Amortization of Premium	08/03/22	-21.60
JPMorgan Chase & Co Sr Nt 3.25% Dtd 09/24/2012 Due 09/23/2022 Non-Callable Amortization of Premium	09/23/22	-526.95
	09/23/22	-410.90
Longview Tex Indpt Sch Dist Ultd Tax Ref Bds 5.00% Dtd 04/15/2016 Due 02/15/2023 Non-Callable Amortization of Premium	08/15/22	-1,285.90
Maryland St GO Bds 2014 S 5.00% Dtd 08/05/2014 Due 08/01/2023 Prerefunded 08/01/2022 @ 100.000 Callable Amortization of Premium	08/01/22	-1,388.40
Mountain View Los Altos Calif GO Bds 2010a Zero Cpn Dtd 09/09/2010 Due 08/01/2023 Non-Callable Accretion of Discount	07/29/22	14.50
	08/31/22	14.50
	09/30/22	14.50
New York St Dorm Auth Revs Non Univ Rev Bds 2019b Taxable 2.839% Dtd 02/21/2019 Due 07/01/2022 Callable Amortization of Premium	07/01/22	-559.00
	07/01/22	-279.50
Oklahoma St Capitol Impt Auth Bds 2019 C 4.00% Dtd 09/10/2019 Due 01/01/2023 Non-Callable Amortization of Premium	07/01/22	-883.50



**WBSD - EMERGENCY CAPITAL RESERVE**

Account Number:  
 Statement Period:

07/01/22 - 09/30/22

Non-Cash Activity		
	Date	Cost
San Diego Tex Indpt Sch Dist Unltd Tax Ref Bds 3.00% Dtd 05/15/2020 Due 08/15/2022 Non-Callable Amortization of Premium	08/15/22	-894.00
Synchrony Financial Sr Gbl Nt 4.25% Dtd 08/11/2014 Due 08/15/2024 Callable Amortization of Premium	08/15/22	-677.05
Tamalpais Calif Un High Sch Di GO Ref Bds 5.00% Dtd 11/25/2014 Due 08/01/2023 Non-Callable Amortization of Premium	08/01/22	-1,033.65
	08/01/22	-346.95
Toyota Motor Credit Corp Fr 2.90% Dtd 04/01/2020 Due 03/30/2023 Non-Callable Amortization of Premium	09/30/22	-479.50
Amortization of Premium	09/30/22	-384.40
US Treasury Note 0.375% Dtd 08/15/2021 Due 08/15/2024 Accretion of Discount	08/15/22	490.68
US Treasury Note 0.875% Dtd 01/31/2022 Due 01/31/2024 Accretion of Discount	07/29/22	115.64
US Treasury Note 2.25% Dtd 03/31/2022 Due 03/31/2024 Accretion of Discount	09/30/22	60.97
US Treasury Note 1.625% Dtd 02/15/2016 Due 02/15/2026 Accretion of Discount	08/15/22	738.95
US Treasury Note 2.625% Dtd 02/28/2018 Due 02/28/2023 Amortization of Premium	08/31/22	-711.04
US Treasury Note 2.50% Dtd 01/31/2019 Due 01/31/2024 Accretion of Discount	07/29/22	79.13
US Treasury Note 2.375% Dtd 02/28/2019 Due 02/29/2024 Amortization of Premium	08/31/22	-564.49



**WBSD - EMERGENCY CAPITAL RESERVE**

Account Number:  
 Statement Period:

07/01/22 - 09/30/22

Non-Cash Activity		
	Date	Cost
Waco Tex Indpt Sch Dist Taxable Unltd Tax Ref Bd Taxable Zero Cpn Dtd 01/01/2021 Due 08/15/2024 Non-Callable		
Accretion of Discount	07/29/22	68.02
Accretion of Discount	08/31/22	68.02
Accretion of Discount	09/30/22	68.02
Waco Tex Indpt Sch Dist Taxable Unltd Tax Ref Bd Taxable Zero Cpn Dtd 01/01/2021 Due 08/15/2025 Non-Callable		
Accretion of Discount	07/29/22	59.58
Accretion of Discount	08/31/22	59.58
Accretion of Discount	09/30/22	59.58
<b>Total Non-Cash Transactions</b>		<b>\$ -13,408.26</b>

SECURITY PRICES CONTAINED IN THIS STATEMENT ARE OBTAINED FROM THE MOST RELIABLE SOURCES AVAILABLE BUT ARE NOT GUARANTEED BY BANK OF THE WEST. QUOTED PRICES MAY NOT EQUAL ACTUAL PRICES BECAUSE OF SECURITY SIZE, MARKET PRICE, TERM AND DEMAND.



**BANK OF THE WEST**  
**BNP PARIBAS**  
**WEALTH MANAGEMENT**

### **Electronic Funds Transfers**

#### **Preauthorized Transfers:**

You may request an electronic fund transfer (EFT), such as an ACH transfer from or deposit to your account, by contacting your account Administrator. You may also preauthorize periodic EFTs by contacting your account Administrator. If you would like to know whether a preauthorized EFT has occurred, please contact your account Administrator at the phone number listed on the first page of your statement. TTY 1-866-936-2689, Monday - Friday, 8 a.m. - 4:30 p.m. Central Time.

#### **Error Resolution Notice:**

If you think a statement or receipt is wrong or if you need more information about an EFT listed on a statement or receipt, telephone your account Administrator at the phone number listed on the first page of your statement, TTY 1-866-936-2689, Monday - Friday, 8 a.m. - 4:30 p.m. Central Time, write to us at Bank of the West, GIFS Operations, 12000 North Washington Street, Suite, 300, Thornton, CO 80241 or e-mail us at [WMGGIFSOperations@bankofthewest.com](mailto:WMGGIFSOperations@bankofthewest.com) as soon as possible. We must hear from you no later than 60 days after we sent the FIRST statement on which the problem or error appeared.

1. Tell us your name and account number (if any).
2. Tell us the dollar amount of the suspected error.
3. Describe the error or the transfer you are unsure about, and explain as clearly as you can why you believe it is an error or why you need more information.

If you contact us verbally, we may require that you send us your complaint or question in writing within 10 business days. We will investigate your complaint and will correct any error promptly. If we take more than 10 business days to do this, we will credit your account for the amount you think is in error, so that you will have the use of the money during the time it takes us to complete our investigation.



**WBSD - RECYCLED WATER CASH FLOW**

Account Number:  
 Statement Period: 07/01/22 - 09/30/22

WEST BAY SANITARY DISTRICT  
 500 LAUREL STREET  
 MENLO PARK CA 94025

**Fiduciary**  
 Chuen Ying Lee  
 (408) 645-3234  
**Portfolio**  
 Michael D. Smith  
 (408) 490-2079

**Asset Allocation**

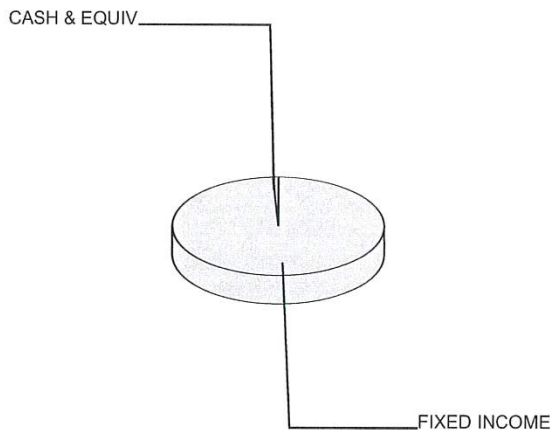

**Asset Valuation**

Description	Market Value	% of Account
Cash & Equiv	37,124.41	0.7%
Fixed Income	5,498,092.35	99.3%
<b>Total Portfolio</b>	<b>\$ 5,535,216.76</b>	<b>100.0%</b>
Accrued Income	21,559.64	
<b>Total Valuation</b>	<b>\$ 5,556,776.40</b>	

**Market Reconciliation**

	Current Period	Year To Date
<b>Beginning Market Value</b>	<b>\$ 5,623,527.18</b>	<b>\$ 5,623,527.18</b>
Income		
Interest.....	32,114.44	32,114.44
Purchased Income.....	-15.85	-15.85
Disbursements.....	-2,427.31	-2,427.31
Realized Gains/(Losses).....	0.00	0.00
Change In Accrued Income.....	-3,709.69	-3,709.69
Change In Market Appreciation/(Depreciation).....	-97,085.39	-97,085.39
Non-Cash Asset Changes.....	4,373.02	4,373.02
<b>Ending Market Value</b>	<b>\$ 5,556,776.40</b>	<b>\$ 5,556,776.40</b>





**WBSD - RECYCLED WATER CASH FLOW**

Account Number:  
 Statement Period:

07/01/22 - 09/30/22

**Asset Position As of 09/30/22**

Asset Description	Units	Market Value Cost	Est. Annual Income Accruals	Current Yield
<b>Cash Equivalents</b>				
Bank of The West Advantage Acct	37,124.410	37,124.41 37,124.41	853.00 29.88	2.30%
<b>Total Cash Equivalents</b>		<b>\$ 37,124.41</b> <b>\$ 37,124.41</b>	<b>853.00</b> <b>29.88</b>	<b>2.30%</b>
<b>Fixed Income</b>				
Anz National Intl LTD Fr 3.40% Dtd 03/19/2019 Due 03/19/2024 Non-Callable	70,000.000	68,551.00 72,716.60	2,380.00 79.33	3.47%
BB&T Corp Sr Medium Term Nts Fr 3.70% Dtd 06/05/2018 Due 06/05/2025 Callable	15,000.000	14,479.95 16,266.30	555.00 178.83	3.83%
Blackrock Inc Sr Nt 3.50% Dtd 03/18/2014 Due 03/18/2024 Callable	70,000.000	68,994.10 73,131.70	2,450.00 88.47	3.55%
Comcast Corp New Sr Nt 3.375% Dtd 05/27/2015 Due 08/15/2025 Callable	30,000.000	28,796.70 32,248.20	1,012.00 129.37	3.52%
Federal Farm Cr Bks Cons Systemwide Bds 0.71% Dtd 04/21/2021 Due 04/21/2025 Callable	20,000.000	18,176.20 20,000.00	142.00 63.11	0.78%
Kla Tencor Corp Sr Gbl Nt 4.65% Dtd 11/06/2014 Due 11/01/2024 Callable	20,000.000	19,932.00 21,729.00	930.00 387.49	4.67%
New York N Y GO Bds Subser Taxable 4.669% Dtd 10/15/2009 Due 10/01/2022 Callable	35,000.000	35,000.00 35,462.35	1,634.00 817.07	4.67%
New York N Y GO Bds 2010 D Taxable 5.199% Dtd 12/17/2009 Due 12/01/2022 Callable	60,000.000	60,148.80 61,025.40	3,119.00 1,039.80	5.19%
Synchrony Financial Sr Gbl Nt 4.25% Dtd 08/11/2014 Due 08/15/2024 Callable	40,000.000	39,002.00 42,013.20	1,700.00 217.22	4.36%
US Treasury Note 0.125% Dtd 12/15/2020 Due 12/15/2023	20,000.000	19,034.40 19,186.72	25.00 7.37	0.13%



**WBSD - RECYCLED WATER CASH FLOW**

Account Number:  
 Statement Period:

07/01/22 - 09/30/22

**Asset Position As of 09/30/22**

Asset Description	Units	Market Value Cost	Est. Annual Income Accruals	Current Yield
US Treasury Note 0.75% Dtd 03/31/2021 Due 03/31/2026	20,000.000	17,763.40 19,896.88	150.00 0.41	0.84%
US Treasury Note 0.375% Dtd 08/15/2021 Due 08/15/2024	120,000.000	111,646.80 112,934.13	450.00 57.47	0.40%
US Treasury Note 0.875% Dtd 01/31/2022 Due 01/31/2024	1,600,000.000	1,528,688.00 1,561,181.92	14,000.00 2,358.69	0.92%
US Treasury Note 2.25% Dtd 03/31/2022 Due 03/31/2024	1,800,000.000	1,746,288.00 1,790,593.32	40,500.00 111.26	2.32%
US Treasury Note 1.625% Dtd 10/31/2016 Due 10/31/2023	50,000.000	48,601.50 50,073.13	812.00 340.01	1.67%
US Treasury Note 2.50% Dtd 05/15/2014 Due 05/15/2024	1,600,000.000	1,554,512.00 1,596,562.50	40,000.00 15,108.69	2.57%
US Treasury Note 2.00% Dtd 06/30/2017 Due 06/30/2024	20,000.000	19,236.00 19,581.25	400.00 101.09	2.08%
US Treasury Note 2.625% Dtd 02/28/2018 Due 02/28/2023	50,000.000	49,780.50 50,357.63	1,312.00 112.39	2.64%
US Treasury Note 2.625% Dtd 06/30/2018 Due 06/30/2023	50,000.000	49,461.00 50,622.61	1,312.00 331.69	2.65%
<b>Total Fixed Income</b>		<b>\$ 5,498,092.35</b> <b>\$ 5,645,582.84</b>	<b>112,883.00</b> <b>21,529.76</b>	<b>2.05%</b>
<b>Cash</b>				
Principal Cash		0.00 0.00	0.00	0.00%
Income Cash		0.00 0.00	0.00	0.00%
<b>Total Cash</b>		<b>\$ 0.00</b> <b>\$ 0.00</b>	<b>0.00</b> <b>0.00</b>	<b>0.00%</b>
<b>Total Market Value</b>		<b>\$ 5,535,216.76</b> <b>\$ 5,682,707.25</b>	<b>113,736.00</b> <b>21,559.64</b>	<b>2.05%</b>
<b>Total Market Value Plus Accruals</b>		<b>\$ 5,556,776.40</b>		



**WBSD - RECYCLED WATER CASH FLOW**

Account Number:  
 Statement Period: 07/01/22 - 09/30/22

Income Activity			
	Date	Income Cash	Principal Cash
<b>Interest Income</b>			
Bank of The West Advantage Acct			
Int To 06/30/22	07/01/22		63.48
Int To 07/31/22	08/01/22		39.99
Int To 08/31/22	09/01/22		33.47
Anz National Intl LTD Fr			
3.40% Dtd 03/19/2019 Due 03/19/2024			
Non-Callable			
Int To 09/19/22 on 70,000	09/19/22		1,190.00
Blackrock Inc Sr Nt			
3.50% Dtd 03/18/2014 Due 03/18/2024			
Callable			
Int To 09/18/22 on 70,000	09/19/22		1,225.00
Comcast Corp New Sr Nt			
3.375% Dtd 05/27/2015 Due 08/15/2025			
Callable			
Int To 08/15/22 on 30,000	08/15/22		506.25
Synchrony Financial Sr Gbl Nt			
4.25% Dtd 08/11/2014 Due 08/15/2024			
Callable			
Int To 08/15/22 on 40,000	08/15/22		850.00
US Treasury Note			
0.75% Dtd 03/31/2021 Due 03/31/2026			
Int To 09/30/22 on 20,000	09/30/22		75.00
US Treasury Note			
0.375% Dtd 08/15/2021 Due 08/15/2024			
Int To 08/15/22 on 120,000	08/15/22		225.00
US Treasury Note			
0.875% Dtd 01/31/2022 Due 01/31/2024			
Int 01/31/22 To 07/31/22 on 1600000	08/01/22		7,000.00
US Treasury Note			
2.25% Dtd 03/31/2022 Due 03/31/2024			
Int 03/31/22 To 09/30/22 on 1800000	09/30/22		20,250.00
US Treasury Note			
2.625% Dtd 02/28/2018 Due 02/28/2023			
Int To 08/31/22 on 50,000	08/31/22		656.25
<b>Total Interest Income</b>		<b>\$ 0.00</b>	<b>\$ 32,114.44</b>



**WBSD - RECYCLED WATER CASH FLOW**

Account Number:  
 Statement Period: 07/01/22 - 09/30/22

Income Activity			
	Date	Income Cash	Principal Cash
<b>Purchased Income</b>			
US Treasury Note 0.125% Dtd 12/15/2020 Due 12/15/2023 Accrued Int To 08/11/22 Paid on Purchase of 20,000	08/11/22		-3.89
US Treasury Note 2.00% Dtd 06/30/2017 Due 06/30/2024 Accrued Int To 07/11/22 Paid on Purchase of 20,000	07/11/22		-11.96
<b>Total Purchased Income</b>		<b>\$ 0.00</b>	<b>\$ -15.85</b>
<b>Total Income</b>		<b>\$ 0.00</b>	<b>\$ 32,098.59</b>

Disbursement Activity			
	Date	Income Cash	Principal Cash
<b>Fees/Expenses</b>			
Monthly Fee To 06/30/22	07/15/22		-822.53
Monthly Fee To 07/31/22	08/15/22		-804.19
Monthly Fee To 08/31/22	09/15/22		-800.59
<b>Total Fees/Expenses</b>		<b>\$ 0.00</b>	<b>\$ -2,427.31</b>
<b>Total Disbursements</b>		<b>\$ 0.00</b>	<b>\$ -2,427.31</b>

Purchase Activity			
	Date	Income Cash	Principal Cash
Bank of The West Advantage Acct Purchases (7) 07/01/22 To 09/30/22	09/30/22		-32,114.44
US Treasury Note 0.125% Dtd 12/15/2020 Due 12/15/2023 Purchased 20000 08/10/22 From Wells Fargo Securities, LLC @ 95.933593	08/11/22		-19,186.72



**WBSD - RECYCLED WATER CASH FLOW**

Account Number:  
 Statement Period: 07/01/22 - 09/30/22

Purchase Activity			
	Date	Income Cash	Principal Cash
US Treasury Note 2.00% Dtd 06/30/2017 Due 06/30/2024 Purchased 20000 07/08/22 From Wells Fargo Securities, LLC @ 97.90625	07/11/22		-19,581.25
<b>Total Purchases</b>		<b>\$ 0.00</b>	<b>\$ -70,882.41</b>

Sale Activity			
	Date	Proceeds	Realized Gain/Loss
Bank of The West Advantage Acct Sales (5) 07/01/22 To 09/30/22	09/30/22	41,211.13	
<b>Total Sales</b>		<b>\$ 41,211.13</b>	<b>\$ 0.00</b>

Non-Cash Activity		
	Date	Cost
Anz National Intl LTD Fr 3.40% Dtd 03/19/2019 Due 03/19/2024 Non-Callable Amortization of Premium	09/19/22	-256.20
Amortization of Premium	09/19/22	-642.00
Blackrock Inc Sr Nt 3.50% Dtd 03/18/2014 Due 03/18/2024 Callable Amortization of Premium	09/16/22	-296.40
Amortization of Premium	09/16/22	-742.50
Comcast Corp New Sr Nt 3.375% Dtd 05/27/2015 Due 08/15/2025 Callable Amortization of Premium	08/15/22	-369.30
Synchrony Financial Sr Gbl Nt 4.25% Dtd 08/11/2014 Due 08/15/2024 Callable Amortization of Premium	08/15/22	-493.20
US Treasury Note 0.375% Dtd 08/15/2021 Due 08/15/2024 Accretion of Discount	08/15/22	588.82



**WBSD - RECYCLED WATER CASH FLOW**

Account Number:  
Statement Period:

07/01/22 - 09/30/22

Non-Cash Activity		
	Date	Cost
US Treasury Note 0.875% Dtd 01/31/2022 Due 01/31/2024 Accretion of Discount	07/29/22	4,744.43
US Treasury Note 2.25% Dtd 03/31/2022 Due 03/31/2024 Accretion of Discount	09/30/22	2,194.89
US Treasury Note 2.625% Dtd 02/28/2018 Due 02/28/2023 Amortization of Premium	08/31/22	-355.52
<b>Total Non-Cash Transactions</b>		<b>\$ 4,373.02</b>

SECURITY PRICES CONTAINED IN THIS STATEMENT ARE OBTAINED FROM THE MOST RELIABLE SOURCES AVAILABLE BUT ARE NOT GUARANTEED BY BANK OF THE WEST. QUOTED PRICES MAY NOT EQUAL ACTUAL PRICES BECAUSE OF SECURITY SIZE, MARKET PRICE, TERM AND DEMAND.



### **Electronic Funds Transfers**

#### **Preauthorized Transfers:**

You may request an electronic fund transfer (EFT), such as an ACH transfer from or deposit to your account, by contacting your account Administrator. You may also preauthorize periodic EFTs by contacting your account Administrator. If you would like to know whether a preauthorized EFT has occurred, please contact your account Administrator at the phone number listed on the first page of your statement. TTY 1-866-936-2689, Monday - Friday, 8 a.m. - 4:30 p.m. Central Time.

#### **Error Resolution Notice:**

If you think a statement or receipt is wrong or if you need more information about an EFT listed on a statement or receipt, telephone your account Administrator at the phone number listed on the first page of your statement, TTY 1-866-936-2689, Monday - Friday, 8 a.m. - 4:30 p.m. Central Time, write to us at Bank of the West, GIFS Operations, 12000 North Washington Street, Suite, 300, Thornton, CO 80241 or e-mail us at [WMGGIFSOoperations@bankofthewest.com](mailto:WMGGIFSOoperations@bankofthewest.com) as soon as possible. We must hear from you no later than 60 days after we sent the FIRST statement on which the problem or error appeared.

1. Tell us your name and account number (if any).
2. Tell us the dollar amount of the suspected error.
3. Describe the error or the transfer you are unsure about, and explain as clearly as you can why you believe it is an error or why you need more information.

If you contact us verbally, we may require that you send us your complaint or question in writing within 10 business days. We will investigate your complaint and will correct any error promptly. If we take more than 10 business days to do this, we will credit your account for the amount you think is in error, so that you will have the use of the money during the time it takes us to complete our investigation.

THIS PAGE LEFT INTENTIONALLY BLANK





**WEST BAY SANITARY DISTRICT  
AGENDA ITEM 8**

**To: Board of Directors**

**From: Robert Scheidt, Assistant Operations Superintendent**

**Subject: Consider Approving Purchase of a 2022 Ford Mach E to replace Vehicle Unit No. 201 assigned to the General Manager**

---

Background

During the budget approval process the Board of Directors approved the replacement of vehicle unit number 201 assigned to the General Manager. At the time the Board of Directors approved leasing a Ford Mach E (electric vehicle) at a rate of \$735.00 per month through the General Fund, Other Operational Expenses. Staff reserved a Ford Mach E in January of 2022 with a \$100.00 deposit. The retail price for the 2022 Ford Mach E is \$55,706.16.

Analysis

The estimate received from Ford Credit Municipal Finance's leasing branch was \$1,363.91 per month based on a 7.99% interest charged to the purchase price over a four year period. At the end of the four year term the District could purchase the vehicle for \$1.00.

Based on the interest rate charged to the purchase price the District would pay over \$9,000.00 in interest over the four year term. The total purchase price of the replacement vehicle is \$55,706.16 including tax. The District's Vehicle Replacement Reserve has a balance of \$1.2 million.

Fiscal Impact

The fiscal impact is \$55,706.16, minus the \$100.00, deposit to the Vehicle and Equipment Replacement Reserve.

Recommendation

The Assistant Operations Superintendent recommends the Board consider approving the purchase of a 2022 Ford Mach E to replace Vehicle Unit No. 201 and authorize the General Manager to used funds from the Vehicle & Equipment Replacement Reserve.

Attachments: Ford Credit Financing and Towne Ford Quotes



1 American Road, MD 7500  
Dearborn, Michigan 48126  
1-800-241-4199, press 1

## Financing Quote # 102448

October 13, 2022

Municipality: West Bay Sanitary District  
Dealer: Towne Ford

Ford Credit Municipal Finance is pleased to provide the following quote for your consideration.  
Expiration Date: 12/12/2022

### VEHICLE INFORMATION

Description	Unit Price
2022 Mach E	\$55,706.16

### COST INFORMATION

Total Asset Cost	Underwriting Fee	Amount Financed
\$55,706.16	\$545.00	\$56,251.16

### FINANCING OPTIONS

Number of Payments	Payment Timing	Rate	Payment Amount
36	Monthly	7.99%	\$1,750.79
48	Monthly	7.99%	\$1,363.91

This quote was prepared assuming the lease qualifies for Federal Income Tax Status for Ford Credit Company LLC under Section 103 of the IRS Code and is not a commitment by Ford Credit Municipal Finance. Financing is subject to credit review.

Thank you for the opportunity to provide this quote. If you have any questions, need additional options, or would like to proceed with the application process, please contact by using the information below.

Sincerely,

*Justin Misiara*

Justin Misiara  
Marketing Coordinator  
jmisiara@ford.com  
1-800-241-4199, press 1

Ford Motor Credit Company ("FMCC") is providing the information contained in this document for discussion purposes only in connection with a proposed arm's length commercial leasing transaction between you and FMCC. FMCC is acting for its own interest and has financial and other interests that differ from yours. FMCC is not acting as a municipal advisor or financial advisor to you, and has no fiduciary duty to you. The information provided in this document is not intended to be and should not be construed as "advice" within the meaning of Section 15B of the Securities Exchange Act of 1934 and the municipal advisor rules of the SEC. FMCC is not recommending that you take an action and you should discuss any actions with your own advisors as you deem appropriate.

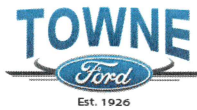

## Towne Ford Commercial and Fleet Sales

643 Bair Island Road, Suite 300, Redwood City, CA 94063  
 www.towneford.com  
 650-366-5749

BUYER	CO-BUYER	
WEST BAY SANITARY DISTRICT 500 LAUREL STREET MENLO PARK, CA 94025 <b>Cell #:</b> (650) 321-0384 <b>Email:</b> CNEVOLI@WESTBAYSANITARY.ORG		<b>Deal #:</b> 97695 <b>Deal Type:</b> Retail <b>Deal Date:</b> 10/17/2022 <b>Print Time:</b> 02:29pm
		<b>Salesperson:</b> LLOYD A PRATT
VEHICLE		
<b>New</b> <input checked="" type="checkbox"/> <b>Used</b> <input type="checkbox"/> <b>Demo</b> <input type="checkbox"/>	<b>Stock #:</b> NMA50339	<b>Description:</b> 2022 FORD TRUCK MUSTANG MACH E <b>VIN:</b> 3FMTK3RM3NMA50339 <b>Mileage:</b> 7
TRADE		
AFTERMARKETS		
		<b>MSRP:</b> \$ 50,910.00 <b>Discount:</b> \$ 100.00 <b>Sale Price:</b> \$ <b>50,810.00</b> <b>Total Financed Aftermarkets:</b> \$ 0.00 <b>Total Trade Allowance:</b> \$ 0.00 <b>Trade Difference:</b> \$ <b>50,810.00</b>  <b>Doc Fee:</b> \$ 85.00 <b>State &amp; Local Taxes:</b> \$ 4,771.41 <b>Total License and Fees:</b> \$ 39.75 <b>Total Cash Price:</b> \$ <b>55,706.16</b>  <b>Total Trade Payoff:</b> \$ 0.00 <b>Delivered Price:</b> \$ <b>55,706.16</b>
<b>Total Aftermarkets:</b>	<b>\$ 0.00</b>	
		<b>Cash Down Payment + Deposit:</b> \$ 100.00  <b>Sub Total:</b> \$ <b>55,606.16</b>  <b>Service Agreement:</b> \$ 0.00 <b>Maintenance Agreement:</b> \$ 0.00 <b>GAP Insurance:</b> \$ 0.00 <b>Credit Life, Accident &amp; Health:</b> \$ 0.00 <b>Other:</b> \$ 0.00 <b>Amount Financed:</b> \$ <b>55,606.16</b>
Rate:		
Amount Financed:	\$ 55,606.16	

THIS PAGE LEFT INTENTIONALLY BLANK



**WEST BAY SANITARY DISTRICT  
AGENDA ITEM 9**

**To: Board of Directors**

**From: Sergio Ramirez, General Manager**

**Subject: Discussion and Direction on the West Bay and Sharon Heights Recycled Water Facility**

---

A discussion will be held on the Sharon Heights Recycled Water Facility and other events related to the recycled water plant. The Board will have opportunity to provide direction to staff and legal counsel.

**Recycled Water Facility Production Data:**

<b>2020</b>	<b>Treated</b>	<b>Delivered</b>
August	8.8MG	8.2MG
September	8.2MG	5.1MG
October	7.4MG	4.5MG
November	5MG	1.4MG
December	4.7MG	.55MG
<b>2021</b>	<b>Treated</b>	<b>Delivered</b>
January	4.8MG	.23MG
February	4.4MG	.13MG
March	5.9MG	1.8MG
April	8.5MG	7.6MG
May	9.3.MG	8.2MG
June	9.8MG	8.7MG
July	9.5MG	9.1MG
August	9.4MG	9.0MG
September	9.1MG	6.9MG*
October	7.6MG	2.6MG**
November	5.2MG	0
December	4.7MG	0

<b>2022</b>	<b>Treated</b>	<b>Delivered</b>
January	4.4MG	97,000 gallons
February	4.4MG	1.5MG
March	6.6MG	3.5MG
April	7.6MG	3.8MG
May	9.2MG	7.4MG
June	9.8MG	8.7MG
July	9.6MG	8.1MG
August	9.2MG	8.1MG
September	8.6MG	6.7MG

\* Sharon Heights substantially tapered off their water usage for September which is the reason for the large discrepancy between treated and delivered.

\*\* Treatment was reduced in the second half of the month. Rain in late October and an irrigation equipment malfunctions caused water delivery to decrease.

*The following is a disclosure statement required for any document, written report or brochure prepared in whole or in part pursuant to the Finance Agreement with the State Water Resources Control Board for the West Bay Sanitary District Recycled Water Project - Sharon Heights: Funding for this project has been provided in full or in part through an agreement with the State Water Resources Control Board. California's Clean Water State Revolving Fund is capitalized through a variety of funding sources, including grants from the United States Environmental Protection Agency and state bond proceeds. The contents of this document do not necessarily reflect the views and policies of the foregoing, nor does mention of trade names or commercial products constitute endorsement or recommendation for use.*



**WEST BAY SANITARY DISTRICT  
AGENDA ITEM 10**

**To: Board of Directors**

**From: Sergio Ramirez, General Manager**

**Subject: Discussion and Direction on the Bayfront Recycled Water Project  
and Status Update**

---

A discussion will be held on the District's Bayfront Recycled Water Projects and other events related to the recycled water projects including financing, environmental review, design/build issues and grant applications.

The Board will have opportunity to provide direction to staff and general counsel.

THIS PAGE LEFT INTENTIONALLY BLANK





**WEST BAY SANITARY DISTRICT  
AGENDA ITEM 11**

**To: Board of Directors**

**From: Sergio Ramirez, General Manager**

**Subject: Report and Discussion on South Bayside Waste Management Authority (SBWMA)**

---

The District's representative to South Bayside Waste Management Authority (SBWMA), President Fran Dehn, will report on any pertinent items regarding SBWMA business.

THIS PAGE LEFT INTENTIONALLY BLANK



**WEST BAY SANITARY DISTRICT  
AGENDA ITEM 12**

**To: Board of Directors**

**From: Sergio Ramirez, General Manager**

**Subject: Report and Discussion on Silicon Valley Clean Water (SVCW)  
Plant**

---

The District's representative to Silicon Valley Clean Water (SVCW), Commissioner George Otte, will report on pertinent items regarding SVCW Operations, CIP and Finance.

THIS PAGE LEFT INTENTIONALLY BLANK