

LATERAL DISCONNECTION AT PROPERTY LINE FOR RE-USE

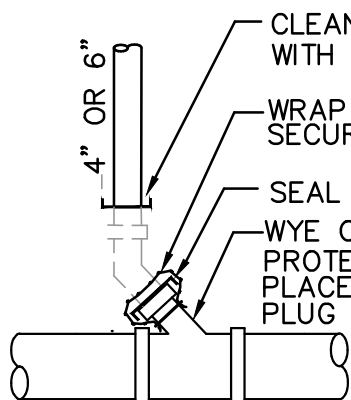

DETAIL 1

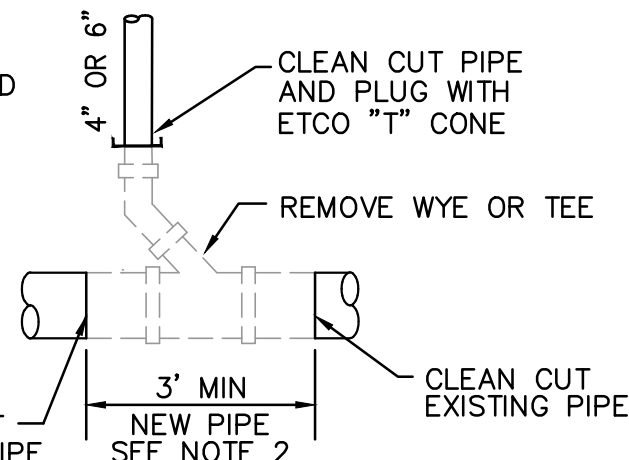

DETAIL 2

LATERAL DISCONNECTION AT MAIN SEWER (SEE NOTES 1&5)

**NOTES:**

1) THE CONTRACTOR SHALL EXCAVATE BY HAND EXPOSING THE WYE/TEE AT THE MAIN SEWER LINE FOR INSPECTION BY A WEST BAY REPRESENTATIVE. IF THE MAIN AND WYE/TEE ARE DEEMED IN GOOD CONDITION, PLUG WYE/TEE AS SHOWN IN DETAIL 1. IF THE MAIN IS IN GOOD CONDITION AND THE WYE/TEE IS IN POOR CONDITION, REMOVE TEE AND SECTION OF PIPE AS SHOWN IN DETAIL 2. IF BOTH MAIN AND WYE/TEE ARE IN POOR CONDITION, NOTIFY WBSD.

2) REPLACEMENT PIPE SHALL MATCH EXISTING SEWER MAIN PIPE. COUPLING SHALL BE SMITH-BLAIR 226 FULL CIRCLE STAINLESS STEEL CLAMP OR EQUAL FOR MAIN DIAMETER LESS THAN 15" AND ROCKWELL 228 FULL CIRCLE CLAMP OR EQUAL FOR MAIN 15" OR GREATER.

3) IF SEWER MAIN IS CONCRETE ENCASED OR CRADLED, ANY PORTION REMOVED BY CONTRACTOR SHALL BE REPLACED ENTIRELY TO THE SATISFACTION OF THE DISTRICT'S FIELD REPRESENTATIVE.

4) CONTRACTOR SHALL SUPPLY ADDRESS OF ABANDONED LATERAL AND DISTANCE AS MEASURED FROM THE DOWNSTREAM MANHOLE.

5) IT IS THE CONTRACTORS RESPONSIBILITY TO CONFIRM THAT NO OTHER PROPERTIES ARE CONNECTED TO THE LATERAL PRIOR TO DISCONNECTION.

**WEST BAY**

SANITARY DISTRICT

SANITARY SEWER  
LATERAL DISCONNECTIONS

APPROVED BY:

/s/ - PHIL SCOTT

DISTRICT MANAGER

06-24-15

DATE:

24